

# DATA SHEET

EEPW 电子产品世界  
.com.cn

## 74ALS157/74ALS158 Data selector/multiplexer

Product specification  
IC05 Data Handbook

1991 Feb 08

# Data selector/multiplexer

# 74ALS157/74ALS158

*74ALS157 Quad 2-input data selector/multiplexer, non-inverting*

*74ALS158 Quad 2-input data selector/multiplexer, inverting*

## DESCRIPTION

The 74ALS157 is a quad 2-input multiplexer which selects 4 bits of data from one of two sources under the control of a common select input (S). The enable input ( $\bar{E}$ ) is active when Low. When  $\bar{E}$  is High, all of the outputs (Yn) are forced Low regardless of all other input conditions.

Moving data from two registers to a common output bus is a typical use of the 74ALS157. The state of the select input determines the particular register from which data comes.

The device is the logic implementation of 4-pole, 2-position switch where the position of the switch is determined by the logic levels supplied to the select input. The 74ALS158 is similar but has inverting outputs ( $\bar{Y}n$ ).

TYPE	TYPICAL PROPAGATION DELAY	TYPICAL SUPPLY CURRENT (TOTAL)
74ALS157	6.0ns	6mA
74ALS158	6.0ns	6mA

## ORDERING INFORMATION

DESCRIPTION	ORDER CODE	DRAWING NUMBER
	COMMERCIAL RANGE $V_{CC} = 5V \pm 10\%$ , $T_{amb} = 0^{\circ}C$ to $+70^{\circ}C$	
16-pin plastic DIP	74ALS157N, 74ALS158N	SOT38-4
16-pin plastic SO	74ALS157D, 74ALS158D	SOT109-1

## INPUT AND OUTPUT LOADING AND FAN-OUT TABLE

PINS	DESCRIPTION	74ALS (U.L.) HIGH/LOW	LOAD VALUE HIGH/LOW
I <sub>na</sub> , I <sub>nb</sub> , I <sub>nc</sub> , I <sub>nd</sub>	Data inputs	1.0/1.0	20 $\mu$ A/0.1mA
S	Select input	1.0/1.0	20 $\mu$ A/0.1mA
$\bar{E}$	Enable input	1.0/1.0	20 $\mu$ A/0.1mA
Y <sub>a</sub> – Y <sub>d</sub> , $\bar{Y}_a$ – $\bar{Y}_d$	Data outputs	20/240	0.4mA/24mA

**NOTE:** One (1.0) ALS unit load is defined as: 20 $\mu$ A in the High state and 0.1mA in the Low state.

## PIN CONFIGURATION – 74ALS157

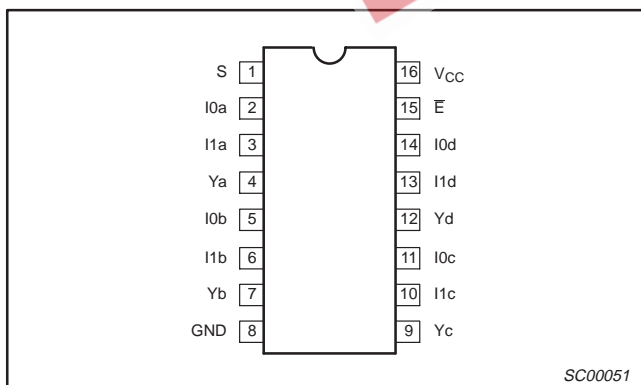

## PIN CONFIGURATION – 74ALS158

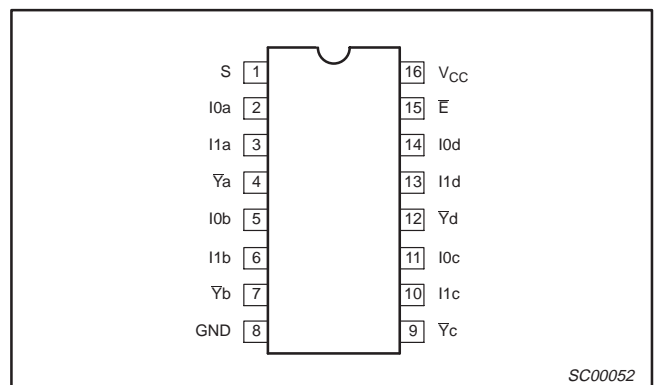

## LOGIC SYMBOL – 74ALS157

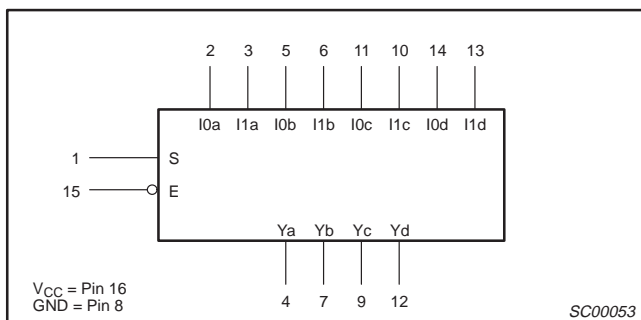

## LOGIC SYMBOL – 74ALS158

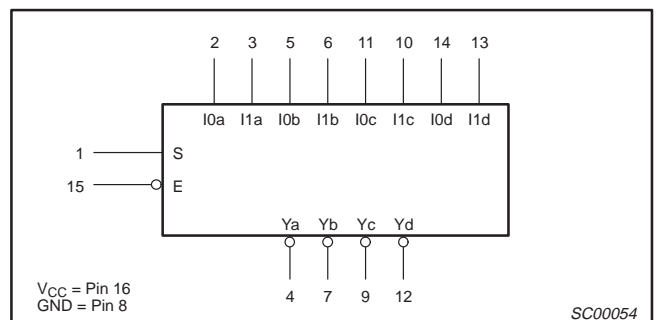

Data selector/multiplexer

74ALS157/74ALS158

IEC/IEEE SYMBOL – 74ALS157

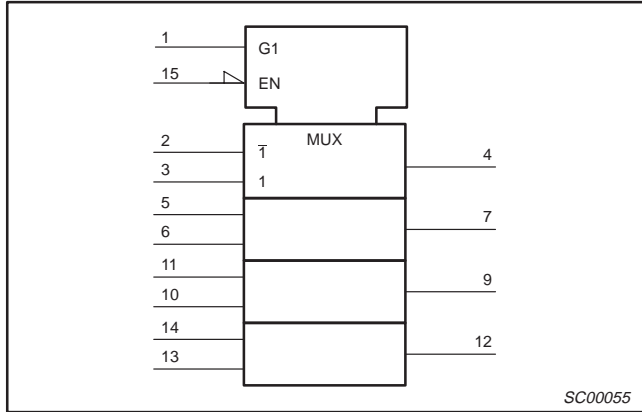

IEC/IEEE SYMBOL – 74ALS158

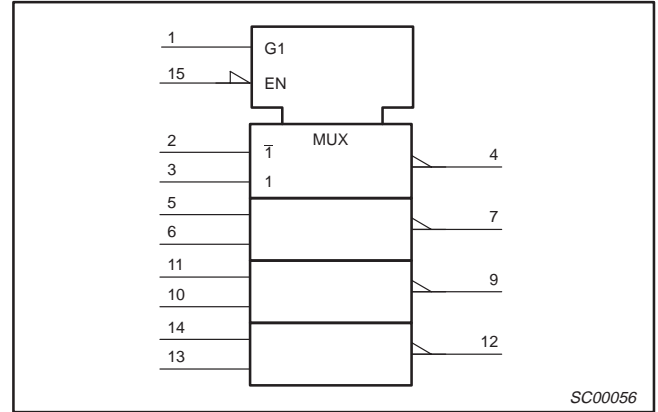

LOGIC DIAGRAM – 74ALS157

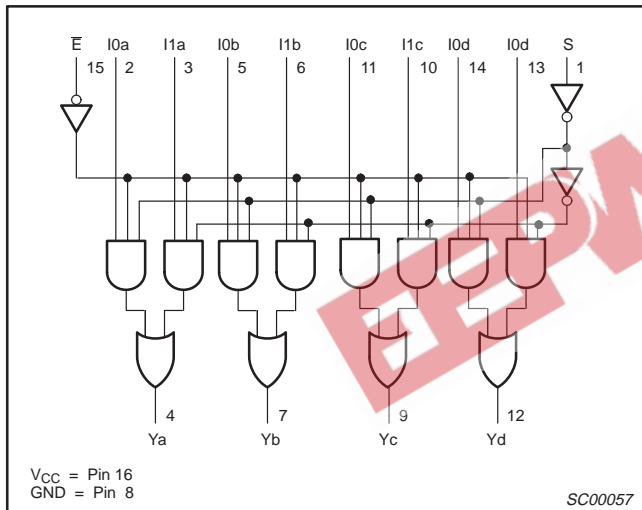

LOGIC DIAGRAM – 74ALS158

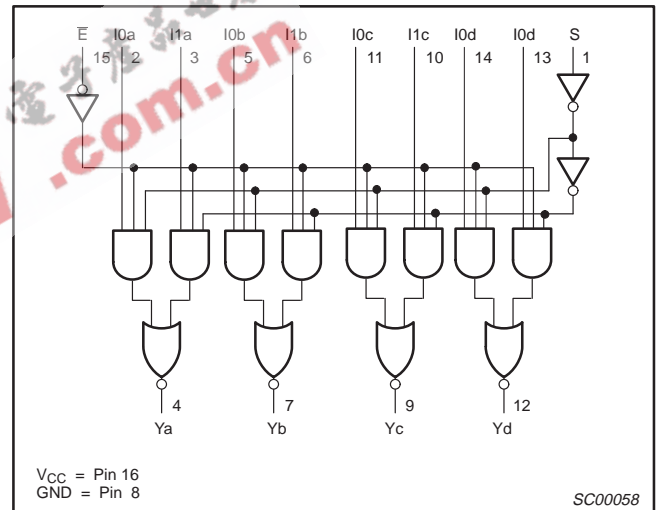

FUNCTION TABLE – 74ALS157

INPUTS				OUTPUTS
$\bar{E}$	S	I0n	I1n	Yn
H	X	X	X	L
L	L	L	X	L
L	L	H	X	H
L	H	X	L	L
L	H	X	H	H

H = High voltage level  
 L = Low voltage level  
 X = Don't care

FUNCTION TABLE – 74ALS158

INPUTS				OUTPUTS
$\bar{E}$	S	I0n	I1n	$\bar{Y}n$
H	X	X	X	H
L	L	L	X	H
L	L	H	X	L
L	H	X	L	H
L	H	X	H	L

H = High voltage level  
 L = Low voltage level  
 X = Don't care

## Data selector/multiplexer

## 74ALS157/74ALS158

**ABSOLUTE MAXIMUM RATINGS**

(Operation beyond the limit set forth in this table may impair the useful life of the device. Unless otherwise noted these limits are over the operating free-air temperature range.)

SYMBOL	PARAMETER	RATING	UNIT
$V_{CC}$	Supply voltage	-0.5 to +7.0	V
$V_{IN}$	Input voltage	-0.5 to +7.0	V
$I_{IN}$	Input current	-30 to +5	mA
$V_{OUT}$	Voltage applied to output in High output state	-0.5 to $V_{CC}$	V
$I_{OUT}$	Current applied to output in Low output state	16	mA
$T_{amb}$	Operating free-air temperature range	0 to +70	°C
$T_{stg}$	Storage temperature range	-65 to +150	°C

**RECOMMENDED OPERATING CONDITIONS**

SYMBOL	PARAMETER	LIMITS			UNIT
		MIN	NOM	MAX	
$V_{CC}$	Supply voltage	4.5	5.0	5.5	V
$V_{IH}$	High-level input voltage	2.0			V
$V_{IL}$	Low-level input voltage			0.8	V
$I_{IK}$	Input clamp current			-18	mA
$I_{OH}$	High-level output current			-0.4	mA
$I_{OL}$	Low-level output current			8	mA
$T_{amb}$	Operating free-air temperature range	0		+70	°C

**DC ELECTRICAL CHARACTERISTICS**

(Over recommended operating free-air temperature range unless otherwise noted.)

SYMBOL	PARAMETER	TEST CONDITIONS <sup>1</sup>	LIMITS			UNIT	
			MIN	TYP <sup>2</sup>	MAX		
$V_{OH}$	High-level output voltage	$V_{CC} = \pm 10\%$ , $V_{IL} = \text{MAX}$ , $V_{IH} = \text{MIN}$	$I_{OH} = \text{MAX}$	$V_{CC} - 2$		V	
$V_{OL}$	Low-level output voltage	$V_{CC} = \text{MIN}$ , $V_{IL} = \text{MAX}$ , $V_{IH} = \text{MIN}$	$I_{OL} = 4\text{mA}$		0.25	0.40	V
			$I_{OL} = 8\text{mA}$		0.35	0.50	V
$V_{IK}$	Input clamp voltage	$V_{CC} = \text{MIN}$ , $I_I = I_{IK}$		-0.73	-1.5	V	
$I_I$	Input current at minimum input voltage	$V_{CC} = \text{MAX}$ , $V_I = 7.0\text{V}$			0.1	mA	
$I_{IH}$	High-level input current	$V_{CC} = \text{MAX}$ , $V_I = 2.7\text{V}$			20	μA	
$I_{IL}$	Low-level input current	$V_{CC} = \text{MAX}$ , $V_I = 0.4\text{V}$			-0.1	mA	
$I_O$	Output current <sup>3</sup>	$V_{CC} = \text{MAX}$ , $V_O = 2.25\text{V}$		-30	-112	mA	
$I_{CC}$	Supply current (total)	74ALS157	$V_{CC} = \text{MAX}$		6	11	mA
		74ALS158			6	10	mA

**NOTES:**

- For conditions shown as MIN or MAX, use the appropriate value specified under recommended operating conditions for the applicable type.
- All typical values are at  $V_{CC} = 5\text{V}$ ,  $T_{amb} = 25^\circ\text{C}$ .
- The output conditions have been chosen to produce a current that closely approximates one half of the true short-circuit output current,  $I_{OS}$ .

Data selector/multiplexer

74ALS157/74ALS158

AC ELECTRICAL CHARACTERISTICS

SYMBOL	PARAMETER	TEST CONDITION	LIMITS		UNIT
			$T_{amb} = 0^{\circ}C \text{ to } +70^{\circ}C$ $V_{CC} = +5.0V \pm 10\%$ $C_L = 50pF, R_L = 500\Omega$		
			MIN	MAX	
$t_{PLH}$ $t_{PHL}$	Propagation delay I0n or I1n to Yn	Waveform 1	2.0	9.0	ns
$t_{PLH}$ $t_{PHL}$	Propagation delay S to Yn		2.0	9.0	
$t_{PLH}$ $t_{PHL}$	Propagation delay E to Yn		4.0	12.0	
$t_{PLH}$ $t_{PHL}$	Propagation delay S to $\bar{Y}n$	Waveform 1, 3	4.0	12.0	ns
$t_{PLH}$ $t_{PHL}$	Propagation delay E to $\bar{Y}n$		4.0	12.0	
$t_{PLH}$ $t_{PHL}$	Propagation delay I0n or I1n to $\bar{Y}n$		7.0	14.0	
$t_{PLH}$ $t_{PHL}$	Propagation delay I0n or I1n to $\bar{Y}n$	Waveform 2	2.0	8.0	ns
$t_{PLH}$ $t_{PHL}$	Propagation delay S to $\bar{Y}n$		2.0	8.0	
$t_{PLH}$ $t_{PHL}$	Propagation delay E to $\bar{Y}n$		4.0	12.0	
$t_{PLH}$ $t_{PHL}$	Propagation delay S to $\bar{Y}n$	Waveform 2, 4	4.0	12.0	ns
$t_{PLH}$ $t_{PHL}$	Propagation delay E to $\bar{Y}n$		4.0	12.0	
$t_{PLH}$ $t_{PHL}$	Propagation delay I0n or I1n to $\bar{Y}n$		4.0	14.0	
$t_{PLH}$ $t_{PHL}$	Propagation delay E to $\bar{Y}n$	Waveform 4	4.0	14.0	ns

AC WAVEFORMS

For all waveforms,  $V_M = 1.3V$ .

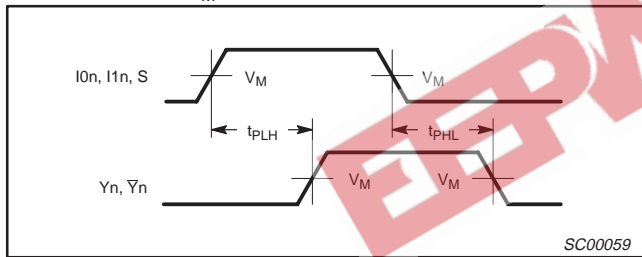

Waveform 1. Propagation Delay for Data and Select to Output

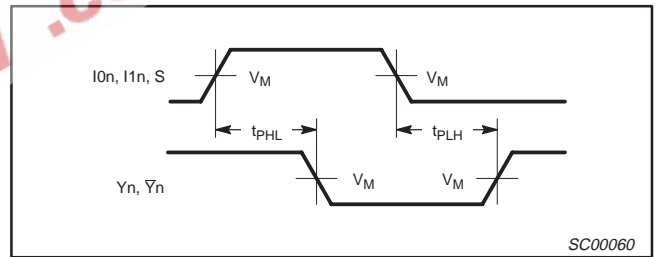

Waveform 2. Propagation Delay for Data and Select to Output

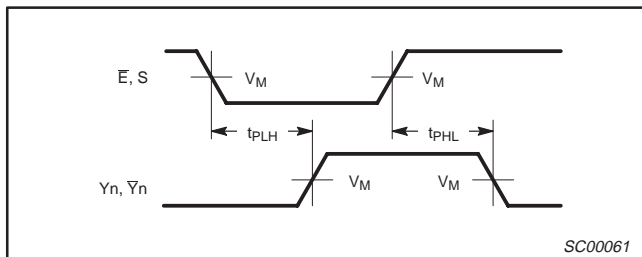

Waveform 3. Propagation Delay for Enable and Select to Output

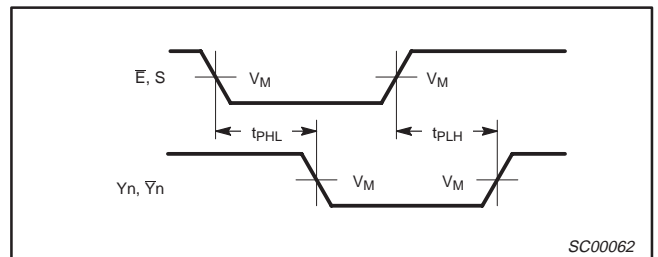

Waveform 4. Propagation Delay for Enable and Select to Output

Data selector/multiplexer

74ALS157/74ALS158

TEST CIRCUIT AND WAVEFORMS

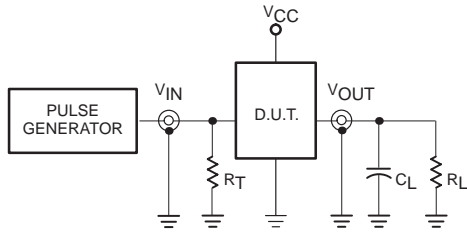

Test Circuit for Totem-pole Outputs

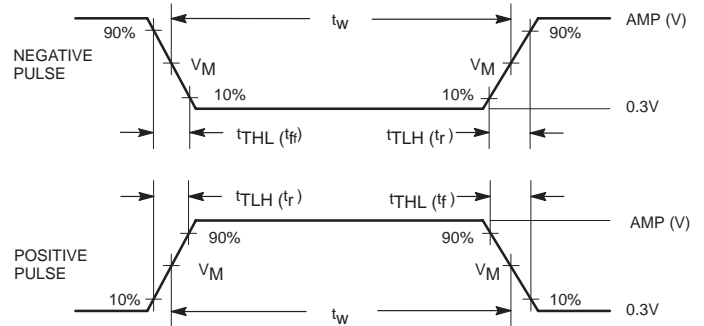

Input Pulse Definition

DEFINITIONS:

- $R_L$  = Load resistor; see AC electrical characteristics for value.
- $C_L$  = Load capacitance includes jig and probe capacitance; see AC electrical characteristics for value.
- $R_T$  = Termination resistance should be equal to  $Z_{OUT}$  of pulse generators.

Family	INPUT PULSE REQUIREMENTS					
	Amplitude	$V_M$	Rep.Rate	$t_w$	$t_{TLH}$	$t_{THL}$
74ALS	3.5V	1.3V	1MHz	500ns	2.0ns	2.0ns

SC00005

Data selector/multiplexer

74ALS157/74ALS158

DIP16: plastic dual in-line package; 16 leads (300 mil)

SOT38-4

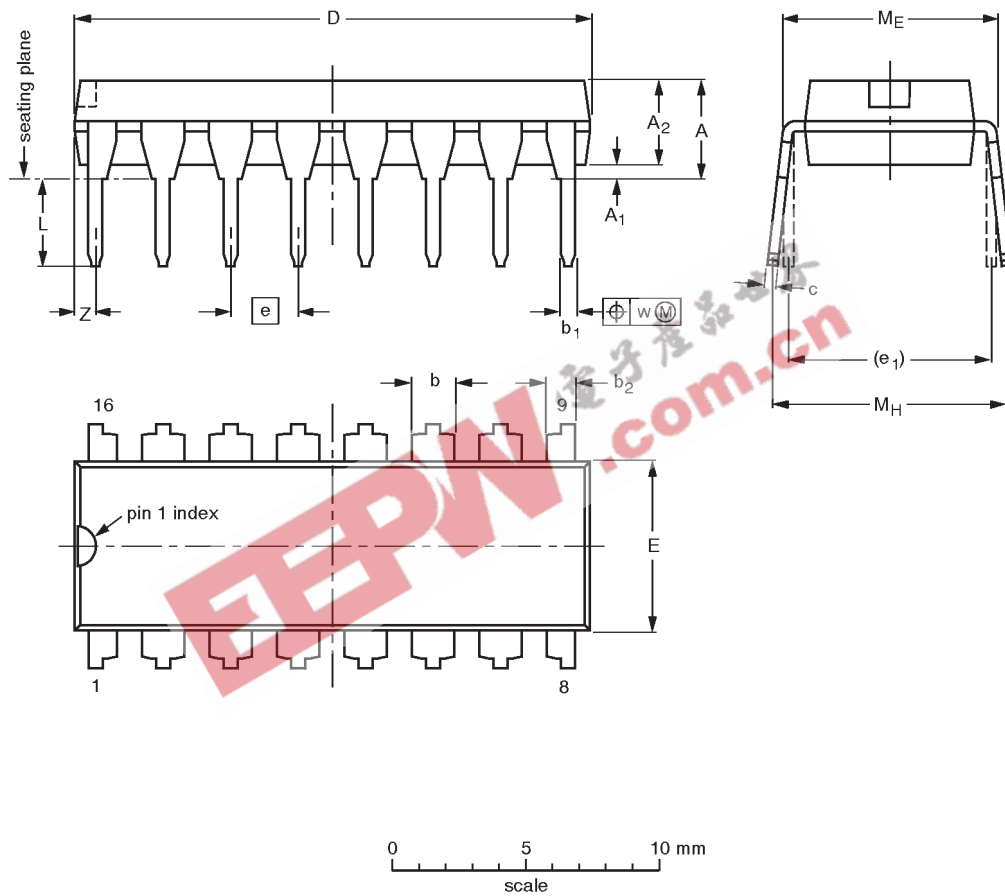

DIMENSIONS (inch dimensions are derived from the original mm dimensions)

UNIT	A max.	A <sub>1</sub> min.	A <sub>2</sub> max.	b	b <sub>1</sub>	b <sub>2</sub>	c	D <sup>(1)</sup>	E <sup>(1)</sup>	e	e <sub>1</sub>	L	M <sub>E</sub>	M <sub>H</sub>	w	z <sup>(1)</sup> max.
mm	4.2	0.51	3.2	1.73 1.30	0.53 0.38	1.25 0.85	0.36 0.23	19.50 18.55	6.48 6.20	2.54	7.62	3.60 3.05	8.25 7.80	10.0 8.3	0.254	0.76
inches	0.17	0.020	0.13	0.068 0.051	0.021 0.015	0.049 0.033	0.014 0.009	0.77 0.73	0.26 0.24	0.10	0.30	0.14 0.12	0.32 0.31	0.39 0.33	0.01	0.030

Note

1. Plastic or metal protrusions of 0.25 mm maximum per side are not included.

OUTLINE VERSION	REFERENCES				EUROPEAN PROJECTION	ISSUE DATE
	IEC	JEDEC	EIAJ			
SOT38-4						92-11-17 95-01-14

Data selector/multiplexer

74ALS157/74ALS158

SO16: plastic small outline package; 16 leads; body width 3.9 mm

SOT109-1

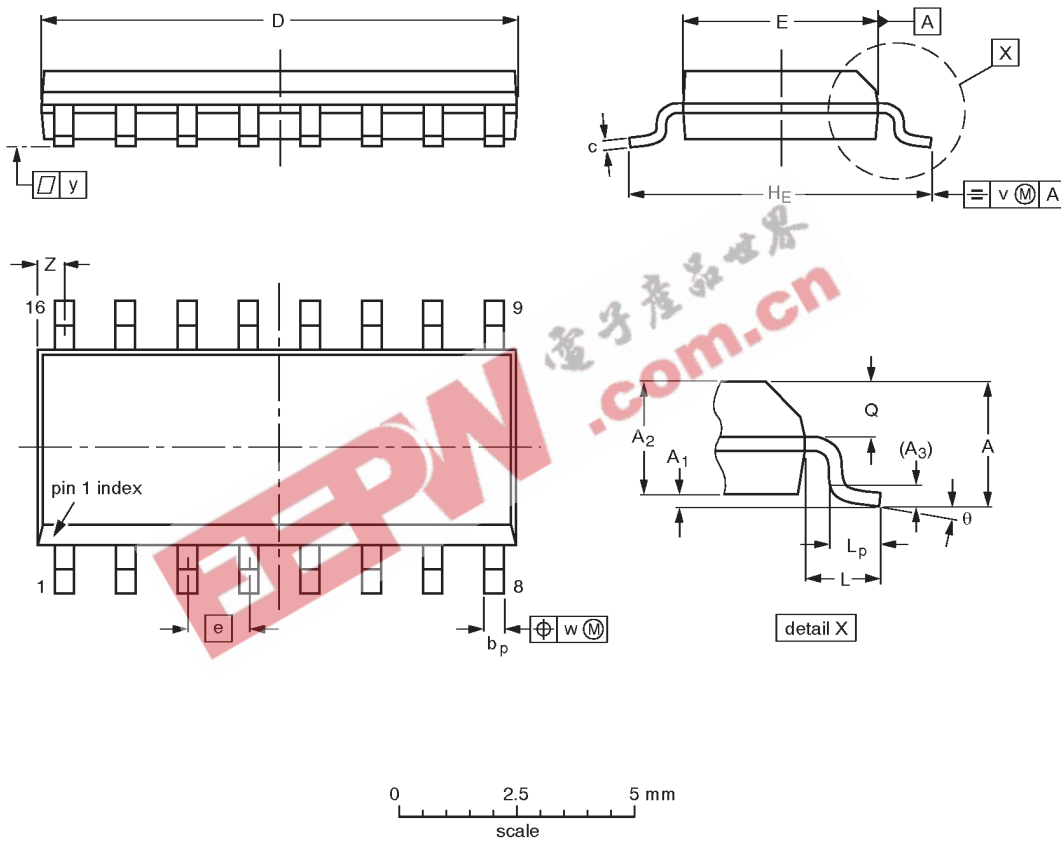

DIMENSIONS (inch dimensions are derived from the original mm dimensions)

UNIT	A max.	A <sub>1</sub>	A <sub>2</sub>	A <sub>3</sub>	b <sub>p</sub>	c	D <sup>(1)</sup>	E <sup>(1)</sup>	e	H <sub>E</sub>	L	L <sub>p</sub>	Q	v	w	y	Z <sup>(1)</sup>	$\theta$
mm	1.75	0.25 0.10	1.45 1.25	0.25	0.49 0.36	0.25 0.19	10.0 9.8	4.0 3.8	1.27	6.2 5.8	1.05	1.0 0.4	0.7 0.6	0.25	0.25	0.1	0.7 0.3	8° 0°
inches	0.069	0.0098 0.0039	0.057 0.049	0.01	0.019 0.014	0.0098 0.0075	0.39 0.38	0.16 0.15	0.050	0.24 0.23	0.041	0.039 0.016	0.028 0.020	0.01	0.01	0.004	0.028 0.012	

Note

1. Plastic or metal protrusions of 0.15 mm maximum per side are not included.

OUTLINE VERSION	REFERENCES				EUROPEAN PROJECTION	ISSUE DATE
	IEC	JEDEC	EIAJ			
SOT109-1	076E07S	MS-012AC				91-08-13 95-01-23



## Data selector/multiplexer

74ALS157/74ALS158

## DEFINITIONS

Data Sheet Identification	Product Status	Definition
<i>Objective Specification</i>	<b>Formative or in Design</b>	This data sheet contains the design target or goal specifications for product development. Specifications may change in any manner without notice.
<i>Preliminary Specification</i>	<b>Preproduction Product</b>	This data sheet contains preliminary data, and supplementary data will be published at a later date. Philips Semiconductors reserves the right to make changes at any time without notice in order to improve design and supply the best possible product.
<i>Product Specification</i>	<b>Full Production</b>	This data sheet contains Final Specifications. Philips Semiconductors reserves the right to make changes at any time without notice, in order to improve design and supply the best possible product.

Philips Semiconductors and Philips Electronics North America Corporation reserve the right to make changes, without notice, in the products, including circuits, standard cells, and/or software, described or contained herein in order to improve design and/or performance. Philips Semiconductors assumes no responsibility or liability for the use of any of these products, conveys no license or title under any patent, copyright, or mask work right to these products, and makes no representations or warranties that these products are free from patent, copyright, or mask work right infringement, unless otherwise specified. Applications that are described herein for any of these products are for illustrative purposes only. Philips Semiconductors makes no representation or warranty that such applications will be suitable for the specified use without further testing or modification.

## LIFE SUPPORT APPLICATIONS

Philips Semiconductors and Philips Electronics North America Corporation Products are not designed for use in life support appliances, devices, or systems where malfunction of a Philips Semiconductors and Philips Electronics North America Corporation Product can reasonably be expected to result in a personal injury. Philips Semiconductors and Philips Electronics North America Corporation customers using or selling Philips Semiconductors and Philips Electronics North America Corporation Products for use in such applications do so at their own risk and agree to fully indemnify Philips Semiconductors and Philips Electronics North America Corporation for any damages resulting from such improper use or sale.

Philips Semiconductors  
811 East Arques Avenue  
P.O. Box 3409  
Sunnyvale, California 94088-3409  
Telephone 800-234-7381

© Copyright Philips Electronics North America Corporation 1997  
All rights reserved. Printed in U.S.A.

*Let's make things better.*