

CD4024BM/CD4024BC 7-Stage Ripple Carry Binary Counter

General Description

The CD4024BM/CD4024BC is a 7-stage ripple-carry binary counter. Buffered outputs are externally available from stages 1 through 7. The counter is reset to its logical "0" stage by a logical "1" on the reset input. The counter is advanced one count on the negative transition of each clock pulse.

Features

- Wide supply voltage range 3.0V to 15V
- High noise immunity 0.45 V_{DD} (typ.)
- Low power TTL compatibility Fan out of 2 driving 74L or 1 driving 74LS
- High speed 12 MHz (typ.)
- input pulse rate $V_{DD} - V_{SS} = 10V$
- Fully static operation

Connection Diagram

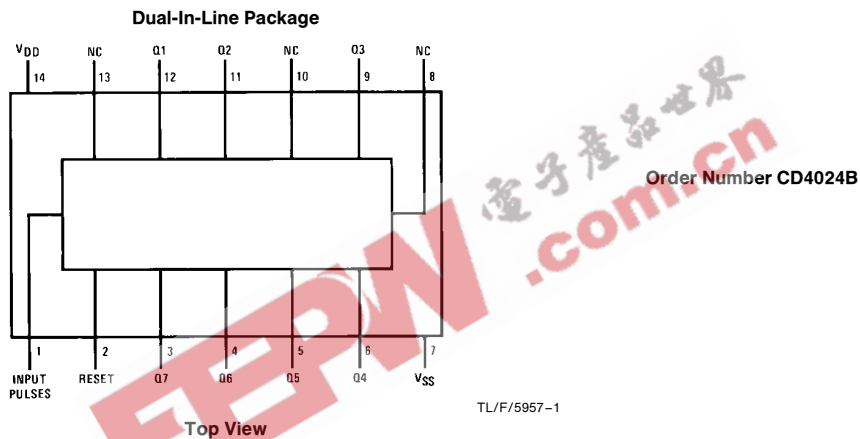

Schematic Diagrams

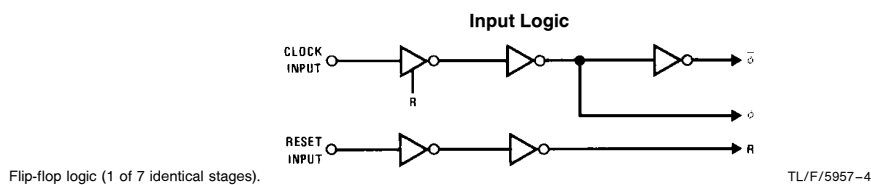
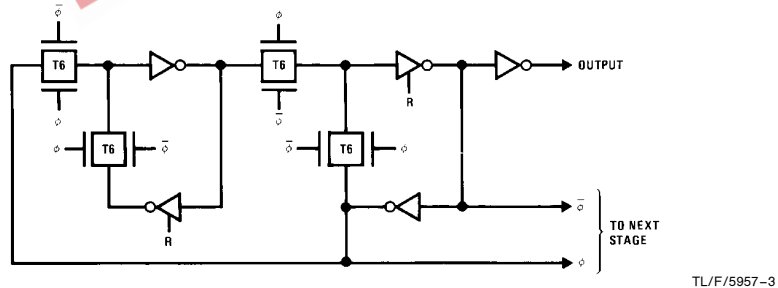

Absolute Maximum Ratings (Notes 1 & 2)

If Military/Aerospace specified devices are required, please contact the National Semiconductor Sales Office/Distributors for availability and specifications.

DC Supply Voltage (V_{DD})	-0.5 to +18 V_{DC}
Input Voltage (V_{IN})	-0.5 to V_{DD} + 0.5 V_{DC}
Storage Temperature Range (T_S)	-65°C to +150°C
Power Dissipation (P_D)	
Dual-In-Line	700 mW
Small Outline	500 mW
Lead Temp. (Soldering, 10 sec.) (T_L)	260°C

Recommended Operating Conditions (Note 2)

DC Supply Voltage (V_{DD})	+3 to +15 V_{DC}
Input Voltage (V_{IN})	0 to V_{DD} V_{DC}
Operating Temperature Range (T_A)	
CD4024BM	-55°C to +125°C
CD4024BC	-40°C to +85°C

DC Electrical Characteristics CD4024BM (Note 2)

Symbol	Parameter	Conditions	-55°C		+25°C			+125°C		Units
			Min	Max	Min	Typ	Max	Min	Max	
I_{DD}	Quiescent Device Current	$V_{DD} = 5V$		5		0.3	5		150	μA
		$V_{DD} = 10V$		10		0.5	10		300	μA
		$V_{DD} = 15V$		20		0.7	20		600	μA
V_{OL}	Low Level Output Voltage	$ I_O < 1 \mu A$				0	0.05		0.05	V
		$V_{DD} = 5V$		0.05		0	0.05		0.05	V
		$V_{DD} = 15V$		0.05		0	0.05		0.05	V
V_{OH}	High Level Output Voltage	$ I_O < 1 \mu A$				5				V
		$V_{DD} = 5V$	4.95		4.95	10		4.95		V
		$V_{DD} = 15V$	9.95		9.95	15		9.95		V
V_{IL}	Low Level Input Voltage	$ I_O < 1 \mu A$				2				V
		$V_{DD} = 5V, V_O = 0.5V$ or 4.5V		1.5		4			1.5	V
		$V_{DD} = 10V, V_O = 1.0V$ or 9.0V		3.0		6			3.0	V
V_{IH}	High Level Input Voltage	$ I_O < 1 \mu A$				9				V
		$V_{DD} = 5V, V_O = 0.5V$ or 4.5V	3.5		3.5	6		3.5		V
		$V_{DD} = 10V, V_O = 1.0V$ or 9.0V	7.0		7.0	9		7.0		V
I_{OL}	Low Level Output Current (Note 3)	$V_{DD} = 5V, V_O = 0.4V$	0.64		0.51	0.88		0.36		mA
		$V_{DD} = 10V, V_O = 0.5V$	1.6		1.3	2.25		0.9		mA
		$V_{DD} = 15V, V_O = 1.5V$	4.2		3.4	8.8		2.4		mA
I_{OH}	High Level Output Current (Note 3)	$V_{DD} = 5V, V_O = 4.6V$	-0.64		-0.51	-0.88		-0.36		mA
		$V_{DD} = 10V, V_O = 9.5V$	-1.6		-1.3	-2.25		-0.9		mA
		$V_{DD} = 15V, V_O = 13.5V$	-4.2		-3.4	-8.8		-2.4		mA
I_{IN}	Input Current	$V_{DD} = 15V, V_{IN} = 0V$		-0.10		-10^{-5}	-0.10		-1.0	μA
		$V_{DD} = 15V, V_{IN} = 15V$		0.10		10^{-5}	0.10		1.0	μA

DC Electrical Characteristics CD4024BC (Note 2)

Symbol	Parameter	Conditions	-40°C		+25°C			+85°C		Units
			Min	Max	Min	Typ	Max	Min	Max	
I_{DD}	Quiescent Device Current	$V_{DD} = 5V$		20		0.3	20		150	μA
		$V_{DD} = 10V$		40		0.5	40		300	μA
		$V_{DD} = 15V$		60		0.7	80		600	μA
V_{OL}	Low Level Output Voltage	$ I_O < 1 \mu A$				0	0.05		0.05	V
		$V_{DD} = 5V$		0.05		0	0.05		0.05	V
		$V_{DD} = 15V$		0.05		0	0.05		0.05	V
V_{OH}	High Level Output Voltage	$ I_O < 1 \mu A$				5				V
		$V_{DD} = 5V$	4.95		4.95	10		4.95		V
		$V_{DD} = 15V$	9.95		9.95	15		9.95		V

DC Electrical Characteristics CD4024BC (Note 2) (Continued)										
Symbol	Parameter	Conditions	-40°C		+25°C			+85°C		Units
			Min	Max	Min	Typ	Max	Min	Max	
V _{IL}	Low Level Input Voltage	I _O < 1 μA		1.5		2	1.5		1.5	V
		V _{DD} = 5V, V _O = 0.5V or 4.5V		3.0		4	3.0		3.0	V
		V _{DD} = 10V, V _O = 1.0V or 9.0V V _{DD} = 15V, V _O = 1.5V or 13.5V		4.0		6	4.0		4.0	V
V _{IH}	High Level Input Voltage	I _O < 1 μA								
		V _{DD} = 5V, V _O = 0.5V or 4.5V	3.5		3.5	3		3.5		V
		V _{DD} = 10V, V _O = 1.0V or 9.0V V _{DD} = 15V, V _O = 1.5V or 13.5V	7.0 11.0		7.0 11.0	6 9		7.0 11.0		V V V
I _{OL}	Low Level Output Current (Note 3)	V _{DD} = 5V, V _O = 0.4V	0.52		0.44	0.88		0.36		mA
		V _{DD} = 10V, V _O = 0.5V	1.3		1.1	2.25		0.9		mA
		V _{DD} = 15V, V _O = 1.5V	3.6		3.0	8.8		2.4		mA
I _{OH}	High Level Output Current (Note 3)	V _{DD} = 5V, V _O = 4.6V	-0.52		-0.44	-0.88		-0.36		mA
		V _{DD} = 10V, V _O = 9.5V	-1.3		-1.1	-2.25		-0.9		mA
		V _{DD} = 15V, V _O = 13.5V	-3.6		-3.0	-8.8		-2.4		mA
I _{IN}	Input Current	V _{DD} = 15V, V _{IN} = 0V V _{DD} = 15V, V _{IN} = 15V		-0.30 0.30		-10 ⁻⁵ 10 ⁻⁵	-0.30 0.30		-1.0 1.0	μA μA

AC Electrical Characteristics*						
T _A = 25°C, C _L = 50 pF, R _L = 200 k, t _r and t _f = 20 ns unless otherwise specified						
Symbol	Parameter	Conditions	Min	Typ	Max	Units
t _{PHL} , t _{PLH}	Propagation Delay Time to Q1 Output	V _{DD} = 5V		185	350	ns
		V _{DD} = 10V		85	125	ns
		V _{DD} = 15V		70	100	ns
t _{THL} , t _{TLH}	Transition Time	V _{DD} = 5V		100	200	ns
		V _{DD} = 10V		50	100	ns
		V _{DD} = 15V		40	80	ns
t _{WL} , t _{WH}	Minimum Input Pulse Width	V _{DD} = 5V		75	200	ns
		V _{DD} = 10V		40	110	ns
		V _{DD} = 15V		35	90	ns
t _{RCL} , t _{FCL}	Input Rise and Fall Time	V _{DD} = 5V			15	μs
		V _{DD} = 10V			10	μs
		V _{DD} = 15V			8	μs
f _{CL}	Maximum Input Pulse Frequency	V _{DD} = 5V	1.5	5		MHz
		V _{DD} = 10V	4	12		MHz
		V _{DD} = 15V	5	15		MHz
t _{PHL}	Reset Propagation Delay Time	V _{DD} = 5V		185	350	ns
		V _{DD} = 10V		85	125	ns
		V _{DD} = 15V		70	100	ns
t _{WH}	Reset Minimum Pulse Width	V _{DD} = 5V		185	350	ns
		V _{DD} = 10V		85	125	ns
		V _{DD} = 15V		70	100	ns
C _{IN}	Input Capacitance (Note 4)	Any Input		5	7.5	pF

*AC Parameters are guaranteed by DC correlated testing.

Note 1: "Absolute Maximum Ratings" are those values beyond which the safety of the device cannot be guaranteed, they are not meant to imply that the devices should be operated at these limits. The table of "Recommended Operating Conditions" and "Electrical Characteristics" provides conditions for actual device operation.

Note 2: V_{SS} = 0V unless otherwise specified.

Note 3: I_{OH} and I_{OL} are tested one output at a time.

Note 4: Capacitance is guaranteed by periodic testing.

Logic Diagram

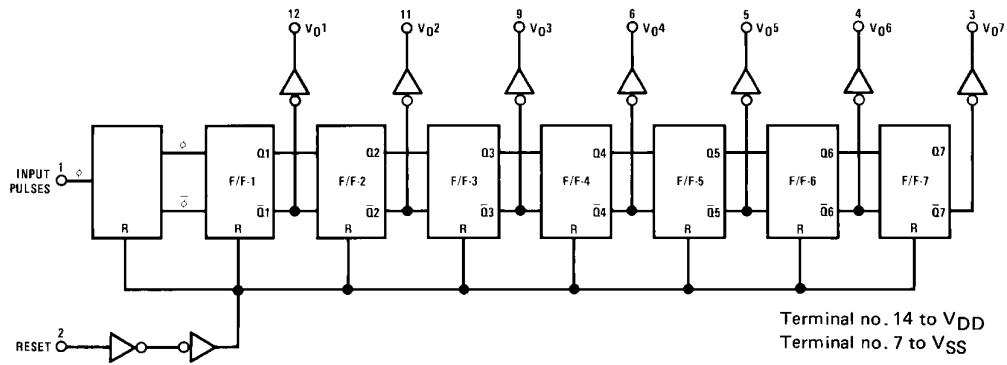

TL/F/5957-2

EEPW 电子产品世界 .com.cn

Physical Dimensions inches (millimeters)

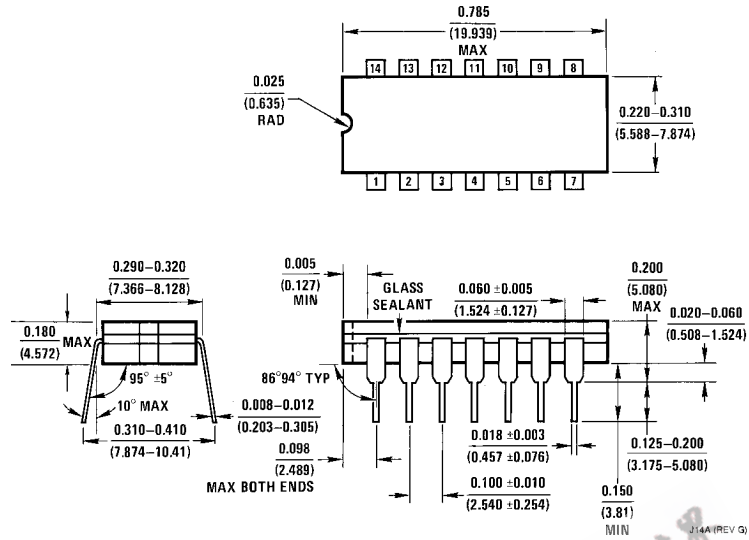

Ceramic Dual-In-Line Package (J)
Order Number CD4024BMJ or CD402BCJ
NS Package Number J14A

EEPW.com.cn 电子产品世界

Physical Dimensions inches (millimeters) (Continued)

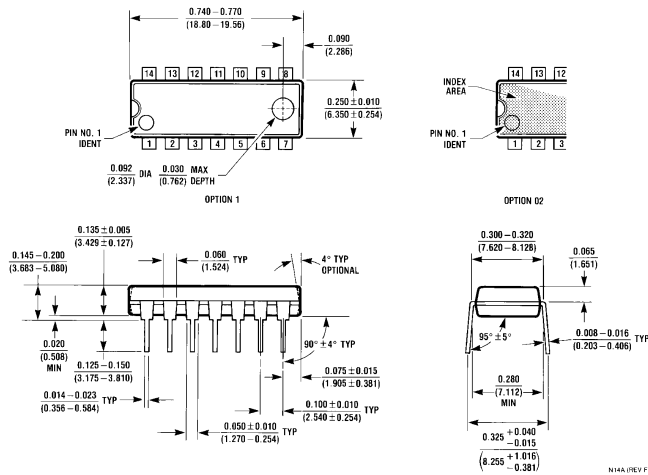

Molded Dual-In-Line Package (N)
Order Number CD4024BMN or CD402BCN
NS Package Number N14A



LIFE SUPPORT POLICY

NATIONAL'S PRODUCTS ARE NOT AUTHORIZED FOR USE AS CRITICAL COMPONENTS IN LIFE SUPPORT DEVICES OR SYSTEMS WITHOUT THE EXPRESS WRITTEN APPROVAL OF THE PRESIDENT OF NATIONAL SEMICONDUCTOR CORPORATION. As used herein:

1. Life support devices or systems are devices or systems which, (a) are intended for surgical implant into the body, or (b) support or sustain life, and whose failure to perform, when properly used in accordance with instructions for use provided in the labeling, can be reasonably expected to result in a significant injury to the user.
2. A critical component is any component of a life support device or system whose failure to perform can be reasonably expected to cause the failure of the life support device or system, or to affect its safety or effectiveness.



National Semiconductor Corporation
 1111 West Bardin Road
 Arlington, TX 76017
 Tel: 1(800) 272-9959
 Fax: 1(800) 737-7018

National Semiconductor Europe
 Fax: (+49) 0-180-530 85 86
 Email: cnjwge@levm2.nsc.com
 Deutsch Tel: (+49) 0-180-530 85 85
 English Tel: (+49) 0-180-532 78 32
 Français Tel: (+49) 0-180-532 93 58
 Italiano Tel: (+49) 0-180-534 16 80

National Semiconductor Hong Kong Ltd.
 13th Floor, Straight Block,
 Ocean Centre, 5 Canton Rd.
 Tsimshatsui, Kowloon
 Hong Kong
 Tel: (852) 2737-1600
 Fax: (852) 2736-9960

National Semiconductor Japan Ltd.
 Tel: 81-043-299-2309
 Fax: 81-043-299-2408

National does not assume any responsibility for use of any circuitry described, no circuit patent licenses are implied and National reserves the right at any time without notice to change said circuitry and specifications.