

DATA SHEET

For a complete data sheet, please also download:

- The IC06 74HC/HCT/HCU/HCMOS Logic Family Specifications
- The IC06 74HC/HCT/HCU/HCMOS Logic Package Information
- The IC06 74HC/HCT/HCU/HCMOS Logic Package Outlines

EEPW 电子产品世界
.com.cn

74HC4050

Hex high-to-low level shifter

Product specification
File under Integrated Circuits, IC06

December 1990

Hex high-to-low level shifter

74HC4050

FEATURES

- Output capability: standard
- I_{CC} category: SSI

GENERAL DESCRIPTION

The 74HC4050 is a high-speed Si-gate CMOS device and is pin compatible with the "4050" of the "4000B" series. It is specified in compliance with JEDEC standard no. 7A.

The 74HC4050 provides six non-inverting buffers with a modified input protection structure, which has no diode connected to V_{CC}. Input voltages of up to 15 V may

therefore be used. This feature enables the non-inverting buffers to be used as logic level translators, which will convert high level logic to low level logic, while operating from a low voltage power supply. For example 15 V logic ("4000B series") can be converted down to 2 V logic.

The actual input switch level remains related to the V_{CC} and is the same as mentioned in the family characteristics.

APPLICATIONS

- Converting 15 V logic ("4000B" series) down to 2 V logic.

QUICK REFERENCE DATA

GND = 0 V; T_{amb} = 25 °C; t_r = t_f = 6 ns

SYMBOL	PARAMETER	CONDITIONS	TYPICAL	UNIT
			HC	
t _{PHL} / t _{PLH}	propagation delay nA to nY	C _L = 15 pF; V _{CC} = 5 V	7	ns
C _I	input capacitance		3.5	pF
C _{PD}	power dissipation capacitance per buffer	note 1	14	pF

Notes

1. C_{PD} is used to determine the dynamic power dissipation (P_D in μW):

$$P_D = C_{PD} \times V_{CC}^2 \times f_i + \sum (C_L \times V_{CC}^2 \times f_o) \text{ where:}$$

f_i = input frequency in MHz

f_o = output frequency in MHz

C_L = output load capacitance in pF

V_{CC} = supply voltage in V

$\sum (C_L \times V_{CC}^2 \times f_o)$ = sum of outputs

ORDERING INFORMATION

See "74HC/HCT/HCU/HCMOS Logic Package Information".

Hex high-to-low level shifter

74HC4050

PIN DESCRIPTION

PIN NO.	SYMBOL	NAME AND FUNCTION
1	V _{CC}	positive supply voltage
2, 4, 6, 10, 12, 15	1Y to 6Y	data outputs
3, 5, 7, 9, 11, 14	1A to 6A	data inputs
8	GND	ground (0 V)
13, 16	n.c.	not connected

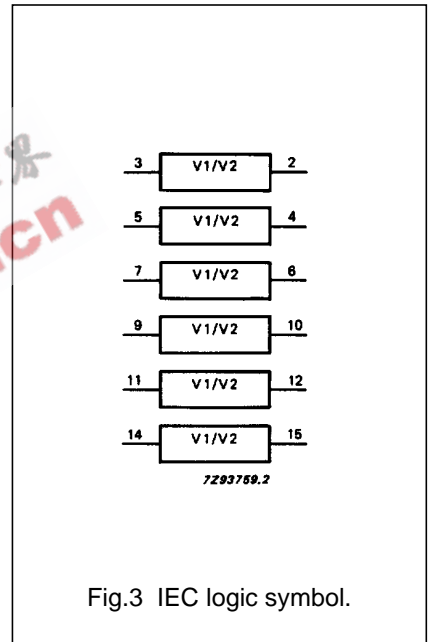
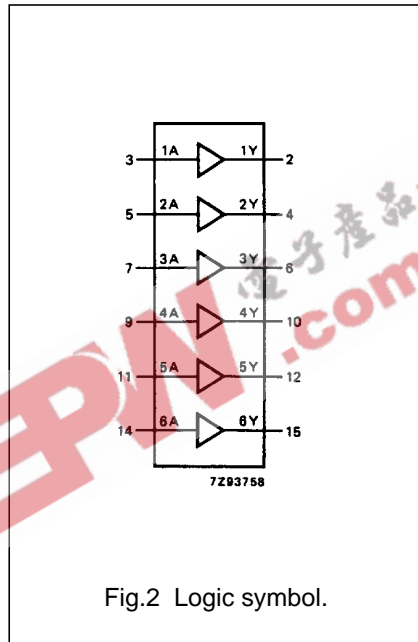
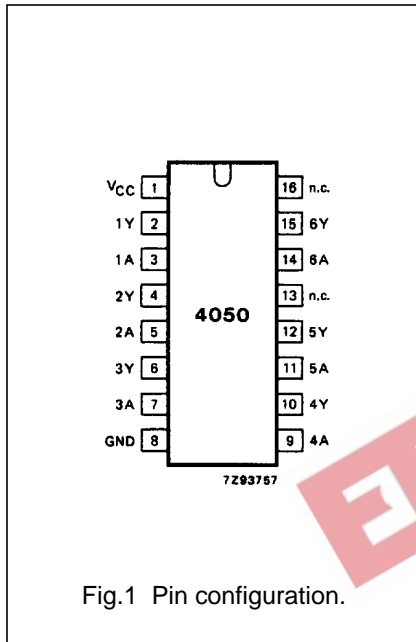

Hex high-to-low level shifter

74HC4050

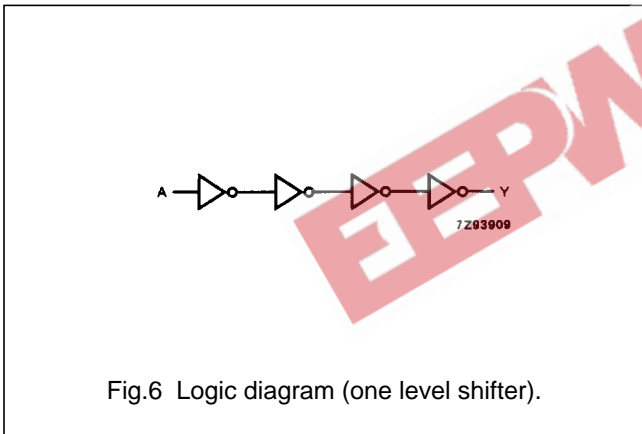
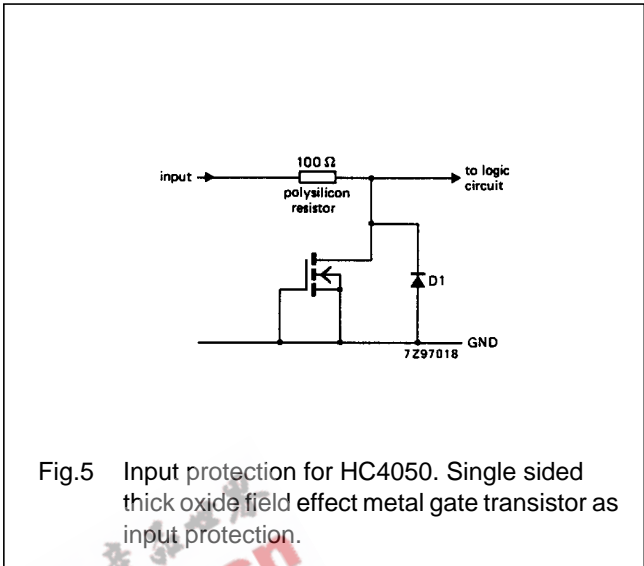
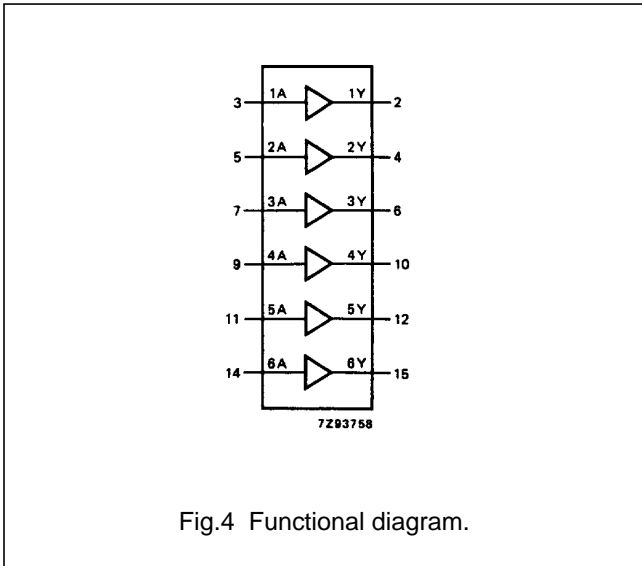

FUNCTION TABLE (1)

INPUT	OUTPUT
nA	nY
L	L
H	H

Note

- 1. H = HIGH voltage level
L = LOW voltage level

Hex high-to-low level shifter

74HC4050

RATINGS

Limiting values in accordance with the Absolute Maximum System (IEC 134)

Voltages are referenced to GND (ground = 0 V)

SYMBOL	PARAMETER	MIN.	MAX.	UNIT	CONDITIONS
V_{CC}	DC supply voltage	-0.5	+7	V	
V_{IK}	DC input voltage range	-0.5	+16	V	
$-I_{IK}$	DC input diode current		20	mA	for $V_I < -0.5$ V
$\pm I_{OK}$	DC output diode current		20	mA	for $V_O < -0.5$ V or $V_O > V_{CC} + 0.5$ V
$\pm I_O$	DC output source or sink current - standard outputs		25	mA	for -0.5 V $< V_O < V_{CC} + 0.5$ V
$\pm I_{CC}$; $\pm I_{GND}$	DC V_{CC} or GND current for types with: - standard outputs		50	mA	
T_{stg}	storage temperature range	-65	+150	°C	
P_{tot}	power dissipation per package				for temperature range: -40 to +125 °C 74HC
	plastic DIL		750	mW	above +70 °C: derate linearly with 12 mW/K
	plastic mini-pack (SO)		500	mW	above +70 °C: derate linearly with 8 mW/K

RECOMMENDED OPERATING CONDITIONS

SYMBOL	PARAMETER	74HC			UNIT	CONDITIONS
		min.	typ.	max.		
V_{CC}	DC supply voltage	2.0	5.0	6.0	V	
V_I	DC input voltage range	GND	-	15	V	
T_{amb}	operating ambient temperature range	-40		+85	°C	see DC and AC characteristics
T_{amb}	operating ambient temperature range	-40		+125	°C	
t_r, t_f	input rise and fall times		6.0	1000 500 400 650 1000	ns	$V_{CC} = 2.0$ V; $V_{IN} = 2.0$ V $V_{CC} = 4.5$ V; $V_{IN} = 4.5$ V $V_{CC} = 6.0$ V; $V_{IN} = 6.0$ V $V_{CC} = 6.0$ V; $V_{IN} = 10.0$ V $V_{CC} = 6.0$ V; $V_{IN} = 15.0$ V

Hex high-to-low level shifter

74HC4050

DC CHARACTERISTICS FOR 74HC

Voltages are referenced to GND (ground = 0 V)

SYMBOL	PARAMETER	T _{amb} (°C)							UNIT	TEST CONDITIONS		
		74HC								V _{CC} (V)	V _I	OTHER
		+25			-40 to +85		-40 to +125					
		min.	typ.	max.	min.	max.	min.	max.				
V _{IH}	HIGH level input voltage	1.5 3.15 4.2	1.3 2.4 3.1		1.5 3.15 4.2		1.5 3.15 4.2		V	2.0 4.5 6.0		
V _{IL}	LOW level input voltage		0.7 1.8 2.3	0.5 1.35 1.8		0.5 1.35 1.8		0.5 1.35 1.8	V	2.0 4.5 6.0		
V _{OH}	HIGH level output voltage - all outputs	1.9 4.4 5.9	2.0 4.5 6.0		1.9 4.4 5.9		1.9 4.4 5.9		V	2.0 4.5 6.0	V _{IH} or V _{IL}	-I _O = 20 µA -I _O = 20 µA -I _O = 20 µA
V _{OH}	HIGH level output voltage - standard outputs	3.98 5.48			3.84 5.34		3.7 5.2		V	4.5 6.0	V _{IH} or V _{IL}	-I _O = 4.0 mA -I _O = 5.2 mA
V _{OL}	LOW level output voltage - all outputs			0.1 0.1 0.1		0.1 0.1 0.1		0.1 0.1 0.1	V	2.0 4.5 6.0	V _{IH} or V _{IL}	I _O = 20 µA I _O = 20 µA I _O = 20 µA
V _{OL}	LOW level output voltage - standard outputs			0.26 0.26		0.33 0.33		0.4 0.4	V	4.5 6.0	V _{IH} or V _{IL}	I _O = 4.0 mA I _O = 5.2 mA
± I _I	input leakage current			0.1		1.0		1.0	µA	6.0	V _{CC} or GND	
				0.5		5.0		5.0	µA	2.0 to 6.0	15 V	
I _{CC}	quiescent supply current			2.0		20.0		40.0	µA	6.0	15 V or GND	

Hex high-to-low level shifter

74HC4050

AC CHARACTERISTICS FOR 74HC

GND = 0 V; $t_r = t_f = 6$ ns; $C_L = 50$ pF

SYMBOL	PARAMETER	T _{amb} (°C)						UNIT	TEST CONDITIONS		
		74HC							V _{CC} (V)	WAVEFORMS	
		+25			-40 to +85		-40 to +125				
		min.	typ.	max.	min.	max.	min.				max.
t _{PHL} / t _{PLH}	propagation delay nA to nY		25 9 7	85 17 14		105 21 18		130 26 22	ns	2.0 4.5 6.0	Fig.7
t _{THL} / t _{TLH}	output transition time		19 7 6	75 15 13		95 19 16		110 22 19	ns	2.0 4.5 6.0	Fig.7

AC WAVEFORMS

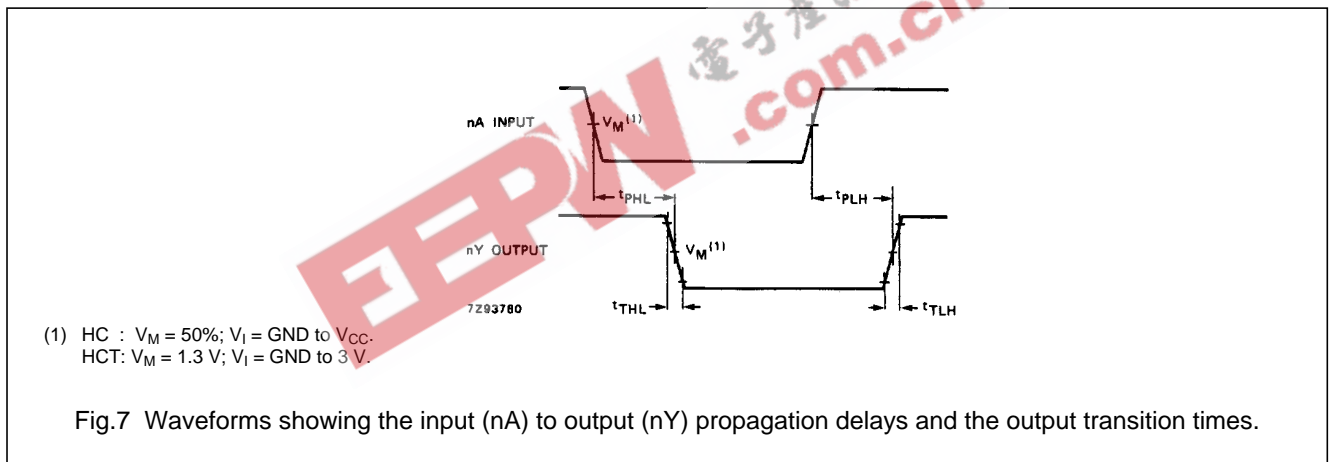

Fig.7 Waveforms showing the input (nA) to output (nY) propagation delays and the output transition times.

PACKAGE OUTLINES

See "74HC/HCT/HCU/HCMOS Logic Package Outlines".