

SN54LS56, SN54LS57, SN74LS56, SN74LS57 FREQUENCY DIVIDERS

SDLS182

DECEMBER 1983—REVISED MARCH 1988

- 'LS56 Performs 50 to 1 Frequency Division (5 to 1, 5 to 1, and 10 to 1)
- 'LS57 Performs 60 to 1 Frequency Division (6 to 1, 5 to 1, and 10 to 1)
- Available in P or JG package (two P or JG Packages Fit in a Single 16-pin Socket)
- Maximum Clock Frequency 25 MHz Typical

SN54LS56, SN54LS57 . . . JG PACKAGE
SN74LS56, SN74LS57 . . . JG OR P PACKAGE

(TOP VIEW)

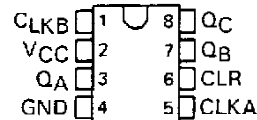

FOR CHIP CARRIER INFORMATION, CONTACT THE FACTORY.

description

These frequency dividers are particularly useful in generating one second or one hour timing pulses from 50 Hz (European standard frequency) or 60 Hz (United States standard frequency). 50 to 1 frequency division is accomplished in the 'LS56 by connecting output Q_A to input CLKB. 60 to 1 frequency division in the 'LS57 is accomplished in the same way. More universal capabilities are evidenced by the 25 MHz typical f_{max} and the almost limitless frequency division possibilities when used in cascade. Two 'LS56 packages may be interconnected to give frequency division of 2500 to 1, 625 to 1, 100 to 1, etc. Two 'LS57 packages can be connected to generate frequency divisions of 3600 to 1, 1800 to 1, 900 to 1 etc.

The 'LS56 and 'LS57 frequency dividers consist of three separate counters, A, B, and C on a single monolithic substrate. The A counter divides by 5 to 1 in the 'LS56 and by 6 to 1 in the 'LS57. The B counter divides by 5 to 1 in both devices and is internally tied to the C counter which divides by 2 to 1. The resulting C counter output is 10 to 1. Both the 'LS56 and 'LS57 feature a clear pin which is common to all three counters, A, B, and C. When the clear pin is low, the counters are enabled. When the clear is high, the counters are disabled and their outputs are set to a low-level.

All three counters, A, B, and C trigger on the high-to-low transition of the clock input. All output waveforms are symmetrical except for the 5 to 1 outputs (A and B of the 'LS56 and B of the 'LS57). See the output waveform drawings below.

input and output waveforms

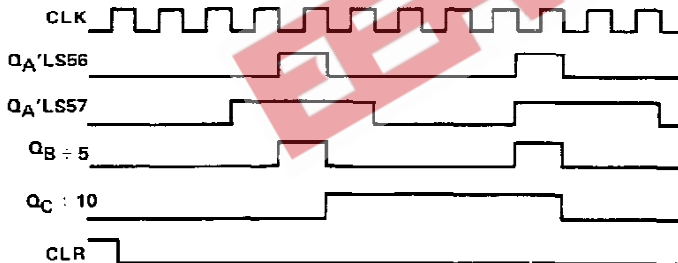

logic diagram (positive logic)

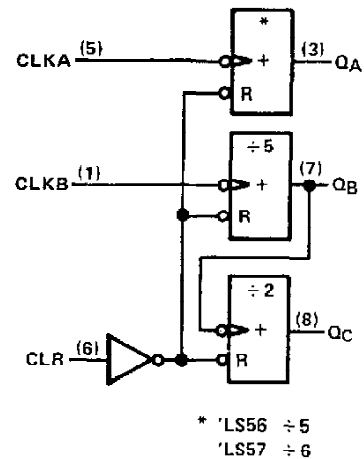

logic symbols†

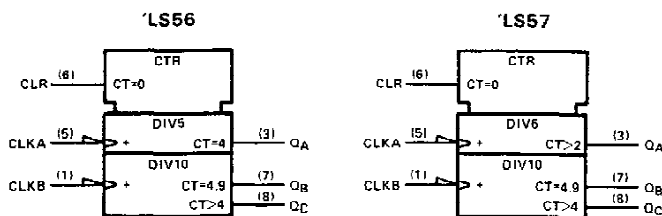

†These symbols are in accordance with ANSI/IEEE Std 91-1984 and IEC Publication 617-12.

PRODUCTION DATA documents contain information current as of publication data. Products conform to specifications per the terms of Texas Instruments standard warranty. Production processing does not necessarily include testing of all parameters.

TEXAS
INSTRUMENTS

POST OFFICE BOX 655012 • DALLAS, TEXAS 75265

SN54LS56, SN54LS57, SN74LS56, SN74LS57 FREQUENCY DIVIDERS

schematics of inputs and outputs

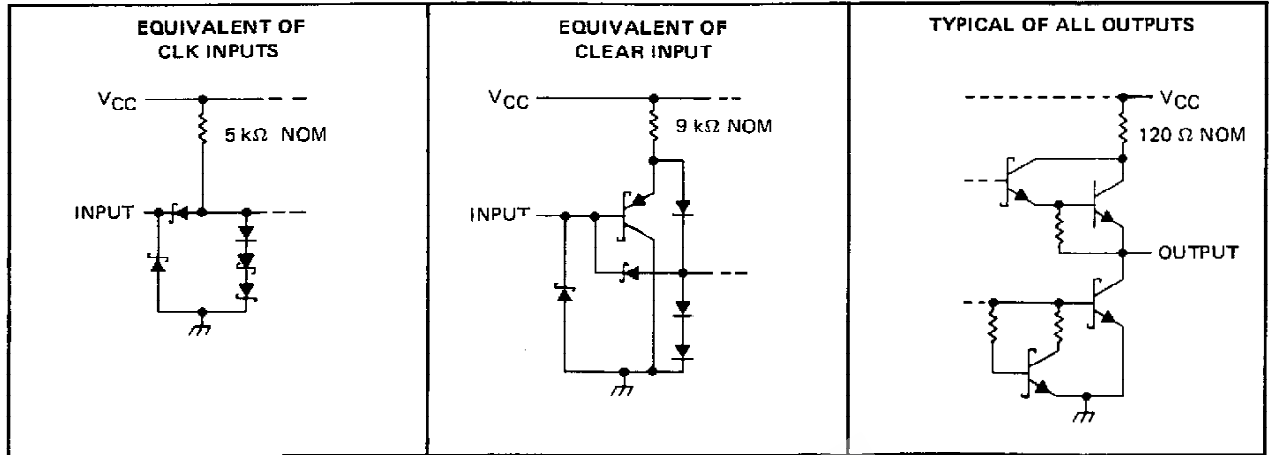

absolute maximum ratings over operating free-air temperature (unless otherwise noted)

Supply voltage, V_{CC} (see Note 1)	7 V
Input voltage: CLR	7 V
CLKA, CLKB	5.5 V
Operating free-air temperature range: SN54LS'	-55°C to 125°C
SN74LS'	-0°C to 70°C
Storage temperature range	-65°C to 150°C

NOTE 1: Voltage values are with respect to network ground terminal.

recommended operating conditions

	SN54LS'			SN74LS'			UNIT
	MIN	NOM	MAX	MIN	NOM	MAX	
V_{CC} Supply voltage	4.5	5	5.5	4.75	5	5.25	V
V_{IH} High-level input voltage	2			2			V
V_{IL} Low-level input voltage			0.7			0.8	V
I_{OH} High-level output current			-1			-1	mA
I_{OL} Low-level output current			8			16	mA
f_{clock} Clock frequency	0		15	0		15	MHz
t_r, t_f Rise and fall time of clock			50			50	ns
t_w Pulse width of clock or clear	30			30			ns
t_{su} Clear inactive state set-up time	25			25			ns
T_A Operating free-air temperature	-55		125	0		70	°C

SN54LS56, SN54LS57, SN74LS56, SN74LS57 FREQUENCY DIVIDERS

electrical characteristics over recommended operating free-air temperature range (unless otherwise noted)

PARAMETER	TEST CONDITIONS†	SN54LS'			SN74LS'			UNIT
		MIN	TYP‡	MAX	MIN	TYP‡	MAX	
V_{IK}	$V_{CC} = \text{MIN}, I_I = -18 \text{ mA}$	-1.5			-1.5			V
V_{OH}	$V_{CC} = \text{MIN}, V_{IH} = 2 \text{ V}, V_{IL} = \text{MAX}, I_{OH} = -1 \text{ mA}$	2.5	3.4		2.7	3.4		V
V_{OL}	$V_{CC} = \text{MIN}, V_{IH} = 2 \text{ V}, V_{IL} = \text{MAX}, I_{OL} = 8 \text{ mA}$	0.25 0.4			0.25 0.4			V
		$I_{OL} = 16 \text{ mA}$			0.35 0.5			
I_I	CLKA, CLKB	$V_{CC} = \text{MAX}$			$V_I = 5.5 \text{ V}$			0.2
	CLR				$V_I = 7 \text{ V}$			0.1
I_{IH}	CLKA, CLKB	$V_{CC} = \text{MAX}, V_I = 2.7 \text{ V}$			80			80
	CLR				20			20
I_{IL}	CLKA, CLKB	$V_{CC} = \text{MAX}, \text{CLR} = 0 \text{ V}, V_I = 0.4 \text{ V}$			-3.2			-3.2
	CLR				-0.2			-0.2
$I_{OS}§$	$V_{CC} = \text{MAX}, \text{CLR} = 0 \text{ V}, V_O = 0 \text{ V}$	-20	-100		-20	-100		mA
I_{CC}	$V_{CC} = \text{MAX},$ See Note 2	17 30			17 30			mA

† For conditions shown as MIN or MAX, use the appropriate value specified under recommended operating conditions.

‡ All typical values are at $V_{CC} = 5 \text{ V}, T_A = 25^\circ \text{C}$.

§ Not more than one output should be shorted at a time and the duration of the short-circuit should not exceed one second.

NOTE 2: I_{CC} is measured by applying 4.5 V to the CLR pin with all other inputs grounded and the outputs open.

switching characteristics, $V_{CC} = 5 \text{ V}, T_A = 25^\circ \text{C}$ (see note 3)

PARAMETER	FROM (INPUT)	TO (OUTPUT)	TEST CONDITIONS	'LS56			'LS57			UNIT
				MIN	TYP	MAX	MIN	TYP	MAX	
f_{max}	CLKA	Q_A	$R_L = 1 \text{ k}\Omega, C_L = 30 \text{ pF}$	15	25		15	25		MHz
f_{max}	CLKB	Q_B, Q_C		15	25		15	25		MHz
t_{PLH}	CLKB	Q_B		8	15		8	15		ns
t_{PHL}				14	25		14	25		ns
t_{PLH}	CLKB	Q_C		18	30		18	30		ns
t_{PHL}				24	35		24	35		ns
t_{PLH}	CLKA	Q_A		12	20		14	25		ns
t_{PHL}				14	25		18	30		ns
t_{PHL}	CLR	Q_A		17	30		17	30		ns
t_{PHL}	CLR	Q_B		17	30		17	30		ns
t_{PHL}	CLR	Q_C		17	30		17	30		ns

† Times measured from CLKB to output Q_C are taken with output Q_B unloaded.

NOTE 3: Load circuits and voltage waveforms are shown in Section 1.

**TEXAS
INSTRUMENTS**

POST OFFICE BOX 655012 • DALLAS, TEXAS 75265

IMPORTANT NOTICE

Texas Instruments (TI) reserves the right to make changes to its products or to discontinue any semiconductor product or service without notice, and advises its customers to obtain the latest version of relevant information to verify, before placing orders, that the information being relied on is current.

TI warrants performance of its semiconductor products and related software to the specifications applicable at the time of sale in accordance with TI's standard warranty. Testing and other quality control techniques are utilized to the extent TI deems necessary to support this warranty. Specific testing of all parameters of each device is not necessarily performed, except those mandated by government requirements.

Certain applications using semiconductor products may involve potential risks of death, personal injury, or severe property or environmental damage ("Critical Applications").

TI SEMICONDUCTOR PRODUCTS ARE NOT DESIGNED, INTENDED, AUTHORIZED, OR WARRANTED TO BE SUITABLE FOR USE IN LIFE-SUPPORT APPLICATIONS, DEVICES OR SYSTEMS OR OTHER CRITICAL APPLICATIONS.

Inclusion of TI products in such applications is understood to be fully at the risk of the customer. Use of TI products in such applications requires the written approval of an appropriate TI officer. Questions concerning potential risk applications should be directed to TI through a local SC sales office.

In order to minimize risks associated with the customer's applications, adequate design and operating safeguards should be provided by the customer to minimize inherent or procedural hazards.

TI assumes no liability for applications assistance, customer product design, software performance, or infringement of patents or services described herein. Nor does TI warrant or represent that any license, either express or implied, is granted under any patent right, copyright, mask work right, or other intellectual property right of TI covering or relating to any combination, machine, or process in which such semiconductor products or services might be or are used.

IMPORTANT NOTICE

Texas Instruments (TI) reserves the right to make changes to its products or to discontinue any semiconductor product or service without notice, and advises its customers to obtain the latest version of relevant information to verify, before placing orders, that the information being relied on is current.

TI warrants performance of its semiconductor products and related software to the specifications applicable at the time of sale in accordance with TI's standard warranty. Testing and other quality control techniques are utilized to the extent TI deems necessary to support this warranty. Specific testing of all parameters of each device is not necessarily performed, except those mandated by government requirements.

Certain applications using semiconductor products may involve potential risks of death, personal injury, or severe property or environmental damage ("Critical Applications").

TI SEMICONDUCTOR PRODUCTS ARE NOT DESIGNED, INTENDED, AUTHORIZED, OR WARRANTED TO BE SUITABLE FOR USE IN LIFE-SUPPORT APPLICATIONS, DEVICES OR SYSTEMS OR OTHER CRITICAL APPLICATIONS.

Inclusion of TI products in such applications is understood to be fully at the risk of the customer. Use of TI products in such applications requires the written approval of an appropriate TI officer. Questions concerning potential risk applications should be directed to TI through a local SC sales office.

In order to minimize risks associated with the customer's applications, adequate design and operating safeguards should be provided by the customer to minimize inherent or procedural hazards.

TI assumes no liability for applications assistance, customer product design, software performance, or infringement of patents or services described herein. Nor does TI warrant or represent that any license, either express or implied, is granted under any patent right, copyright, mask work right, or other intellectual property right of TI covering or relating to any combination, machine, or process in which such semiconductor products or services might be or are used.