

74LCX240

Low-Voltage Octal Buffer/Line Driver with 5V Tolerant Inputs and Outputs

General Description

The LCX240 is an inverting octal buffer and line driver designed to be employed as a memory address driver, clock driver and bus oriented transmitter or receiver. The device is designed for low voltage (3.3V) V_{CC} applications with capability of interfacing to a 5V signal environment.

The LCX240 is fabricated with an advanced CMOS technology to achieve high speed operation while maintaining CMOS low power dissipation.

- Power-down high impedance inputs and outputs
- Supports live insertion/withdrawal
- 2.0V–3.6V V_{CC} supply operation
- ± 24 mA output drive
- Implements patented Quiet Series™ noise/EMI reduction circuitry
- Functionally compatible with the 74 series 240
- Latch-up performance exceeds 500 mA
- ESD performance:
 - Human Body Model > 2000V
 - Machine Model > 200V

Features

- 5V tolerant inputs and outputs
- 6.5 ns t_{PD} max, 10 μA I_{CCQ} max

Logic Symbol

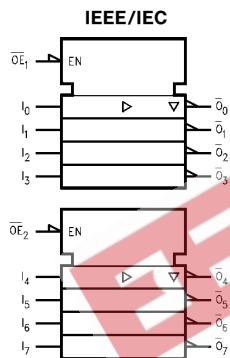

TL/F/11993-1

Connection Diagram

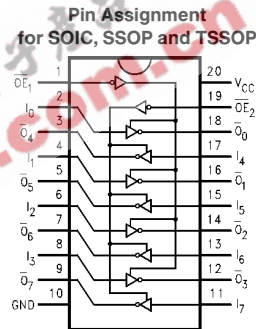

TL/F/11993-2

Pin Names	Description
$\overline{OE}_1, \overline{OE}_2$	TRI-STATE® Output Enable Inputs
I_0-I_7	Inputs
O_0-O_7	Outputs

Truth Tables

Inputs		Outputs (Pins 12, 14, 16, 18)	Inputs		Outputs (Pins 3, 5, 7, 9)
\overline{OE}_1	I_n		\overline{OE}_2	I_n	
L	L	H	L	L	H
L	H	L	L	H	L
H	X	Z	L	X	Z

H = HIGH Voltage Level L = LOW Voltage Level X = Immaterial Z = High Impedance

	SOIC JEDEC	SOIC EIAJ	SSOP Type II	TSSOP
Order Number	74LCX240WM 74LCX240WMX	74LCX240SJ 74LCX240SJX	74LCX240MSA 74LCX240MSAX	74LCX240MTC 74LCX240MTCX
See NS Package Number	M20B	M20D	MSA20	MTC20

TRI-STATE® is a registered trademark of National Semiconductor Corporation.
Quiet Series™ is a trademark of National Semiconductor Corporation.

Absolute Maximum Ratings (Note 1)

If Military/Aerospace specified devices are required, please contact the National Semiconductor Sales Office/Distributors for availability and specifications.

Symbol	Parameter	Value	Conditions	Units
V _{CC}	Supply Voltage	-0.5 to +7.0		V
V _I	DC Input Voltage	-0.5 to +7.0		V
V _O	DC Output Voltage	-0.5 to +7.0	Output in TRI-STATE	V
		-0.5 to V _{CC} + 0.5	Output in High or Low State (Note 2)	V
I _{IK}	DC Input Diode Current	-50	V _I < GND	mA
I _{OK}	DC Output Diode Current	-50	V _O < GND	mA
		+50	V _O > V _{CC}	
I _O	DC Output Source/Sink Current	±50		mA
I _{CC}	DC Supply Current per Supply Pin	±100		mA
I _{GND}	DC Ground Current per Ground Pin	±100		mA
T _{STG}	Storage Temperature	-65 to +150		°C

Note 1: The Absolute Maximum Ratings are those values beyond which the safety of the device cannot be guaranteed. The device should not be operated at these limits. The parametric values defined in the "Electrical Characteristics" table are not guaranteed at the Absolute Maximum Ratings. The "Recommended Operating Conditions" table will define the conditions for actual device operation.

Note 2: I_O Absolute Maximum Rating must be observed.

Recommended Operating Conditions

Symbol	Parameter	Min	Max	Units	
V _{CC}	Supply Voltage	Operating	2.0	3.6	V
		Data Retention	1.5	3.6	
V _I	Input Voltage	0	5.5	V	
V _O	Output Voltage	HIGH or LOW State	0	V _{CC}	V
		TRI-STATE	0	5.5	
I _{OH} /I _{OL}	Output Current			±24 ±12	mA
T _A	Free-Air Operating Temperature	-40	85	°C	
Δt/ΔV	Input Edge Rate, V _{IN} = 0.8V-2.0V, V _{CC} = 3.0V	0	10	ns/V	

DC Electrical Characteristics

Symbol	Parameter	Conditions	V _{CC} (V)	T _A = -40°C to +85°C		Units
				Min	Max	
V _{IH}	HIGH Level Input Voltage		2.7-3.6	2.0		V
V _{IL}	LOW Level Input Voltage		2.7-3.6		0.8	V
V _{OH}	HIGH Level Output Voltage	I _{OH} = -100 μA	2.7-3.6	V _{CC} - 0.2		V
		I _{OH} = -12 mA	2.7	2.2		V
		I _{OH} = -18 mA	3.0	2.4		V
		I _{OH} = -24 mA	3.0	2.2		V
V _{OL}	LOW Level Output Voltage	I _{OL} = 100 μA	2.7-3.6		0.2	V
		I _{OL} = 12 mA	2.7		0.4	V
		I _{OL} = 16 mA	3.0		0.4	V
		I _{OL} = 24 mA	3.0		0.55	V
I _I	Input Leakage Current	0 ≤ V _I ≤ 5.5V	2.7-3.6		±5.0	μA
I _{OZ}	TRI-STATE Output Leakage	0 ≤ V _O ≤ 5.5V V _I = V _{IH} or V _{IL}	2.7-3.6		±5.0	μA
I _{OFF}	Power-Off Leakage Current	V _I or V _O = 5.5V	0		10	μA
I _{CC}	Quiescent Supply Current	V _I = V _{CC} or GND	2.7-3.6		10	μA
		3.6V ≤ V _I , V _O ≤ 5.5V	2.7-3.6		±10	μA
ΔI _{CC}	Increase in I _{CC} per Input	V _{IH} = V _{CC} - 0.6V	2.7-3.6		500	μA

AC Electrical Characteristics						
Symbol	Parameter	$T_A = -40^{\circ}\text{C to } +85^{\circ}\text{C}$				Units
		$V_{CC} = 3.3\text{V} \pm 0.3\text{V}$		$V_{CC} = 2.7\text{V}$		
		Min	Max	Min	Max	
t_{PHL} t_{PLH}	Propagation Delay Data to Output	1.5 1.5	6.5 6.5	1.5 1.5	7.5 7.5	ns
t_{PZL} t_{PZH}	Output Enable Time	1.5 1.5	8.0 8.0	1.5 1.5	9.0 9.0	ns
t_{PLZ} t_{PHZ}	Output Disable Time	1.5 1.5	7.0 7.0	1.5 1.5	8.0 8.0	ns
t_{OSHL} t_{OSLH}	Output to Output Skew (Note 1)		1.0 1.0			ns

Note 1: Skew is defined as the absolute value of the difference between the actual propagation delay for any two separate outputs of the same device. The specification applies to any outputs switching in the same direction, either HIGH to LOW (t_{OSHL}) or LOW to HIGH (t_{OSLH}).

Dynamic Switching Characteristics					
Symbol	Parameter	Conditions	V_{CC} (V)	$T_A = 25^{\circ}\text{C}$	Units
				Typical	
V_{OLP}	Quiet Output Dynamic Peak V_{OL}	$C_L = 50\text{ pF}, V_{IH} = 3.3\text{V}, V_{IL} = 0\text{V}$	3.3	0.8	V
V_{OLV}	Quiet Output Dynamic Valley V_{OL}	$C_L = 50\text{ pF}, V_{IH} = 3.3\text{V}, V_{IL} = 0\text{V}$	3.3	-0.8	V

Capacitance				
Symbol	Parameter	Conditions	Typical	Units
C_{IN}	Input Capacitance	$V_{CC} = \text{Open}, V_I = 0\text{V or } V_{CC}$	7	pF
C_{OUT}	Output Capacitance	$V_{CC} = 3.3\text{V}, V_I = 0\text{V or } V_{CC}$	8	pF
C_{PD}	Power Dissipation Capacitance	$V_{CC} = 3.3\text{V}, V_I = 0\text{V or } V_{CC}, F = 10\text{ MHz}$	25	pF

74LCX240 Ordering Information

The device number is used to form part of a simplified purchasing code where the package type and temperature range are defined as follows:

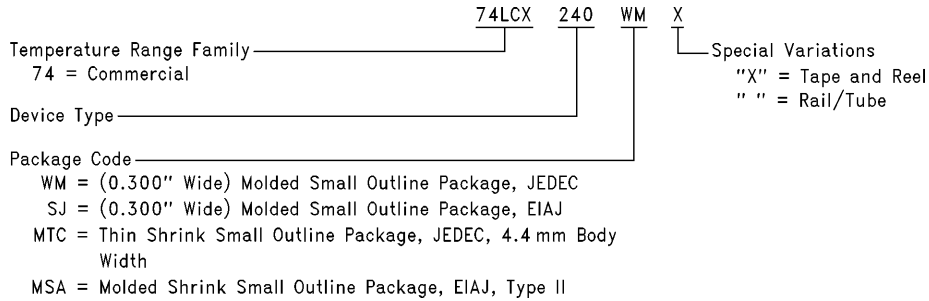

TL/F/11993-3

Physical Dimensions inches (millimeters) unless otherwise noted

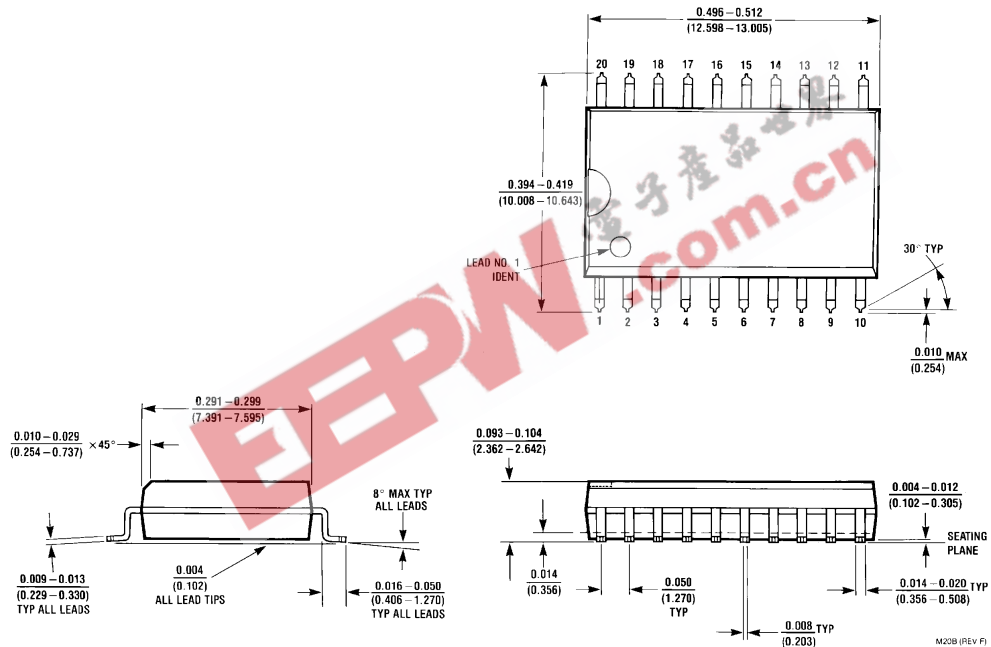

20-Lead Small Outline Integrated Circuit
Order Number 74LCX240WM or 74LCX240WMX
NS Package Number M20B

Physical Dimensions inches (millimeters) unless otherwise noted (Continued)

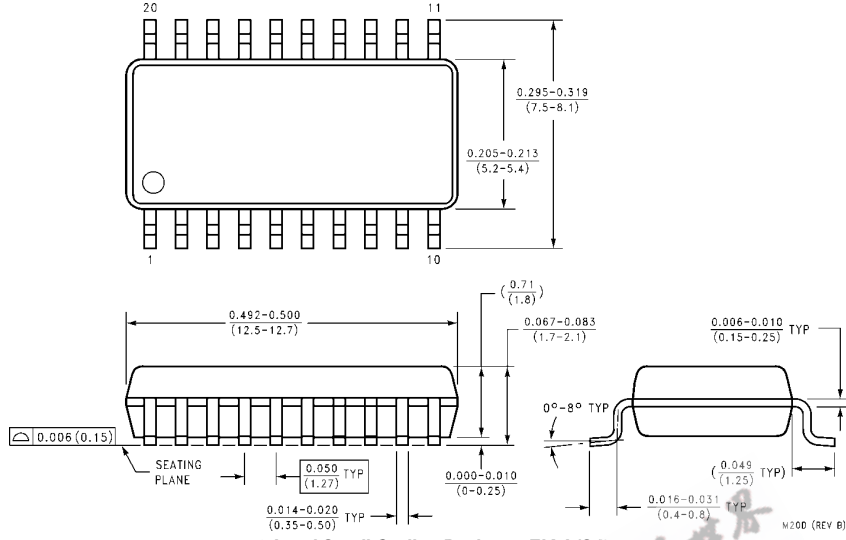

20-Lead Small Outline Package, EIAJ (SJ)
Order Number 74LCX240SJ or 74LCX240SJX
NS Package Number M20D

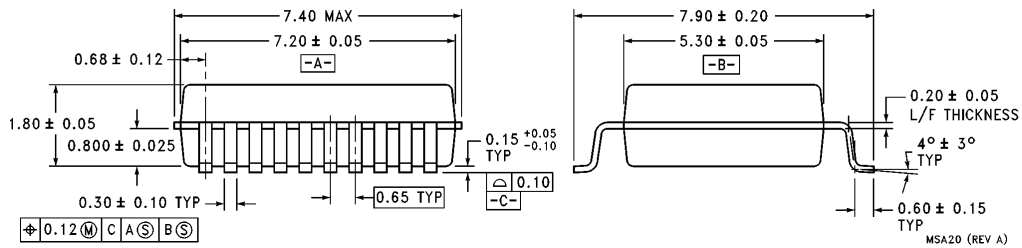
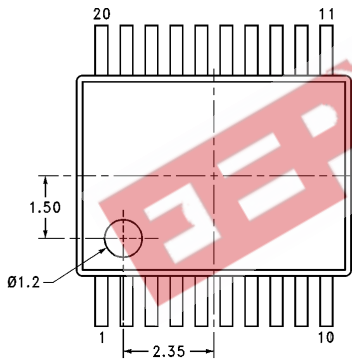

All dimensions are in millimeters.

20-Lead Molded Shrink Small Outline Package, EIAJ, Type II
Order Number 74LCX240MSA or 74LCX240MSAX
NS Package Number MSA20

Physical Dimensions All dimensions are in millimeters (Continued)

DIMENSIONS METRIC ONLY

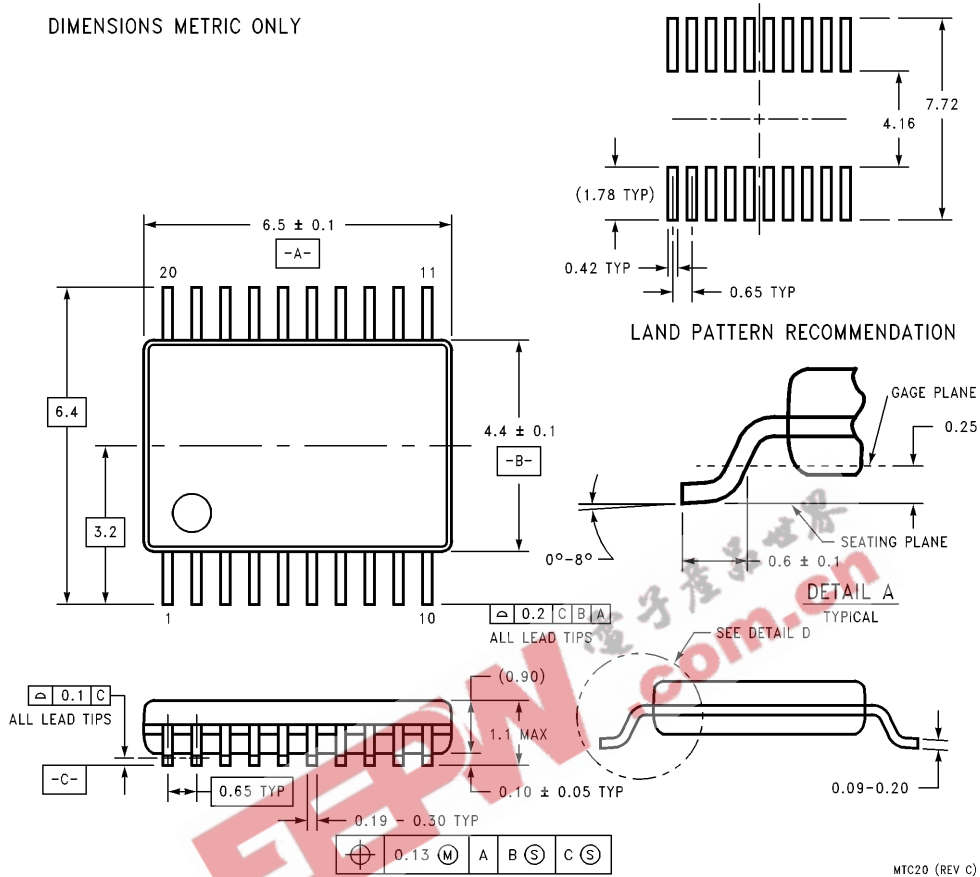

20-Lead Thin Shrink Small Outline Package, JEDEC
Order Number 74LCX240MTC or 74LCX240MTCX
NS Package Number MTC20

MTC20 (REV C)

LIFE SUPPORT POLICY

NATIONAL'S PRODUCTS ARE NOT AUTHORIZED FOR USE AS CRITICAL COMPONENTS IN LIFE SUPPORT DEVICES OR SYSTEMS WITHOUT THE EXPRESS WRITTEN APPROVAL OF THE PRESIDENT OF NATIONAL SEMICONDUCTOR CORPORATION. As used herein:

1. Life support devices or systems are devices or systems which, (a) are intended for surgical implant into the body, or (b) support or sustain life, and whose failure to perform, when properly used in accordance with instructions for use provided in the labeling, can be reasonably expected to result in a significant injury to the user.
2. A critical component is any component of a life support device or system whose failure to perform can be reasonably expected to cause the failure of the life support device or system, or to affect its safety or effectiveness.



National Semiconductor Corporation
Americas
 Tel: 1(800) 272-9959
 Fax: 1(800) 737-7018
 Email: support@nsc.com

National Semiconductor Europe
 Fax: +49 (0) 180-530 85 86
 Email: europe.support@nsc.com
 Deutsch Tel: +49 (0) 180-530 85 85
 English Tel: +49 (0) 180-532 78 32
 Français Tel: +49 (0) 180-532 93 58
 Italiano Tel: +49 (0) 180-534 16 80

National Semiconductor Southeast Asia
 Fax: (852) 2376 3901
 Email: sea.support@nsc.com

National Semiconductor Japan Ltd.
 Tel: 81-3-5620-7561
 Fax: 81-3-5620-6179

<http://www.national.com>