

## 54F/74F646 • 74F646B • 54F/74F648 Octal Transceiver/Register with TRI-STATE® Outputs

### General Description

These devices consist of bus transceiver circuits with TRI-STATE, D-type flip-flops, and control circuitry arranged for multiplexed transmission of data directly from the input bus or from the internal registers. Data on the A or B bus will be clocked into the registers as the appropriate clock pin goes to a high logic level. Control  $\bar{G}$  and direction pins are provided to control the transceiver function. In the transceiver mode, data present at the high impedance port may be stored in either the A or the B register or in both. The select controls can multiplex stored and real-time (transparent mode) data. The direction control determines which bus will receive data when the enable control  $\bar{G}$  is Active LOW. In the isolation mode (control  $\bar{G}$  HIGH), A data may be stored in the B register and/or B data may be stored in the A register.

### Features

- Independent registers for A and B buses
- Multiplexed real-time and stored data
- 'F648 has inverting data paths
- 'F646/'F646B have non-inverting data paths
- 'F646B is a faster version of the 'F646
- TRI-STATE outputs
- 300 mil slim DIP
- Guaranteed 4000V minimum ESD protection

Commercial	Military	Package Number	Package Description
74F646SPC		N24C	24-Lead (0.300" Wide) Molded Dual-In-Line
	54F646DM (Note 2)	J24F	24-Lead (0.300" Wide) Ceramic Dual-In-Line
74F646SC (Note 1)		M24B	24-Lead (0.300" Wide) Molded Small Outline, JEDEC
74F646MSA (Note 1)		MSA24	24-Lead Molded Shrink Small Outline, EIAJ, Type II
	54F646FM (Note 2)	W24C	24-Lead Cerpack
	54F646LM (Note 2)	E28A	28-Lead Ceramic Leadless Chip Carrier, Type C
74F646BSPC		N24C	24-Lead (0.300" Wide) Molded Dual-In-Line
74F646BSC (Note 1)		M24B	24-Lead (0.300" Wide) Molded Small Outline, JEDEC
74F648SPC		N24C	24-Lead (0.300" Wide) Molded Dual-In-Line
	54F648SDM (Note 2)	J24F	24-Lead (0.300" Wide) Ceramic Dual-In-Line
74F648SC (Note 1)		M24B	24-Lead (0.300" Wide) Molded Small Outline, JEDEC
	54F648FM (Note 2)	W24C	24-Lead Cerpack
	54F648LM (Note 2)	E28A	24-Lead Ceramic Leadless Chip Carrier, Type C

**Note 1:** Devices also available in 13" reel. Use suffix = SCX.

**Note 2:** Military grade device with environmental and burn-in processing. Use suffix = DMQB, FMQB and LMQB.

### Logic Symbols

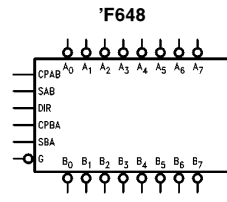
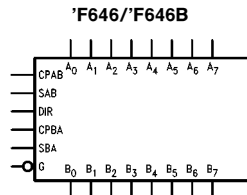

TRI-STATE® is a registered trademark of National Semiconductor Corporation.

## Logic Symbols (Continued)

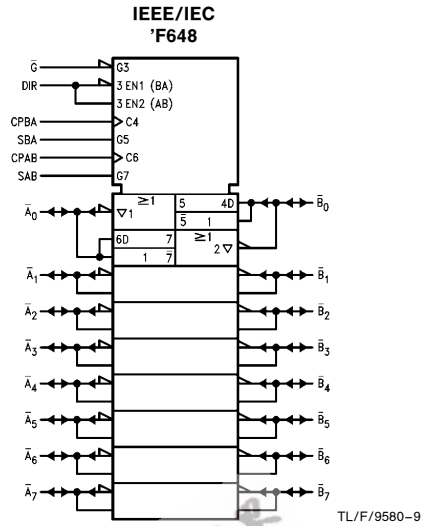
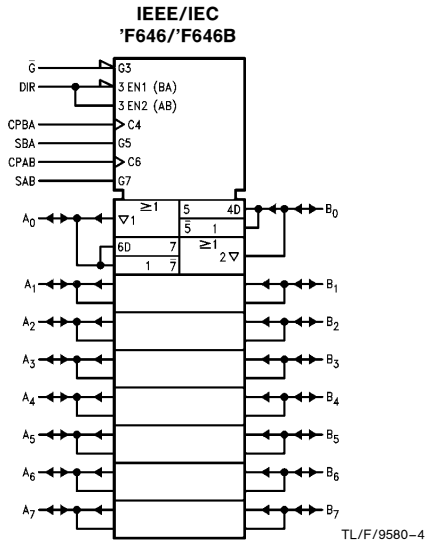

## Connection Diagrams

**Pin Assignment  
for DIP, SOIC and Flatpak  
'F646/'F646B**

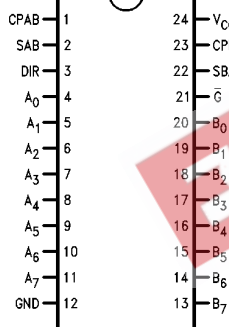

**Pin Assignment  
for DIP, SOIC and Flatpak  
'F648**

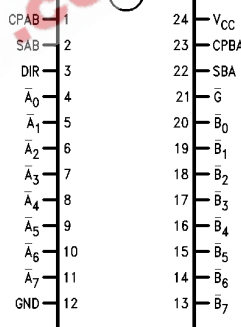

**Pin Assignment  
for LCC  
'F646/'F646B**

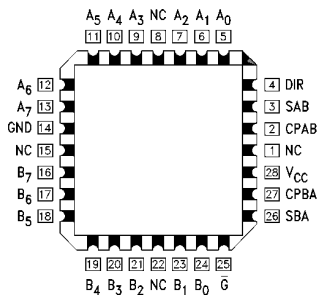

**Pin Assignment  
for LCC  
'F648**

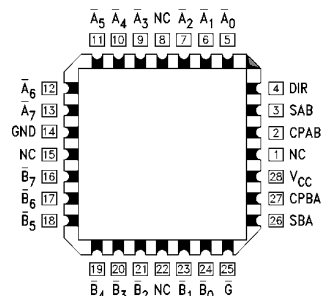

## Unit Loading/Fan Out

Pin Names	Description	54F/74F	
		U.L. HIGH/LOW	Input $I_{IH}/I_{IL}$ Output $I_{OH}/I_{OL}$
A <sub>0</sub> –A <sub>7</sub>	Data Register A Inputs/ TRI-STATE Outputs	3.5/1.083 600/106.6 (80)	70 $\mu$ A/ –650 $\mu$ A –12 mA/64 mA (48 mA)
B <sub>0</sub> –B <sub>7</sub>	Data Register B Inputs/ TRI-STATE Outputs	3.5/1.083 600/106.6 (80)	70 $\mu$ A/ –650 $\mu$ A –12 mA/64 mA (48 mA)
CPAB, CPBA	Clock Pulse Inputs	1.0/1.0	20 $\mu$ A/ –0.6 mA
SAB, SBA	Select Inputs	1.0/1.0	20 $\mu$ A/ –0.6 mA
$\bar{G}$	Output Enable Input	1.0/1.0	20 $\mu$ A/ –0.6 mA
DIR	Direction Control Input	1.0/1.0	20 $\mu$ A/ –0.6 mA

Function Table

Inputs						Data I/O*		Function
$\bar{G}$	DIR	CPAB	CPBA	SAB	SBA	A <sub>0</sub> –A <sub>7</sub>	B <sub>0</sub> –B <sub>7</sub>	
H	X	H or L	H or L	X	X	Input	Input	Isolation
H	X	↗	X	X	X			Clock A <sub>n</sub> Data into A Register
H	X	X	↗	X	X			Clock B <sub>n</sub> Data into B Register
L	H	X	X	L	X	Input	Output	A <sub>n</sub> to B <sub>n</sub> —Real Time (Transparent Mode)
L	H	↗	X	L	X			Clock A <sub>n</sub> Data into A Register
L	H	H or L	X	H	X			A Register to B <sub>n</sub> (Stored Mode)
L	H	↗	X	H	X			Clock A <sub>n</sub> Data into A Register and Output to B <sub>n</sub>
L	L	X	X	X	L	Output	Input	B <sub>n</sub> to A <sub>n</sub> —Real Time (Transparent Mode)
L	L	X	↗	X	L			Clock B <sub>n</sub> Data into B Register
L	L	X	H or L	X	H			B Register to A <sub>n</sub> (Stored Mode)
L	L	X	↗	X	H			Clock B <sub>n</sub> Data into B Register and Output to A <sub>n</sub>

\*The data output functions may be enabled or disabled by various signals at the  $\bar{G}$  and DIR inputs. Data input functions are always enabled; i.e., data at the bus pins will be stored on every LOW-to-HIGH transition of the clock inputs.

H = HIGH Voltage Level

L = LOW Voltage Level

X = Irrelevant

↗ = LOW-to-HIGH Transition

**Logic Diagrams** (Continued)

'F646/'F646B

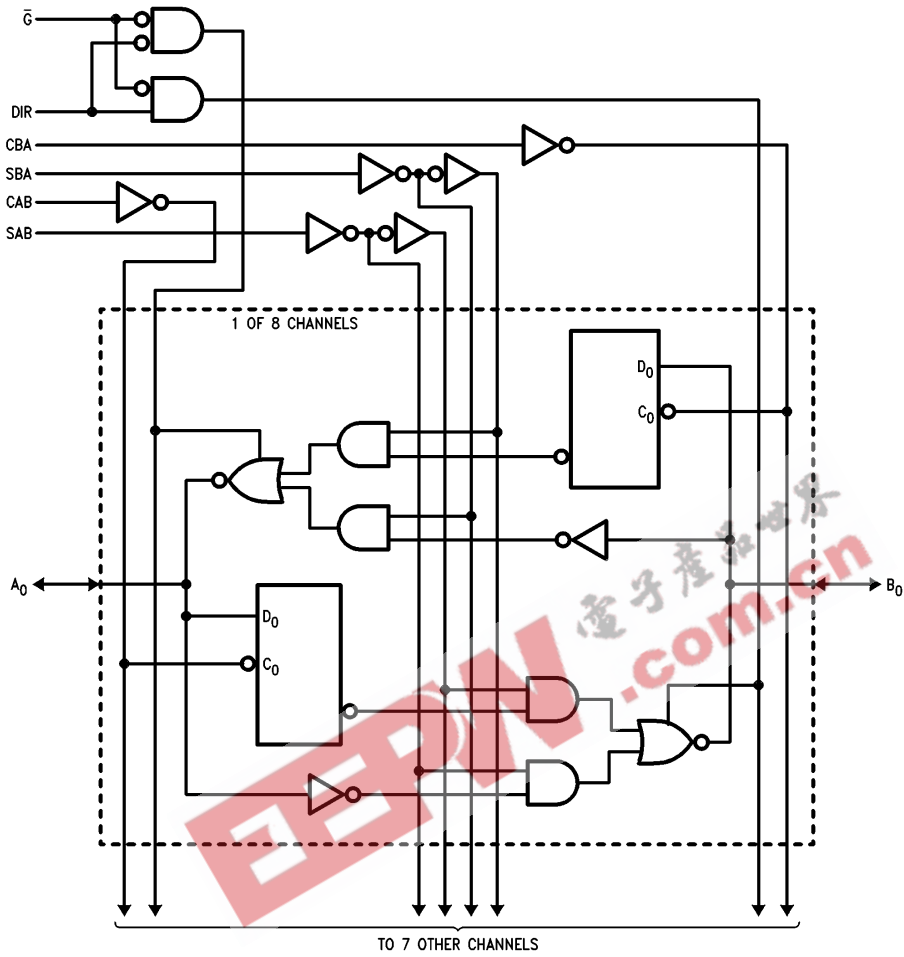

TL/F/9580-5

Please note that this diagram is provided only for the understanding of logic operations and should not be used to estimate propagation delays.

**Logic Diagrams** (Continued)

'F648

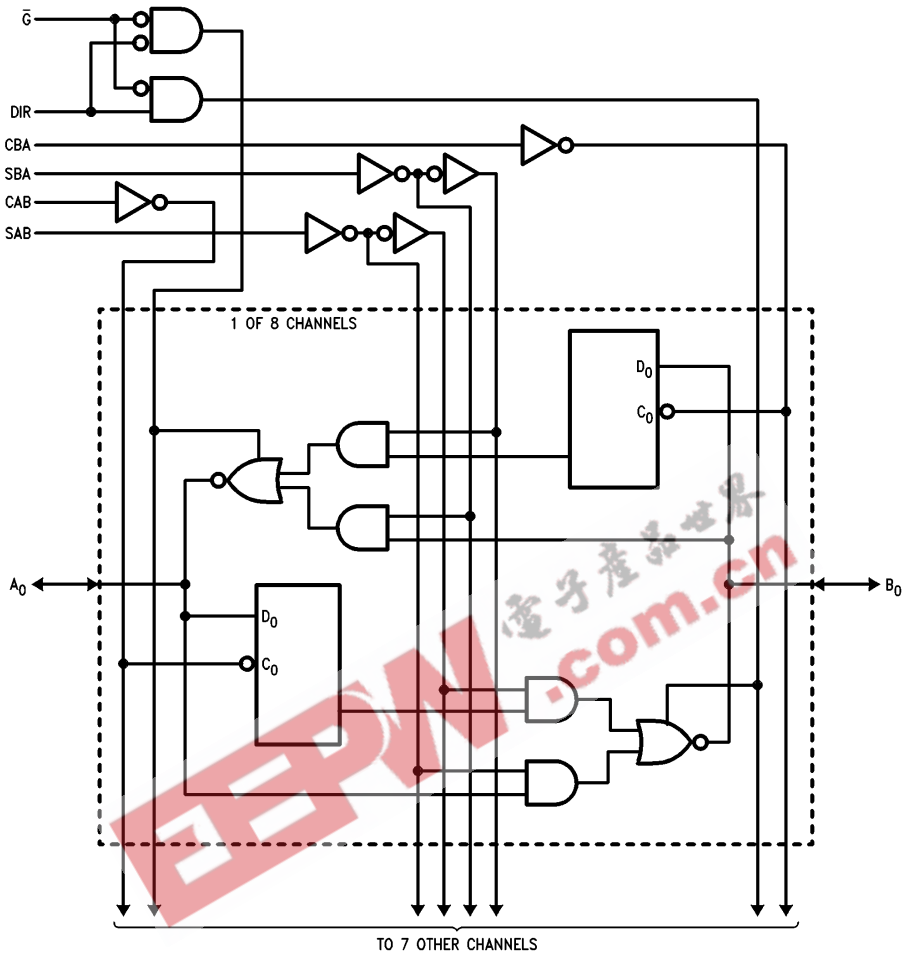

TL/F/9580-6

Please note that this diagram is provided only for the understanding of logic operations and should not be used to estimate propagation delays.

## Absolute Maximum Ratings (Note 1)

If Military/Aerospace specified devices are required, please contact the National Semiconductor Sales Office/Distributors for availability and specifications.

Storage Temperature	-65°C to +150°C
Ambient Temperature under Bias	-55°C to +125°C
Junction Temperature under Bias	-55°C to +175°C
Plastic	-55°C to +150°C
V <sub>CC</sub> Pin Potential to Ground Pin	-0.5V to +7.0V
Input Voltage (Note 2)	-0.5V to +7.0V
Input Current (Note 2)	-30 mA to +5.0 mA
Voltage Applied to Output in HIGH State (with V <sub>CC</sub> = 0V)	
Standard Output	-0.5V to V <sub>CC</sub>
TRI-STATE Output	-0.5V to +5.5V
Current Applied to Output in LOW State (Max)	twice the rated I <sub>OL</sub> (mA)
ESD Last Passing Voltage (Min)	4000V

**Note 1:** Absolute maximum ratings are values beyond which the device may be damaged or have its useful life impaired. Functional operation under these conditions is not implied.

**Note 2:** Either voltage limit or current limit is sufficient to protect inputs.

## Recommended Operating Conditions

Free Air Ambient Temperature	
Military	-55°C to +125°C
Commercial	0°C to +70°C
Supply Voltage	
Military	+4.5V to +5.5V
Commercial	+4.5V to +5.5V

## DC Electrical Characteristics

Symbol	Parameter	54F/74F			Units	V <sub>CC</sub>	Conditions
		Min	Typ	Max			
V <sub>IH</sub>	Input HIGH Voltage	2.0			V		Recognized as a HIGH Signal
V <sub>IL</sub>	Input LOW Voltage	0.8			V		Recognized as a LOW Signal
V <sub>CD</sub>	Input Clamp Diode Voltage	-1.2			V	Min	I <sub>IN</sub> = -18 mA (Non I/O Pins)
V <sub>OH</sub>	Output HIGH Voltage	54F 10% V <sub>CC</sub> 74F 10% V <sub>CC</sub>	2.0 2.0		V	Min	I <sub>OH</sub> = -12 mA (A <sub>n</sub> , B <sub>n</sub> ) I <sub>OH</sub> = -15 mA (A <sub>n</sub> , B <sub>n</sub> )
V <sub>OL</sub>	Output LOW Voltage	54F 10% V <sub>CC</sub> 74F 10% V <sub>CC</sub>	0.55 0.55		V	Min	I <sub>OL</sub> = 48 mA (A <sub>n</sub> , B <sub>n</sub> ) I <sub>OL</sub> = 64 mA (A <sub>n</sub> , B <sub>n</sub> )
I <sub>IH</sub>	Input HIGH Current	54F 74F	20.0 5.0		μA	Max	V <sub>IN</sub> = 2.7V (Non I/O Pins)
I <sub>BVI</sub>	Input HIGH Current Breakdown Test	54F 74F	100 7.0		μA	Max	V <sub>IN</sub> = 7.0V (Non I/O Pins)
I <sub>BVIT</sub>	Input HIGH Current Breakdown (I/O)	54F 74F	1.0 0.5		mA	Max	V <sub>IN</sub> = 5.5V (A <sub>n</sub> , B <sub>n</sub> )
I <sub>CEX</sub>	Output HIGH Leakage Current	54F 74F	250 50		μA	Max	V <sub>OUT</sub> = V <sub>CC</sub>
V <sub>ID</sub>	Input Leakage Test	74F	4.75		V	0.0	I <sub>ID</sub> = 1.9 μA All Other Pins Grounded
I <sub>OD</sub>	Output Leakage Circuit Current	74F	3.75		μA	0.0	V <sub>IOD</sub> = 150 mV All Other Pins Grounded
I <sub>IL</sub>	Input LOW Current		-0.6		mA	Max	V <sub>IN</sub> = 0.5V (Non I/O Pins)
I <sub>IH</sub> + I <sub>OZH</sub>	Output Leakage Current		70		μA	Max	V <sub>OUT</sub> = 2.7V (A <sub>n</sub> , B <sub>n</sub> )
I <sub>IL</sub> + I <sub>OZL</sub>	Output Leakage Current		-650		μA	Max	V <sub>OUT</sub> = 0.5V (A <sub>n</sub> , B <sub>n</sub> )
I <sub>OS</sub>	Output Short-Circuit Current		-100	-225	mA	Max	V <sub>OUT</sub> = 0V
I <sub>ZZ</sub>	Bus Drainage Test		500		μA	0.0V	V <sub>OUT</sub> = 5.25V
I <sub>CCH</sub>	Power Supply Current		135		mA	Max	V <sub>O</sub> = HIGH
I <sub>CCL</sub>	Power Supply Current		150		mA	Max	V <sub>O</sub> = LOW
I <sub>CCZ</sub>	Power Supply Current		150		mA	Max	V <sub>O</sub> = HIGH Z

<b>'F646/'F648</b>								
<b>AC Electrical Characteristics</b>								
Symbol	Parameter	74F		54F		74F		Units
		T <sub>A</sub> = +25°C V <sub>CC</sub> = +5.0V C <sub>L</sub> = 50 pF		T <sub>A</sub> , V <sub>CC</sub> = Mil C <sub>L</sub> = 50 pF		T <sub>A</sub> , V <sub>CC</sub> = Com C <sub>L</sub> = 50 pF		
		Min	Max	Min	Max	Min	Max	
f <sub>max</sub>	Maximum Clock Frequency	90		75		90		MHz
t <sub>PLH</sub> t <sub>PHL</sub>	Propagation Delay Clock to Bus	2.0 2.0	7.0 8.0	2.0 2.0	8.5 9.5	2.0 2.0	8.0 9.0	ns
t <sub>PLH</sub> t <sub>PHL</sub>	Propagation Delay Bus to Bus ('F646)	1.0 1.0	7.0 6.5	1.0 1.0	8.0 8.0	1.0 1.0	7.5 7.0	ns
t <sub>PLH</sub> t <sub>PHL</sub>	Propagation Delay Bus to Bus ('F648)	2.0 1.0	8.5 7.5	1.0 1.0	10.0 9.0	2.0 1.0	9.0 8.0	ns
t <sub>PLH</sub> t <sub>PHL</sub>	Propagation Delay SBA or SAB to A or B	2.0 2.0	8.5 8.0	2.0 2.0	11.0 10.0	2.0 2.0	9.5 9.0	ns
t <sub>PZH</sub> t <sub>PZL</sub>	Enable Time OE to A or B	2.0 2.0	8.5 12.0	2.0 2.0	10.0 13.5	2.0 2.0	9.0 12.5	ns
t <sub>PHZ</sub> t <sub>PLZ</sub>	Disable Time OE to A or B	1.0 2.0	7.5 9.0	1.0 2.0	9.0 11.0	1.0 2.0	8.5 9.5	ns
t <sub>PZH</sub> t <sub>PZL</sub>	Enable Time DIR to A or B	2.0 2.0	14.0 13.0	2.0 2.0	16.0 15.0	2.0 2.0	15.0 14.0	ns
t <sub>PHZ</sub> t <sub>PLZ</sub>	Disable Time DIR to A or B	1.0 2.0	9.0 11.0	1.0 2.0	10.0 12.0	1.0 2.0	9.5 11.5	ns

<b>'F646/'F648</b>								
<b>AC Operating Requirements</b>								
Symbol	Parameter	74F		54F		74F		Units
		T <sub>A</sub> = +25°C V <sub>CC</sub> = +5.0V		T <sub>A</sub> , V <sub>CC</sub> = Mil		T <sub>A</sub> , V <sub>CC</sub> = Com		
		Min	Max	Min	Max	Min	Max	
t <sub>s</sub> (H) t <sub>s</sub> (L)	Setup Time, HIGH or LOW Bus to Clock	5.0 5.0		5.0 5.0		5.0 5.0		ns
t <sub>h</sub> (H) t <sub>h</sub> (L)	Hold Time, HIGH or LOW Bus to Clock	2.0 2.0		2.5 2.5		2.0 2.0		ns
t <sub>w</sub> (H) t <sub>w</sub> (L)	Clock Pulse Width HIGH or LOW	5.0 5.0		5.0 5.0		5.0 5.0		ns

## 'F646B

### AC Electrical Characteristics

Symbol	Parameter	74F		54F		74F		Units
		$T_A = +25^\circ\text{C}$ $V_{CC} = +5.0\text{V}$ $C_L = 50\text{ pF}$		$T_A, V_{CC} = \text{Mil}$ $C_L = 50\text{ pF}$		$T_A, V_{CC} = \text{Com}$ $C_L = 50\text{ pF}$		
		Min	Max	Min	Max	Min	Max	
$f_{\text{max}}$	Maximum Clock Frequency	165				150		MHz
$t_{\text{PLH}}$ $t_{\text{PHL}}$	Propagation Delay Clock to Bus	2.5 3.0	7.0 7.5			2.5 3.0	8.0 8.0	ns
$t_{\text{PLH}}$ $t_{\text{PHL}}$	Propagation Delay Bus to Bus	2.0 2.0	6.0 6.0			2.0 2.0	7.0 7.0	ns
$t_{\text{PLH}}$ $t_{\text{PHL}}$	Propagation Delay SBA or SAB to A or B	2.5 2.5	7.5 7.5			2.5 2.5	8.5 8.5	ns
$t_{\text{PZH}}$ $t_{\text{PZL}}$	Enable Time $\overline{\text{OE}}$ to A or B	2.5 2.5	6.5 9.0			2.5 2.5	8.0 10.0	ns
$t_{\text{PHZ}}$ $t_{\text{PLZ}}$	Disable Time $\overline{\text{OE}}$ to A or B	1.5 2.0	6.5 7.0			1.5 2.0	7.5 8.5	ns
$t_{\text{PZH}}$ $t_{\text{PZL}}$	Enable Time DIR to A or B	2.0 3.0	7.0 9.5			2.0 3.0	8.5 10.0	ns
$t_{\text{PHZ}}$ $t_{\text{PLZ}}$	Disable Time DIR to A or B	1.5 2.5	7.5 8.5			1.5 2.5	8.5 9.5	ns

## 'F646B

### AC Operating Requirements

Symbol	Parameter	74F		54F		74F		Units
		$T_A = +25^\circ\text{C}$ $V_{CC} = +5.0\text{V}$		$T_A, V_{CC} = \text{Mil}$		$T_A, V_{CC} = \text{Com}$		
		Min	Max	Min	Max	Min	Max	
$t_s(\text{H})$ $t_s(\text{L})$	Setup Time, HIGH or LOW Bus to Clock	5.0 5.0				4.0 4.0		ns
$t_h(\text{H})$ $t_h(\text{L})$	Hold Time, HIGH or LOW Bus to Clock	1.5 1.5				1.5 1.5		ns
$t_w(\text{H})$ $t_w(\text{L})$	Clock Pulse Width HIGH or LOW	5.0 5.0				5.0 5.0		ns

### Ordering Information

The device number is used to form part of a simplified purchasing code where the package type and temperature range are defined as follows:

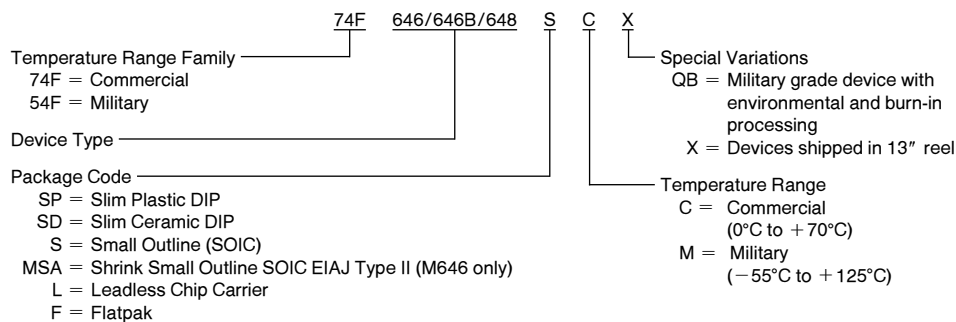





**Physical Dimensions** inches (millimeters) (Continued)

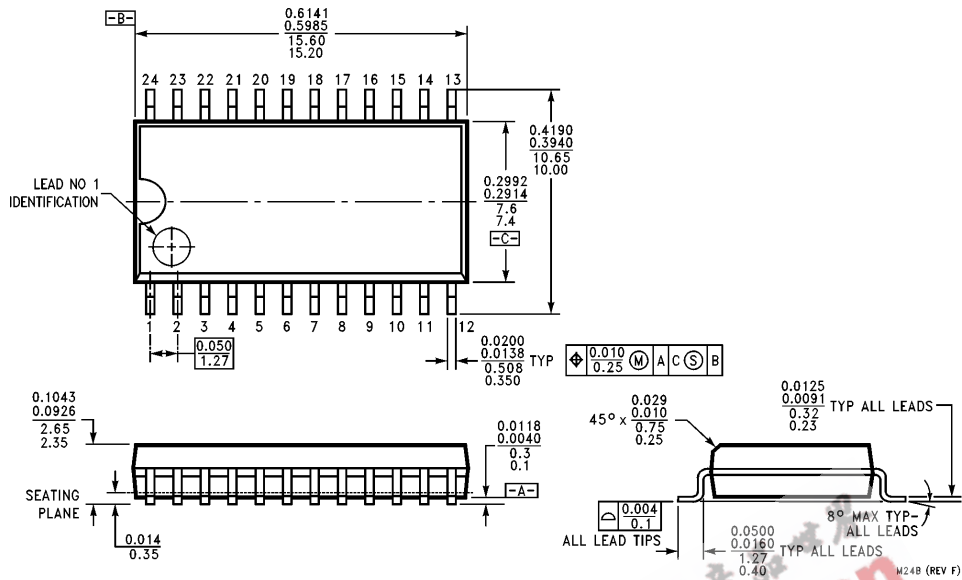

24-Lead (0.300" Wide) Molded Small Outline Package, JEDEC (S)  
NS Package Number M24B

EEPW.com.cn



**Physical Dimensions** inches (millimeters) (Continued)

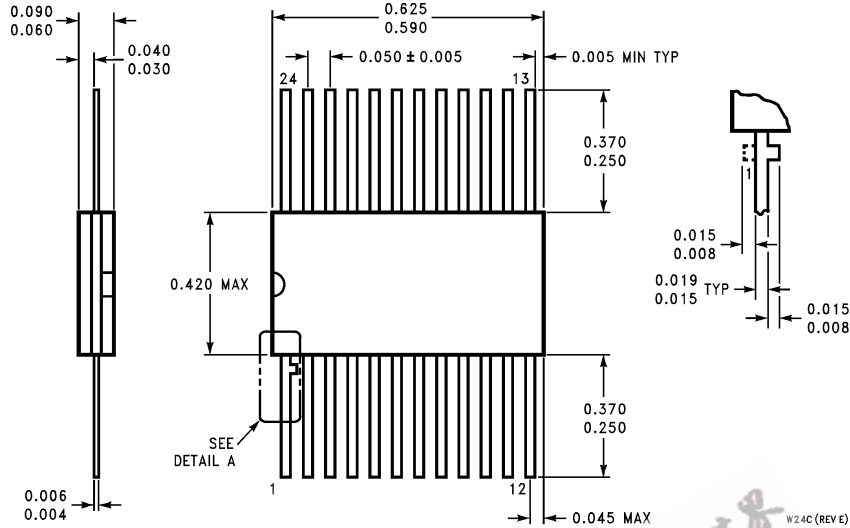

**24-Lead Cerpack  
NS Package Number W24C**



**LIFE SUPPORT POLICY**

NATIONAL'S PRODUCTS ARE NOT AUTHORIZED FOR USE AS CRITICAL COMPONENTS IN LIFE SUPPORT DEVICES OR SYSTEMS WITHOUT THE EXPRESS WRITTEN APPROVAL OF THE PRESIDENT OF NATIONAL SEMICONDUCTOR CORPORATION. As used herein:

1. Life support devices or systems are devices or systems which, (a) are intended for surgical implant into the body, or (b) support or sustain life, and whose failure to perform, when properly used in accordance with instructions for use provided in the labeling, can be reasonably expected to result in a significant injury to the user.
2. A critical component is any component of a life support device or system whose failure to perform can be reasonably expected to cause the failure of the life support device or system, or to affect its safety or effectiveness.



**National Semiconductor Corporation**  
2900 Semiconductor Drive  
P.O. Box 58090  
Santa Clara, CA 95052-8090  
Tel: 1 (800) 272-9959  
TWX: (910) 339-9240

**National Semiconductor GmbH**  
Livry-Gargan-Str. 10  
D-82256 Fürstenfeldbruck  
Germany  
Tel: (81-41) 35-0  
Telex: 527649  
Fax: (81-41) 35-1

**National Semiconductor Japan Ltd.**  
Sumitomo Chemical  
Engineering Center  
Bldg. 7F  
1-7-1, Nakase, Mihama-Ku  
Chiba-City,  
Chiba Prefecture 261  
Tel: (043) 299-2300  
Fax: (043) 299-2500

**National Semiconductor Hong Kong Ltd.**  
13th Floor, Straight Block,  
Ocean Centre, 5 Canton Rd.  
Tsimshatsui, Kowloon  
Hong Kong  
Tel: (852) 2737-1600  
Fax: (852) 2736-9960

**National Semiconductores Do Brazil Ltda.**  
Rue Deputado Lacorda Franco  
120-3A  
Sao Paulo-SP  
Brazil 05418-000  
Tel: (55-11) 212-5066  
Telex: 391-1131931 NSBR BR  
Fax: (55-11) 212-1181

**National Semiconductor (Australia) Pty, Ltd.**  
Building 16  
Business Park Drive  
Monash Business Park  
Nottingham, Melbourne  
Victoria 3168 Australia  
Tel: (3) 558-9899  
Fax: (3) 558-9998

National does not assume any responsibility for use of any circuitry described, no circuit patent licenses are implied and National reserves the right at any time without notice to change said circuitry and specifications.