

## FEATURES

- Wide Variety of Input Types
- Standard Package and Pin-out
- Single 5V Power Supply
- 12-Bit Resolution
- Optical Isolation from Input to Output
- Cold Junction Temperature Compensated Connector Included
- Intermix With G5 Digital Modules on the Same Rack
- Meets the Requirements of IEEE 472
- UL, CSA, CE Certified (OpenLine only)

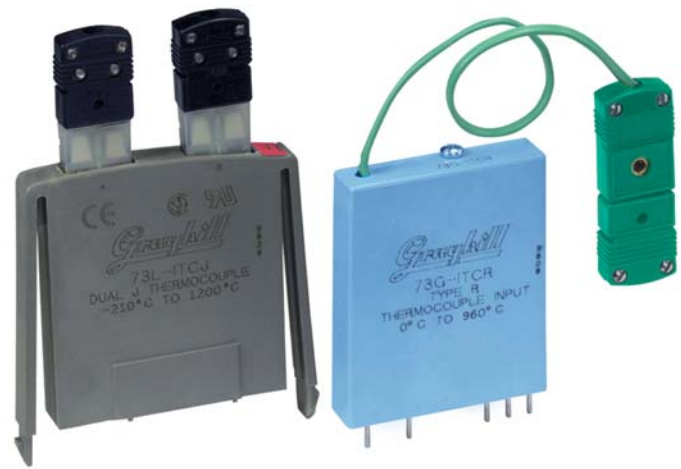

73L-IT

73G-IT

## CIRCUITRY

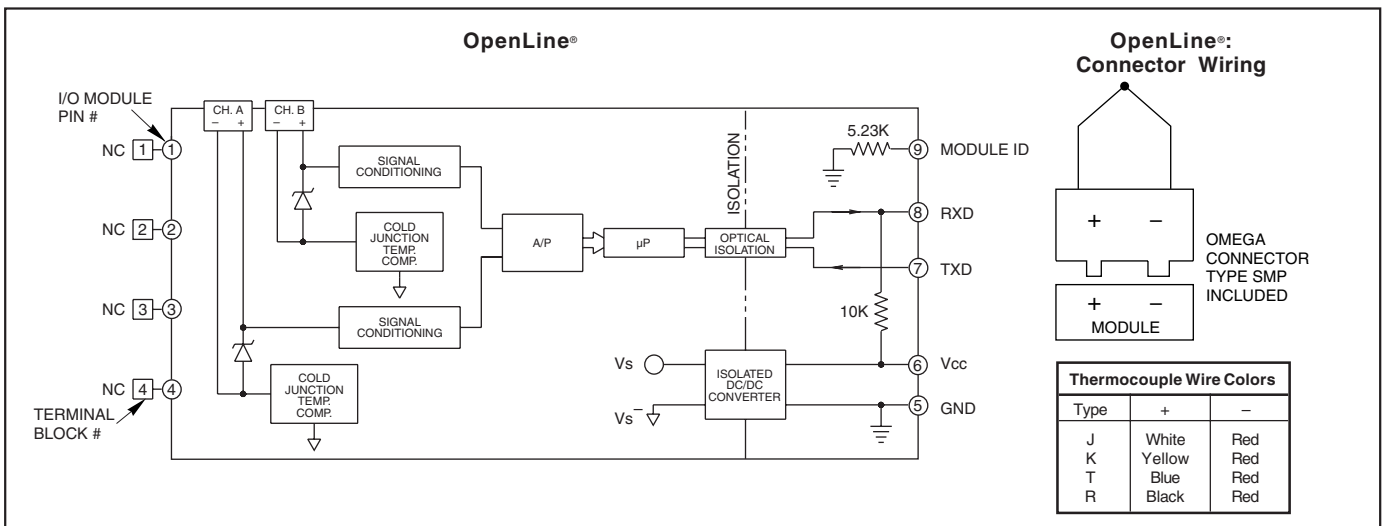
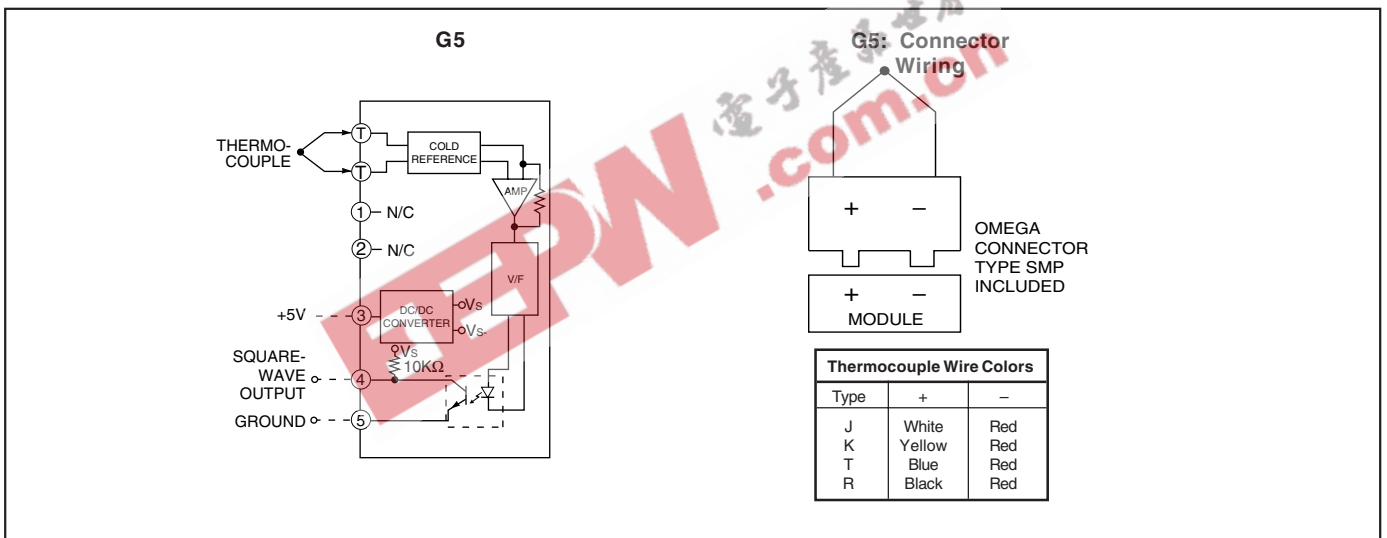

**SPECIFICATIONS: By Part Number**

Type/Function		Grayhill Part Number			
G5		73G-ITCJ	73G-ITCK	73G-ITCR	73G-ITCT
Specifications	Units				
Number of Inputs		1 Ch.	1 Ch.	1 Ch.	1 Ch.
Resolution	bits	12	12	12	12
Absolute Accuracy @ 25°C <sup>1,2</sup>	°C/count	0.18	0.25	0.23	0.10
Accuracy Drift w/Temp. <sup>2</sup>	°C	+/- 3.0	+/- 3.0	+/- 3.0	+/- 3.0
Maximum Offset	PPM/°C	+/- 100	+/- 100	+/- 100	+/- 100
Maximum Gain (0 to 60°C)	PPM/°C	+/- 55	+/- 55	+/- 55	+/- 55
Serial Data Format		12-bit packet	12-bit packet	12-bit packet	12-bit packet
Serial Data Packet		—	—	—	—
Step Response Time <sup>3</sup>	mS	2.5	2.5	2.5	2.5
Input Temperature Range	°C (°F)	0 to 700 (32-1292)	-100 to 924 (-148-1695)	0 to 960 (32-1760)	-200 to 224 (-328-435)
Maximum Overload	V	—	—	—	—
Logic Voltage Range	Vdc	4.5 to 5.5	4.5 to 5.5	4.5 to 5.5	4.5-5.5
Maximum Logic Supply					
Current @ 5V dc	mA/Ch.	150	150	150	150
Module ID (Pin 9)	KΩ	—	—	—	—
Isolation Voltage					
Field to Logic	Vrms	2500	2500	2500	2500
Field to Power	Vrms	2500	2500	2500	2500
Module to Module	Vrms	2500	2500	2500	2500
Channel A to Channel B		—	—	—	—
Environmental Conditions					
Operating Temperature <sup>3</sup>	°C	0 to 60	0 to 60	0 to 60	0-60
Storage Temperature	°C	-25 to 85	-25 to 85	-25 to 85	-25-85

Type/Function		Grayhill Part Number		
OpenLine®		73L-ITCJ	73L-ITCK	73L-ITCT
Specifications	Units			
Number of Inputs		2 Ch.	2 Ch.	2 Ch.
Resolution	bits	12	12	12
Absolute Accuracy @ 25°C <sup>1,2</sup>	°C/count	0.34	0.36	0.16
Accuracy Drift w/Temp. <sup>2</sup>	°C	+/- 1.0	+/- 1.0	+/- 0.4
Maximum Offset	PPM/°C	+/- 50	+/- 50	+/- 50
Maximum Gain (0 to 60°C)	PPM/°C	+/- 100	+/- 100	+/- 100
Serial Data Format		Right Justified,16-bit	Right Justified,16-bit	Right Justified,16-bit
Serial Data Packet		115.2 Kb, N, 8, 2	115.2 Kb, N, 8, 2	115.2 Kb, N, 8, 2
Step Response Time <sup>3</sup>	mS	100	100	100
Input Temperature Range	°C (°F)	-210 to 1200 (-346 to 2192)	-100 to 1372 (-148 to 2502)	-240 to 400 (-400 to 752)
Maximum Overload	V	+/- 6	+/- 6	+/- 6
Logic Voltage Range	Vdc	4.75 to 5.25	4.75 to 5.25	4.75 to 5.25
Maximum Logic Supply				
Current @ 5V dc	mA/Ch.	38	38	38
Module ID (Pin 9)	KΩ	5.23	5.23	5.23
Isolation Voltage				
Field to Logic	Vrms	2500	2500	2500
Field to Power	Vrms	2500	2500	2500
Module to Module	Vrms	2500	2500	2500
Channel A to Channel B		None	None	None
Environmental Conditions				
Operating Temperature <sup>3</sup>	°C	-40 to 85	-40 to 85	-40 to 85
Storage Temperature	°C	-55 to 100	-55 to 100	-55 to 100

<sup>1</sup> Includes offset, gain, non-linearity and repeatability error terms.

<sup>2</sup> Accuracy and drift graphs are available in Bulletin #753.

<sup>3</sup> Time required for output to change within 1% of final reading.

**Available from your local Grayhill Distributor.**

For prices and discounts, contact a local Distributor, a local Sales Office or Grayhill.