

54F/74F240•54F/74F241•54F/74F244 Octal Buffers/Line Drivers with TRI-STATE® Outputs

General Description

The 'F240, 'F241 and 'F244 are octal buffers and line drivers designed to be employed as memory and address drivers, clock drivers and bus-oriented transmitters/receivers which provide improved PC and board density.

Features

- TRI-STATE outputs drive bus lines or buffer memory address registers
- Outputs sink 64 mA (48 mA mil)
- 12 mA source current
- Input clamp diodes limit high-speed termination effects
- Guaranteed 4000V minimum ESD protection

Commercial	Military	Package Number	Package Description
74F240PC		N20A	20-Lead (0.300" Wide) Molded Dual-In-Line
	54F240DM (Note 2)	J20A	20-Lead Ceramic Dual-In-Line
74F240SC (Note 1)		M20B	20-Lead (0.300" Wide) Molded Small Outline, JEDEC
74F240SJ (Note 1)		M20D	20-Lead (0.300" Wide) Molded Small Outline, EIAJ
	54F240FM (Note 2)	W20A	20-Lead Cerpack
	54F240LM (Note 2)	E20A	20-Lead Ceramic Leadless Chip Carrier, Type C
74F241PC		N20A	20-Lead (0.300" Wide) Molded Dual-In-Line
	54F241DM (Note 2)	J20A	20-Lead Ceramic Dual-In-Line
74F241SC (Note 1)		M20B	20-Lead (0.300" Wide) Molded Small Outline, JEDEC
74F241SJ (Note 1)		M20D	20-Lead (0.300" Wide) Molded Small Outline, EIAJ
	54F241FM (Note 2)	W20A	20-Lead Cerpack
	54F241LM (Note 2)	E20A	20-Lead Ceramic Leadless Chip Carrier, Type C
74F244PC		N20A	20-Lead (0.300" Wide) Molded Dual-In-Line
	54F244DM (Note 2)	J20A	20-Lead Ceramic Dual-In-Line
74F244SC (Note 1)		M20B	20-Lead (0.300" Wide) Molded Small Outline, JEDEC
74F244SJ (Note 1)		M20D	20-Lead (0.300" Wide) Molded Small Outline, EIAJ
74F244MSA (Note 1)		MSA20	20-Lead Molded Shrink Small Outline, EIAJ Type II
	54F244FM (Note 2)	W20A	20-Lead Cerpack
	54F244LM (Note 2)	E20A	20-Lead Ceramic Leadless Chip Carrier, Type C

Note 1: Devices also available in 13" reel. Use Suffix = SCX, SJX and MSAX.

Note 2: Military grade device with environmental and burn-in processing. Use suffix = DMQB, FMQB and LMQB.

TRI-STATE® is a registered trademark of National Semiconductor Corporation.

Connection Diagrams

Pin Assignment for LCC

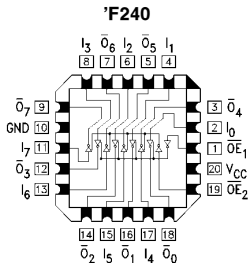

TL/F/9501-2

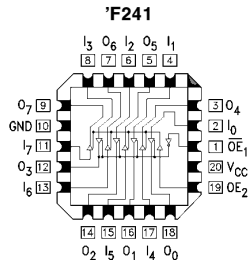

TL/F/9501-4

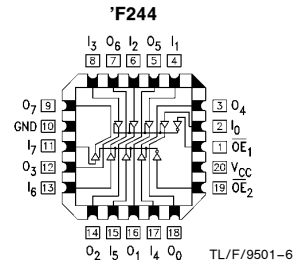

TL/F/9501-6

Pin Assignment for DIP, SOIC, SSOP and Flatpak

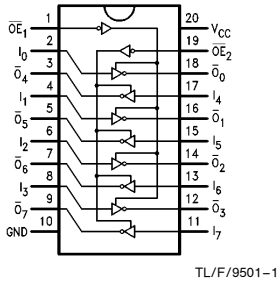

TL/F/9501-1

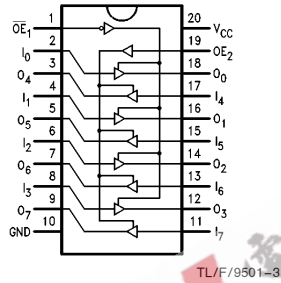

TL/F/9501-3

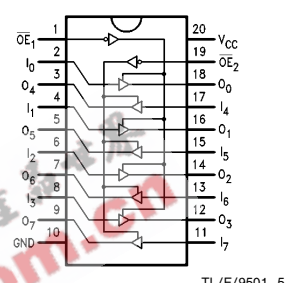

TL/F/9501-5

Logic Symbols

IEEE/IEC
'F240

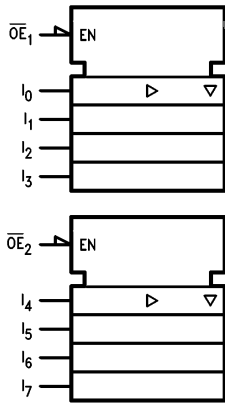

TL/F/9501-7

IEEE/IEC
'F241

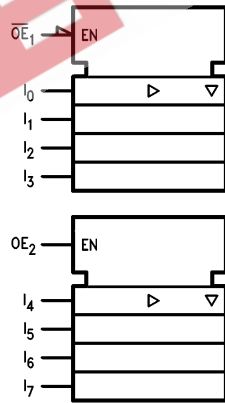

TL/F/9501-8

IEEE/IEC
'F244

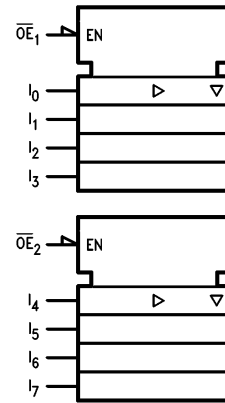

TL/F/9501-9

Unit Loading/Fan Out

Pin Names	Description	54F/74F	
		U.L. HIGH/LOW	Input I_{IH}/I_{IL} Output I_{OH}/I_{OL}
$\overline{OE}_1, \overline{OE}_2$	TRI-STATE Output Enable Input (Active LOW)	1.0/1.667	20 μA / -1 mA
OE_2	TRI-STATE Output Enable Input (Active HIGH)	1.0/1.667	20 μA / -1 mA
I_0-I_7	Inputs ('F240)	1.0/1.667*	20 μA / -1 mA
I_0-I_7	Inputs ('F241, 'F244)	1.0/2.667*	20 μA / -1.6 mA
$\overline{O}_0-\overline{O}_7, O_0-O_7$	Outputs	600/106.6 (80)	-12 mA/64 mA (48 mA)

*Worst-case 'F240 enabled; 'F241, 'F244 disabled

Truth Tables

'F240

\overline{OE}_1	D_{1n}	O_{1n}	\overline{OE}_2	D_{2n}	O_{2n}
H	X	Z	H	X	Z
L	H	L	L	H	L
L	L	H	L	L	H

'F244

\overline{OE}_1	D_{1n}	O_{1n}	\overline{OE}_2	D_{2n}	O_{2n}
H	X	Z	H	X	Z
L	H	H	L	H	H
L	L	L	L	L	L

'F241

\overline{OE}_1	D_{1n}	O_{1n}	OE_2	D_{2n}	O_{2n}
H	X	Z	L	X	Z
L	H	H	H	H	H
L	L	L	H	L	L

H = HIGH Voltage Level
L = LOW Voltage Level
X = Immaterial
Z = High Impedance

EEPW.com.cn 电子产品世界

Absolute Maximum Ratings (Note 1)

If Military/Aerospace specified devices are required, please contact the National Semiconductor Sales Office/Distributors for availability and specifications.

Storage Temperature	-65°C to +150°C
Ambient Temperature under Bias	-55°C to +125°C
Junction Temperature under Bias	-55°C to +175°C
Plastic	-55°C to +150°C
V _{CC} Pin Potential to Ground Pin	-0.5V to +7.0V
Input Voltage (Note 2)	-0.5V to +7.0V
Input Current (Note 2)	-30 mA to +5.0 mA
Voltage Applied to Output in HIGH State (with V _{CC} = 0V)	
Standard Output	-0.5V to V _{CC}
TRI-STATE Output	-0.5V to +5.5V
Current Applied to Output in LOW State (Max)	twice the rated I _{OL} (mA)
ESD Last Passing Voltage (Min)	4000V

Note 1: Absolute maximum ratings are values beyond which the device may be damaged or have its useful life impaired. Functional operation under these conditions is not implied.

Note 2: Either voltage limit or current limit is sufficient to protect inputs.

Recommended Operating Conditions

Free Air Ambient Temperature	
Military	-55°C to +125°C
Commercial	0°C to +70°C
Supply Voltage	
Military	+4.5V to +5.5V
Commercial	+4.5V to +5.5V

DC Electrical Characteristics

Symbol	Parameter	54F/74F			Units	V _{CC}	Conditions
		Min	Typ	Max			
V _{IH}	Input HIGH Voltage	2.0			V		Recognized as a HIGH Signal
V _{IL}	Input LOW Voltage				0.8	V	Recognized as a LOW Signal
V _{CD}	Input Clamp Diode Voltage				-1.2	V	Min I _{IN} = -18 mA
V _{OH}	Output HIGH Voltage	54F 10% V _{CC}	2.4		V	Min	I _{OH} = -3 mA
		54F 10% V _{CC}	2.0				I _{OH} = -12 mA
		74F 10% V _{CC}	2.4				I _{OH} = -3 mA
		74F 10% V _{CC}	2.0				I _{OH} = -15 mA
		74F 5% V _{CC}	2.7				I _{OH} = -3 mA
V _{OL}	Output LOW Voltage	54F 10% V _{CC}		0.55	V	Min	I _{OL} = 48 mA
		74F 10% V _{CC}		0.55			I _{OL} = 64 mA
I _{IH}	Input HIGH Current	54F		20.0	μA	Max	V _{IN} = 2.7V
		74F		5.0			
I _{BVI}	Input HIGH Current Breakdown Test	54F		100	μA	Max	V _{IN} = 7.0V
		74F		7.0			
I _{CEx}	Output HIGH Leakage Current	54F		250	μA	Max	V _{OUT} = V _{CC}
74F		50					
V _{ID}	Input Leakage Test	74F	4.75		V	0.0	I _{ID} = 1.9 μA All Other Pins Grounded
I _{OD}	Output Leakage Circuit Current	74F		3.75	μA	0.0	V _{IOD} = 150 mV All Other Pins Grounded
I _{IL}	Input LOW Current			-1.0 -1.6	mA	Max	V _{IN} = 0.5V ($\overline{OE}_1, \overline{OE}_2, OE_2, D_n$ ('F240)) V _{IN} = 0.5V (D _n ('F241, 'F244))
I _{OZH}	Output Leakage Current			50	μA	Max	V _{OUT} = 2.7V
I _{OZL}	Output Leakage Current			-50	μA	Max	V _{OUT} = 0.5V
I _{OS}	Output Short-Circuit Current			-100 -225	mA	Max	V _{OUT} = 0V
I _{ZZ}	Bus Drainage Test			500	μA	0.0V	V _{OUT} = 5.25V

DC Electrical Characteristics (Continued)							
Symbol	Parameter	54F/74F			Units	V _{CC}	Conditions
		Min	Typ	Max			
I _{CCH}	Power Supply Current ('F240)		19	29	mA	Max	V _O = HIGH
I _{CCL}	Power Supply Current ('F240)		50	75	mA	Max	V _O = LOW
I _{CCZ}	Power Supply Current ('F240)		42	63	mA	Max	V _O = HIGH Z
I _{CCH}	Power Supply Current ('F241, 'F244)		40	60	mA	Max	V _O = HIGH
I _{CCL}	Power Supply Current ('F241, 'F244)		60	90	mA	Max	V _O = LOW
I _{CCZ}	Power Supply Current ('F241, 'F244)		60	90	mA	Max	V _O = HIGH Z

AC Electrical Characteristics									
Symbol	Parameter	74F			54F		74F		Units
		T _A = +25°C V _{CC} = +5.0V C _L = 50 pF			T _A , V _{CC} = Mil C _L = 50 pF		T _A , V _{CC} = Com C _L = 50 pF		
		Min	Typ	Max	Min	Max	Min	Max	
t _{PLH}	Propagation Delay	3.0	5.1	7.0	3.0	9.0	3.0	8.0	ns
t _{PHL}	Data to Output ('F240)	2.0	3.5	4.7	2.0	6.0	2.0	5.7	
t _{PZH}	Output Enable Time ('F240)	2.0	3.5	4.7	2.0	6.5	2.0	5.7	ns
t _{PZL}	Output Disable Time ('F240)	4.0	6.9	9.0	4.0	10.5	4.0	10.0	
t _{PHZ}	Output Disable Time ('F240)	2.0	4.0	5.3	2.0	6.5	2.0	6.3	ns
t _{PLZ}	Output Disable Time ('F240)	2.0	6.0	8.0	2.0	12.5	2.0	9.5	
t _{PLH}	Propagation Delay	2.5	4.0	5.2	2.0	6.5	2.5	6.2	ns
t _{PHL}	Data to Output ('F241, 'F244)	2.5	4.0	5.2	2.0	7.0	2.5	6.5	
t _{PZH}	Output Enable Time ('F241, 'F244)	2.0	4.3	5.7	2.0	7.0	2.0	6.7	ns
t _{PZL}	Output Disable Time ('F241, 'F244)	2.0	5.4	7.0	2.0	8.5	2.0	8.0	
t _{PHZ}	Output Disable Time ('F241, 'F244)	2.0	4.5	6.0	2.0	7.0	2.0	7.0	ns
t _{PLZ}	Output Disable Time ('F241, 'F244)	2.0	4.5	6.0	2.0	7.5	2.0	7.0	

Ordering Information

The device number is used to form part of a simplified purchasing code where the package type and temperature range are defined as follows:

74F 240/241/244* S C X

Temperature Range Family
74F = Commercial
54F = Military

Device Type

Package Code
P = Plastic DIP
D = Ceramic DIP
F = Flatpak
L = Leadless Chip Carrier (LCC)
S = Small Outline SOIC JEDEC
*MSA = Shrink Small Outline Package (EIAJ SSOP) ('244 only)
SJ = Small Outline SOIC EIAJ

Special Variations
QB = Military grade device with environmental and burn-in processing
X = devices shipped in 13" reel

Temperature Range
C = Commercial (0°C to +70°C)
M = Military (-55°C to +125°C)
NOTE:
Not required for MSA package code

EEPW 电子产品世界
.com.cn

Physical Dimensions inches (millimeters)

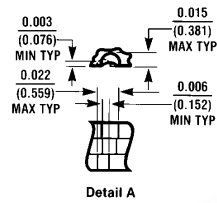
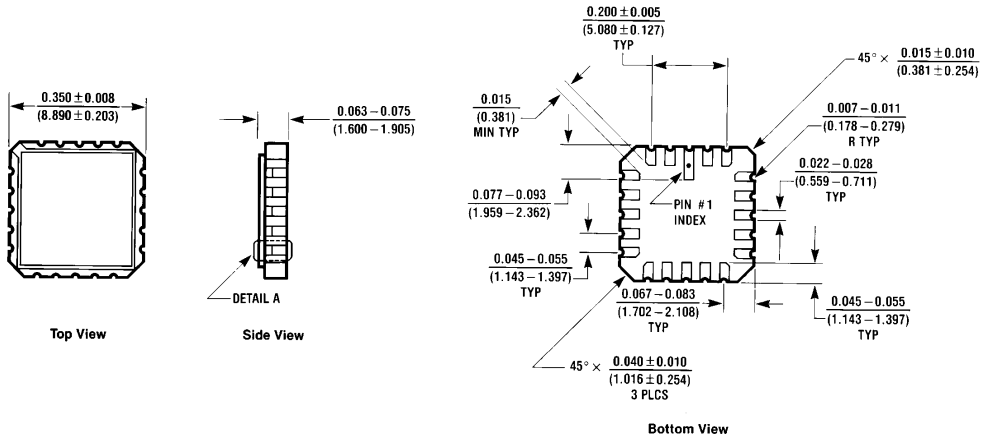

20-Lead Ceramic Leadless Chip Carrier (L)
 NS Package Number E20A

E20A (REV D)

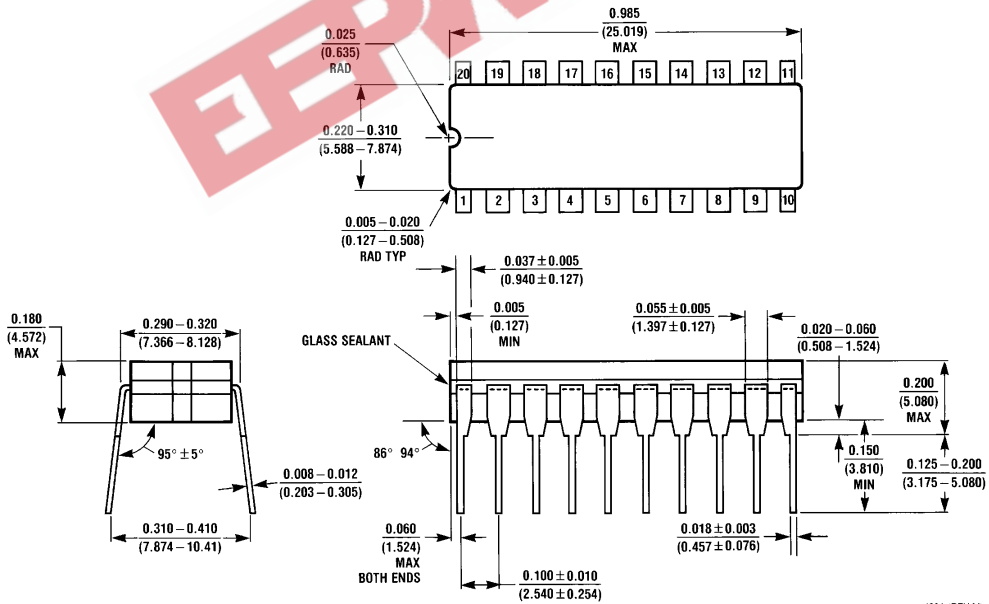

20-Lead Ceramic Dual-In-Line Package (D)
 NS Package Number J20A

J20A (REV M)

Physical Dimensions inches (millimeters) (Continued)

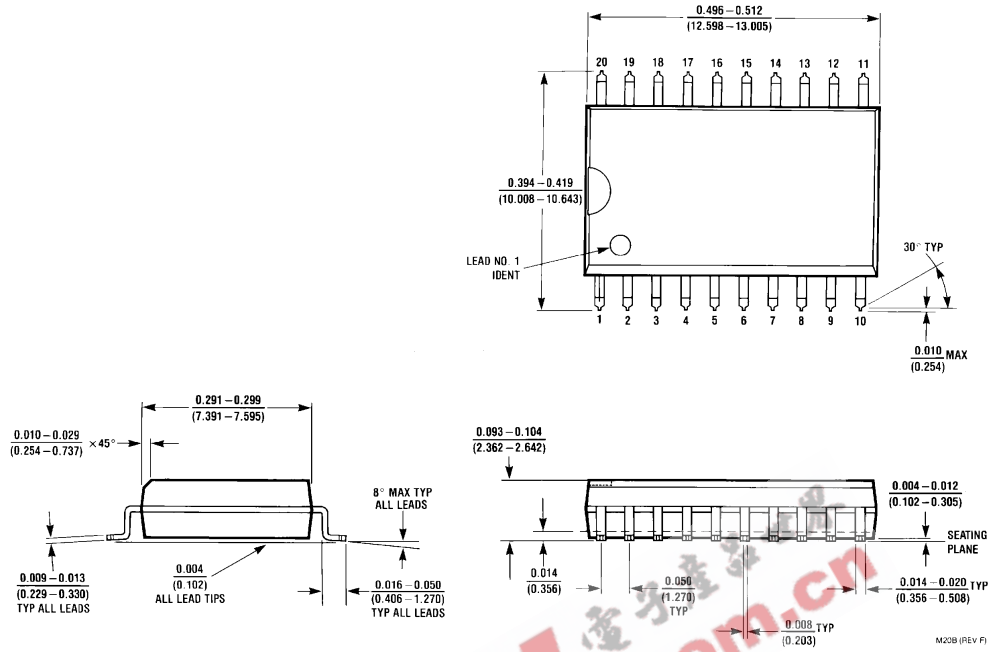

20-Lead (0.300" Wide) Molded Small Outline Package, JEDEC (S)
NS Package Number M20B

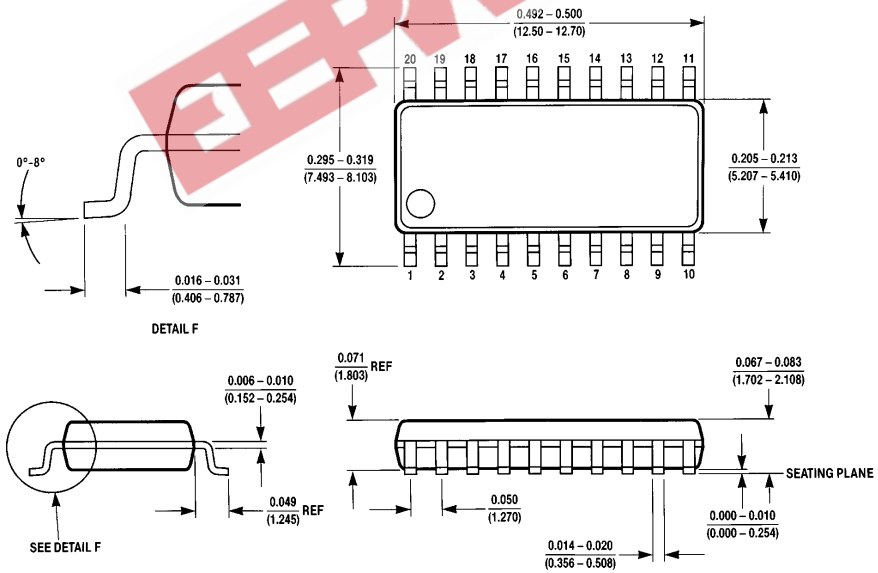

20-Lead (0.300" Wide) Molded Small Outline Package, EIAJ (SJ)
NS Package Number M20D

Physical Dimensions inches (millimeters) (Continued)

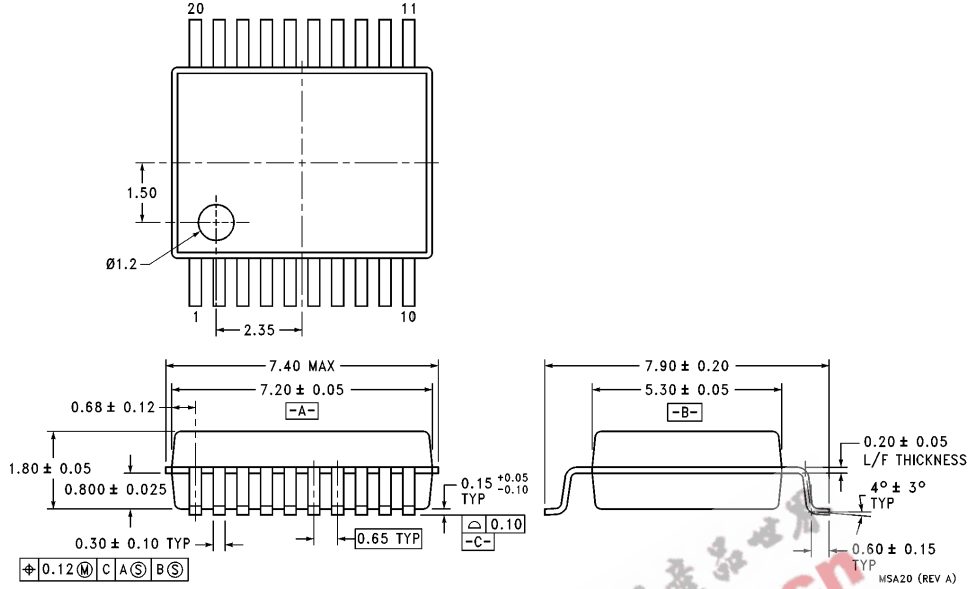

20-Lead Molded Shrink Small Outline, EIAJ Type II (MSA)
NS Package Number MSA20

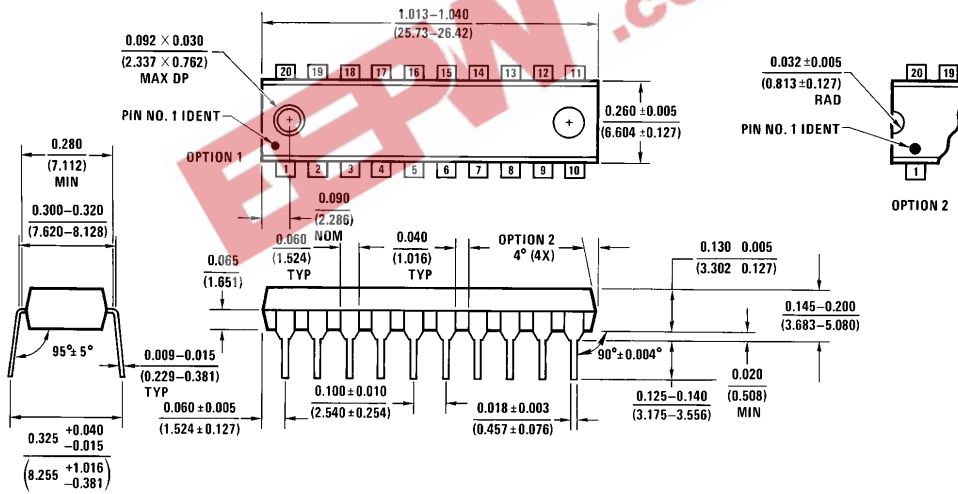

20-Lead (0.300" Wide) Molded Dual-In-Line Package (P)
NS Package Number N20A

Physical Dimensions inches (millimeters) (Continued)

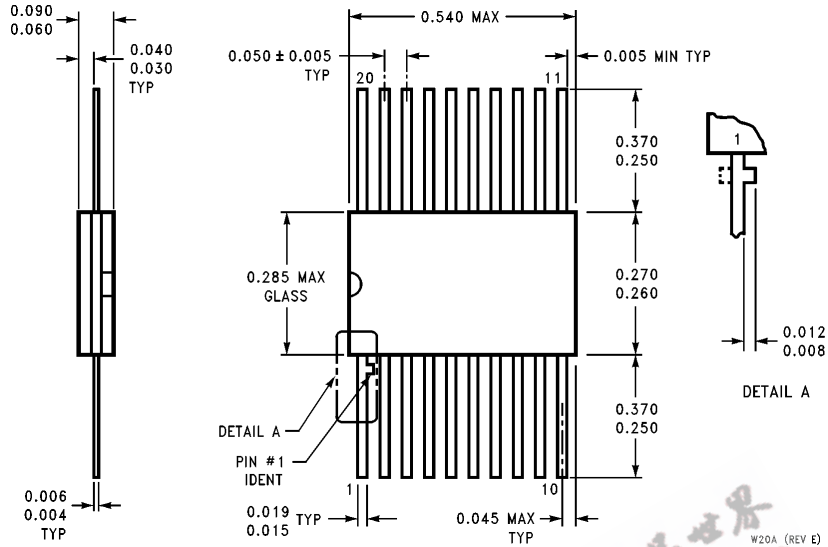

20-Lead Ceramic Flatpak (F)
NS Package Number W20A

LIFE SUPPORT POLICY

NATIONAL'S PRODUCTS ARE NOT AUTHORIZED FOR USE AS CRITICAL COMPONENTS IN LIFE SUPPORT DEVICES OR SYSTEMS WITHOUT THE EXPRESS WRITTEN APPROVAL OF THE PRESIDENT OF NATIONAL SEMICONDUCTOR CORPORATION. As used herein:

1. Life support devices or systems are devices or systems which, (a) are intended for surgical implant into the body, or (b) support or sustain life, and whose failure to perform, when properly used in accordance with instructions for use provided in the labeling, can be reasonably expected to result in a significant injury to the user.
2. A critical component is any component of a life support device or system whose failure to perform can be reasonably expected to cause the failure of the life support device or system, or to affect its safety or effectiveness.



National Semiconductor Corporation
2900 Semiconductor Drive
P.O. Box 58090
Santa Clara, CA 95052-8090
Tel: 1 (800) 272-9959
TWX: (910) 339-9240

National Semiconductor GmbH
Livry-Gargan-Str. 10
D-82256 Fürstenfeldbruck
Germany
Tel: (81-41) 35-0
Telex: 527649
Fax: (81-41) 35-1

National Semiconductor Japan Ltd.
Sumitomo Chemical
Engineering Center
Bldg. 7F
1-7-1, Nakase, Mihama-Ku
Chiba-City,
Chiba Prefecture 261
Tel: (043) 299-2300
Fax: (043) 299-2500

National Semiconductor Hong Kong Ltd.
13th Floor, Straight Block,
Ocean Centre, 5 Canton Rd.
Tsimshatsui, Kowloon
Hong Kong
Tel: (852) 2737-1600
Fax: (852) 2736-9960

National Semiconductores Do Brazil Ltda.
Rua Deputado Lacorda Franco
120-3A
Sao Paulo-SP
Brazil 05418-000
Tel: (55-11) 212-5066
Telex: 391-1131931 NSBR BR
Fax: (55-11) 212-1181

National Semiconductor (Australia) Pty, Ltd.
Building 16
Business Park Drive
Monash Business Park
Nottingham, Melbourne
Victoria 3168 Australia
Tel: (3) 558-9889
Fax: (3) 558-9898

National does not assume any responsibility for use of any circuitry described, no circuit patent licenses are implied and National reserves the right at any time without notice to change said circuitry and specifications.