

DATA SHEET

EEPW 电子产品世界
.com.cn

74F365, 74F366*, 74F367, 74F368* **Buffers/drivers**

** Discontinued part. Please see the Discontinued Product List.*

Product specification
Supersedes data of 1990 Jan 08
IC15 Data Handbook

1999 Jan 08

Buffers/drivers

74F365, 74F366*
74F367, 74F368*

74F365, 74F367 Hex Buffer/Driver (3-State)
74F366, 74F368 Hex Inverter Buffer/Driver (3-State)

FEATURES

- High-impedance NPN base inputs for reduced loading (20µA in High and Low states)
- High-speed
- Bus oriented
- 3-State buffer outputs sink 64mA

TYPE	TYPICAL PROPAGATION DELAY	TYPICAL SUPPLY CURRENT (TOTAL)
74F365, 74F367	5.0ns	36mA
74F366, 74F368	5.0ns	33mA

ORDERING INFORMATION

DESCRIPTION	COMMERCIAL RANGE $V_{CC} = 5V \pm 10\%$, $T_{amb} = 0^{\circ}C \text{ to } +70^{\circ}C$	PKG DWG #
16-pin plastic DIP	N74F365N, N74F367N	SOT38-4
16-pin plastic SO	N74F365D, N74F367D	SOT109-1

INPUT AND OUTPUT LOADING AND FAN-OUT TABLE

PINS	DESCRIPTION	74F(U.L.) HIGH/LOW	LOAD VALUE HIGH/LOW
I0 - I5	Inputs	1.0/0.033	20µA/20µA
OE0, OE1	Output enable inputs (active Low)	1.0/0.033	20µA/20µA
Y0 - Y5, Y0 - Y5	Data Outputs	750/106.7	15mA/64mA

NOTE: One (1.0) FAST Unit Load (U.L.) is defined as: 20µA in the High state and 0.6mA in the Low state.

PIN CONFIGURATION

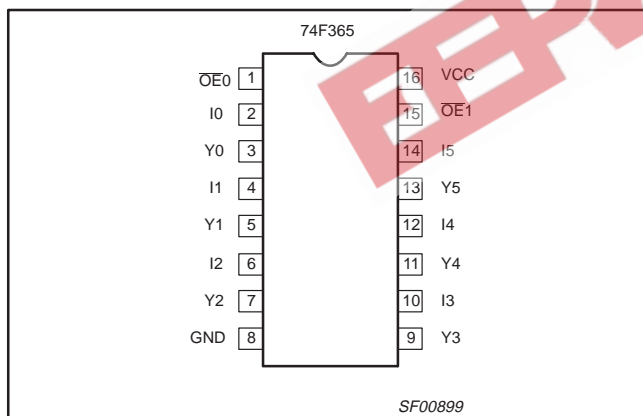

LOGIC SYMBOL (IEEE/IEC)

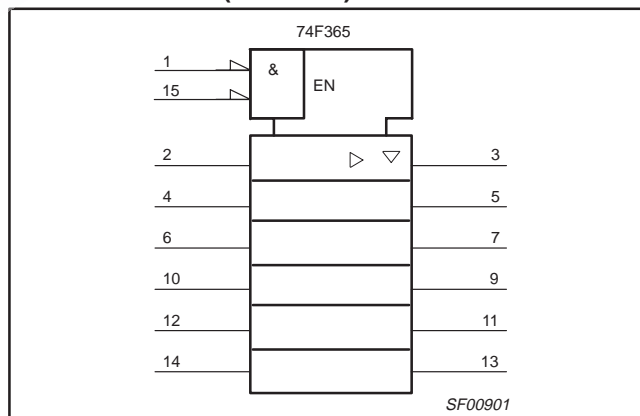

LOGIC SYMBOL

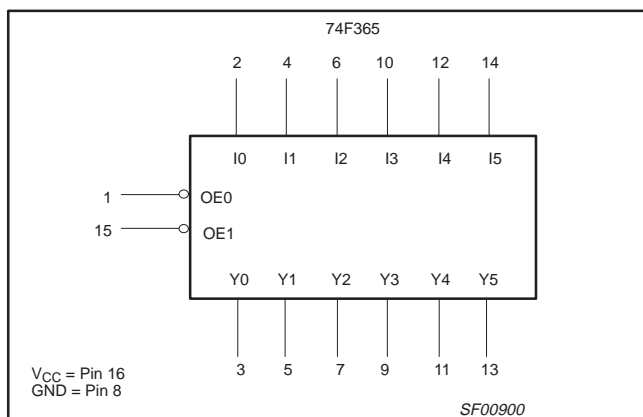

PIN CONFIGURATION

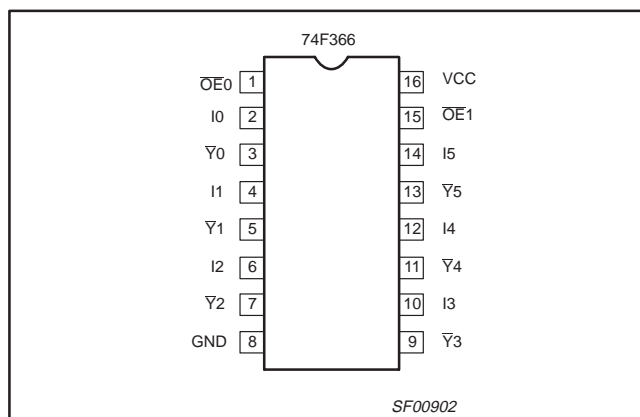

* Discontinued part. Please see the Discontinued Products List.
1999 Jan 08

Buffers/drivers

74F365, 74F366*
74F367, 74F368*

LOGIC SYMBOL

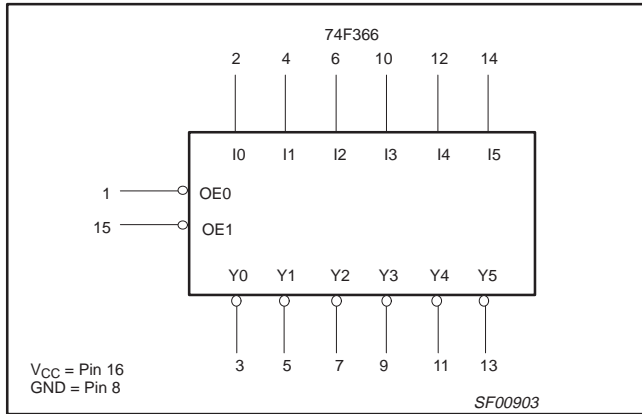

LOGIC SYMBOL

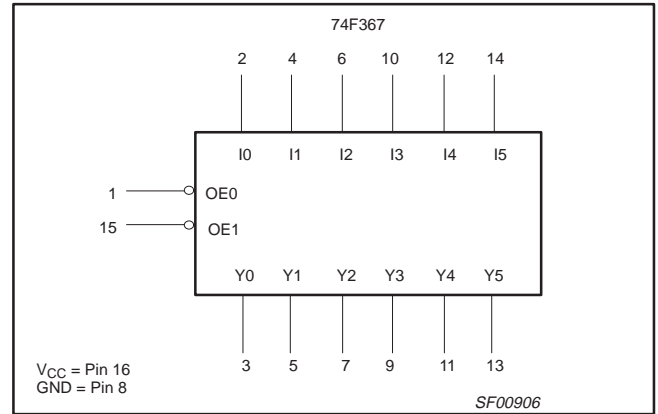

LOGIC SYMBOL (IEEE/IEC)

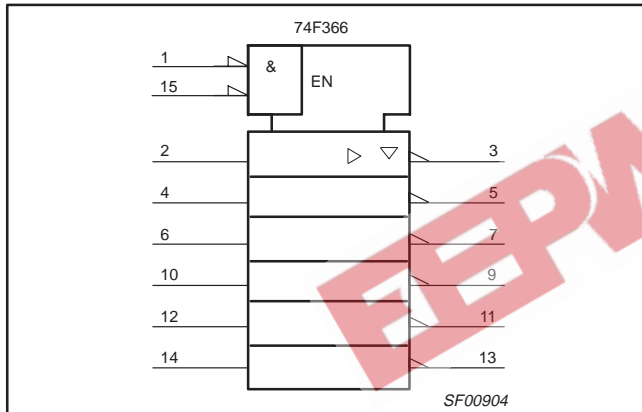

LOGIC SYMBOL (IEEE/IEC)

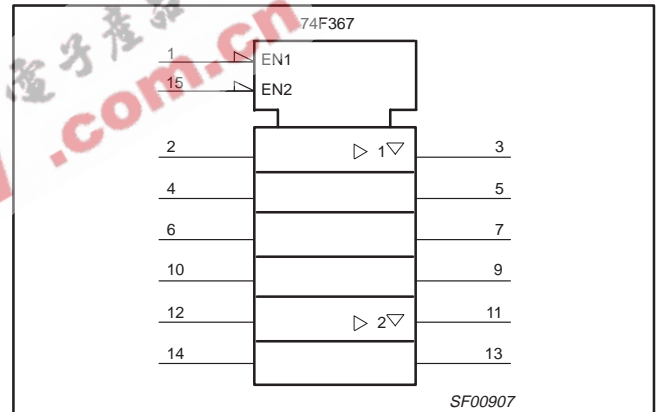

PIN CONFIGURATION

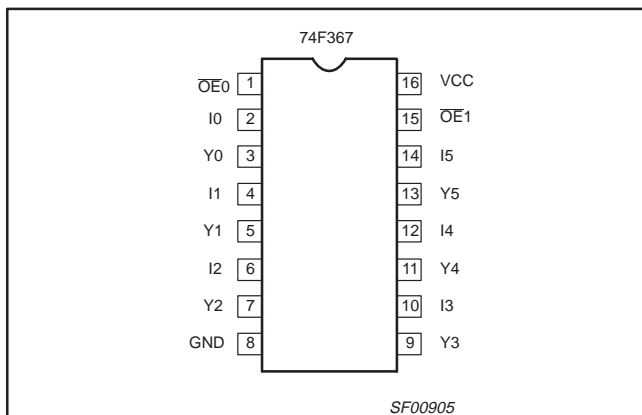

PIN CONFIGURATION

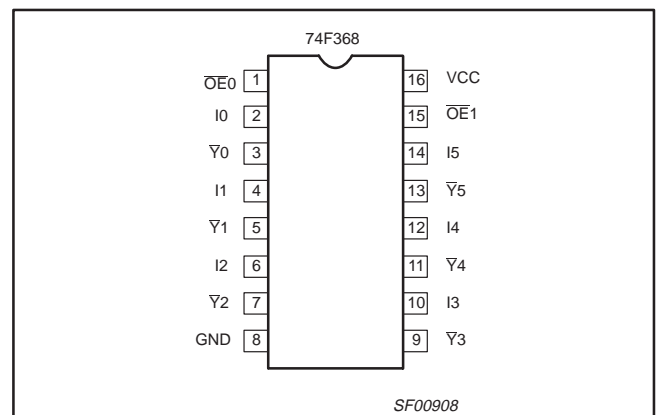

* Discontinued part. Please see the Discontinued Products List.

Buffers/drivers

74F365, 74F366*
74F367, 74F368*

LOGIC SYMBOL

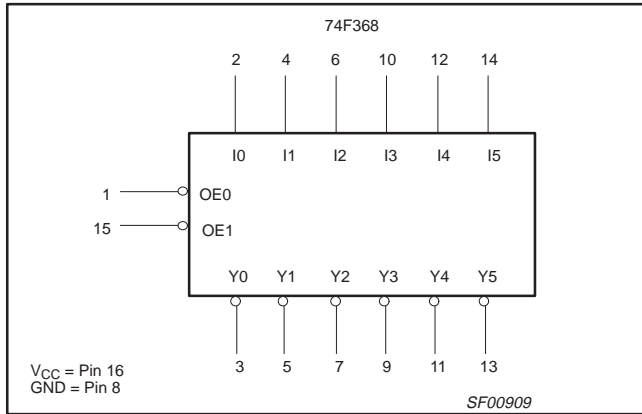

LOGIC SYMBOL (IEEE/IEC)

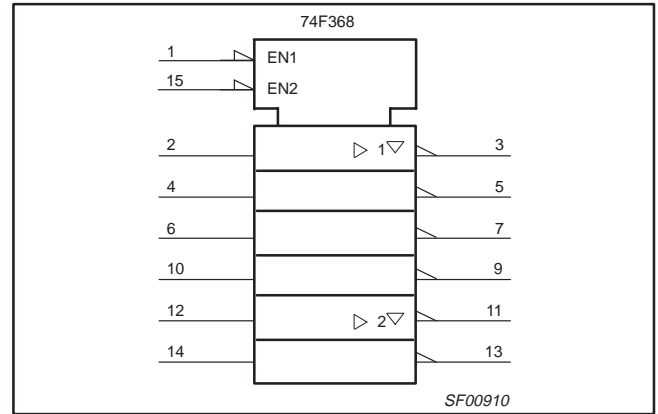

LOGIC DIAGRAMS

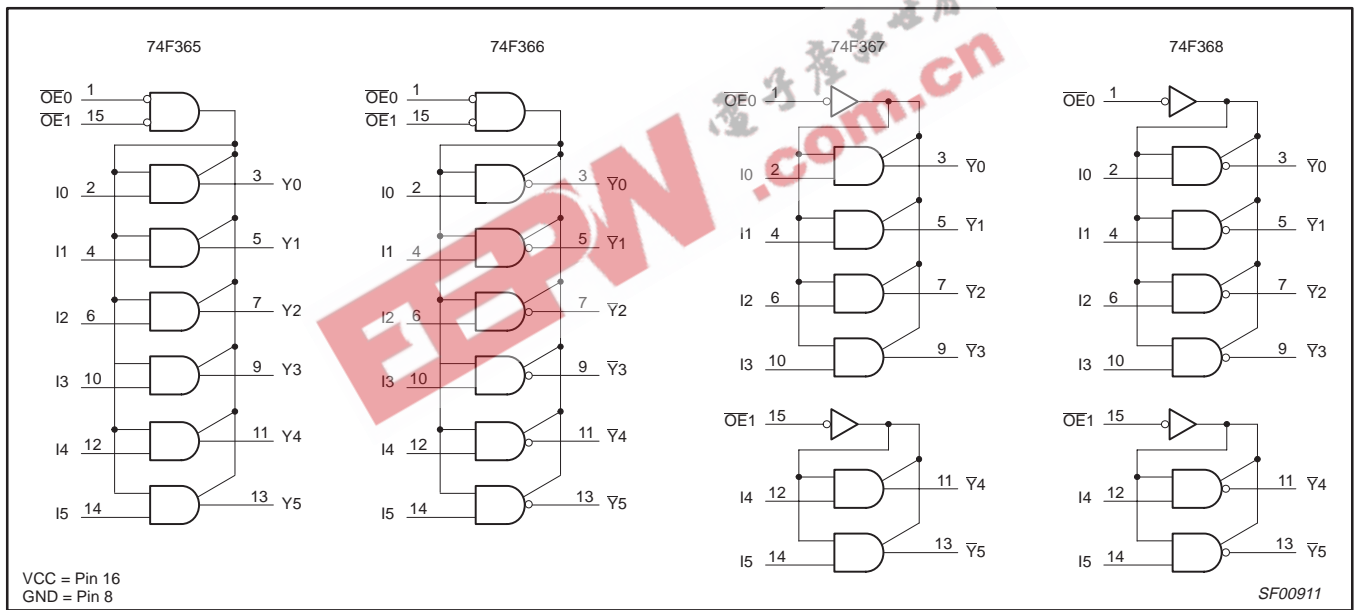

FUNCTION TABLE for 74F365 and 74F366

INPUTS			OUTPUTS	
OE0	OE1	In	Yn	Ȳn
L	L	L	L	H
L	L	H	H	L
X	H	X	Z	Z
H	X	X	Z	Z

H = High voltage level
L = Low voltage level
X = Don't care
Z = High impedance "off" state

FUNCTION TABLE for 74F367 and 74F368

INPUTS		OUTPUTS	
OE _n	In	Yn	Ȳn
L	L	L	H
L	H	H	L
H	X	Z	Z

H = High voltage level
L = Low voltage level
X = Don't care
Z = High impedance "off" state

* Discontinued part. Please see the Discontinued Products List.

Buffers/drivers

74F365, 74F366*
74F367, 74F368***ABSOLUTE MAXIMUM RATINGS**

(Operation beyond the limits set forth in this table may impair the useful life of the device. Unless otherwise noted these limits are over the operating free-air temperature range.)

SYMBOL	PARAMETER	RATING	UNIT
V _{CC}	Supply voltage range	−0.5 to +7.0	V
V _{IN}	Input voltage range	−0.5 to +7.0	V
I _{IN}	Input current range	−30 to +5	mA
V _{OUT}	Voltage applied to output in High output state range	−0.5 to 5.5	V
I _{OUT}	Current applied to output in Low output state	128	mA
T _{amb}	Operating free-air temperature range	0 to +70	°C
T _{STG}	Storage temperature range	−65 to +150	°C

RECOMMENDED OPERATING CONDITIONS

SYMBOL	PARAMETER	LIMITS			UNIT
		MIN	TYP	MAX	
V _{CC}	Supply voltage	4.5	5.0	5.5	V
V _{IH}	High-level input voltage	2.0			V
V _{IL}	Low-level input voltage			0.8	V
I _{IK}	Input clamp current			−18	mA
I _{OH}	High-level output current			−15	mA
I _{OL}	Low-level output current			64	mA
T _{amb}	Operating free-air temperature range	0		70	°C

* Discontinued part. Please see the Discontinued Products List.

Buffers/drivers

74F365, 74F366*
74F367, 74F368*

DC ELECTRICAL CHARACTERISTICS

Over recommended operating free-air temperature range unless otherwise noted.

SYMBOL	PARAMETER	TEST CONDITIONS ^{NO TAG}	LIMITS			UNIT		
			MIN	TYP NO TAG	MAX			
V _{OH}	High-level output voltage	V _{CC} = MIN, V _{IL} = MAX, V _{IH} = MIN, I _{OH} = -3mA	± 10%V _{CC}	2.4		V		
			± 5%V _{CC}	2.7	3.3	V		
		V _{CC} = MIN, V _{IL} = MAX, V _{IH} = MIN, I _{OH} = -15mA	± 10%V _{CC}	2.0		V		
			± 5%V _{CC}	2.0		V		
V _{OL}	Low-level output voltage	V _{CC} = MIN, V _{IL} = MAX, V _{IH} = MIN, I _{OL} = MAX	± 10%V _{CC}		0.55	V		
			± 5%V _{CC}		0.42	0.55	V	
V _{IK}	Input clamp voltage	V _{CC} = MIN, I _I = I _{IK}		-0.73	-1.2	V		
I _I	Input current at maximum input voltage	V _{CC} = 0.0V, V _I = 7.0V			100	μA		
I _{IH}	High-level input current	V _{CC} = MAX, V _I = 2.7V			20	μA		
I _{IL}	Low-level input current	V _{CC} = MAX, V _I = 0.5V			-20	μA		
I _{OZH}	Off-state output current, High-level voltage applied	V _{CC} = MAX, V _O = 2.7V			50	μA		
I _{OZL}	Off-state output current, Low-level voltage applied	V _{CC} = MAX, V _O = 0.5V			-50	μA		
I _{OS}	Short-circuit output current ^{NO TAG}	V _{CC} = MAX	-100		-225	mA		
I _{CC}	Supply current (total)	V _{CC} = MAX	74F365	I _{CCH}		25	35	mA
			74F367	I _{CCL}		47	62	mA
				I _{CCZ}		35	48	mA
			74F366	I _{CCH}		18	25	mA
			74F368	I _{CCL}		47	62	mA
				I _{CCZ}		35	48	mA

NOTES:

- For conditions shown as MIN or MAX, use the appropriate value specified under recommended operating conditions for the applicable type.
- All typical values are at V_{CC} = 5V, T_{amb} = 25°C.
- Not more than one output should be shorted at a time. For testing I_{OS}, the use of high-speed test apparatus and/or sample-and-hold techniques are preferable in order to minimize internal heating and more accurately reflect operational values. Otherwise, prolonged shorting of a High output may raise the chip temperature well above normal and thereby cause invalid readings in other parameter tests. In any sequence of parameter tests, I_{OS} tests should be performed last.

AC ELECTRICAL CHARACTERISTICS

SYMBOL	PARAMETER	TEST CONDITIONS	LIMITS						UNIT
			T _A = +25°C V _{CC} = +5.0V C _L = 50pF, R _L = 500Ω			T _A = -55°C to +125°C V _{CC} = +5.0V ± 10% C _L = 50pF, R _L = 500Ω			
			MIN	TYP	MAX	MIN	MAX		
t _{PLH} t _{PHL}	Propagation delay I _n to \bar{Y}_n	74F366, 74F368	Waveform 1	3.0 2.0	5.0 3.0	6.5 5.0	3.0 1.5	7.5 5.5	ns ns
t _{PLH} t _{PHL}	Propagation delay I _n to Y _n	74F365, 74F367	Waveform 2	2.5 2.5	4.5 5.5	6.5 7.0	2.0 2.0	7.0 7.5	ns ns
t _{PZH} t _{PZL}	Output Enable time to High or Low level	74F365, 74F366	Waveform 3 Waveform 4	2.5 2.5	4.0 5.0	6.5 8.0	2.5 2.5	7.5 8.5	ns ns
t _{PZH} t _{PZL}	Output Enable time to High or Low level	74F367, 74F368	Waveform 3 Waveform 4	3.0 3.0	5.5 6.5	7.5 8.5	3.0 3.0	8.5 9.0	ns ns
t _{PHZ} t _{PLZ}	Output Disable time from High to Low level		Waveform 3 Waveform 4	2.0 2.0	4.5 4.0	6.5 6.5	2.0 2.0	7.0 7.0	ns ns

* Discontinued part. Please see the Discontinued Products List.

Buffers/drivers

74F365, 74F366*
74F367, 74F368*

AC WAVEFORMS

For all waveforms, $V_m = 1.5V$

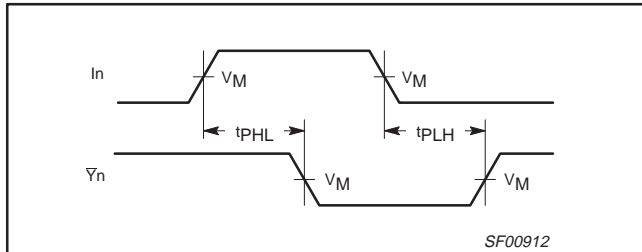

Waveform 1. For Inverting Outputs

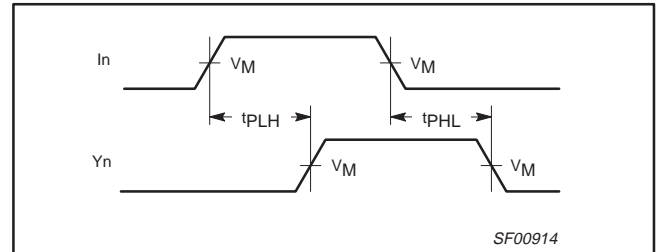

Waveform 2. For Non-Inverting Outputs

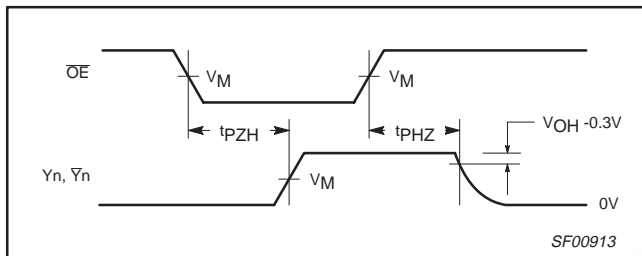

Waveform 3. 3-State Output Enable Time to High Level and Output Disable Time from High Level

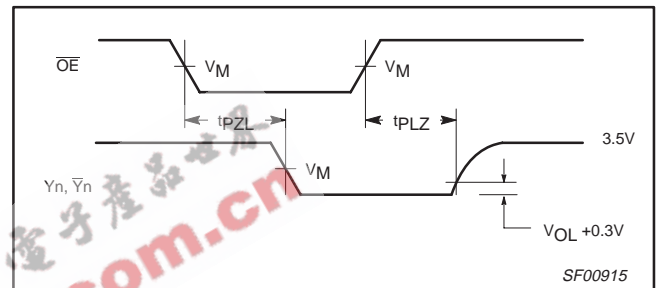

Waveform 4. 3-State Output Enable Time to Low Level and Output Disable Time from Low Level

TEST CIRCUIT AND WAVEFORM

Test Circuit for 3-State Outputs

SWITCH POSITION	
TEST	SWITCH
t_{pLZ}	closed
t_{pZL}	closed
All other	open

DEFINITIONS:
 R_L = Load resistor; see AC electrical characteristics for value.
 C_L = Load capacitance includes jig and probe capacitance; see AC electrical characteristics for value.
 R_T = Termination resistance should be equal to Z_{OUT} of pulse generators.

Input Pulse Definition

family	INPUT PULSE REQUIREMENTS					
	amplitude	V_m	rep. rate	t_w	t_{TLH}	t_{THL}
74F	3.0V	1.5V	1MHz	500ns	2.5ns	2.5ns

SF00777

* Discontinued part. Please see the Discontinued Products List.

Buffers/drivers

74F365, 74F366*,
74F367, 74F368*

DIP16: plastic dual in-line package; 16 leads (300 mil)

SOT38-4

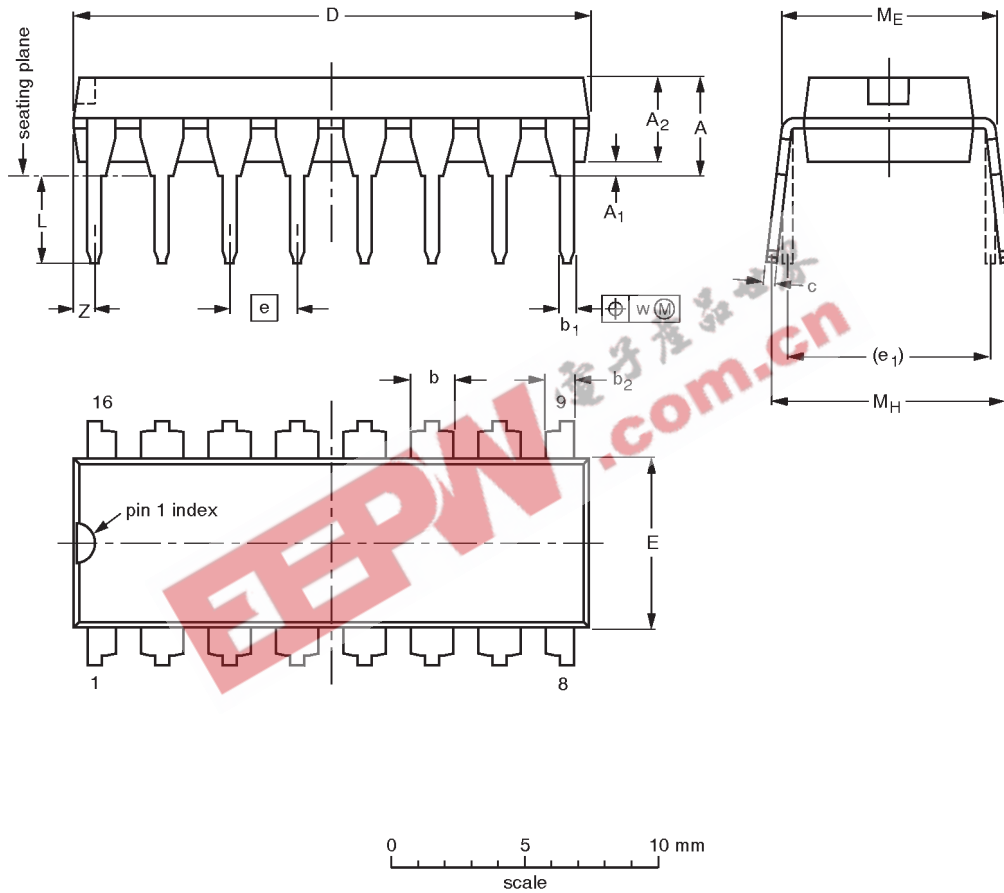

DIMENSIONS (inch dimensions are derived from the original mm dimensions)

UNIT	A max.	A ₁ min.	A ₂ max.	b	b ₁	b ₂	c	D ⁽¹⁾	E ⁽¹⁾	e	e ₁	L	M _E	M _H	w	z ⁽¹⁾ max.
mm	4.2	0.51	3.2	1.73 1.30	0.53 0.38	1.25 0.85	0.36 0.23	19.50 18.55	6.48 6.20	2.54	7.62	3.60 3.05	8.25 7.80	10.0 8.3	0.254	0.76
inches	0.17	0.020	0.13	0.068 0.051	0.021 0.015	0.049 0.033	0.014 0.009	0.77 0.73	0.26 0.24	0.10	0.30	0.14 0.12	0.32 0.31	0.39 0.33	0.01	0.030

Note

1. Plastic or metal protrusions of 0.25 mm maximum per side are not included.

OUTLINE VERSION	REFERENCES				EUROPEAN PROJECTION	ISSUE DATE
	IEC	JEDEC	EIAJ			
SOT38-4						92-11-17 95-01-14

* Discontinued part. Please see the Discontinued Product List.

Buffers/drivers

74F365, 74F366*,
74F367, 74F368*

SO16: plastic small outline package; 16 leads; body width 3.9 mm

SOT109-1

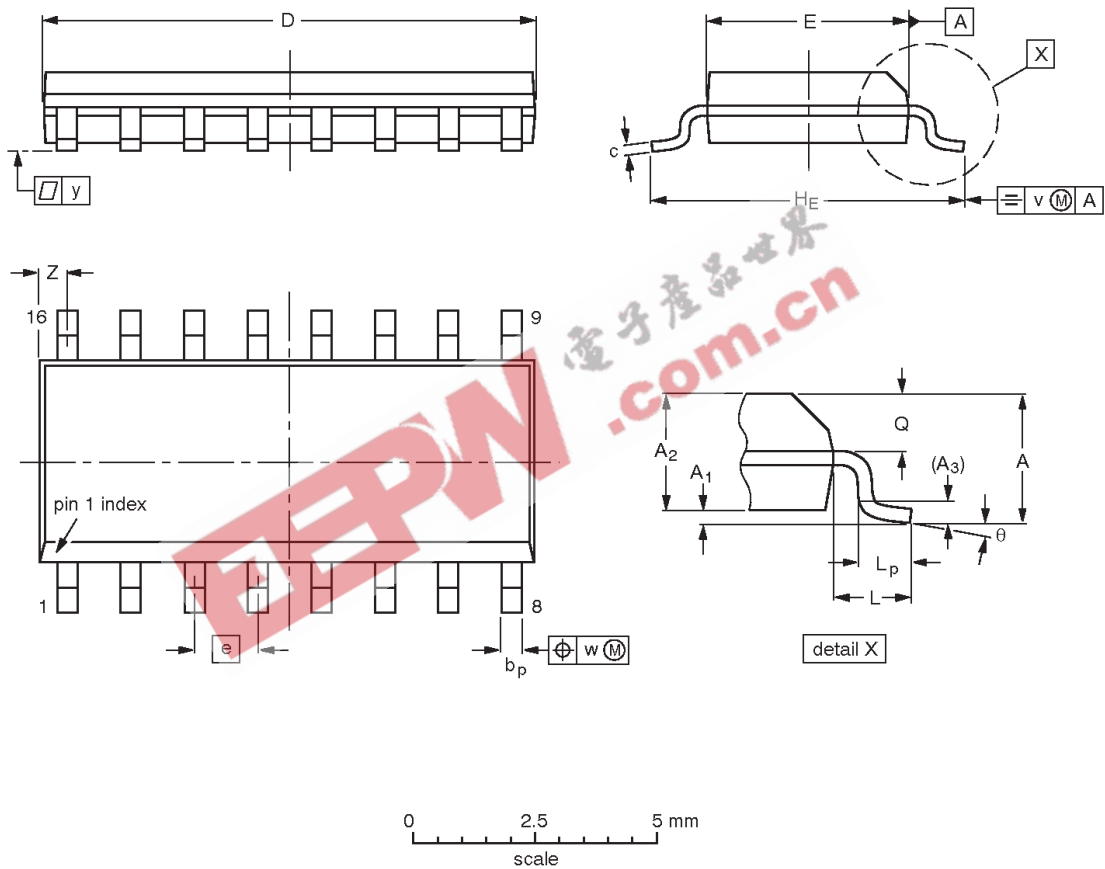

DIMENSIONS (inch dimensions are derived from the original mm dimensions)

UNIT	A max.	A ₁	A ₂	A ₃	b _p	c	D ⁽¹⁾	E ⁽¹⁾	e	H _E	L	L _p	Q	v	w	y	Z ⁽¹⁾	θ
mm	1.75	0.25 0.10	1.45 1.25	0.25	0.49 0.36	0.25 0.19	10.0 9.8	4.0 3.8	1.27	6.2 5.8	1.05	1.0 0.4	0.7 0.6	0.25	0.25	0.1	0.7 0.3	8° 0°
inches	0.069	0.010 0.004	0.057 0.049	0.01	0.019 0.014	0.0100 0.0075	0.39 0.38	0.16 0.15	0.050	0.244 0.228	0.041	0.039 0.016	0.028 0.020	0.01	0.01	0.004	0.028 0.012	

Note

1. Plastic or metal protrusions of 0.15 mm maximum per side are not included.

OUTLINE VERSION	REFERENCES				EUROPEAN PROJECTION	ISSUE DATE
	IEC	JEDEC	EIAJ			
SOT109-1	076E07S	MS-012AC				95-01-23 97-05-22

* Discontinued part. Please see the Discontinued Product List.

Buffers/drivers

74F365, 74F366*,
74F367, 74F368*

Data sheet status

Data sheet status	Product status	Definition [1]
Objective specification	Development	This data sheet contains the design target or goal specifications for product development. Specification may change in any manner without notice.
Preliminary specification	Qualification	This data sheet contains preliminary data, and supplementary data will be published at a later date. Philips Semiconductors reserves the right to make changes at any time without notice in order to improve design and supply the best possible product.
Product specification	Production	This data sheet contains final specifications. Philips Semiconductors reserves the right to make changes at any time without notice in order to improve design and supply the best possible product.

[1] Please consult the most recently issued datasheet before initiating or completing a design.

Definitions

Short-form specification — The data in a short-form specification is extracted from a full data sheet with the same type number and title. For detailed information see the relevant data sheet or data handbook.

Limiting values definition — Limiting values given are in accordance with the Absolute Maximum Rating System (IEC 134). Stress above one or more of the limiting values may cause permanent damage to the device. These are stress ratings only and operation of the device at these or at any other conditions above those given in the Characteristics sections of the specification is not implied. Exposure to limiting values for extended periods may affect device reliability.

Application information — Applications that are described herein for any of these products are for illustrative purposes only. Philips Semiconductors make no representation or warranty that such applications will be suitable for the specified use without further testing or modification.

Disclaimers

Life support — These products are not designed for use in life support appliances, devices or systems where malfunction of these products can reasonably be expected to result in personal injury. Philips Semiconductors customers using or selling these products for use in such applications do so at their own risk and agree to fully indemnify Philips Semiconductors for any damages resulting from such application.

Right to make changes — Philips Semiconductors reserves the right to make changes, without notice, in the products, including circuits, standard cells, and/or software, described or contained herein in order to improve design and/or performance. Philips Semiconductors assumes no responsibility or liability for the use of any of these products, conveys no license or title under any patent, copyright, or mask work right to these products, and makes no representations or warranties that these products are free from patent, copyright, or mask work right infringement, unless otherwise specified.

Philips Semiconductors
811 East Arques Avenue
P.O. Box 3409
Sunnyvale, California 94088-3409
Telephone 800-234-7381

© Copyright Philips Electronics North America Corporation 1998
All rights reserved. Printed in U.S.A.

print code

Date of release: 10-98

Document order number:

9397-750-05118

* Discontinued part. Please see the Discontinued Product List.

Let's make things better.