

Features

- Low power, pin-compatible replacement for LCX and LPT families
- 5V tolerant inputs and outputs
- 24 mA balanced drive outputs
- Power-off disable outputs permits live insertion
- Edge-rate control circuitry for reduced noise
- FCT-C speed at 5.2 ns
- Latch-up performance exceeds JEDEC standard no. 17
- Typical output skew < 250 ps
- Industrial temperature range of -40°C to +85°C
- TSSOP (19.6-mil pitch) or SSOP (25-mil pitch)
- Typical V_{Olp} (ground bounce) performance exceeds Mil Std 883D
- $V_{CC} = 2.7V$ to $3.6V$
- ESD (HBM) > 2000V

CY74FCT163H374

- Bus hold on data inputs
- Eliminates the need for external pull-up or pull-down resistors
- Devices with bus hold are not recommended for translating rail-to-rail CMOS signals to 3.3V logic levels

Functional Description

These devices are 16-bit D-type registers designed for use as buffered registers in high-speed, low power bus applications. These devices can be used as two independent 8-bit registers or as a single 16-bit register by connecting the output Enable (\overline{OE}) and Clock (CLK) inputs. The outputs are 24-mA balanced output drivers with current limiting resistors to reduce the need for external terminating resistors, and provide for minimal undershoot and reduced ground bounce. Flow-through pinout and small shrink packaging aid in simplifying board layout.

The CY74FCT163H374 has "bus hold" on the data inputs, which retains the input's last state whenever the source driving the input goes to high impedance. This eliminates the need for pull-up/down resistors and prevents floating inputs.

The CY74FCT163374 is designed with inputs and outputs capable of being driven by 5.0V buses, allowing its use in mixed voltage systems as a translator. The outputs are also designed with a power off disable feature enabling its use in applications requiring live insertion.

Logic Block Diagrams CY74FCT163374, CY74FCT163H374

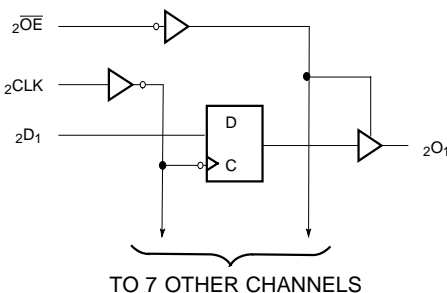
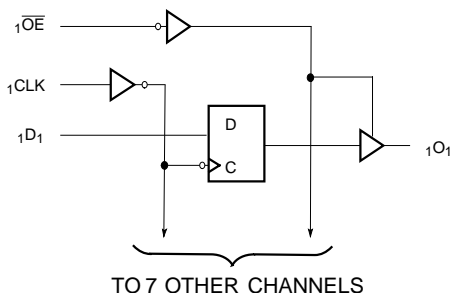

Pin Configuration

**SSOP/TSSOP
Top View**

1 \overline{OE}	1	48	1CLK
1 O_1	2	47	1 D_1
1 O_2	3	46	1 D_2
GND	4	45	GND
1 O_3	5	44	1 D_3
1 O_4	6	43	1 D_4
VCC	7	42	VCC
1 O_5	8	41	1 D_5
1 O_6	9	40	1 D_6
GND	10	39	GND
1 O_7	11	38	1 D_7
1 O_8	12	37	1 D_8
2 O_1	13	36	2 D_1
2 O_2	14	35	2 D_2
GND	15	34	GND
2 O_3	16	33	2 D_3
2 O_4	17	32	2 D_4
VCC	18	31	VCC
2 O_5	19	30	2 D_5
2 O_6	20	29	2 D_6
GND	21	28	GND
2 O_7	22	27	2 D_7
2 O_8	23	26	2 D_8
2 \overline{OE}	24	25	2CLK

Function Table^[1]

Inputs			Outputs	Function
D	CLK	OE	O	
X	L	H	Z	High-Z
X	H	H	Z	
L	┐	L	L	Load Register
H	┐	L	H	
L	┐	H	Z	
H	┐	H	Z	

Pin Description

Name	Description
D	Data Inputs ^[2]
CLK	Clock Inputs
OE	Three-State Output Enable Inputs (Active LOW)
O	Three-State Outputs

Maximum Ratings^[3, 4]

(Above which the useful life may be impaired. For user guidelines, not tested.)

Storage Temperature	-55°C to +125°C
Ambient Temperature with Power Applied	-55°C to +125°C
Supply Voltage Range	0.5V to +4.6V
DC Input Voltage	-0.5V to +7.0V
DC Output Voltage	-0.5V to +7.0V
DC Output Current (Maximum Sink Current/Pin)	-60 to +120 mA
Power Dissipation	1.0W

Operating Range

Range	Ambient Temperature	V _{CC}
Industrial	-40°C to +85°C	2.7V to 3.6V

Electrical Characteristics for Non Bus Hold Devices Over the Operating Range V_{CC}=2.7V to 3.6V

Parameter	Description	Test Conditions	Min.	Typ. ^[5]	Max.	Unit
V _{IH}	Input HIGH Voltage	All Inputs	2.0		5.5	V
V _{IL}	Input LOW Voltage				0.8	V
V _H	Input Hysteresis ^[6]			100		mV
V _{IK}	Input Clamp Diode Voltage	V _{CC} =Min., I _{IN} =-18 mA		-0.7	-1.2	V
I _{IH}	Input HIGH Current	V _{CC} =Max., V _I =5.5			±1	µA
I _{IL}	Input LOW Current	V _{CC} =Max., V _I =GND			±1	µA
I _{OZH}	High Impedance Output Current (Three-State Output pins)	V _{CC} =Max., V _{OUT} =5.5V			±1	µA
I _{OZL}	High Impedance Output Current (Three-State Output pins)	V _{CC} =Max., V _{OUT} =GND			±1	µA
I _{OS}	Short Circuit Current ^[7]	V _{CC} =Max., V _{OUT} =GND	-60	-135	-240	mA
I _{OFF}	Power-Off Disable	V _{CC} =0V, V _{OUT} ≤4.5V			±100	µA
I _{CC}	Quiescent Power Supply Current	V _{IN} ≤0.2V, V _{IN} ≥V _{CC} -0.2V, V _{CC} =Max.		0.1	10	µA
ΔI _{CC}	Quiescent Power Supply Current (TTL inputs HIGH)	V _{IN} =V _{CC} -0.6V ^[8] , V _{CC} =Max.		2.0	30	µA

Notes:

- H = HIGH Voltage Level. L = LOW Voltage Level. X = Don't Care. Z = HIGH Impedance. ┐ = LOW-to-HIGH Transition.
- On the CY74FCT163H374, these pins have "bus hold."
- Operation beyond the limits set forth may impair the useful life of the device. Unless otherwise noted, these limits are over the operating free-air temperature range.
- Unused inputs must always be connected to an appropriate logic voltage level, preferably either V_{CC} or ground
- Typical values are at V_{CC}=3.3V, T_A = +25°C ambient.
- This parameter is specified but not tested.
- Not more than one output should be shorted at a time. Duration of short should not exceed one second. The use of high-speed test apparatus and/or sample and hold techniques are preferable in order to minimize internal chip heating and more accurately reflect operational values. Otherwise prolonged shorting of a high output may raise the chip temperature well above normal and thereby cause invalid readings in other parametric tests. In any sequence of parameter tests, I_{OS} tests should be performed last.
- Per TTL driven input; all other inputs at V_{CC} or GND.

Electrical Characteristics For Bus Hold Devices Over the Operating Range $V_{CC}=2.7V$ to $3.6V$

Parameter	Description	Test Conditions	Min.	Typ. ^[5]	Max.	Unit
V_{IH}	Input HIGH Voltage	All Inputs	2.0		V_{CC}	V
V_{IL}	Input LOW Voltage				0.8	V
V_H	Input Hysteresis ^[6]			100		mV
V_{IK}	Input Clamp Diode Voltage	$V_{CC}=\text{Min.}, I_{IN}=-18\text{ mA}$		-0.7	-1.2	V
I_{IH}	Input HIGH Current	$V_{CC}=\text{Max.}, V_I=V_{CC}$			± 100	μA
I_{IL}	Input LOW Current				± 100	μA
I_{BBH} I_{BBL}	Bus Hold Sustain Current on Bus Hold Input ^[9]	$V_{CC}=\text{Min.}$ $V_I=2.0V$ $V_I=0.8V$	-50 +50			μA μA
I_{BHHO} I_{BHLO}	Bus Hold Overdrive Current on Bus Hold Input ^[9]	$V_{CC}=\text{Max.}, V_I=1.5V$			± 500	μA
I_{OZH}	High Impedance Output Current (Three-State Output pins)	$V_{CC}=\text{Max.}, V_{OUT}=V_{CC}$			± 1	μA
I_{OZL}	High Impedance Output Current (Three-State Output pins)	$V_{CC}=\text{Max.}, V_{OUT}=\text{GND}$			± 1	μA
I_{OS}	Short Circuit Current ^[7]	$V_{CC}=\text{Max.}, V_{OUT}=\text{GND}$	-60	-135	-240	mA
I_{OFF}	Power-Off Disable	$V_{CC}=0V, V_{OUT}\leq 4.5V$			± 100	μA
I_{CC}	Quiescent Power Supply Current	$V_{IN}\leq 0.2V, V_{CC}=\text{Max.}$			+40	μA
ΔI_{CC}	Quiescent Power supply Current (TTL inputs HIGH)	$V_{IN}=V_{CC}-0.6V$ ^[8] $V_{CC}=\text{Max.}$			+350	μA

Electrical Characteristics For Balanced Drive Devices Over the Operating Range $V_{CC}=2.7V$ to $3.6V$

Parameter	Description	Test Conditions	Min.	Typ. ^[5]	Max.	Unit
I_{ODL}	Output LOW Dynamic Current ^[7]	$V_{CC}=3.3V, V_{IN}=V_{IH}$ or $V_{IL}, V_{OUT}=1.5V$	45		110	mA
I_{ODH}	Output HIGH Dynamic Current ^[7]	$V_{CC}=3.3V, V_{IN}=V_{IH}$ or $V_{IL}, V_{OUT}=1.5V$	-45		-110	mA
V_{OH}	Output HIGH Voltage	$V_{CC}=\text{Min.}, I_{OH}=-0.1\text{ mA}$	$V_{CC}-0.2$			V
		$V_{CC}=\text{Min.}, I_{OH}=-8\text{ mA}$	2.4 ^[10]	3.0		V
		$V_{CC}=3.0V, I_{OH}=-24\text{ mA}$	2.0	3.0		V
V_{OL}	Output LOW Voltage	$V_{CC}=\text{Min.}, I_{OL}=0.1\text{ mA}$			0.2	V
		$V_{CC}=\text{Min.}, I_{OL}=24\text{ mA}$		0.3	0.55	

Notes:

9. Pins with bus hold are described in Pin Description.
10. $V_{OH}=V_{CC}-0.6V$ at rated current.

Capacitance^[6] ($T_A = +25^\circ\text{C}, f = 1.0\text{ MHz}$)

Parameter	Description	Test Conditions	Typ. ^[5]	Max.	Unit
C_{IN}	Input Capacitance	$V_{IN} = 0V$	4.5	6.0	pF
C_{OUT}	Output Capacitance	$V_{OUT} = 0V$	5.5	8.0	pF

Power Supply Characteristics

Parameter	Description	Test Conditions	Typ. ^[5]	Max.	Unit	
I_{CCD}	Dynamic Power Supply Current ^[11]	$V_{CC}=\text{Max.}$, One Input Toggling, 50% Duty Cycle, Outputs Open, $\overline{OE}=\text{GND}$	50	75	$\mu\text{A}/\text{MHz}$	
I_C	Total Power Supply Current ^[12]	$V_{CC}=\text{Max.}$, $f_1=10\text{ MHz}$, 50% Duty Cycle, Outputs Open, One Bit Toggling, $\overline{OE}=\text{GND}$	$V_{IN}=V_{CC}$ or $V_{IN}=\text{GND}$	0.5	0.8	mA
			$V_{IN}=V_{CC}-0.6\text{V}$ or $V_{IN}=\text{GND}$	0.5	0.8	mA
		$V_{CC}=\text{Max.}$, $f_1=2.5\text{ MHz}$, 50% Duty Cycle, Outputs Open, Sixteen Bits Toggling, $\overline{OE}=\text{GND}$	$V_{IN}=V_{CC}$ or $V_{IN}=\text{GND}$	2.0	3.0 ^[13]	mA
			$V_{IN}=V_{CC}-0.6\text{V}$ or $V_{IN}=\text{GND}$	2.0	3.3 ^[13]	mA

Switching Characteristics Over the Operating Range $V_{CC}=3.0\text{V}$ to 3.6V ^[14,15]

Parameter	Description	CY74FCT163374A CY74FCT163H374A		CY74FCT163374C CY74FCT163H374C		Unit	Fig. No. ^[16]
		Min.	Max.	Min.	Max.		
t_{PLH} t_{PHL}	Propagation Delay Clock to Output	1.5	6.5	1.5	5.2	ns	1, 3
t_{PZH} t_{PZL}	Output Enable Time	1.5	6.5	1.5	5.5	ns	1, 7, 8
t_{PHZ} t_{PLZ}	Output Disable Time	1.5	5.5	1.5	5.0	ns	1, 7, 8
t_{SU}	Input Setup time	2.0		2.0		ns	1, 4
t_H	Input Hold time	1.5	-	1.5	-	ns	1, 4
$t_{SK(O)}$	Output Skew ^[17]		0.5		0.5	ns	—

Notes:

- This parameter is not directly testable, but is derived for use in Total Power Supply calculations.
- $I_C = I_{\text{QUIESCENT}} + I_{\text{INPUTS}} + I_{\text{DYNAMIC}}$
 $I_C = I_{CC} + \Delta I_{CC} D_H N_T + I_{CCD} (f_0/2 + f_1 N_1)$
 I_{CC} = Quiescent Current with CMOS input levels
 ΔI_{CC} = Power Supply Current for a TTL HIGH input ($V_{IN}=3.4\text{V}$)
 D_H = Duty Cycle for TTL inputs HIGH
 N_T = Number of TTL inputs at D_H
 I_{CCD} = Dynamic Current caused by an input transition pair (HLH or LHL)
 f_0 = Clock frequency for registered devices, otherwise zero
 f_1 = Input signal frequency
 N_1 = Number of inputs changing at f_1
 All currents are in milliamps and all frequencies are in megahertz.
- Values for these conditions are examples of the I_{CC} formula. These limits are specified but not tested.
- Minimum limits are specified but not tested on Propagation Delays.
- For $V_{CC}=2.7$, propagation delay, output enable and output disable times should be degraded by 20%.
- See "Parameter Measurement Information" in the General Information section.
- Skew between any two outputs of the same package switching in the same direction. This parameter is ensured by design.

Switching Characteristics Over the Operating Range $V_{CC}=3.0V$ to $3.6V$ ^[14,15]

Parameter	Description	CY74FCT163LD374 ^[18] CY74FCT163LDH374		CY74FCT163LD374A ^[18] CY74FCT163LDH374A		Unit	Fig. No. ^[16]
		Min.	Max.	Min.	Max.		
t _{PLH} t _{PHL}	Propagation Delay Clock to Q Output	1.5	10	1.5	6.5	ns	1, 3
t _{PZH} t _{PZL}	Output Enable Time	1.5	12.5	1.5	6.5	ns	1, 7, 8
t _{PHZ} t _{PLZ}	Output Disable Time	1.5	8.0	1.5	5.5	ns	1, 7, 8
t _{SU}	Input Setup time	2.0		2.0		ns	1, 4
t _H	Input Hold time	1.5		1.5		ns	1, 4
t _{SK(O)}	Output Skew ^[17]		0.5		0.5	ns	—

Note:

18. For Lite Drive devices the load capacitance is 30 pF. For all others it is 50 pF.

Ordering Information CY74FCT163374

Speed (ns)	Ordering Code	Package Name	Package Type	Operating Range
5.2	CY74FCT163374CPACT	Z48	48-Lead (240-Mil) TSSOP	Industrial
	CY74FCT163374CPVC/PVCT	O48	48-Lead (300-Mil) SSOP	
6.5	CY74FCT163374APACT	Z48	48-Lead (240-Mil) TSSOP	Industrial

Ordering Information CY74FCT163H374

Speed (ns)	Ordering Code	Package Name	Package Type	Operating Range
5.2	74FCT163H374CPACT	Z48	48-Lead (240-Mil) TSSOP	Industrial
	CY74FCT163H374CPVC	O48	48-Lead (300-Mil) SSOP	
	74FCT163H374CPVCT	O48	48-Lead (300-Mil) SSOP	

Package Diagrams

48-Lead Shrunk Small Outline Package O48

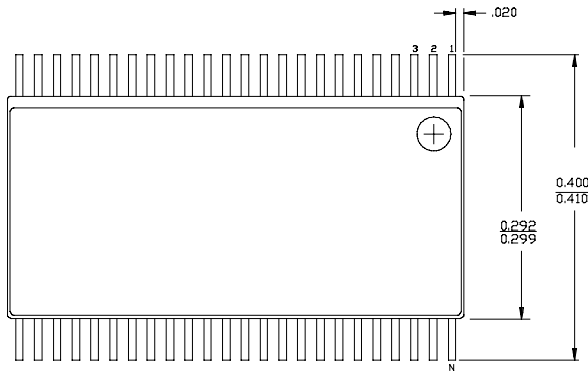

DIMENSIONS IN INCHES MIN.
MAX.

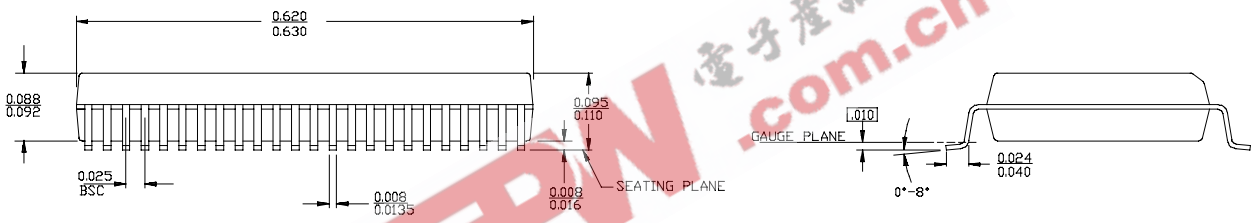

48-Lead Thin Shrunk Small Outline Package Z48

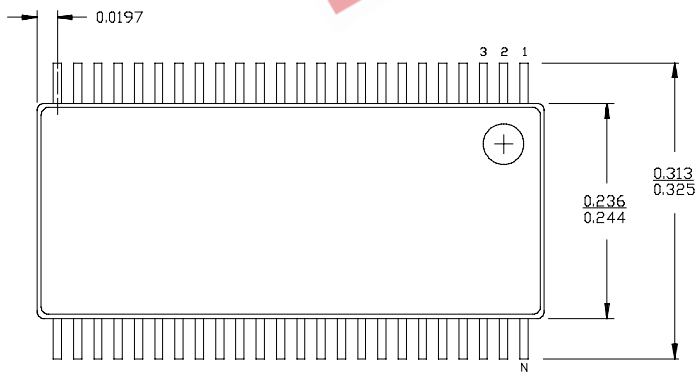

DIMENSIONS IN INCHES MIN.
MAX.

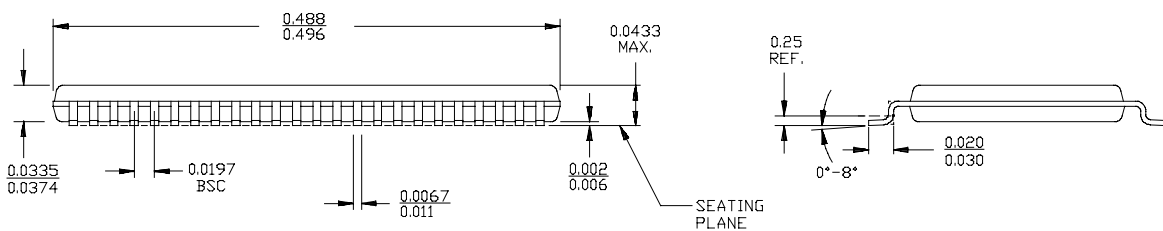

PACKAGING INFORMATION

Orderable Device	Status ⁽¹⁾	Package Type	Package Drawing	Pins	Package Qty	Eco Plan ⁽²⁾	Lead/Ball Finish	MSL Peak Temp ⁽³⁾
74FCT163H374CPACT	OBSOLETE	TSSOP	DGG	48		TBD	Call TI	Call TI
74FCT163H374CPVCT	OBSOLETE	SSOP	DL	48		TBD	Call TI	Call TI
CY74FCT163374APAC	OBSOLETE	TSSOP	DGG	48		TBD	Call TI	Call TI
CY74FCT163374APACT	OBSOLETE	TSSOP	DGG	48		TBD	Call TI	Call TI
CY74FCT163374CPAC	OBSOLETE	TSSOP	DGG	48		TBD	Call TI	Call TI
CY74FCT163374CPACT	OBSOLETE	TSSOP	DGG	48		TBD	Call TI	Call TI
CY74FCT163374CPVC	OBSOLETE	SSOP	DL	48		TBD	Call TI	Call TI
CY74FCT163374CPVCT	OBSOLETE	SSOP	DL	48		TBD	Call TI	Call TI
CY74FCT163H374CPAC	OBSOLETE	TSSOP	DGG	48		TBD	Call TI	Call TI
CY74FCT163H374CPVC	OBSOLETE	SSOP	DL	48		TBD	Call TI	Call TI

⁽¹⁾ The marketing status values are defined as follows:

ACTIVE: Product device recommended for new designs.

LIFEBUY: TI has announced that the device will be discontinued, and a lifetime-buy period is in effect.

NRND: Not recommended for new designs. Device is in production to support existing customers, but TI does not recommend using this part in a new design.

PREVIEW: Device has been announced but is not in production. Samples may or may not be available.

OBSOLETE: TI has discontinued the production of the device.

⁽²⁾ Eco Plan - The planned eco-friendly classification: Pb-Free (RoHS) or Green (RoHS & no Sb/Br) - please check <http://www.ti.com/productcontent> for the latest availability information and additional product content details.

TBD: The Pb-Free/Green conversion plan has not been defined.

Pb-Free (RoHS): TI's terms "Lead-Free" or "Pb-Free" mean semiconductor products that are compatible with the current RoHS requirements for all 6 substances, including the requirement that lead not exceed 0.1% by weight in homogeneous materials. Where designed to be soldered at high temperatures, TI Pb-Free products are suitable for use in specified lead-free processes.

Green (RoHS & no Sb/Br): TI defines "Green" to mean Pb-Free (RoHS compatible), and free of Bromine (Br) and Antimony (Sb) based flame retardants (Br or Sb do not exceed 0.1% by weight in homogeneous material)

⁽³⁾ MSL, Peak Temp. -- The Moisture Sensitivity Level rating according to the JEDEC industry standard classifications, and peak solder temperature.

Important Information and Disclaimer:The information provided on this page represents TI's knowledge and belief as of the date that it is provided. TI bases its knowledge and belief on information provided by third parties, and makes no representation or warranty as to the accuracy of such information. Efforts are underway to better integrate information from third parties. TI has taken and continues to take reasonable steps to provide representative and accurate information but may not have conducted destructive testing or chemical analysis on incoming materials and chemicals. TI and TI suppliers consider certain information to be proprietary, and thus CAS numbers and other limited information may not be available for release.

In no event shall TI's liability arising out of such information exceed the total purchase price of the TI part(s) at issue in this document sold by TI to Customer on an annual basis.

MECHANICAL DATA

MSS0001C – JANUARY 1995 – REVISED DECEMBER 2001

DL (R-PDSO-G**)

PLASTIC SMALL-OUTLINE PACKAGE

48 PINS SHOWN

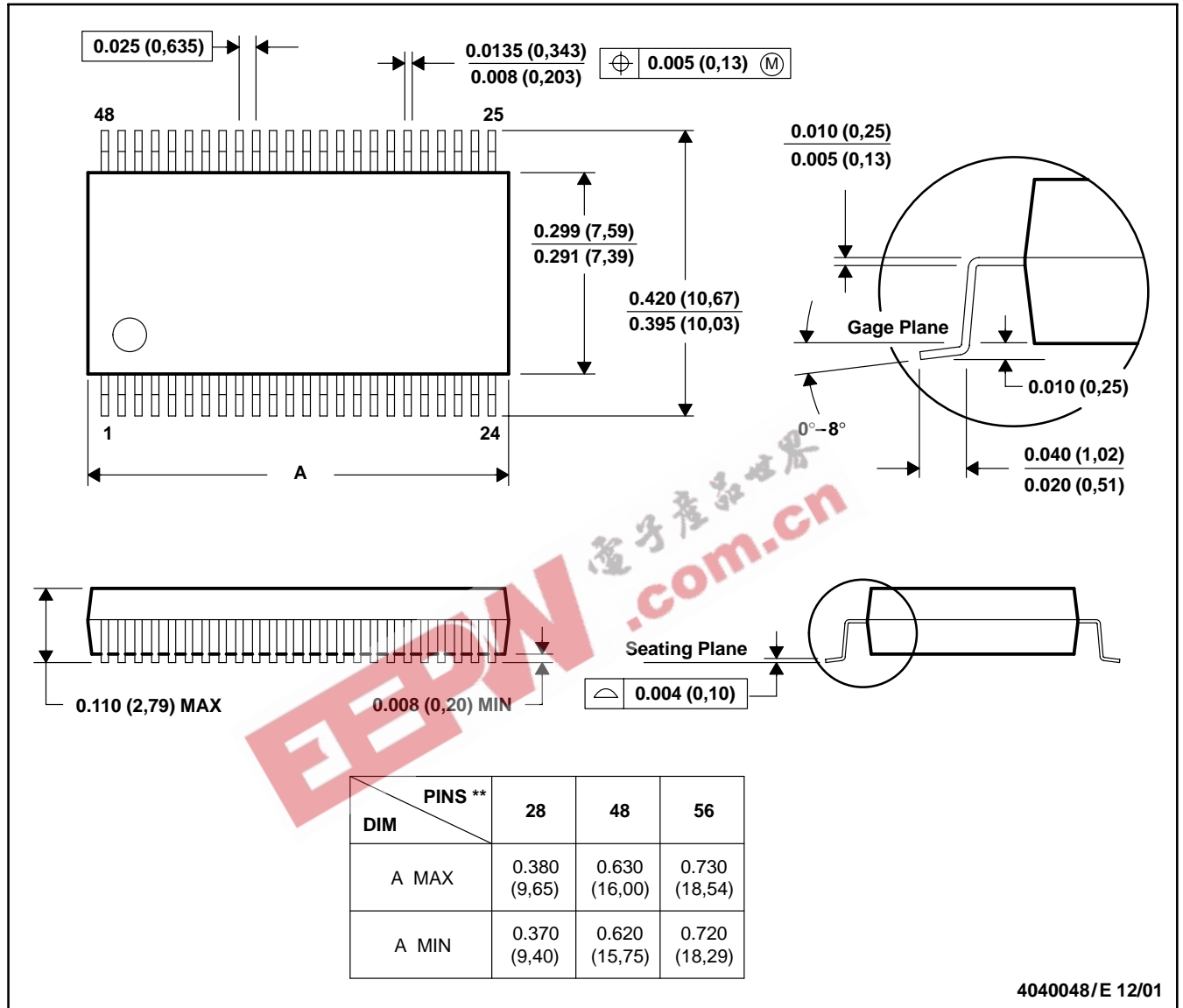

- NOTES: A. All linear dimensions are in inches (millimeters).
 B. This drawing is subject to change without notice.
 C. Body dimensions do not include mold flash or protrusion not to exceed 0.006 (0,15).
 D. Falls within JEDEC MO-118

MECHANICAL DATA

MTSS003D – JANUARY 1995 – REVISED JANUARY 1998

DGG (R-PDSO-G**)

PLASTIC SMALL-OUTLINE PACKAGE

48 PINS SHOWN

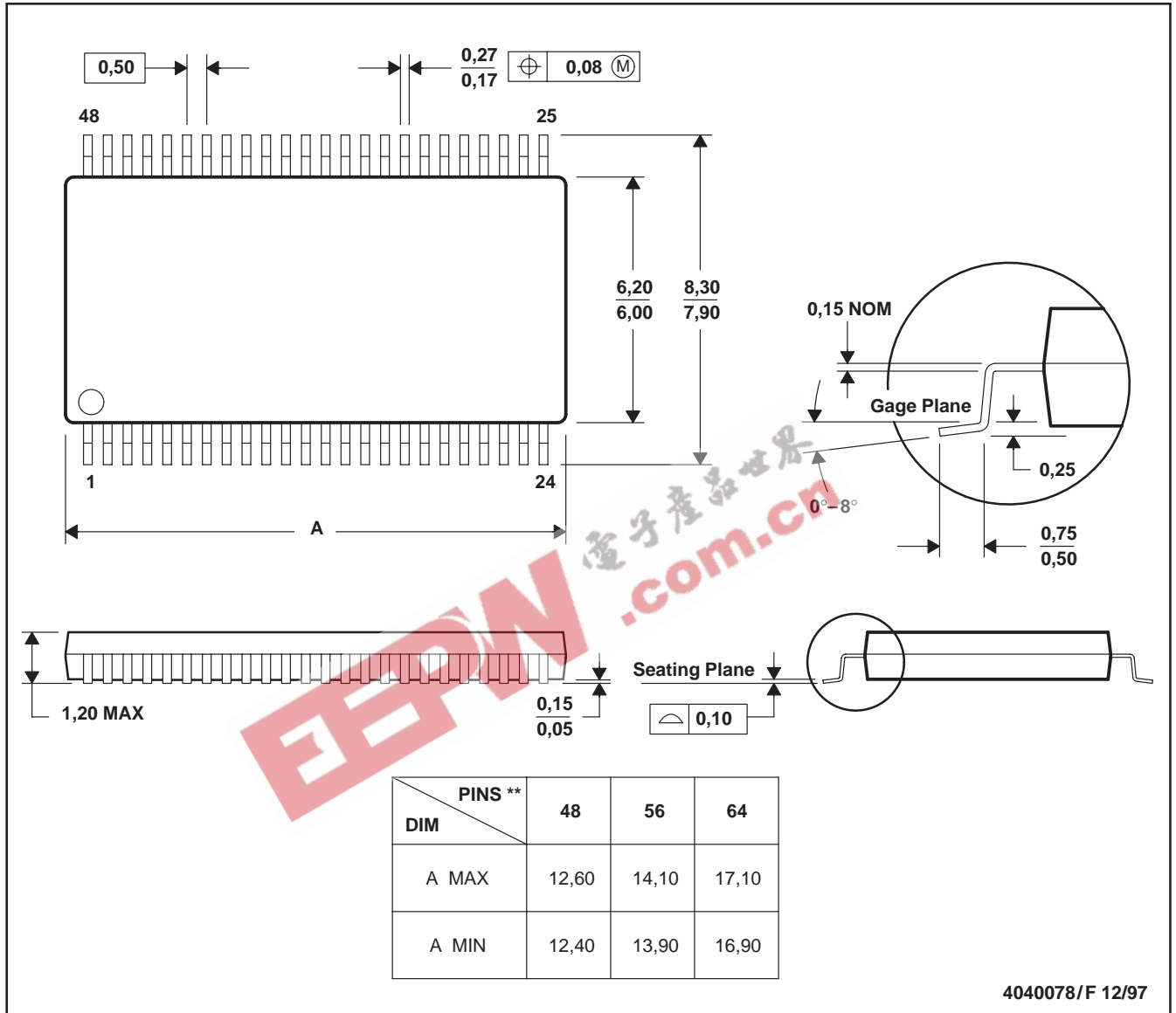

- NOTES: A. All linear dimensions are in millimeters.
 B. This drawing is subject to change without notice.
 C. Body dimensions do not include mold protrusion not to exceed 0,15.
 D. Falls within JEDEC MO-153

IMPORTANT NOTICE

Texas Instruments Incorporated and its subsidiaries (TI) reserve the right to make corrections, modifications, enhancements, improvements, and other changes to its products and services at any time and to discontinue any product or service without notice. Customers should obtain the latest relevant information before placing orders and should verify that such information is current and complete. All products are sold subject to TI's terms and conditions of sale supplied at the time of order acknowledgment.

TI warrants performance of its hardware products to the specifications applicable at the time of sale in accordance with TI's standard warranty. Testing and other quality control techniques are used to the extent TI deems necessary to support this warranty. Except where mandated by government requirements, testing of all parameters of each product is not necessarily performed.

TI assumes no liability for applications assistance or customer product design. Customers are responsible for their products and applications using TI components. To minimize the risks associated with customer products and applications, customers should provide adequate design and operating safeguards.

TI does not warrant or represent that any license, either express or implied, is granted under any TI patent right, copyright, mask work right, or other TI intellectual property right relating to any combination, machine, or process in which TI products or services are used. Information published by TI regarding third-party products or services does not constitute a license from TI to use such products or services or a warranty or endorsement thereof. Use of such information may require a license from a third party under the patents or other intellectual property of the third party, or a license from TI under the patents or other intellectual property of TI.

Reproduction of information in TI data books or data sheets is permissible only if reproduction is without alteration and is accompanied by all associated warranties, conditions, limitations, and notices. Reproduction of this information with alteration is an unfair and deceptive business practice. TI is not responsible or liable for such altered documentation.

Resale of TI products or services with statements different from or beyond the parameters stated by TI for that product or service voids all express and any implied warranties for the associated TI product or service and is an unfair and deceptive business practice. TI is not responsible or liable for any such statements.

Following are URLs where you can obtain information on other Texas Instruments products and application solutions:

Products		Applications	
Amplifiers	amplifier.ti.com	Audio	www.ti.com/audio
Data Converters	dataconverter.ti.com	Automotive	www.ti.com/automotive
DSP	dsp.ti.com	Broadband	www.ti.com/broadband
Interface	interface.ti.com	Digital Control	www.ti.com/digitalcontrol
Logic	logic.ti.com	Military	www.ti.com/military
Power Mgmt	power.ti.com	Optical Networking	www.ti.com/opticalnetwork
Microcontrollers	microcontroller.ti.com	Security	www.ti.com/security
		Telephony	www.ti.com/telephony
		Video & Imaging	www.ti.com/video
		Wireless	www.ti.com/wireless

Mailing Address: Texas Instruments
Post Office Box 655303 Dallas, Texas 75265