



New Product

GS1117

Vishay Semiconductors
formerly General Semiconductor

800mA Low Dropout Positive Adjustable Regulator

SOT-223

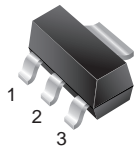

GS1117CST

TO-252
(DPak)

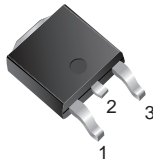

GS1117CE

TO-220AB

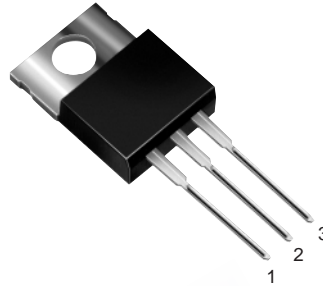

GS1117CT

TO-263AB
(D²Pak)

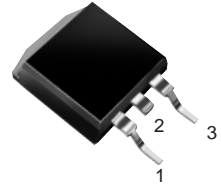

GS1117CM

Pin Definition

1. Adjust/Gnd.
2. V_{out} (tab)
3. V_{in}

Features

- Dropout Voltage 1.2V at 800mA Output Current
- Fast Transient Response
- Line Regulation typically at 0.015%
- Load Regulation typically at 0.1%
- Internal thermal limiting
- Adjustable Output Voltage or Fixed 2.5V, 2.85V, 3.3V, 5V
- Standard 3-Pin Power Packages

Functional Block Diagram

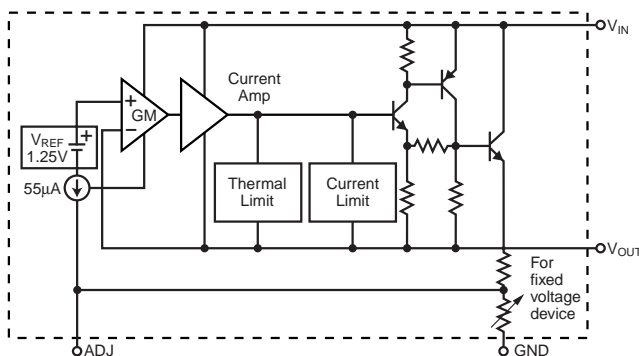

Description

The GS1117 is a low dropout three terminal regulator with 800mA output current capability. The output voltage is adjustable with the use of a resistor divider. For fixed output voltage versions, the output voltage is internally set at 2.5V, 2.85V, 3.3V or 5V. Dropout is guaranteed at a maximum of 1.4V at maximum output current. Its low dropout voltage and fast transient response make it ideal for low voltage microprocessor applications. Internal thermal limiting provides protection against any overload condition that would create excessive junction temperatures.

Applications

- SCSI-2 Active Terminator
- Post Regulator for Switching Supply
- Battery Chargers
- Constant-Current Regulators
- PC Add-On Card

Mechanical Data

Case: TO-220AB, TO-263AB (D²PAK), TO-252 (DPAK) and SOT-223

High temperature soldering guaranteed:
260°C/10 seconds at terminals

Case outlines are on the back page



Maximum Ratings and Thermal Characteristics (T_A = 25°C unless otherwise noted)

Parameter	Symbol	Value	Unit
Vin Pin to ADJ/GND Pin	V _{in}	7	V
Thermal Resistance – Junction to Case	R _{θJC}	3.0	°C/W
TO-220AB		8.0	
TO-252		3.0	
TO-263AB SOT-223		15.0	
Operating Junction Temperature Range	T _J	0 to +125	°C
Storage Temperature Range	T _{stg}	-65 to 150	°C

Electrical Characteristics ⁽¹⁾ T_J = 25°C ⁽²⁾ V_{IN} = 5V, I_o = 10mA unless otherwise noted.

Parameter	Symbol	Test Conditions	Min	Typ	Max	Unit
Reference Voltage	V _{REF}	T _J = 25°C	1.238	1.250	1.262	V
		0°C ≤ T _J ≤ 125°C 2.65V ≤ V _{IN} ≤ 7V 10mA ≤ I _o ≤ 800mA	1.225	1.250	1.275	V
Output Voltage	V _{OUT}	GS1117-2.5, V _{IN} = 5V	2.48	2.5	2.53	V
		GS1117-2.85, V _{IN} = 5V	2.82	2.85	2.88	V
		GS1117-3.3, V _{IN} = 5V	3.26	3.30	3.33	V
		GS1117-5, V _{IN} = 7V	4.95	5.00	5.05	V
		GS1117	0.98V _N	V _N	1.02V _N	V
Line Regulation	REG _{line}	2.65V ≤ V _{IN} ≤ 7V T _J = 25°C		0.015	0.2	% V _O
		0°C ≤ T _J ≤ 125°C		0.02	0.2	% V _O
Load Regulation	REG _{load}	10mA ≤ I _o ≤ 800mA T _J = 25°C		0.1	0.3	% V _O
		0°C ≤ T _J ≤ 125°C		0.2	0.4	% V _O
Dropout Voltage	V _{DROP}	0°C ≤ T _J ≤ 125°C		1.2	1.4	V
		I _o = 800mA		1.19	1.35	V
		I _o = 500mA I _o = 100mA		1.15	1.30	V

Notes:

(1) All parameters, except nominal output voltage are specified for the variable voltage version, allowing a wider V_{in} Range.

The specified limits also apply for the fixed voltage versions over the allowable input voltage range: GS1117-2.5 (3.9V - 7.0V), GS1117-2.85 (4.25V - 7.0V), GS1117 - 3.3 (4.75V - 7.0V), GS1117-5 (6.4V - 7.0V).

(2) To maintain the specified junction temperatures, low duty cycle pulse testing is required for most parameters.

Electrical Characteristics⁽¹⁾ $T_J = 25^\circ\text{C}$ ⁽²⁾, $V_{IN} = 5\text{V}$, $I_o = 10\text{mA}$ unless otherwise noted.

Parameter	Symbol	Test Conditions	Min	Typ	Max	Unit
Output Current	I_o	$0^\circ\text{C} \leq T_J \leq 125^\circ\text{C}$	0.85			A
Adjust Pin Current	I_{adj}	$2.65 \leq V_{in} \leq 7\text{V}$ $10\text{mA} \leq I_o \leq 800\text{mA}$ $0^\circ\text{C} \leq T_J \leq 125^\circ\text{C}$		55	120	μA
Adjust Pin Current Change	ΔI_{adj}	$2.65 \leq V_{in} \leq 7\text{V}$ $10\text{mA} \leq I_o \leq 800\text{mA}$ $0^\circ\text{C} \leq T_J \leq 125^\circ\text{C}$		0.2	5	μA
Temperature Stability	T_S	$I_o = 0.5\text{A}$ $0^\circ\text{C} \leq T_J \leq 125^\circ\text{C}$		0.8		% V_O
Minimum Load Current Adjustable Version	I_{LMIN}	$0^\circ\text{C} \leq T_J \leq 125^\circ\text{C}$		3	10	mA
Quiescent Current Fixed Voltage Version	I_Q	$0^\circ\text{C} \leq T_J \leq 125^\circ\text{C}$		10	14	mA
RMS Output Noise	N	$10\text{Hz} \leq f \leq 10\text{kHz}$		0.003		% V_O
Ripple Rejection Ratio	RR	$f = 120\text{Hz}$, $C_o = 25\mu\text{F}$ $C_{adj} = 25\mu\text{F}$	60	68		dB
Thermal Regulation	R_{TH}	$T_A = 25^\circ\text{C}$, 30ms Pulse		0.02	0.05	%/W
Long Term Stability		$T_A = 125^\circ\text{C}$, 1000 Hrs		0.3		% V_O

Notes:

- (1) All parameters, except nominal output voltage are specified for the variable voltage version, allowing a wider V_{in} Range. The specified limits also apply for the fixed voltage versions.
- (2) To maintain the specified junction temperatures, low duty cycle pulse testing is required for most parameters.

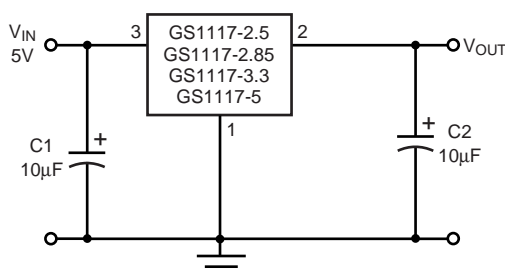
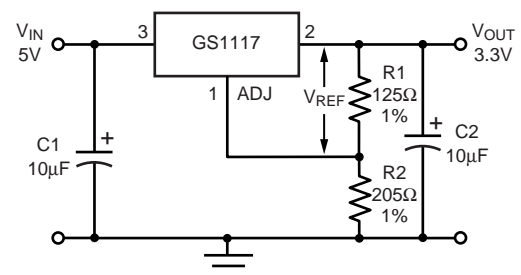
Typical Application Circuit

Fixed Voltage Regulator

Adjustable Voltage Regulator
Notes:

$$V_{REF} = V_{OUT} - V_{ADJ} = 1.25\text{V (typ.)}$$

$$V_{OUT} = V_{REF} \times (1 + R2/R1) + I_{ADJ} \times R2$$

$$I_{ADJ} = 55\mu\text{A (typ.)}$$

(1) C1 needed if device is far away from filter capacitors

(2) C2 required for stability

Ratings and Characteristic Curves ($T_A = 25^\circ\text{C}$ unless otherwise noted)

Fig. 1 – Dropout Voltage

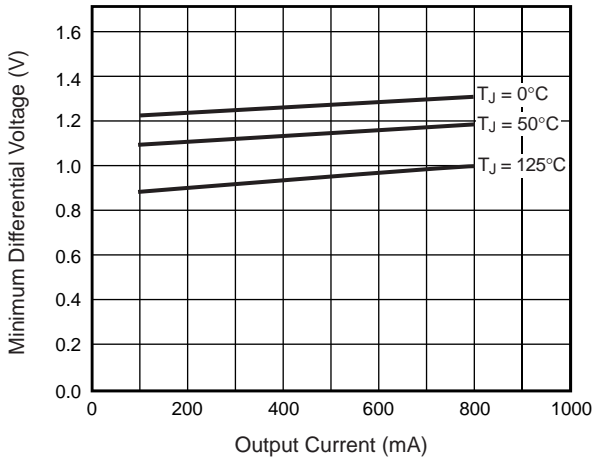

Fig. 2 – Dropout Voltage v.s. Temperature

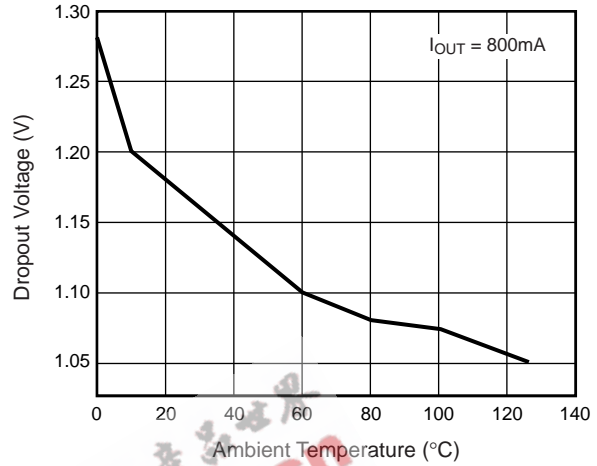

Fig. 3 – Minimum Load Current (Adjustable Version)

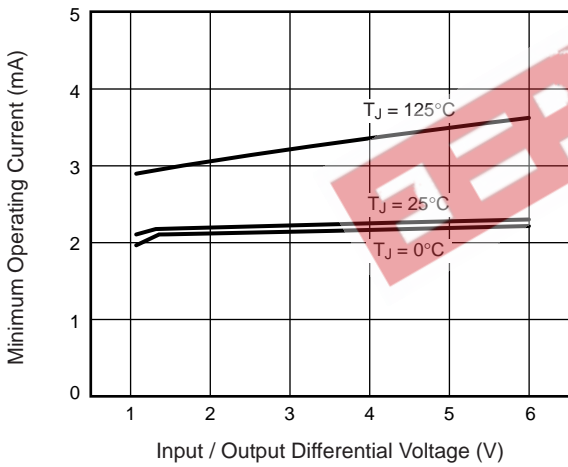

Fig. 4 – Adjust Pin Current

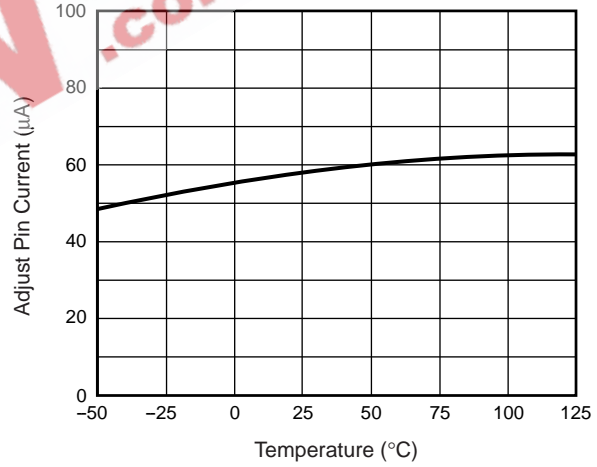

Fig. 5 – Temperature Stability

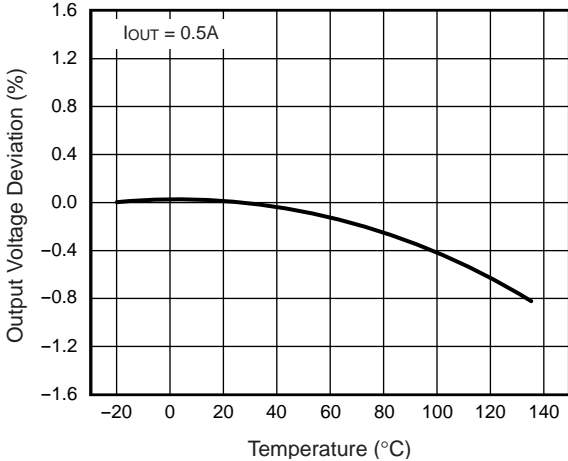
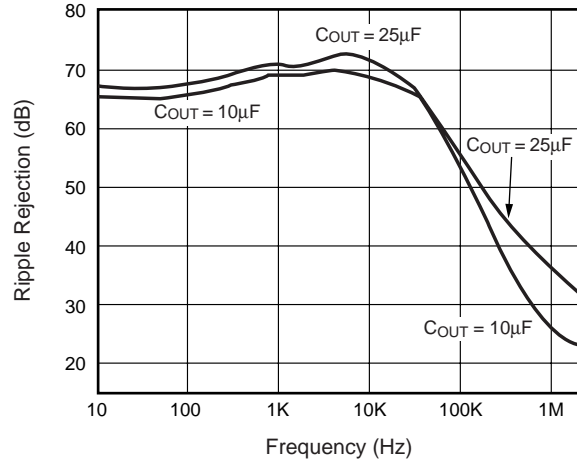

Fig. 6 – Ripple Rejection (with $C_{adj} 25\mu\text{F}$)





Ratings and Characteristic Curves ($T_A = 25^\circ\text{C}$ unless otherwise noted)

Fig. 7 – Load Transient Response

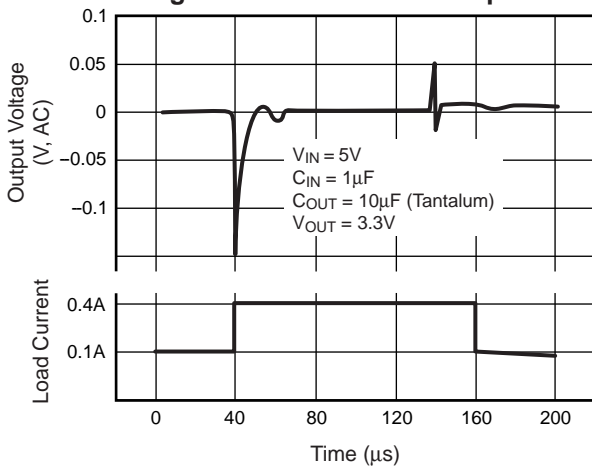
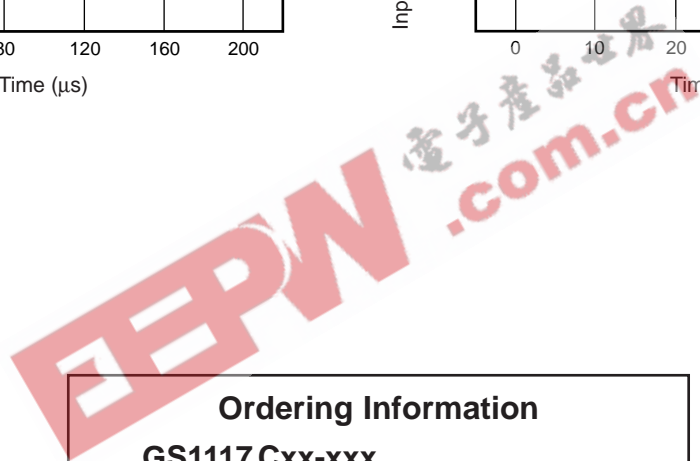
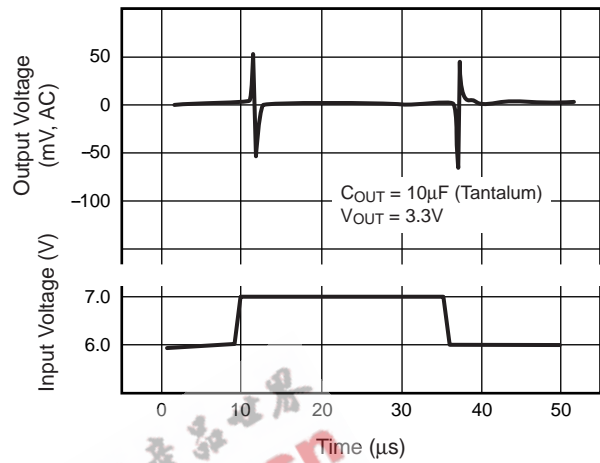

Fig. 8 – Line Transient Response



Ordering Information

GS1117 Cxx-xxx

- Output Voltage
Default: Adj.
2.5: 2.5V
2.85: 2.85V
3.3: 3.3V
5: 5.0V
- Package Type
ST: SOT-223
T: TO-220
M: TO-263
E: TO-252

Case Outlines

SOT-223

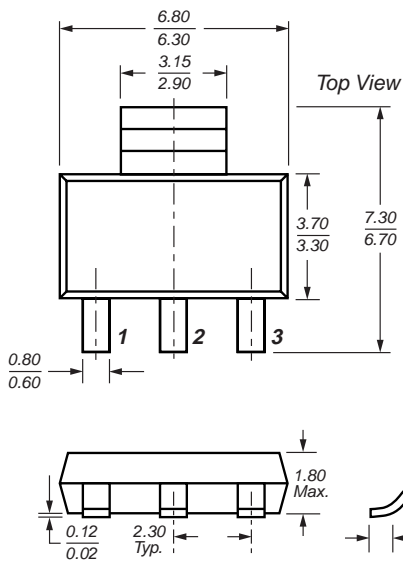

TO-252 (DPAK)

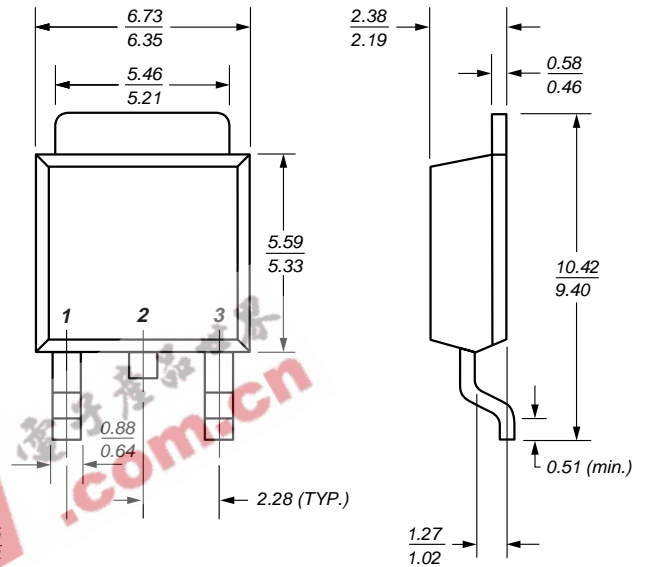

Dimensions in millimeters

TO-263

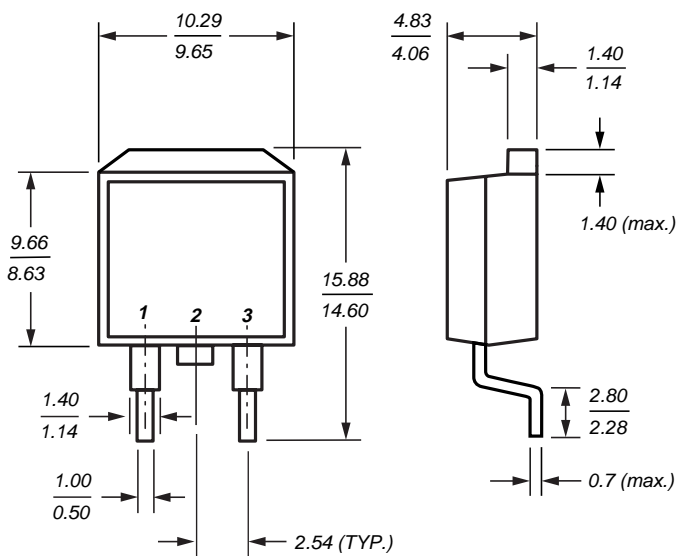

TO-220

