

## 54LS245/DM54LS245/DM74LS245 TRI-STATE® Octal Bus Transceiver

### General Description

These octal bus transceivers are designed for asynchronous two-way communication between data buses. The control function implementation minimizes external timing requirements.

The device allows data transmission from the A bus to the B bus or from the B bus to the A bus depending upon the logic level at the direction control (DIR) input. The enable input ( $\bar{G}$ ) can be used to disable the device so that the buses are effectively isolated.

- PNP inputs reduce DC loading on bus lines
- Hysteresis at bus inputs improve noise margins
- Typical propagation delay times, port-to-port 8 ns
- Typical enable/disable times 17 ns

- $I_{OL}$  (sink current)
  - 54LS 12 mA
  - 74LS 24 mA
- $I_{OH}$  (source current)
  - 54LS -12 mA
  - 74LS -15 mA

- Alternate Military/Aerospace device (54LS245) is available. Contact a National Semiconductor Sales Office/Distributor for specifications.

### Features

- Bi-Directional bus transceiver in a high-density 20-pin package
- TRI-STATE outputs drive bus lines directly

### Connection Diagram

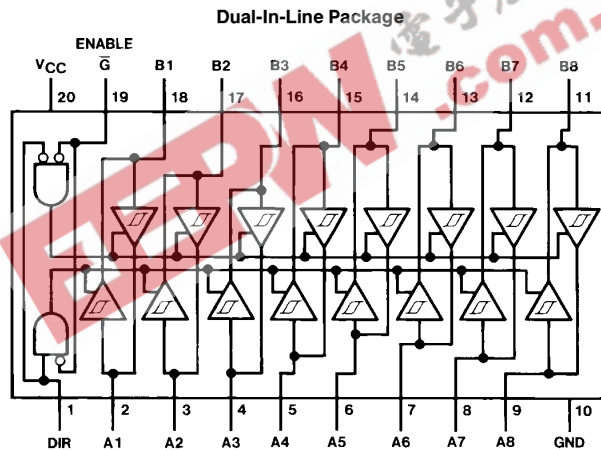

TL/F/6413-1

Order Number 54LS245DMQB, 54LS245FMQB, 54LS245LMQB,  
DM54LS245J, DM54LS245W, DM74LS245WM or DM74LS245N  
See NS Package Number E20A, J20A, M20B, N20A or W20A

### Function Table

Enable $\bar{G}$	Direction Control DIR	Operation
L	L	B data to A bus
L	H	A data to B bus
H	X	Isolation

H = High Level, L = Low Level, X = Irrelevant

TRI-STATE® is a registered trademark of National Semiconductor Corporation.

## Absolute Maximum Ratings (Note)

If Military/Aerospace specified devices are required, please contact the National Semiconductor Sales Office/Distributors for availability and specifications.

Supply Voltage	7V
Input Voltage	
DIR or $\bar{G}$	7V
A or B	5.5V
Operating Free Air Temperature Range	
DM54LS and 54LS	-55°C to +125°C
DM74LS	0°C to +70°C
Storage Temperature Range	-65°C to +150°C

Note: The "Absolute Maximum Ratings" are those values beyond which the safety of the device cannot be guaranteed. The device should not be operated at these limits. The parametric values defined in the "Electrical Characteristics" table are not guaranteed at the absolute maximum ratings. The "Recommended Operating Conditions" table will define the conditions for actual device operation.

## Recommended Operating Conditions

Symbol	Parameter	DM54LS245			DM74LS245			Units
		Min	Nom	Max	Min	Nom	Max	
V <sub>CC</sub>	Supply Voltage	4.5	5	5.5	4.75	5	5.25	V
V <sub>IH</sub>	High Level Input Voltage	2			2			V
V <sub>IL</sub>	Low Level Input Voltage			0.7			0.8	V
I <sub>OH</sub>	High Level Output Current			-12			-15	mA
I <sub>OL</sub>	Low Level Output Current			12			24	mA
T <sub>A</sub>	Free Air Operating Temperature	-55		125	0		70	°C

## Electrical Characteristics over recommended operating free air temperature range (unless otherwise noted)

Symbol	Parameter	Conditions	Min	Typ (Note 1)	Max	Units		
V <sub>I</sub>	Input Clamp Voltage	V <sub>CC</sub> = Min, I <sub>I</sub> = -18 mA			-1.5	V		
HYS	Hysteresis (V <sub>T+</sub> - V <sub>T-</sub> )	V <sub>CC</sub> = Min	0.2	0.4		V		
V <sub>OH</sub>	High Level Output Voltage	V <sub>CC</sub> = Min, V <sub>IH</sub> = Min V <sub>IL</sub> = Max, I <sub>OH</sub> = -1 mA	DM74	2.7		V		
		V <sub>CC</sub> = Min, V <sub>IL</sub> = Min V <sub>IL</sub> = Max, I <sub>OH</sub> = -3 mA	DM54/DM74	2.4	3.4			
		V <sub>CC</sub> = Min, V <sub>IH</sub> = Min V <sub>IL</sub> = 0.5V, I <sub>OH</sub> = Max	DM54/DM74	2				
V <sub>OL</sub>	Low Level Output Voltage	V <sub>CC</sub> = Min V <sub>IL</sub> = Max V <sub>IH</sub> = Min	I <sub>OL</sub> = 12 mA	DM74		0.4		
			I <sub>OL</sub> = Max	DM54		0.4		
				DM74		0.5		
I <sub>OZH</sub>	Off-State Output Current, High Level Voltage Applied	V <sub>CC</sub> = Max V <sub>IL</sub> = Max V <sub>IH</sub> = Min	V <sub>O</sub> = 2.7V			20	μA	
I <sub>OZL</sub>	Off-State Output Current, Low Level Voltage Applied		V <sub>O</sub> = 0.4V			-200	μA	
I <sub>I</sub>	Input Current at Maximum Input Voltage	V <sub>CC</sub> = Max	A or B	V <sub>I</sub> = 5.5V		0.1	mA	
			DIR or $\bar{G}$	V <sub>I</sub> = 7V		0.1		
I <sub>IH</sub>	High Level Input Current	V <sub>CC</sub> = Max, V <sub>I</sub> = 2.7V				20	μA	
I <sub>IL</sub>	Low Level Input Current	V <sub>CC</sub> = Max, V <sub>I</sub> = 0.4V				-0.2	mA	
I <sub>OS</sub>	Short Circuit Output Current	V <sub>CC</sub> = Max (Note 2)			-40	-225	mA	
I <sub>CC</sub>	Supply Current	Outputs High	V <sub>CC</sub> = Max		48	70	mA	
				Outputs Low		62		90
				Outputs at Hi-Z		64		95

Note 1: All typicals are at V<sub>CC</sub> = 5V, T<sub>A</sub> = 25°C.

Note 2: Not more than one output should be shorted at a time, not to exceed one second duration

**Switching Characteristics**  $V_{CC} = 5V$ ,  $T_A = 25^\circ C$  (See Section 1 for Test Waveforms and Output Load)

Symbol	Parameter	Conditions	DM54/74		Units
			LS245		
			Min	Max	
$t_{PLH}$	Propagation Delay Time, Low-to-High-Level Output	$C_L = 45 \text{ pF}$ $R_L = 667\Omega$		12	ns
$t_{PHL}$	Propagation Delay Time, High-to-Low-Level Output			12	ns
$t_{PZL}$	Output Enable Time to Low Level			40	ns
$t_{PZH}$	Output Enable Time to High Level			40	ns
$t_{PLZ}$	Output Disable Time from Low Level	$C_L = 5 \text{ pF}$ $R_L = 667\Omega$		25	ns
$t_{PHZ}$	Output Disable Time from High Level			25	ns
$t_{PLH}$	Propagation Delay Time, Low-to-High-Level Output	$C_L = 150 \text{ pF}$ $R_L = 667\Omega$		16	ns
$t_{PHL}$	Propagation Delay Time, High-to-Low-Level Output			17	ns
$t_{PZL}$	Output Enable Time to Low Level			45	ns
$t_{PZH}$	Output Enable Time to High Level			45	ns

EEPW 电子產品世界  
.com.cn

**Physical Dimensions** inches (millimeters)

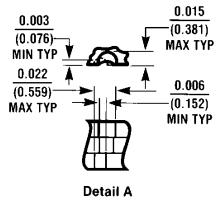
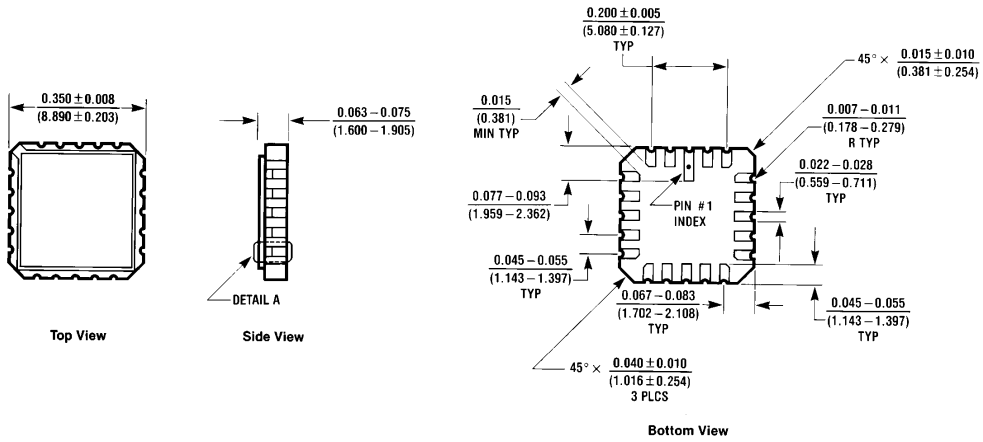

**Ceramic Leadless Chip Carrier Package (E)**  
**Order Number 54LS245LMQB**  
**NS Package Number E20A**

E20A (REV D)

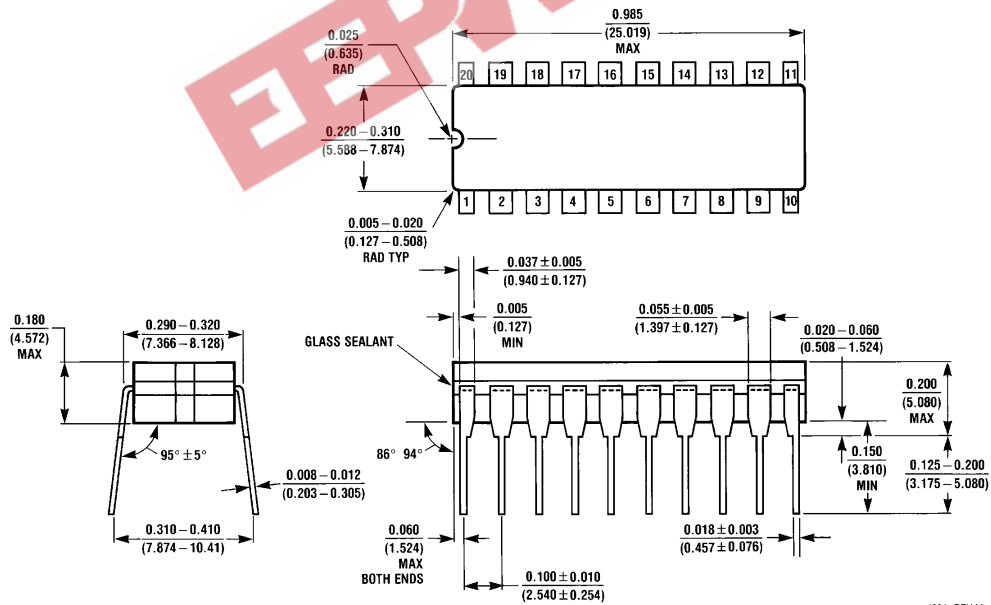

**20-Lead Ceramic Dual-In-Line Package (J)**  
**Order Number 54LS245DMQB or DM54LS245J**  
**NS Package Number J20A**

J20A (REV M)

**Physical Dimensions** inches (millimeters) (Continued)

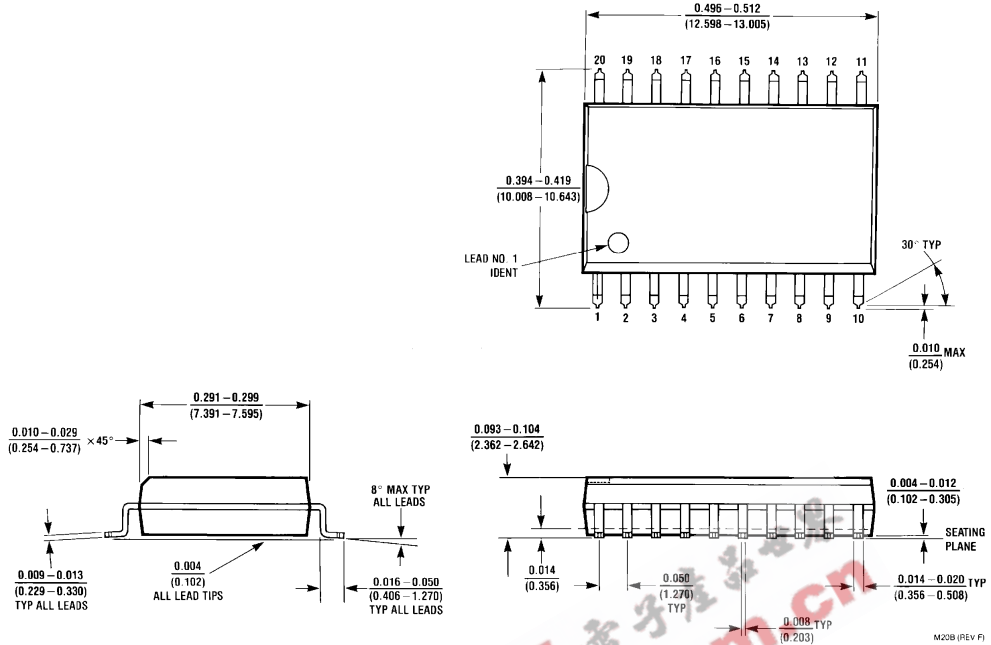

**20-Lead Small Outline Molded Package (M)**  
**Order Number DM74LS245WM**  
**NS Package Number M20B**

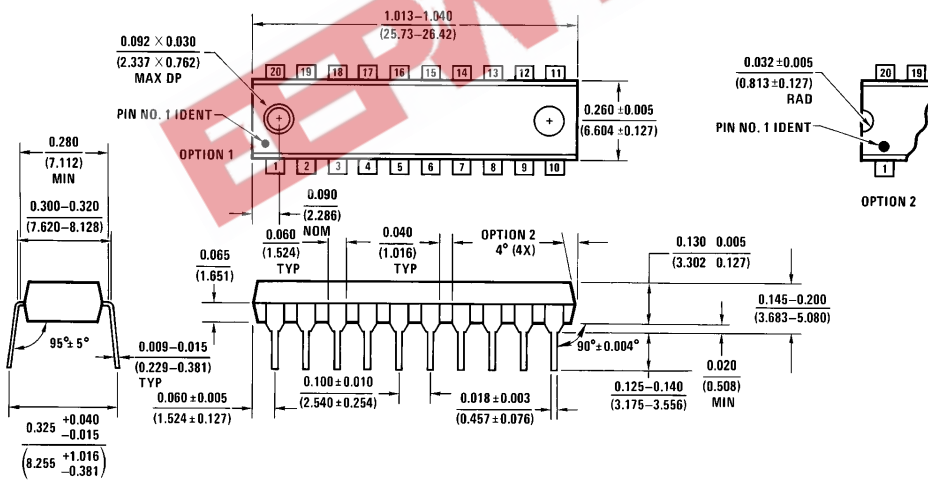

**20-Lead Molded Dual-In-Line Package (N)**  
**Order Number DM74LS245N**  
**NS Package Number N20A**

**Physical Dimensions** inches (millimeters) (Continued)

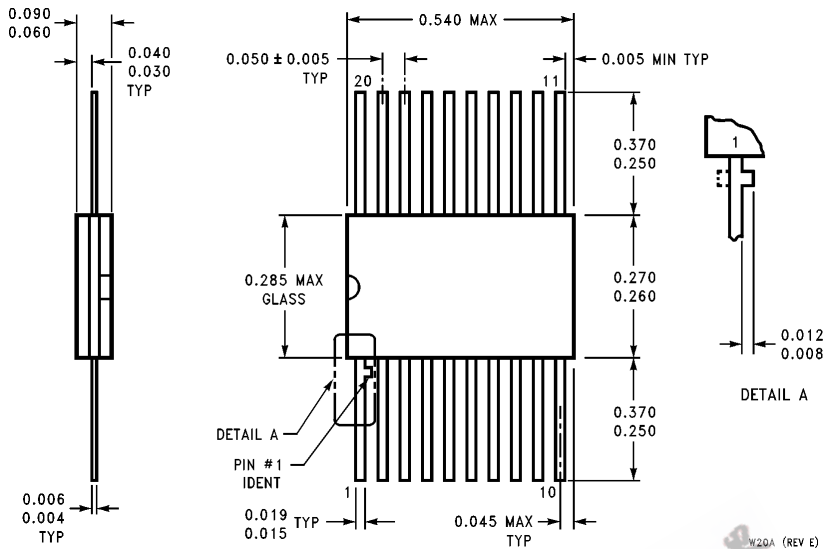

**20-Lead Ceramic Flat Package (W)**  
**Order Number 54LS245FMQB or DM54LS245W**  
**NS Package Number W20A**

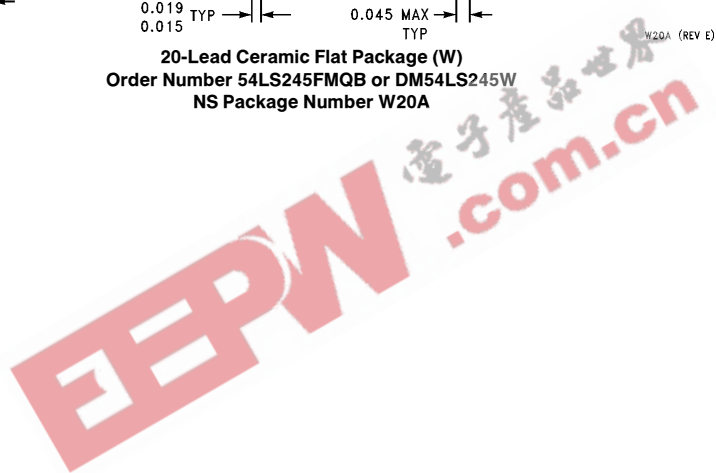

**LIFE SUPPORT POLICY**

NATIONAL'S PRODUCTS ARE NOT AUTHORIZED FOR USE AS CRITICAL COMPONENTS IN LIFE SUPPORT DEVICES OR SYSTEMS WITHOUT THE EXPRESS WRITTEN APPROVAL OF THE PRESIDENT OF NATIONAL SEMICONDUCTOR CORPORATION. As used herein:

1. Life support devices or systems are devices or systems which, (a) are intended for surgical implant into the body, or (b) support or sustain life, and whose failure to perform, when properly used in accordance with instructions for use provided in the labeling, can be reasonably expected to result in a significant injury to the user.
2. A critical component is any component of a life support device or system whose failure to perform can be reasonably expected to cause the failure of the life support device or system, or to affect its safety or effectiveness.



**National Semiconductor Corporation**  
 1111 West Bardin Road  
 Arlington, TX 76017  
 Tel: 1(800) 272-9959  
 Fax: 1(800) 737-7018

**National Semiconductor Europe**  
 Fax: (+49) 0-180-530 85 86  
 Email: cnjwge@levm2.nsc.com  
 Deutsch Tel: (+49) 0-180-530 85 85  
 English Tel: (+49) 0-180-532 78 32  
 Français Tel: (+49) 0-180-532 93 58  
 Italiano Tel: (+49) 0-180-534 16 80

**National Semiconductor Hong Kong Ltd.**  
 13th Floor, Straight Block,  
 Ocean Centre, 5 Canton Rd.  
 Tsimshatsui, Kowloon  
 Hong Kong  
 Tel: (852) 2737-1600  
 Fax: (852) 2736-9960

**National Semiconductor Japan Ltd.**  
 Tel: 81-043-299-2309  
 Fax: 81-043-299-2408

National does not assume any responsibility for use of any circuitry described, no circuit patent licenses are implied and National reserves the right at any time without notice to change said circuitry and specifications.