



Integrated Device Technology, Inc.

FAST CMOS OCTAL BUFFER/LINE DRIVERS

IDT54/74FCT240T/AT/CT/DT - 2240T/AT/CT
IDT54/74FCT244T/AT/CT/DT - 2244T/AT/CT
IDT54/74FCT540T/AT/CT
IDT54/74FCT541/2541T/AT/CT

FEATURES:

• Common features:

- Low input and output leakage $\leq 1\mu\text{A}$ (max.)
- CMOS power levels
- True TTL input and output compatibility
 - $V_{OH} = 3.3\text{V}$ (typ.)
 - $V_{OL} = 0.3\text{V}$ (typ.)
- Meets or exceeds JEDEC standard 18 specifications
- Product available in Radiation Tolerant and Radiation Enhanced versions
- Military product compliant to MIL-STD-883, Class B and DESC listed (dual marked)
- Available in DIP, SOIC, SSOP, QSOP, CERPACK and LCC packages

• Features for FCT240T/FCT244T/FCT540T/FCT541T:

- Std., A, C and D speed grades
- High drive outputs (-15mA IOH, 64mA IOL)

• Features for FCT2240T/FCT2244T/FCT2541T:

- Std., A and C speed grades
- Resistor outputs (-15mA IOH, 12mA IOL Com.)
(-12mA IOH, 12mA IOL Mil.)
- Reduced system switching noise

DESCRIPTION:

The IDT octal buffer/line drivers are built using an advanced dual metal CMOS technology. The FCT240T/FCT2240T and FCT244T/FCT2244T are designed to be employed as memory and address drivers, clock drivers and bus-oriented transmitter/receivers which provide improved board density.

The FCT540T and FCT541T/FCT2541T are similar in function to the FCT240T/FCT2240T and FCT244T/FCT2244T, respectively, except that the inputs and outputs are on opposite sides of the package. This pinout arrangement makes these devices especially useful as output ports for microprocessors and as backplane drivers, allowing ease of layout and greater board density.

The FCT2240T, FCT2244T and FCT2541T have balanced output drive with current limiting resistors. This offers low ground bounce, minimal undershoot and controlled output fall times-reducing the need for external series terminating resistors. FCT2xxxT parts are plug-in replacements for FCTxxxT parts.

FUNCTIONAL BLOCK DIAGRAMS

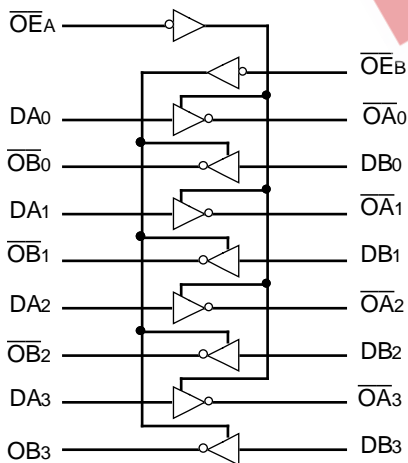

FCT240/2240T

2565 drw 01

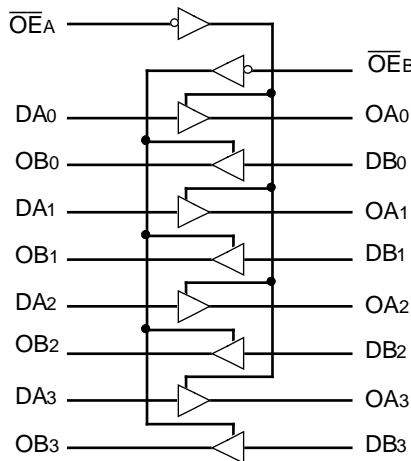

FCT244/2244T

2565 drw 02

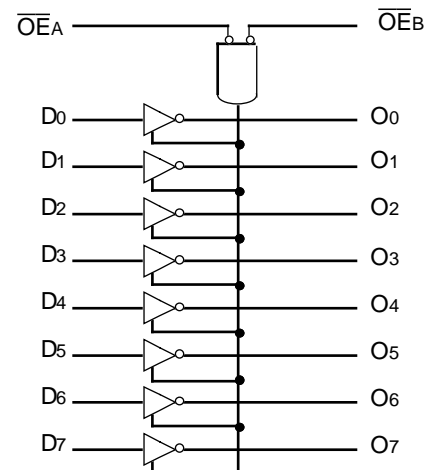

FCT540/541/2541T

2565 drw 03

*Logic diagram shown for 'FCT540.
'FCT541/2541T is the non-inverting option.

The IDT logo is a registered trademark of Integrated Device Technology, Inc.

MILITARY AND COMMERCIAL TEMPERATURE RANGES

DECEMBER 1995

PIN CONFIGURATIONS

FCT240/2240T

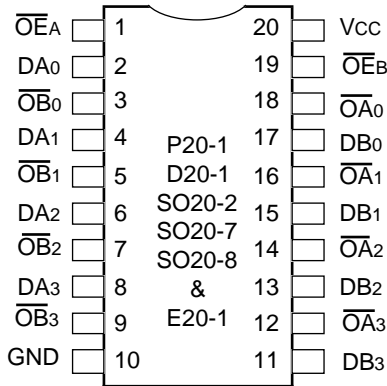

**DIP/SOIC/SSOP/QSOP/CERPACK
 TOP VIEW**

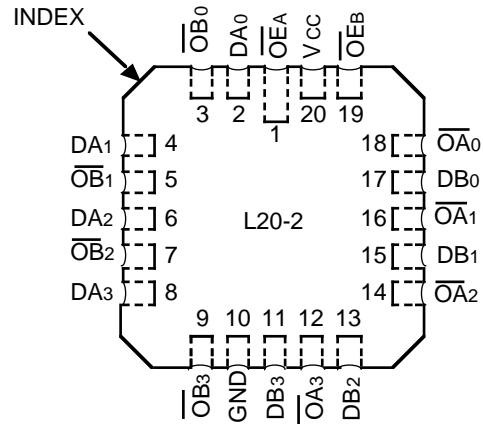

**LCC
 TOP VIEW**

2565 drw 04

2565 drw 07

FCT244/2244T

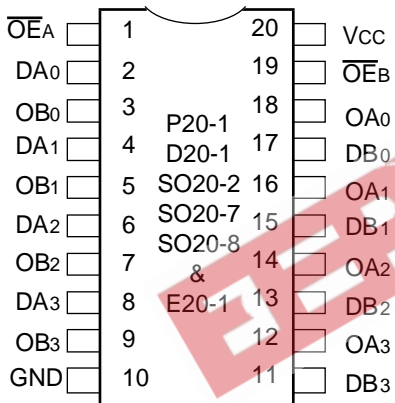

**DIP/SOIC/SSOP/QSOP/CERPACK
 TOP VIEW**

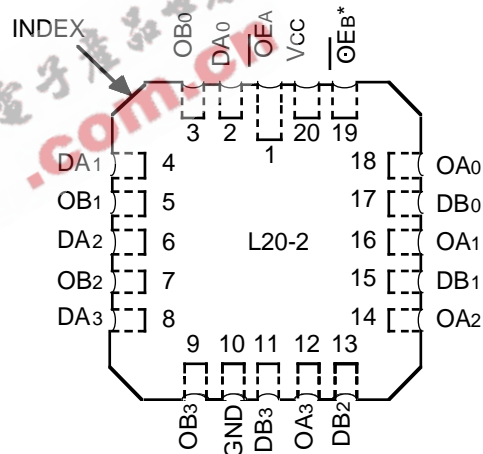

**LCC
 TOP VIEW**

2565 drw 05

2565 drw 08

FCT540/541/2541T

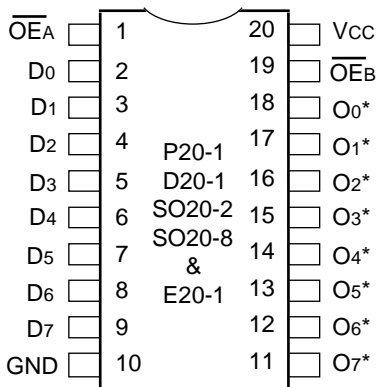

**DIP/SOIC/QSOP/CERPACK
 TOP VIEW**

*Ox for 540, Ox for 541/2541T

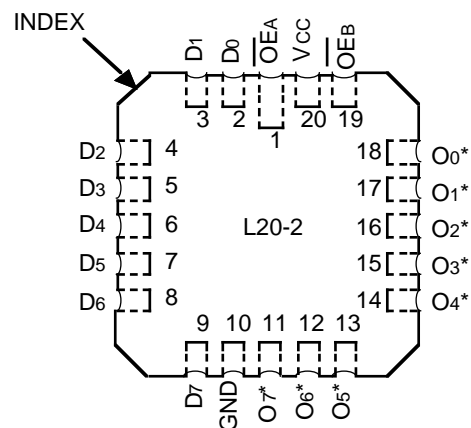

**LCC
 TOP VIEW**

2565 drw 06

2565 drw 09

PIN DESCRIPTION

Pin Names	Description
$\overline{OE}A$, $\overline{OE}B$	3-State Output Enable Inputs (Active LOW)
Dxx	Inputs
Oxx	Outputs

2565 tbl 01

FUNCTION TABLE

Inputs ⁽¹⁾			Outputs ⁽¹⁾			
$\overline{OE}A$	$\overline{OE}B$	D	240	244	540	541
L	L	L	H	L	H	L
L	L	H	L	H	L	H
H	H	X	Z	Z	Z	Z

2565 tbl 02

NOTES:

- H = High Voltage Level
 X = Don't Care
 L = Low Voltage Level
 Z = High Impedance

ABSOLUTE MAXIMUM RATINGS⁽¹⁾

Symbol	Rating	Commercial	Military	Unit
VTERM ⁽²⁾	Terminal Voltage with Respect to GND	-0.5 to +7.0	-0.5 to +7.0	V
VTERM ⁽³⁾	Terminal Voltage with Respect to GND	-0.5 to V _{CC} +0.5	-0.5 to V _{CC} +0.5	V
TA	Operating Temperature	0 to +70	-55 to +125	°C
TBIAS	Temperature Under Bias	-55 to +125	-65 to +135	°C
TSTG	Storage Temperature	-55 to +125	-65 to +150	°C
PT	Power Dissipation	0.5	0.5	W
IOUT	DC Output Current	-60 to +120	-60 to +120	mA

2565 lmk 03

NOTES:

- Stresses greater than those listed under ABSOLUTE MAXIMUM RATINGS may cause permanent damage to the device. This is a stress rating only and functional operation of the device at these or any other conditions above those indicated in the operational sections of this specification is not implied. Exposure to absolute maximum rating conditions for extended periods may affect reliability. No terminal voltage may exceed V_{CC} by +0.5V unless otherwise noted.
- Input and V_{CC} terminals only.
- Outputs and I/O terminals only.

CAPACITANCE (TA = +25°C, f = 1.0MHz)

Symbol	Parameter ⁽¹⁾	Conditions	Typ.	Max.	Unit
CIN	Input Capacitance	V _{IN} = 0V	6	10	pF
COUT	Output Capacitance	V _{OUT} = 0V	8	12	pF

2565 lmk 04

NOTE:

- This parameter is measured at characterization but not tested.

DC ELECTRICAL CHARACTERISTICS OVER OPERATING RANGE

Following Conditions Apply Unless Otherwise Specified:

Commercial: $T_A = 0^\circ\text{C}$ to $+70^\circ\text{C}$, $V_{CC} = 5.0\text{V} \pm 5\%$; Military: $T_A = -55^\circ\text{C}$ to $+125^\circ\text{C}$, $V_{CC} = 5.0\text{V} \pm 10\%$

Symbol	Parameter	Test Conditions ⁽¹⁾	Min.	Typ. ⁽²⁾	Max.	Unit
V_{IH}	Input HIGH Level	Guaranteed Logic HIGH Level	2.0	—	—	V
V_{IL}	Input LOW Level	Guaranteed Logic LOW Level	—	—	0.8	V
I_{IH}	Input HIGH Current ⁽⁴⁾	$V_{CC} = \text{Max.}$ $V_I = 2.7\text{V}$	—	—	± 1	μA
I_{IL}	Input LOW Current ⁽⁴⁾		$V_I = 0.5\text{V}$	—	—	± 1
I_{OZH}	High Impedance Output Current (3-State Output pins) ⁽⁴⁾	$V_{CC} = \text{Max.}$ $V_O = 2.7\text{V}$	—	—	± 1	μA
I_{OZL}			$V_O = 0.5\text{V}$	—	—	± 1
I_I	Input HIGH Current ⁽⁴⁾	$V_{CC} = \text{Max.}, V_I = V_{CC} (\text{Max.})$	—	—	± 1	μA
V_{IK}	Clamp Diode Voltage	$V_{CC} = \text{Min.}, I_{IN} = -18\text{mA}$	—	-0.7	-1.2	V
V_H	Input Hysteresis	—	—	200	—	mV
I_{CC}	Quiescent Power Supply Current	$V_{CC} = \text{Max.}, V_{IN} = \text{GND or } V_{CC}$	—	0.01	1	mA

2565 Ink 05

OUTPUT DRIVE CHARACTERISTICS FOR FCT240/244/540/541T

Symbol	Parameter	Test Conditions ⁽¹⁾	Min.	Typ. ⁽²⁾	Max.	Unit	
V_{OH}	Output HIGH Voltage	$V_{CC} = \text{Min.}$ $V_{IN} = V_{IH} \text{ or } V_{IL}$	$I_{OH} = -6\text{mA MIL.}$	2.4	3.3	—	V
			$I_{OH} = -8\text{mA COM'L.}$	—	—	—	—
			$I_{OH} = -12\text{mA MIL.}$ $I_{OH} = -15\text{mA COM'L.}$	2.0	3.0	—	V
V_{OL}	Output LOW Voltage	$V_{CC} = \text{Min.}$ $V_{IN} = V_{IH} \text{ or } V_{IL}$	—	0.3	0.55	V	
I_{OS}	Short Circuit Current	$V_{CC} = \text{Max.}, V_O = \text{GND}^{(3)}$	-60	-120	-225	mA	

2565 Ink 06

OUTPUT DRIVE CHARACTERISTICS FOR FCT2240/2244/2541T

Symbol	Parameter	Test Conditions ⁽¹⁾	Min.	Typ. ⁽²⁾	Max.	Unit	
I_{ODL}	Output LOW Current	$V_{CC} = 5\text{V}, V_{IN} = V_{IH} \text{ or } V_{IL}, V_{OUT} = 1.5\text{V}^{(3)}$	16	48	—	mA	
I_{ODH}	Output HIGH Current	$V_{CC} = 5\text{V}, V_{IN} = V_{IH} \text{ or } V_{IL}, V_{OUT} = 1.5\text{V}^{(3)}$	-16	-48	—	mA	
V_{OH}	Output HIGH Voltage	$V_{CC} = \text{Min.}$ $V_{IN} = V_{IH} \text{ or } V_{IL}$	$I_{OH} = -12\text{mA MIL.}$	2.4	3.3	—	V
			$I_{OH} = -15\text{mA COM'L.}$	—	—	—	—
V_{OL}	Output LOW Voltage	$V_{CC} = \text{Min.}$ $V_{IN} = V_{IH} \text{ or } V_{IL}$	—	0.3	0.50	V	

2565 Ink 07

NOTES:

- For conditions shown as Max. or Min., use appropriate value specified under Electrical Characteristics for the applicable device type.
- Typical values are at $V_{CC} = 5.0\text{V}$, $+25^\circ\text{C}$ ambient.
- Not more than one output should be shorted at one time. Duration of the short circuit test should not exceed one second.
- The test limit for this parameter is $\pm 5\mu\text{A}$ at $T_A = -55^\circ\text{C}$.

POWER SUPPLY CHARACTERISTICS

Symbol	Parameter	Test Conditions ⁽¹⁾			Min.	Typ. ⁽²⁾	Max.	Unit
ΔI_{CC}	Quiescent Power Supply Current TTL Inputs HIGH	$V_{CC} = \text{Max.}$ $V_{IN} = 3.4V^{(3)}$			—	0.5	2.0	mA
I_{CCD}	Dynamic Power Supply Current ⁽⁴⁾	$V_{CC} = \text{Max.}$ Outputs Open $\overline{OE}_A = \overline{OE}_B = \text{GND}$ One Input Toggling 50% Duty Cycle	$V_{IN} = V_{CC}$ $V_{IN} = \text{GND}$	FCTxxxT	—	0.15	0.25	mA/ MHz
				FCT2xxxT	—	0.06	0.12	
I_C	Total Power Supply Current ⁽⁶⁾	$V_{CC} = \text{Max.}$ Outputs Open $f_i = 10\text{MHz}$ 50% Duty Cycle $\overline{OE}_A = \overline{OE}_B = \text{GND}$ One Bit Toggling	$V_{IN} = V_{CC}$ $V_{IN} = \text{GND}$	FCTxxxT	—	1.5	3.5	mA
				FCT2xxxT	—	0.6	2.2	
			$V_{IN} = 3.4$ $V_{IN} = \text{GND}$	FCTxxxT	—	1.8	4.5	
				FCT2xxxT	—	0.9	3.2	
		$V_{CC} = \text{Max.}$ Outputs Open $f_i = 2.5\text{MHz}$ 50% Duty Cycle $\overline{OE}_A = \overline{OE}_B = \text{GND}$ Eight Bits Toggling	$V_{IN} = V_{CC}$ $V_{IN} = \text{GND}$	FCTxxxT	—	3.0	6.0 ⁽⁵⁾	
				FCT2xxxT	—	1.2	3.4 ⁽⁵⁾	
			$V_{IN} = 3.4$ $V_{IN} = \text{GND}$	FCTxxxT	—	5.0	14.0 ⁽⁵⁾	
				FCT2xxxT	—	3.2	11.4 ⁽⁵⁾	

NOTES:

- For conditions shown as Max. or Min., use appropriate value specified under Electrical Characteristics for the applicable device type.
- Typical values are at $V_{CC} = 5.0V$, +25°C ambient.
- Per TTL driven input ($V_{IN} = 3.4V$). All other inputs at V_{CC} or GND.
- This parameter is not directly testable, but is derived for use in Total Power Supply Calculations.
- Values for these conditions are examples of the I_{CC} formula. These limits are guaranteed but not tested.
- $I_C = I_{QUIESCENT} + I_{INPUTS} + I_{DYNAMIC}$
 $I_C = I_{CC} + \Delta I_{CC} \cdot DH_{NT} + I_{CCD} (f_{CP}/2 + f_i N_i)$
 $I_{CC} = \text{Quiescent Current}$
 $\Delta I_{CC} = \text{Power Supply Current for a TTL High Input } (V_{IN} = 3.4V)$
 $DH = \text{Duty Cycle for TTL Inputs High}$
 $N_T = \text{Number of TTL Inputs at } DH$
 $I_{CCD} = \text{Dynamic Current Caused by an Input Transition Pair (HLH or LHL)}$
 $f_{CP} = \text{Clock Frequency for Register Devices (Zero for Non-Register Devices)}$
 $f_i = \text{Input Frequency}$
 $N_i = \text{Number of Inputs at } f_i$
 All currents are in milliamps and all frequencies are in megahertz.

2565 tbl 08

SWITCHING CHARACTERISTICS OVER OPERATING RANGE FOR FCT240/2240T

Symbol	Parameter	Condition ⁽¹⁾	FCT240T FCT2240T				FCT240AT FCT2240AT				Unit
			Com'l.		Mil.		Com'l.		Mil.		
			Min. ⁽²⁾	Max.	Min. ⁽²⁾	Max.	Min. ⁽²⁾	Max.	Min. ⁽²⁾	Max.	
tPLH tPHL	Propagation Delay DN to ON	CL = 50pF RL = 500Ω	1.5	8.0	1.5	9.0	1.5	4.8	1.5	5.1	ns
tPZH tPZL	Output Enable Time		1.5	10.0	1.5	10.5	1.5	6.2	1.5	6.5	ns
tPHZ tPLZ	Output Disable Time		1.5	9.5	1.5	10.0	1.5	5.6	1.5	5.9	ns

2565 tbl 09

Symbol	Parameter	Condition ⁽¹⁾	FCT240CT FCT2240CT				FCT240DT				Unit
			Com'l.		Mil.		Com'l.		Mil.		
			Min. ⁽²⁾	Max.	Min. ⁽²⁾	Max.	Min. ⁽²⁾	Max.	Min. ⁽²⁾	Max.	
tPLH tPHL	Propagation Delay DN to ON	CL = 50pF RL = 500Ω	1.5	4.3	1.5	4.7	1.5	3.6	—	—	ns
tPZH tPZL	Output Enable Time		1.5	5.8	1.5	6.5	1.5	4.8	—	—	ns
tPHZ tPLZ	Output Disable Time		1.5	5.2	1.5	5.7	1.5	4.0	—	—	ns

2565 tbl 10

SWITCHING CHARACTERISTICS OVER OPERATING RANGE FOR FCT244/2244T

Symbol	Parameter	Condition ⁽¹⁾	FCT244T FCT2244T				FCT244AT FCT2244AT				Unit
			Com'l.		Mil.		Com'l.		Mil.		
			Min. ⁽²⁾	Max.	Min. ⁽²⁾	Max.	Min. ⁽²⁾	Max.	Min. ⁽²⁾	Max.	
tPLH tPHL	Propagation Delay DN to ON	CL = 50pF RL = 500Ω	1.5	6.5	1.5	7.0	1.5	4.8	1.5	5.1	ns
tPZH tPZL	Output Enable Time		1.5	8.0	1.5	8.5	1.5	6.2	1.5	6.5	ns
tPHZ tPLZ	Output Disable Time		1.5	7.0	1.5	7.5	1.5	5.6	1.5	5.9	ns

2565 tbl 11

Symbol	Parameter	Condition ⁽¹⁾	FCT244CT FCT2244CT				FCT244DT				Unit
			Com'l.		Mil.		Com'l.		Mil.		
			Min. ⁽²⁾	Max.	Min. ⁽²⁾	Max.	Min. ⁽²⁾	Max.	Min. ⁽²⁾	Max.	
tPLH tPHL	Propagation Delay DN to ON	CL = 50pF RL = 500Ω	1.5	4.1	1.5	4.6	1.5	3.6	—	—	ns
tPZH tPZL	Output Enable Time		1.5	5.8	1.5	6.5	1.5	4.8	—	—	ns
tPHZ tPLZ	Output Disable Time		1.5	5.2	1.5	5.7	1.5	4.0	—	—	ns

2565 tbl 12

NOTES:

1. See test circuit and waveforms.
2. Minimum limits are guaranteed but not tested on Propagation Delays.

SWITCHING CHARACTERISTICS OVER OPERATING RANGE FOR FCT540/541/2541T

Symbol	Parameter	Condition ⁽¹⁾	FCT540T/541T FCT2541T				FCT540AT/541AT FCT2541AT				FCT540CT/541CT FCT2541CT				Unit
			Com'l.		Mil.		Com'l.		Mil.		Com'l.		Mil.		
			Min. ⁽²⁾	Max.	Min. ⁽²⁾	Max.	Min. ⁽²⁾	Max.	Min. ⁽²⁾	Max.	Min. ⁽²⁾	Max.	Min. ⁽²⁾	Max.	
tPLH tPHL	Propagation Delay DN to $\bar{O}N$ FCT540	CL = 50pF RL = 500Ω	1.5	8.5	1.5	9.5	1.5	4.8	1.5	5.1	1.5	4.3	1.5	4.7	ns
tPLH tPHL	Propagation Delay DN to ON FCT541/2541T		1.5	8.0	1.5	9.0	1.5	4.8	1.5	5.1	1.5	4.1	1.5	4.6	ns
tPZH tPZL	Output Enable Time		1.5	10.0	1.5	10.5	1.5	6.2	1.5	6.5	1.5	5.8	1.5	6.5	ns
tPHZ tPLZ	Output Disable Time		1.5	9.5	1.5	10.0	1.5	5.6	1.5	5.9	1.5	5.2	1.5	5.7	ns

NOTES:

1. See test circuit and waveforms.
2. Minimum limits are guaranteed but not tested on Propagation Delays.

2565 tbl 13



TEST CIRCUITS AND WAVEFORMS

TEST CIRCUITS FOR ALL OUTPUTS

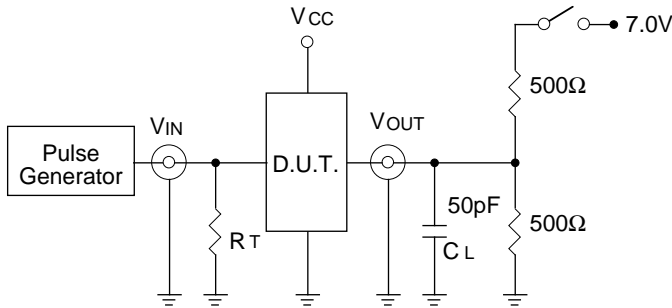

2565 drw 10

SWITCH POSITION

Test	Switch
Open Drain Disable Low Enable Low	Closed
All Other Tests	Open

2565 drw 14

DEFINITIONS:

C_L = Load capacitance: includes jig and probe capacitance.

R_T = Termination resistance: should be equal to Z_{OUT} of the Pulse Generator.

SET-UP, HOLD AND RELEASE TIMES

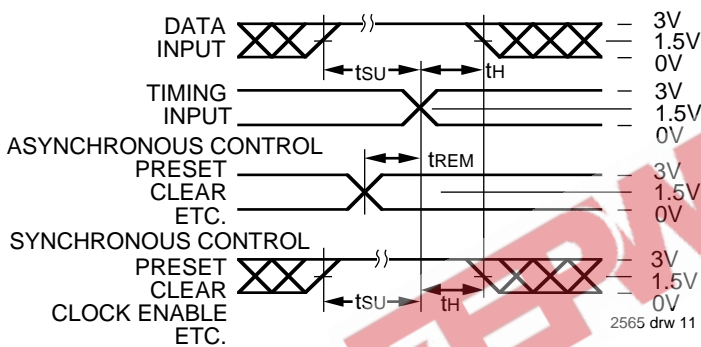

2565 drw 11

PULSE WIDTH

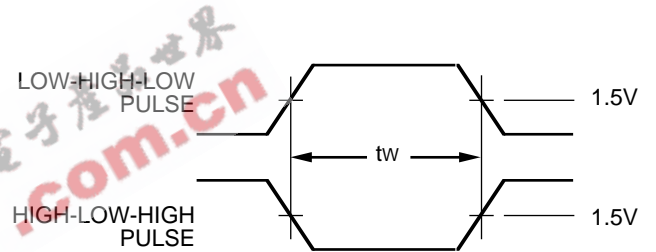

2565 drw 12

PROPAGATION DELAY

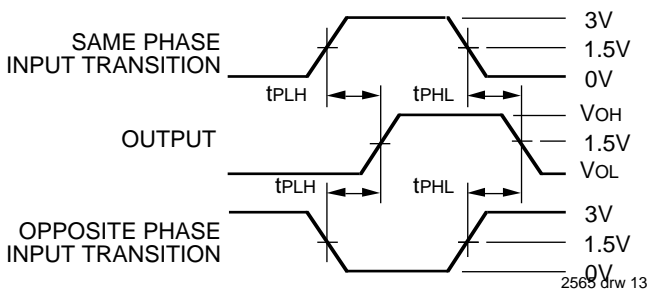

2565 drw 13

ENABLE AND DISABLE TIMES

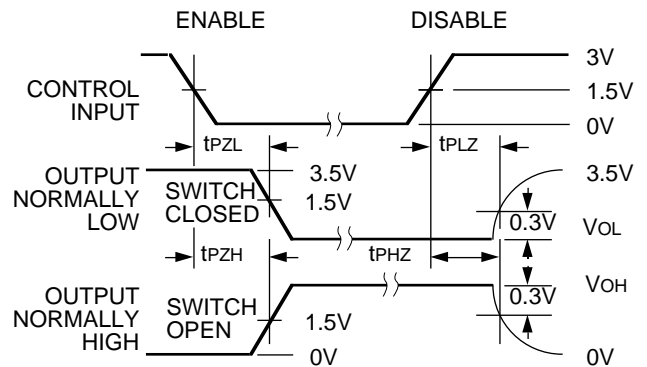

2565 drw 14

NOTES:

1. Diagram shown for input Control Enable-LOW and input Control Disable-HIGH
2. Pulse Generator for All Pulses: Rate $\leq 1.0\text{MHz}$; $t_f \leq 2.5\text{ns}$; $t_r \leq 2.5\text{ns}$

ORDERING INFORMATION

IDT	XX	FCT	X	XXXX	X	X		
Temp. Range	Family	Device Type	Package	Process				
							Blank	Commercial
							B	MIL-STD-883, Class B
							P	Plastic DIP
							D	CERDIP
							SO	Small Outline IC
							L	Leadless Chip Carrier
							E	CERPACK
							PY	Shrink Small Outline Package
							Q	Quarter-size Small Outline Package
							240T	Inverting Octal Buffer/Line Driver
							244T	Non-Inverting Octal Buffer/Line Driver
							540T	Non-Inverting Octal Buffer/Line Driver
							541T	Inverting Octal Buffer/Line Driver
							240AT	Non-Inverting Octal Buffer/Line Driver
							244AT	
							540AT	
							541AT	
							240CT	
							244CT	
							540CT	
							541CT	
							240DT	
							244DT	
							Blank	High Drive
							2	Balanced Drive
							54	-55°C to +125°C
							74	0°C to +70°C

