

HD74LS164 • 8-Bit Parallel-Out Serial-In Shift Registers

This 8-bit shift register features gated serial inputs and an asynchronous clear. The gated serial inputs (A and B) permit complete control over incoming data as a low at either (or both) input(s) inhibits entry of the new data and resets the first flip-flop to the low level at the next clock pulse. A high-level input enables the other input which will then determine the state of the first flip-flop. Data at the serial inputs may be changed while the clock is high or low, but only information meeting the setup requirements will be entered. Clocking occurs on the low-to-high-level transition of the clock input.

■ PIN ARRANGEMENT

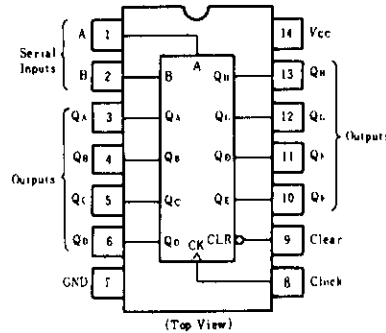

■ BLOCK DIAGRAM

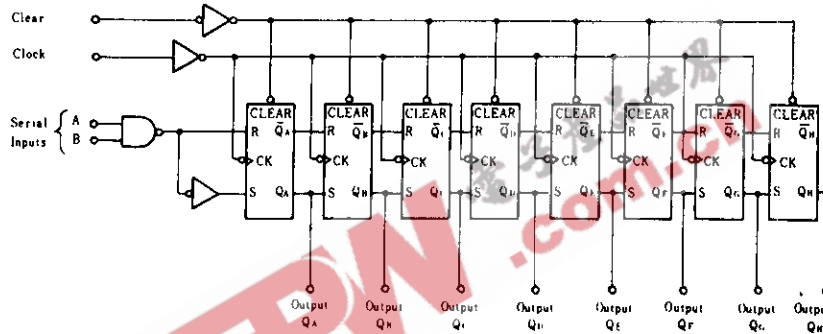

■ FUNCTION TABLE

Inputs				Outputs			
Clear	Clock	A	B	QA	QB	...	QH
L	X	X	X	L	L	L	L
H	L	X	X	QA0	QB0		QH0
H	↑	H	H	H	QA _n		QH _n
H	↑	L	X	L	QA _n		QH _n
H	↑	X	L	L	QA _n		QH _n

■ RECOMMENDED OPERATING CONDITIONS

Item	Symbol	min	typ	max	Unit
Clock frequency	f_{clock}	0	—	25	MHz
Clock pulse width	$t_{w(CK)}$	20	—	—	ns
Clear pulse width	$t_{w(CLR)}$	20	—	—	ns
Data setup time	t_{su}	15	—	—	ns
Data hold time	t_h	5	—	—	ns

- Notes) 1. H; high level, L; low level, X; irrelevant
 2. ↑; transition from low to high level
 3. QA0, QB0, QH0; the level of QA, QB, or QH, respectively, before the indicated steady-state input conditions were established.
 4. QAn, QGn; the level of QA or QG before the most-recent ↑ transition of the clock; indicates a one-bit shift.

■ TYPICAL CLEAR, SHIFT, AND CLEAR SEQUENCES

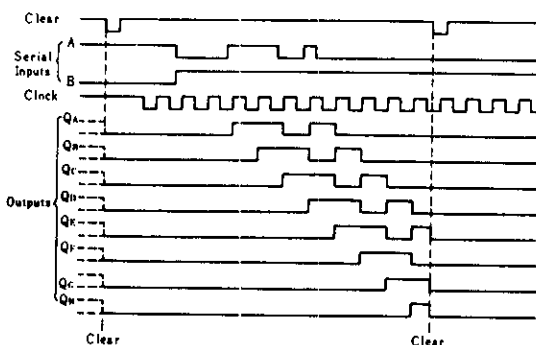

HD74LS164

ELECTRICAL CHARACTERISTICS ($T_a = -20 \sim +75^\circ\text{C}$)

Item	Symbol	Test Conditions	min	typ*	max	Unit
Input voltage	V_{IH}		2.0			V
	V_{IL}				0.8	V
Output voltage	V_{OH}	$V_{CC} = 4.75\text{V}, V_{IH} = 2\text{V}, V_{IL} = 0.8\text{V}, I_{OH} = -400\mu\text{A}$	2.7			V
	V_{OL}	$V_{CC} = 4.75\text{V}, V_{IH} = 2\text{V}, V_{IL} = 0.8\text{V}$ $I_{OL} = 4\text{mA}$ $I_{OL} = 8\text{mA}$			0.4 0.5	V
Input current	I_{IH}	$V_{CC} = 5.25\text{V}, V_I = 2.7\text{V}$			20	μA
	I_{IL}	$V_{CC} = 5.25\text{V}, V_I = 0.4\text{V}$			0.4	mA
	I_i	$V_{CC} = 5.25\text{V}, V_I = 7\text{V}$			0.1	mA
Short-circuit output current	I_{OS}	$V_{CC} = 5.25\text{V}$	-20		100	mA
Supply current**	I_{CC}	$V_{CC} = 5.25\text{V}$		16	27	mA
Input clamp voltage	V_{IA}	$V_{CC} = 4.75\text{V}, I_{IH} = -18\text{mA}$			-1.5	V

* $V_{CC} = 5\text{V}, T_a = 25^\circ\text{C}$

** I_{CC} is measured with outputs open, serial inputs grounded, the clock input at 2.4V, and a momentary grounded, then 4.5V applied to clear.

SWITCHING CHARACTERISTICS ($V_{CC} = 5\text{V}, T_a = 25^\circ\text{C}$)

Item	Symbol	Inputs	Outputs	Test Conditions	min	typ	max	Unit
Maximum clock frequency	f_{max}				25	36		MHz
Propagation delay time	t_{PHL}	Clear	Q	$C_L = 15\text{pF}, R_L = 2\text{k}\Omega$		24	36	ns
	t_{PLH}	Clock	Q			17	27	ns
	t_{PHL}	Clock	Q			21	32	ns

TESTING METHOD

1) Test Circuit

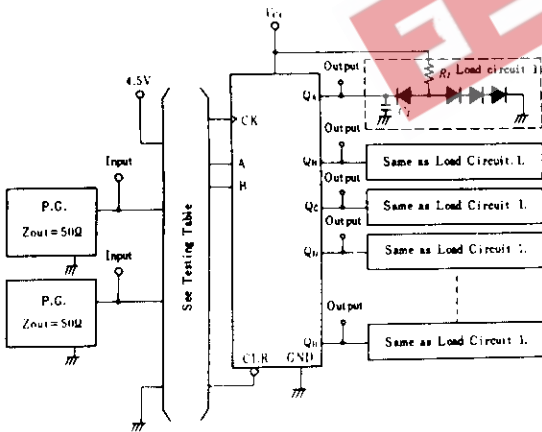

Waveform

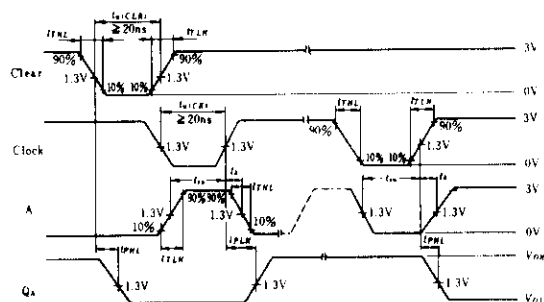

Notes) Q_A output is illustrated. Relationship of serial input A and B data to other Q outputs is illustrated in the timing chart.

- Notes) 1. Input pulse: $t_{TLH} \leq 15\text{ns}, t_{THL} \leq 6\text{ns}, PRR = 1\text{MHz}$,
(Clock, Clear), $PRR = 500\text{kHz}$ (A or B)
2. C_L includes probe and jig capacitance.
3. All diodes are 1S2074 $\text{\textcircled{E}}$

2) Testing Table

Item	From input to output	Inputs				Outputs							
		CLR	CK	A	B	Q_A	Q_B	Q_C	Q_D	Q_E	Q_F	Q_G	Q_H
f_{max}		4.5V	IN	IN	4.5V	OUT	OUT	OUT	OUT	OUT	OUT	OUT	OUT
t_{PLH}	Clear \rightarrow Q	IN	IN	IN	4.5V	OUT	OUT	OUT	OUT	OUT	OUT	OUT	OUT
t_{PHL}	CK \rightarrow Q	4.5V	IN	IN	4.5V	OUT	OUT	OUT	OUT	OUT	OUT	OUT	OUT

Unit: mm

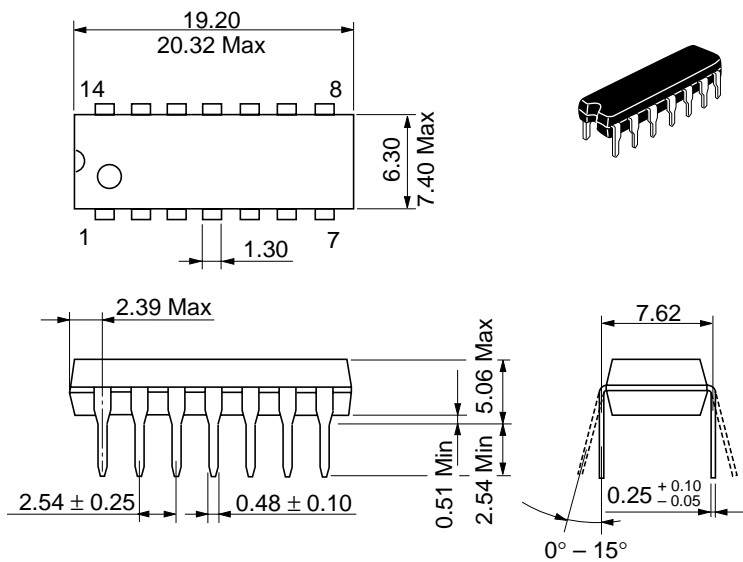

Hitachi Code	DP-14
JEDEC	Conforms
EIAJ	Conforms
Weight (reference value)	0.97 g

Unit: mm

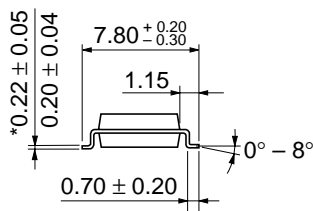
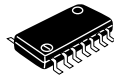
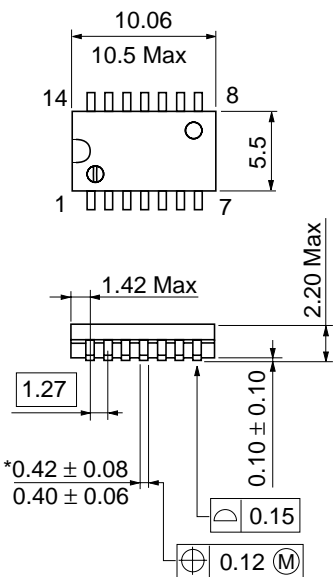

*Dimension including the plating thickness
Base material dimension

Hitachi Code	FP-14DA
JEDEC	—
EIAJ	Conforms
Weight (reference value)	0.23 g

EEPW 电子产品世界 .com.cn

Unit: mm

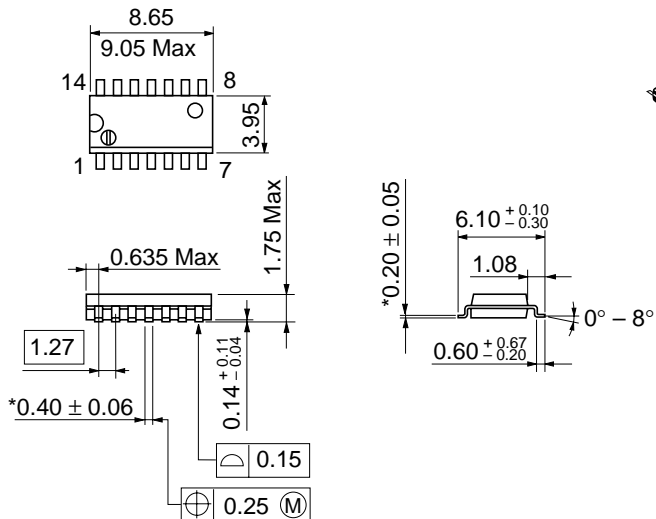

Hitachi Code	FP-14DN
JEDEC	Conforms
EIAJ	Conforms
Weight (reference value)	0.13 g

*Pd plating

Cautions

1. Hitachi neither warrants nor grants licenses of any rights of Hitachi's or any third party's patent, copyright, trademark, or other intellectual property rights for information contained in this document. Hitachi bears no responsibility for problems that may arise with third party's rights, including intellectual property rights, in connection with use of the information contained in this document.
2. Products and product specifications may be subject to change without notice. Confirm that you have received the latest product standards or specifications before final design, purchase or use.
3. Hitachi makes every attempt to ensure that its products are of high quality and reliability. However, contact Hitachi's sales office before using the product in an application that demands especially high quality and reliability or where its failure or malfunction may directly threaten human life or cause risk of bodily injury, such as aerospace, aeronautics, nuclear power, combustion control, transportation, traffic, safety equipment or medical equipment for life support.
4. Design your application so that the product is used within the ranges guaranteed by Hitachi particularly for maximum rating, operating supply voltage range, heat radiation characteristics, installation conditions and other characteristics. Hitachi bears no responsibility for failure or damage when used beyond the guaranteed ranges. Even within the guaranteed ranges, consider normally foreseeable failure rates or failure modes in semiconductor devices and employ systemic measures such as fail-safes, so that the equipment incorporating Hitachi product does not cause bodily injury, fire or other consequential damage due to operation of the Hitachi product.
5. This product is not designed to be radiation resistant.
6. No one is permitted to reproduce or duplicate, in any form, the whole or part of this document without written approval from Hitachi.
7. Contact Hitachi's sales office for any questions regarding this document or Hitachi semiconductor products.

HITACHI

Hitachi, Ltd.

Semiconductor & Integrated Circuits.
Nippon Bldg., 2-6-2, Ohte-machi, Chiyoda-ku, Tokyo 100-0004, Japan
Tel: Tokyo (03) 3270-2111 Fax: (03) 3270-5109

URL North America : <http://semiconductor.hitachi.com/>
 Europe : <http://www.hitachi-eu.com/hel/ecg>
 Asia (Singapore) : <http://www.has.hitachi.com.sg/grp3/sicd/index.htm>
 Asia (Taiwan) : http://www.hitachi.com.tw/E/Product/SICD_Frame.htm
 Asia (HongKong) : <http://www.hitachi.com.hk/eng/bo/grp3/index.htm>
 Japan : <http://www.hitachi.co.jp/Sicd/indx.htm>

For further information write to:

Hitachi Semiconductor
(America) Inc.
179 East Tasman Drive,
San Jose, CA 95134
Tel: <1> (408) 433-1990
Fax: <1> (408) 433-0223

Hitachi Europe GmbH
Electronic components Group
Dornacher StraÙe 3
D-85622 Feldkirchen, Munich
Germany
Tel: <49> (89) 9 9180-0
Fax: <49> (89) 9 29 30 00

Hitachi Europe Ltd.
Electronic Components Group.
Whitebrook Park
Lower Cookham Road
Maidenhead
Berkshire SL6 8YA, United Kingdom
Tel: <44> (1628) 585000
Fax: <44> (1628) 778322

Hitachi Asia Pte. Ltd.
16 Collyer Quay #20-00
Hitachi Tower
Singapore 049318
Tel: 535-2100
Fax: 535-1533

Hitachi Asia Ltd.
Taipei Branch Office
3F, Hung Kuo Building, No.167,
Tun-Hwa North Road, Taipei (105)
Tel: <886> (2) 2718-3666
Fax: <886> (2) 2718-8180

Hitachi Asia (Hong Kong) Ltd.
Group III (Electronic Components)
7/F., North Tower, World Finance Centre,
Harbour City, Canton Road, Tsim Sha Tsui,
Kowloon, Hong Kong
Tel: <852> (2) 735 9218
Fax: <852> (2) 730 0281
Telex: 40815 HITEC HX

Copyright ' Hitachi, Ltd., 1999. All rights reserved. Printed in Japan.

HITACHI