

74VCXH2245

Low Voltage Bidirectional Transceiver with Bushold and 26Ω Series Resistors in B Outputs

General Description

The VCXH2245 contains eight non-inverting bidirectional buffers with 3-STATE outputs and is intended for bus oriented applications. The T/R input determines the direction of data flow. The \overline{OE} input disables both the A and B Ports by placing them in a high impedance state. The VCXH2245 data inputs include active bushold circuitry, eliminating the need for external pull-up resistors to hold unused or floating data inputs at a valid logic level.

The 74VCXH2245 is designed for low voltage (1.65V to 3.6V) V_{CC} applications. The VCXH2245 is also designed with 26Ω series resistance in the B Port outputs. This design reduces line noise in applications such as memory address drivers, clock drivers, and bus transceivers transmitters

The 74VCXH2245 is fabricated with an advanced CMOS technology to achieve high-speed operation while maintaining low CMOS power dissipation.

Features

- 1.65V-3.6V V_{CC} supply operation
- 3.6V tolerant control inputs
- Bushold on data inputs eliminates the need for external pull-up/pull-down resistors
- 26Ω series resistors in B Port outputs
- t_{PD} (A to B)
 - 4.4 ns max for 3.0V to 3.6V V_{CC}
 - 5.6 ns max for 2.3V to 2.7V V_{CC}
 - 9.8 ns max for 1.65V to 1.95V V_{CC}
- Static Drive (I_{OH}/I_{OL} B outputs):
 - ±12 mA @ 3.0V V_{CC}
 - ±8 mA @ 2.3V V_{CC}
 - ±3 mA @ 1.65V V_{CC}
- Uses patented Quiet Series™ noise/EMI reduction circuitry
- Latchup performance exceeds 300 mA
- ESD performance:
 - Human body model > 2000V
 - Machine model > 200V

Ordering Code:

Order Number	Package Number	Package Description
74VCXH2245WM	M20B	20-Lead Small Outline Integrated Circuit (SOIC), JEDEC MS-013, 0.300" Wide
74VCXH2245MTC	MTC20	20-Lead Thin Shrink Small Outline Package (TSSOP), JEDEC MO-153, 4.4mm Wide

Devices also available in Tape and Reel. Specify by appending the suffix letter "X" to the ordering code.

Logic Symbol

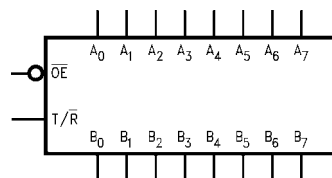

Connection Diagram

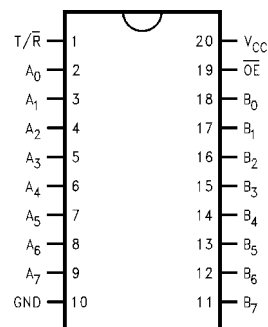

Quiet Series™ is a trademark of Fairchild Semiconductor Corporation.

Pin Descriptions

Pin Names	Description
\overline{OE}	Output Enable Input (Active LOW)
T/\overline{R}	Transmit/Receive Input
A_0-A_7	Side A Bushold Inputs or 3-STATE Outputs
B_0-B_7	Side B Bushold Inputs or 3-STATE Outputs

Truth Table

Inputs		Outputs
\overline{OE}	T/\overline{R}	
L	L	Bus B_0-B_7 Data to Bus A_0-A_7
L	H	Bus A_0-A_7 Data to Bus B_0-B_7
H	X	HIGH Z State on A_0-A_7, B_0-B_7

H = HIGH Voltage Level
 L = LOW Voltage Level
 X = Immaterial
 Z = High Impedance

Logic Diagram

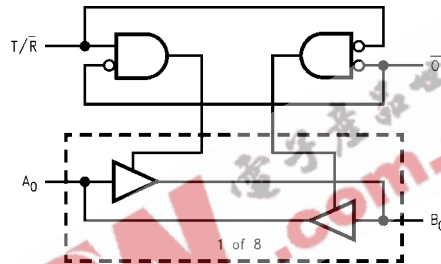

Absolute Maximum Ratings (Note 1)

Supply Voltage (V_{CC})	-0.5V to +4.6V
DC Input Voltage (V_I)	
$\overline{T/R}, \overline{OE}$	-0.5V to 4.6 V
I/O Ports	-0.5V to $V_{CC} + 0.5V$
DC Output Voltage (V_O) (Note 2)	-0.5V to $V_{CC} + 0.5V$
DC Input Diode Current (I_{IK}) $V_I < 0V$	-50 mA
DC Output Diode Current (I_{OK})	
$V_O < 0V$	-50 mA
$V_O > V_{CC}$	+50 mA
DC Output Source/Sink Current (I_{OH}/I_{OL})	± 50 mA
DC V_{CC} or Ground Current	± 100 mA
Storage Temperature (T_{STG})	-65°C to +150°C

Recommended Operating Conditions (Note 3)

Power Supply Voltage (V_{CC})	
Operating	1.65V to 3.6V
Data Retention Only	1.2V to 3.6V
Input Voltage	-0.3V to V_{CC}
Output Voltage (V_O)	0V to V_{CC}
Output Current in I_{OH}/I_{OL} - A Outputs	
$V_{CC} = 3.0V$ to 3.6V	± 24 mA
$V_{CC} = 2.3V$ to 2.7V	± 18 mA
$V_{CC} = 1.65V$ to 2.3V	± 6 mA
Output Current in I_{OH}/I_{OL} - B Outputs	
$V_{CC} = 3.0V$ to 3.6V	± 12 mA
$V_{CC} = 2.3V$ to 2.7V	± 8 mA
$V_{CC} = 1.65V$ to 2.3V	± 3 mA
Free Air Operating Temperature (T_A)	-40°C to +85°C
Minimum Input Edge Rate ($\Delta t/\Delta V$)	
$V_{IN} = 0.8V$ to 2.0V, $V_{CC} = 3.0V$	10 ns/V

Note 1: The Absolute Maximum Ratings are those values beyond which the safety of the device cannot be guaranteed. The device should not be operated at these limits. The parametric values defined in the Electrical Characteristics tables are not guaranteed at the Absolute Maximum Ratings. The "Recommended Operating Conditions" table will define the conditions for actual device operation.

Note 2: I_O Absolute Maximum Rating must be observed.

Note 3: Floating or unused control inputs must be held HIGH or LOW.

DC Electrical Characteristics ($2.7V < V_{CC} \leq 3.6V$)

Symbol	Parameter	Conditions	V_{CC} (V)	Min	Max	Units
V_{IH}	HIGH Level Input Voltage		2.7-3.6	2.0		V
V_{IL}	LOW Level Input Voltage		2.7-3.6		0.8	V
V_{OH}	HIGH Level Output Voltage A Outputs	$I_{OH} = -100 \mu A$	2.7-3.6	$V_{CC} - 0.2$		V
		$I_{OH} = -12 \text{ mA}$	2.7	2.2		
		$I_{OH} = -18 \text{ mA}$	3.0	2.4		
		$I_{OH} = -24 \text{ mA}$	3.0	2.2		
V_{OH}	HIGH Level Output Voltage B Outputs	$I_{OH} = -100 \mu A$	2.7-3.6	$V_{CC} - 0.2$		V
		$I_{OH} = -6 \text{ mA}$	2.7	2.2		
		$I_{OH} = -8 \text{ mA}$	3.0	2.4		
		$I_{OH} = -12 \text{ mA}$	3.0	2.2		
V_{OL}	LOW Level Output Voltage A Outputs	$I_{OL} = 100 \mu A$	2.7-3.6		0.2	V
		$I_{OL} = 12 \text{ mA}$	2.7	0.4		
		$I_{OL} = 18 \text{ mA}$	3.0	0.4		
		$I_{OL} = 24 \text{ mA}$	3.0	0.55		
V_{OL}	LOW Level Output Voltage B Outputs	$I_{OL} = 100 \mu A$	2.7-3.6		0.2	V
		$I_{OL} = 6 \text{ mA}$	2.7	0.4		
		$I_{OL} = 8 \text{ mA}$	3.0	0.55		
		$I_{OL} = 12 \text{ mA}$	3.0	0.8		
I_I	Input Leakage Current	$V_{IN} = V_{CC}$ or GND	2.7-3.6		± 5.0	μA
$I_{I(HOLD)}$	Bushold Input Minimum	$V_{IN} = 0.8V$	3.0	75		μA
	Drive Hold Current	$V_{IN} = 2.0V$	3.0	-75		μA
$I_{I(OD)}$	Bushold Input Over-Drive Current to Change State	(Note 4)	3.6	450		μA
		(Note 5)	3.6	-450		μA
I_{OZ}	3-STATE Output Leakage	$V_O = V_{CC}$ or GND $V_I = V_{IH}$ or V_{IL}	2.7-3.6		± 10	μA
I_{CC}	Quiescent Supply Current	$V_I = V_{CC}$ or GND	2.7-3.6		20	μA
ΔI_{CC}	Increase in I_{CC} per Input	$V_{IH} = V_{CC} - 0.6V$	2.7-3.6		750	μA

Note 4: An external driver must source at least the specified current to switch from LOW-to-HIGH.

Note 5: An external driver must sink at least the specified current to switch from HIGH-to-LOW.

DC Electrical Characteristics (2.3V ≤ V _{CC} ≤ 2.7V)						
Symbol	Parameter	Conditions	V _{CC} (V)	Min	Max	Units
V _{IH}	HIGH Level Input Voltage		2.3–2.7	1.6		V
V _{IL}	LOW Level Input Voltage		2.3–2.7		0.7	V
V _{OH}	HIGH Level Output Voltage A Outputs	I _{OH} = –100 μA	2.3–2.7	V _{CC} – 0.2		V
		I _{OH} = –6 mA	2.3	2.0		
		I _{OH} = –12 mA	2.3	1.8		
		I _{OH} = –18 mA	2.3	1.7		
V _{OH}	HIGH Level Output Voltage B Outputs	I _{OH} = –100 μA	2.3–2.7	V _{CC} – 2		V
		I _{OH} = –4 mA	2.3	2.0		
		I _{OH} = –6 mA	2.3	1.8		
		I _{OH} = –8 mA	2.3	1.7		
V _{OL}	LOW Level Output Voltage A Outputs	I _{OL} = 100 μA	2.3–2.7		0.2	V
		I _{OL} = 12 mA	2.3		0.4	
		I _{OL} = 18 mA	2.3		0.6	
V _{OL}	LOW Level Output Voltage B Outputs	I _{OL} = 100 μA	2.3–2.7		0.2	V
		I _{OL} = 6 mA	2.3		0.4	
		I _{OL} = 8 mA	2.3		0.6	
I _I	Input Leakage Current	V _{IN} = V _{CC} or GND	2.3–2.7		±5.0	μA
I _{I(HOLD)}	Bushold Input Minimum Drive Hold Current	V _{IN} = 0.7V	2.3	45		μA
		V _{IN} = 1.6V	2.3	–45		
I _{I(OD)}	Bushold Input Over-Drive Current to Change State	(Note 6)	2.7	300		μA
		(Note 7)	2.7	–300		
I _{OZ}	3-STATE Output Leakage	V _O = V _{CC} or GND V _I = V _{IH} or V _{IL}	2.3–2.7		±10	μA
I _{CC}	Quiescent Supply Current	V _I = V _{CC} or GND	2.3–2.7		20	μA
<p>Note 6: An external driver must source at least the specified current to switch from LOW-to-HIGH.</p> <p>Note 7: An external driver must sink at least the specified current to switch from HIGH-to-LOW.</p>						
DC Electrical Characteristics (1.65V ≤ V _{CC} < 2.3V)						
Symbol	Parameter	Conditions	V _{CC} (V)	Min	Max	Units
V _{IH}	HIGH Level Input Voltage		1.65–2.3	0.65 x V _{CC}		V
V _{IL}	LOW Level Input Voltage		1.65–2.3		0.35 x V _{CC}	V
V _{OH}	HIGH Level Output Voltage A Outputs	I _{OH} = –100 μA	1.65–1.95	V _{CC} – 0.2		V
		I _{OH} = –6 mA	1.65	1.25		
V _{OH}	HIGH Level Output Voltage B Outputs	I _{OH} = –100 μA	1.65–2.3	V _{CC} – 0.2		V
		I _{OH} = –3 mA	1.65	1.25		
V _{OL}	LOW Level Output Voltage A Outputs	I _{OL} = 100 μA	1.65–2.3		0.2	V
		I _{OL} = 6 mA	1.65		0.3	
V _{OL}	LOW Level Output Voltage B Outputs	I _{OL} = 100 μA	1.65–2.3		0.2	V
		I _{OL} = 3 mA	1.65		0.3	
I _I	Input Leakage Current	0 ≤ V _I ≤ 3.6V	1.65–2.3		±5.0	μA
I _{I(HOLD)}	Bushold Input Minimum Drive Hold Current	V _{IN} = 0.57V	1.65	25		μA
		V _{IN} = 1.07V	1.65	–25		
I _{I(OD)}	Bushold Input Over-Drive Current to Change State	(Note 8)	1.95	200		μA
		(Note 9)	1.95	–200		
I _{OZ}	3-STATE Output Leakage	V _O = V _{CC} or GND	1.65–2.3		±10	μA
I _{CC}	Quiescent Supply Current	V _I = V _{CC} or GND	1.65–2.3		20	μA
<p>Note 8: An external driver must source at least the specified current to switch from LOW-to-HIGH.</p> <p>Note 9: An external driver must sink at least the specified current to switch from HIGH-to-LOW.</p>						

AC Electrical Characteristics (Note 10)								
Symbol	Parameter	$T_A = -40^\circ\text{C to } +85^\circ\text{C}, C_L = 30\text{ pF}, R_L = 500\Omega$						Units
		$V_{CC} = 3.3V \pm 0.3V$		$V_{CC} = 2.5V \pm 0.2V$		$V_{CC} = 1.8V \pm 0.15V$		
		Min	Max	Min	Max	Min	Max	
t_{PHL} t_{PLH}	Propagation Delay, A to B	0.6	4.4	0.8	5.6	1.5	9.8	ns
t_{PHL} t_{PLH}	Propagation Delay, B to A	0.6	3.5	0.8	4.2	1.5	8.4	ns
t_{PZL} t_{PZH}	Output Enable Time, A to B	0.6	5.0	0.8	6.6	1.5	9.8	ns
t_{PZL} t_{PZH}	Output Enable Time, B to A	0.6	4.5	0.8	5.6	1.5	9.8	ns
t_{PLZ} t_{PHZ}	Output Disable Time, A to B	0.6	4.2	0.8	4.7	1.5	8.5	ns
t_{PLZ} t_{PHZ}	Output Disable Time, B to A	0.6	3.6	0.8	4.0	1.5	7.2	ns
t_{OSHL} t_{OSLH}	Output to Output Skew (Note 11)		0.5		0.5		0.75	ns

Note 10: For $C_L = 50\text{ pF}$, add approximately 300 ps to the AC maximum specification.

Note 11: Skew is defined as the absolute value of the difference between the actual propagation delay for any two separate outputs of the same device. The specification applies to any outputs switching in the same direction, either HIGH-to-LOW (t_{OSHL}) or LOW-to-HIGH (t_{OSLH}).

Dynamic Switching Characteristics

Symbol	Parameter	Conditions	V_{CC} (V)	$T_A = 25^\circ\text{C}$	Units
				Typical	
V_{OLP}	Quiet Output Dynamic Peak V_{OL} , B to A	$C_L = 30\text{ pF}, V_{IH} = V_{CC}, V_{IL} = 0V$	1.8	0.3	V
			2.5	0.7	
			3.3	1.0	
V_{OLP}	Quiet Output Dynamic Peak V_{OL} , A to B	$C_L = 30\text{ pF}, V_{IH} = V_{CC}, V_{IL} = 0V$	1.8	0.2	V
			2.5	0.45	
			3.3	0.65	
V_{OLV}	Quiet Output Dynamic Valley V_{OL} , B to A	$C_L = 30\text{ pF}, V_{IH} = V_{CC}, V_{IL} = 0V$	1.8	-0.3	V
			2.5	-0.7	
			3.3	-1.0	
V_{OLV}	Quiet Output Dynamic Valley V_{OL} , A to B	$C_L = 30\text{ pF}, V_{IH} = V_{CC}, V_{IL} = 0V$	1.8	-0.2	V
			2.5	-0.45	
			3.3	-0.65	
V_{OHV}	Quiet Output Dynamic Valley V_{OH} , B to A	$C_L = 30\text{ pF}, V_{IH} = V_{CC}, V_{IL} = 0V$	1.8	1.3	V
			2.5	1.7	
			3.3	2.0	
V_{OHV}	Quiet Output Dynamic Valley V_{OH} , A to B	$C_L = 30\text{ pF}, V_{IH} = V_{CC}, V_{IL} = 0V$	1.8	1.5	V
			2.5	2.0	
			3.3	2.5	

Capacitance

Symbol	Parameter	Conditions	$T_A = +25^\circ\text{C}$	Units
			Typical	
C_{IN}	Input Capacitance	$V_I = 0V$ or V_{CC} , $V_{CC} = 1.8V, 2.5V$ or $3.3V$	6	pF
$C_{I/O}$	Input/Output Capacitance	$V_I = 0V$ or V_{CC} , $V_{CC} = 1.8V, 2.5V$ or $3.3V$	7	pF
C_{PD}	Power Dissipation Capacitance	$V_I = 0V$ or V_{CC} , $f = 10\text{ MHz}$, $V_{CC} = 1.8V, 2.5V$ or $3.3V$	20	pF

AC Loading and Waveforms

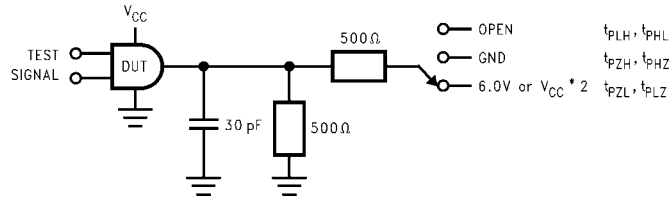

FIGURE 1. AC Test Circuit

TEST	SWITCH
t_{PLH}, t_{PHL}	Open
t_{PZL}, t_{PLZ}	6V at $V_{CC} = 3.3 \pm 0.3V$; $V_{CC} \times 2$ at $V_{CC} = 2.5V \pm 0.2V; 1.8V \pm 0.15V$
t_{PZH}, t_{PHZ}	GND

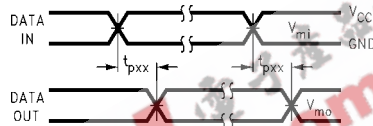

FIGURE 2. Waveform for Inverting and Non-inverting Functions

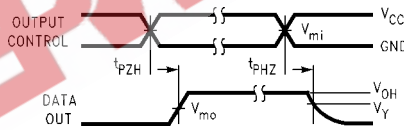

FIGURE 3. 3-STATE Output High Enable and Disable Times for Low Voltage Logic

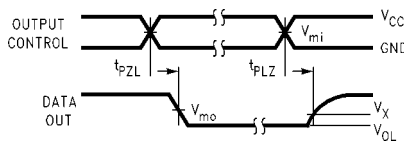
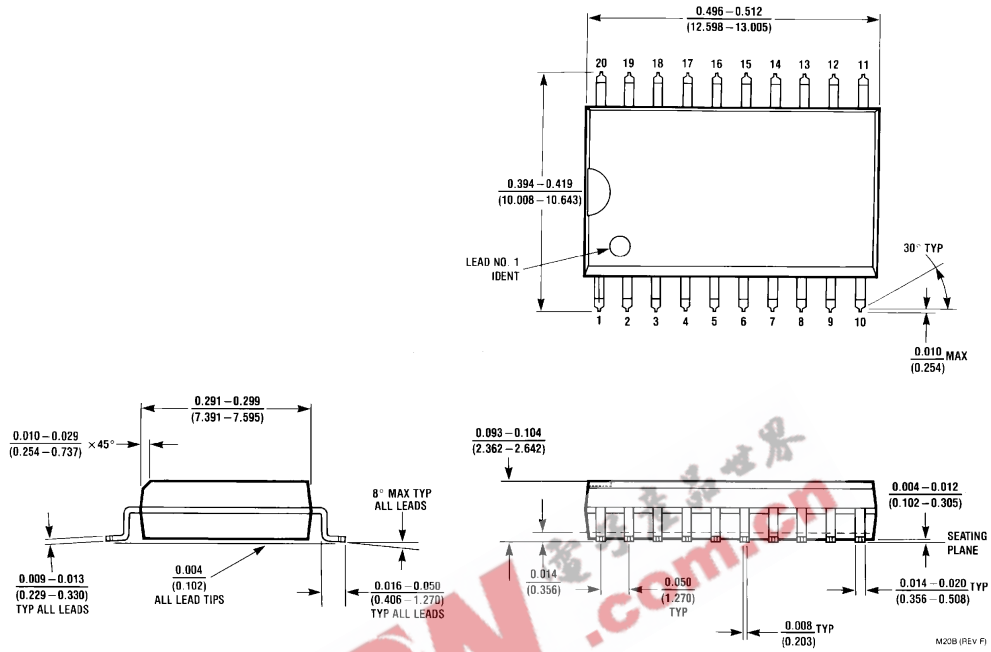

FIGURE 4. 3-STATE Output Low Enable and Disable Times for Low Voltage Logic

Symbol	V_{CC}		
	$3.3V \pm 0.3V$	$2.5V \pm 0.2V$	$1.8V \pm 0.15V$
V_{mi}	1.5V	$V_{CC}/2$	$V_{CC}/2$
V_{mo}	1.5V	$V_{CC}/2$	$V_{CC}/2$
V_x	$V_{OL} + 0.3V$	$V_{OL} + 0.15V$	$V_{OL} + 0.15V$
V_y	$V_{OH} - 0.3V$	$V_{OH} - 0.15V$	$V_{OH} - 0.15V$

Physical Dimensions inches (millimeters) unless otherwise noted



**20-Lead Small Outline Integrated Circuit (SOIC), JEDEC MS-013, 0.300" Wide
Package Number M20B**

Physical Dimensions inches (millimeters) unless otherwise noted (Continued)

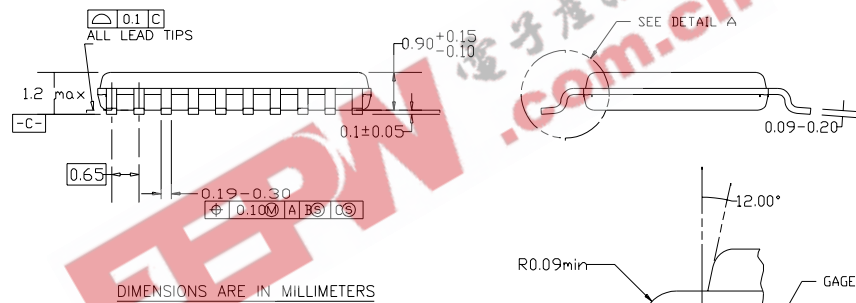
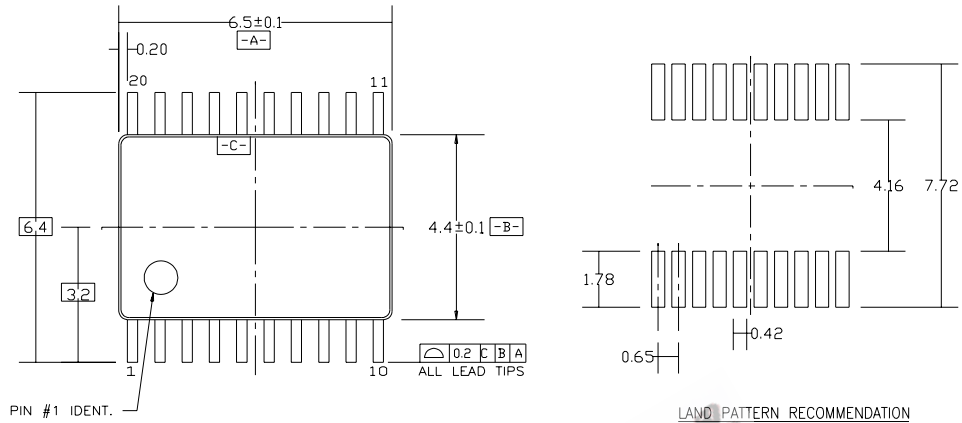

NOTES:

- A. CONFORMS TO JEDEC REGISTRATION MO-153, VARIATION AC, REF NOTE 6, DATE 7/93.
- B. DIMENSIONS ARE IN MILLIMETERS.
- C. DIMENSIONS ARE EXCLUSIVE OF BURRS, MOLDS FLASH, AND TIE BAR EXTRUSIONS.
- D. DIMENSIONS AND TOLERANCES PER ANSI Y14.5M, 1982.

**20-Lead Thin Shrink Small Outline Package (TSSOP), JEDEC MO-153, 4.4mm Wide
Package Number MTC20**

Fairchild does not assume any responsibility for use of any circuitry described, no circuit patent licenses are implied and Fairchild reserves the right at any time without notice to change said circuitry and specifications.

LIFE SUPPORT POLICY

FAIRCHILD'S PRODUCTS ARE NOT AUTHORIZED FOR USE AS CRITICAL COMPONENTS IN LIFE SUPPORT DEVICES OR SYSTEMS WITHOUT THE EXPRESS WRITTEN APPROVAL OF THE PRESIDENT OF FAIRCHILD SEMICONDUCTOR CORPORATION. As used herein:

1. Life support devices or systems are devices or systems which, (a) are intended for surgical implant into the body, or (b) support or sustain life, and (c) whose failure to perform when properly used in accordance with instructions for use provided in the labeling, can be reasonably expected to result in a significant injury to the user.
2. A critical component in any component of a life support device or system whose failure to perform can be reasonably expected to cause the failure of the life support device or system, or to affect its safety or effectiveness.

www.fairchildsemi.com