

**STYLE 2
STRAIGHT**

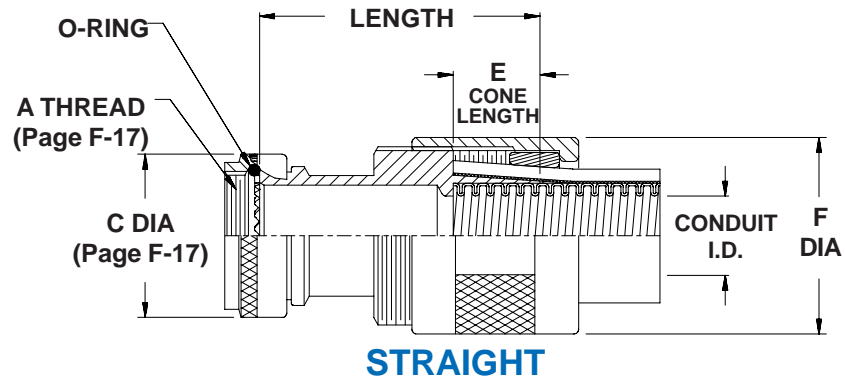

STRAIGHT

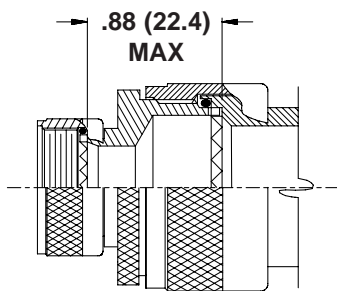

**STYLE 2
(45° & 90°)**

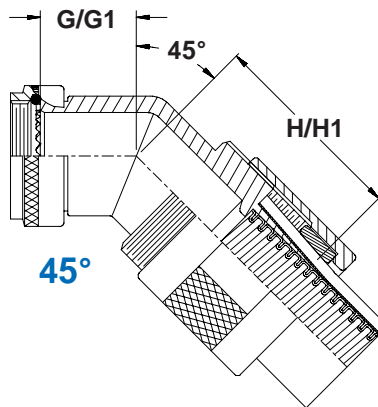

45°

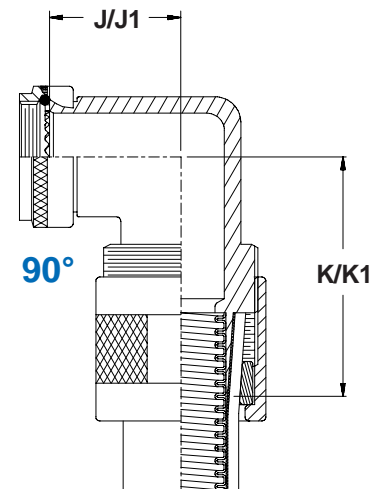

90°

712-386

Straight, 45° & 90° Environmental User-Installable Fitting for Series 75 Flexible Metal-Core Conduit

 Series 75
Metal-Core
Conduit

TABLE I

SHELLSIZE A,F,L	H	G MAX	H MAX	J MAX	K MAX
08	09	.639 (16.2)	1.700 (43.2)	.750 (19.1)	1.810 (46.0)
10	11	.654 (16.6)	1.730 (43.9)	.810 (20.6)	1.870 (47.5)
12	13	.688 (17.5)	1.750 (44.5)	.870 (22.1)	1.930 (49.0)
14	15	.705 (17.9)	1.780 (45.2)	.920 (23.4)	2.000 (50.8)
16	17	.732 (18.6)	1.800 (45.7)	.980 (24.9)	2.060 (52.3)
18	19	.748 (19.0)	1.810 (46.0)	1.020 (25.9)	2.080 (52.8)
20	21	.773 (19.6)	2.020 (51.3)	1.080 (27.4)	2.390 (60.7)
22	23	.800 (20.3)	2.060 (52.3)	1.140 (29.0)	2.470 (62.7)
24	25	.823 (20.9)	2.090 (53.1)	1.200 (30.5)	2.540 (64.5)
28		1.041 (26.4)	2.320 (58.9)	1.480 (37.6)	2.780 (70.6)
32		1.092 (27.7)	2.360 (59.9)	1.610 (40.9)	2.870 (72.9)
36		1.138 (28.9)	2.410 (61.2)	1.720 (43.7)	2.960 (75.2)
40		1.184 (30.1)	2.450 (62.2)	1.830 (46.5)	3.070 (78.0)
44		1.235 (31.4)	2.500 (63.5)	1.950 (49.5)	3.200 (81.3)
48		1.287 (32.7)	2.550 (64.8)	2.080 (52.8)	3.320 (84.3)
61		1.003 (25.5)	2.270 (57.7)	1.390 (35.3)	2.380 (60.5)

NOTES:

1. Metric dimensions (mm), are in parentheses.
2. O-Ring not supplied with connector designator A.
3. F dimension is based on type A construction. Add .125 (3.2) to listed dimensions for additional shield types B through D.
4. When tubing I.D. max exceeds inside diameter of connector shell, style 2 will be supplied. Refer to pages F-15 and F-16.

TABLE II

DASH NO.	CONDUIT I.D.	E	F MAX (NOTE 3)	G1 MAX	H1 MAX	J1 MAX	K1 MAX
08	.250 (6.4)	.75 (19.1)	1.16 (29.5)	.624 (15.8)	1.700 (43.2)	.750 (19.1)	1.810 (46.0)
12	.375 (9.5)	.75 (19.1)	1.34 (34.0)	.654 (16.6)	1.730 (43.9)	.810 (20.6)	1.870 (47.5)
16	.500 (12.7)	.75 (19.1)	1.46 (37.1)	.688 (17.5)	1.750 (44.5)	.870 (22.1)	1.930 (49.0)
20	.625 (15.9)	.75 (19.1)	1.65 (41.9)	.705 (17.9)	1.780 (45.2)	.920 (23.4)	2.000 (50.8)
24	.750 (19.1)	.75 (19.1)	1.84 (46.7)	.732 (18.6)	1.800 (45.7)	.980 (24.9)	2.060 (52.3)
32	1.000 (25.4)	1.00 (25.4)	2.02 (51.3)	.773 (19.6)	2.020 (51.3)	1.080 (27.4)	2.390 (60.7)
40	1.250 (31.8)	1.00 (25.4)	2.34 (59.4)	.823 (20.9)	2.090 (53.1)	1.200 (30.5)	2.540 (64.5)
48	1.500 (38.1)	1.00 (25.4)	2.72 (69.1)	1.041 (26.4)	2.360 (59.9)	1.480 (37.6)	2.870 (72.9)
56	1.750 (44.5)	1.00 (25.4)	2.96 (75.2)	1.062 (27.0)	2.410 (61.2)	1.550 (39.4)	2.960 (75.2)
64	2.000 (50.8)	1.00 (25.4)	3.22 (81.8)	1.092 (27.7)	2.450 (62.2)	1.610 (40.9)	3.070 (78.0)
80	2.500 (63.5)	1.00 (25.4)	3.86 (98.0)	1.190 (30.2)	2.550 (64.8)	1.860 (47.2)	3.320 (84.3)
96	3.000 (76.2)	1.00 (25.4)	4.38 (111.3)	1.250 (31.8)	2.610 (66.3)	1.990 (50.5)	3.450 (87.6)

TABLE III

SYMBOL	MATERIAL	FINISH
A	Aluminum Alloy, 6061-T6 per QQ-A-225/8	Cadmium, Olive Drab, per QQ-P-416, over Electroless Nickel per ASTM B733-90, and MIL-C-26074, 500 Hour Salt Spray
B	Brass, ASTM B16 per QQ-B-626	
C	Corrosion Resistant Steel per QQ-S-763, 300 Series	Passivate per QQ-P-35
M	Aluminum Alloy, 6061-T6 per QQ-A-225/8	Electroless Nickel per ASTM B733-90 and MIL-C-26074
NC	Aluminum Alloy, 6061-T6 per QQ-A-225/8	Zinc Cobalt, Olive Drab
S	Carbon Steel, B1113, per QQ-S-637	Cadmium, Olive Drab per QQ-P-416, over Electroless Nickel per ASTM B733-90 and MIL-C-26074, 500 Hour Salt Spray