

SN54121, SN74121
MONOSTABLE MULTIVIBRATORS
WITH SCHMITT-TRIGGER INPUTS

MAY 1983 — REVISED MARCH 1988

- Programmable Output Pulse Width
 With R_{int} . . . 35 ns Typ
 With R_{ext}/C_{ext} . . . 40 ns to 28 Seconds
- Internal Compensation for Virtual Temperature Independence
- Jitter-Free Operation up to 90% Duty Cycle
- Inhibit Capability

SN54121 . . . J OR W PACKAGE
 SN74121 . . . N PACKAGE
 (TOP VIEW)

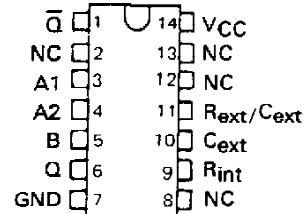

NC - No internal connection.

FUNCTION TABLE

INPUTS			OUTPUTS	
A1	A2	B	Q	Q̄
L	X	H	L	H
X	L	H	L↑	H↑
X	X	L	L↑	H↑
H	H	X	L↑	H↑
H	↓	H	[Pulse]	[Pulse]
↓	H	H	[Pulse]	[Pulse]
↓	↓	H	[Pulse]	[Pulse]
L	X	↑	[Pulse]	[Pulse]
X	L	↑	[Pulse]	[Pulse]

For explanation of function table symbols, see page

† These lines of the function table assume that the indicated steady-state conditions at the A and B inputs have been setup long enough to complete any pulse started before the setup.

logic symbol†

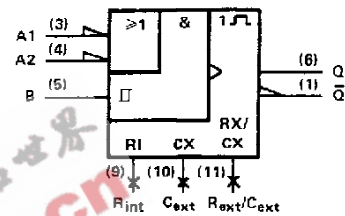

† This symbol is in accordance with ANSI/IEEE Std 91-1984 and IEC Publication 617-12.

description

These multivibrators feature dual negative-transition-triggered inputs and a single positive-transition-triggered input which can be used as an inhibit input. Complementary output pulses are provided.

Pulse triggering occurs at a particular voltage level and is not directly related to the transition time of the input pulse. Schmitt-trigger input circuitry (TTL hysteresis) for the B input allows jitter-free triggering from inputs with transition rates as slow as 1 volt/second, providing the circuit with an excellent noise immunity of typically 1.2 volts. A high immunity to V_{CC} noise of typically 1.5 volts is also provided by internal latching circuitry.

Once fired, the outputs are independent of further transitions of the inputs and are a function only of the timing components. Input pulses may be of any duration relative to the output pulse. Output pulse length may be varied from 40 nanoseconds to 28 seconds by choosing appropriate timing components. With no external timing components (i.e., R_{int} connected to V_{CC} , C_{ext} and R_{ext}/C_{ext} open), an output pulse of typically 30 or 35 nanoseconds is achieved which may be used as a d-c triggered reset signal. Output rise and fall times are TTL compatible and independent of pulse length.

Pulse width stability is achieved through internal compensation and is virtually independent of V_{CC} and temperature. In most applications, pulse stability will only be limited by the accuracy of external timing components.

Jitter-free operation is maintained over the full temperature and V_{CC} ranges for more than six decades of timing capacitance (10 pF to 10 μ F) and more than one decade of timing resistance (2 k Ω to 30 k Ω for the SN54121 and 2 k Ω to 40 k Ω for the SN74121). Throughout these ranges, pulse width is defined by the relationship $t_{w(out)} = C_{ext}R_T \ln 2 \approx 0.7 C_{ext}R_T$. In circuits where pulse cutoff is not critical, timing capacitance up to 1000 μ F and timing resistance as low as 1.4 k Ω may be used. Also, the range of jitter-free output pulse widths is extended if V_{CC} is held to 5 volts and free-air temperature is 25°C. Duty cycles as high as 90% are achieved when using maximum recommended R_T . Higher duty cycles are available if a certain amount of pulse-width jitter is allowed.

PRODUCTION DATA documents contain information current as of publication date. Products conform to specifications per the terms of Texas Instruments standard warranty. Production processing does not necessarily include testing of all parameters.



SN54121, SN74121 MONOSTABLE MULTIVIBRATORS WITH SCHMITT-TRIGGER INPUTS

logic diagram (positive logic)

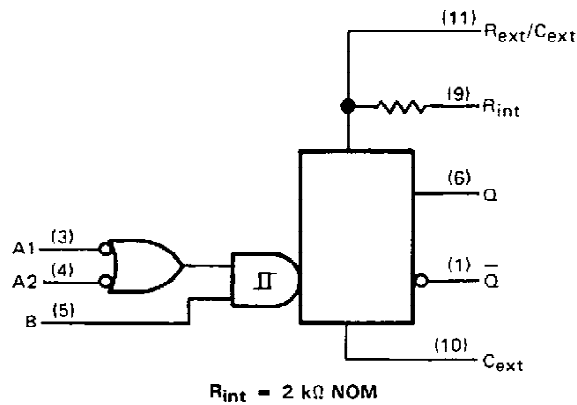

Pin numbers shown on logic notation are for J or N packages.

- NOTES: 1. An external capacitor may be connected between C_{ext} (positive) and R_{ext}/C_{ext} .
 2. To use the internal timing resistor, connect R_{int} to V_{CC} . For improved pulse width accuracy and repeatability, connect an external resistor between R_{ext}/C_{ext} and V_{CC} with R_{int} open-circuited.

schematics of inputs and outputs

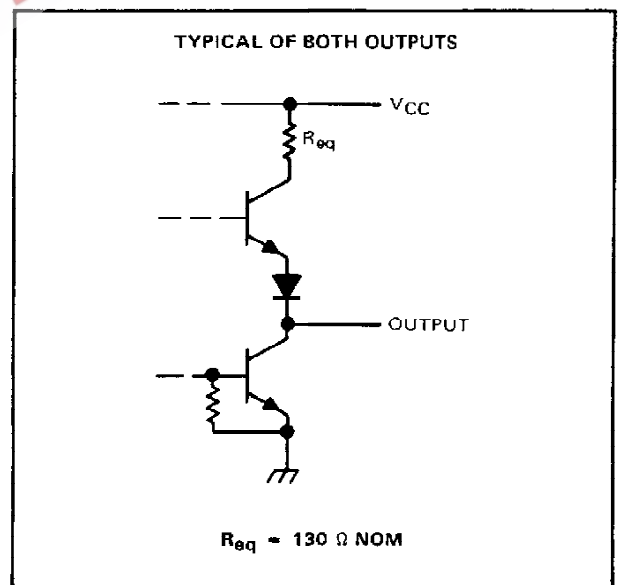
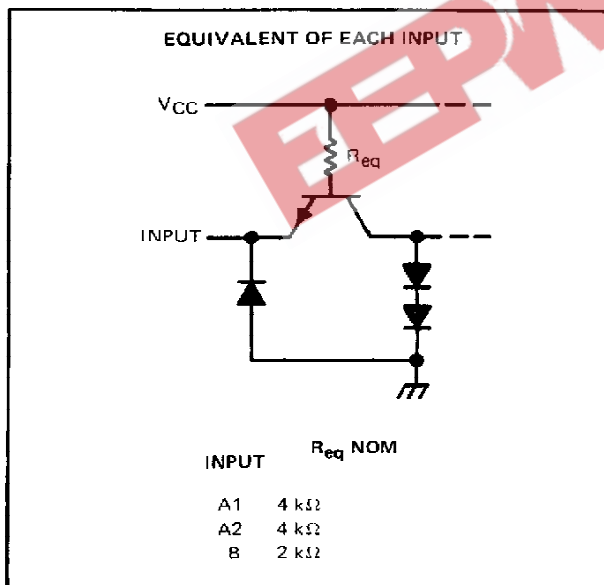

SN54121, SN74121
MONOSTABLE MULTIVIBRATORS
WITH SCHMITT-TRIGGER INPUTS

absolute maximum ratings over operating free-air temperature range (unless otherwise noted)

Supply voltage, V_{CC} (see Note 3)	7 V
Input voltage	5.5 V
Operating free-air temperature range: SN54121	-55°C to 125°C
SN74121	0°C to 70°C
Storage temperature range	-65°C to 150°C

NOTE 3: Voltage values are with respect to network ground terminal.

recommended operating conditions

		MIN	NOM	MAX	UNIT	
V_{CC}	Supply voltage	54 Family	4.5	5	5.5	V
		74 Family	4.75	5	5.25	
I_{OH}	High-level output current			-0.4	mA	
I_{OL}	Low-level output current			16	mA	
dv/dt	Rate of rise or fall of input pulse	Schmitt input, B	1		V/s	
		Logic inputs, A1, A2	1		V/ μ s	
$t_{w(in)}$	Input pulse width	50			ns	
R_{ext}	External timing capacitance	54 Family	1.4	30	k Ω	
		74 Family	1.4	40		
C_{ext}	External timing capacitance	0	1000		μ F	
	Duty cycle	$R_T = 2 \text{ k}\Omega$		67	%	
		$R_T = \text{MAX } R_{ext}$		90		
T_A	Operating free-air temperature	54 Family	-55	125	°C	
		74 Family	0	70		



SN54121, SN74121 MONOSTABLE MULTIVIBRATORS WITH SCHMITT-TRIGGER INPUTS

electrical characteristics over recommended operating free-air temperature range (unless otherwise noted)

PARAMETER	TEST CONDITIONS [†]	MIN	TYP [‡]	MAX	UNIT	
V _{IH}	High-level input voltage at B input	V _{CC} = MIN	2		V	
V _{IL}	Low-level input voltage at A input	V _{CC} = MIN		0.8	V	
V _{T+}	Positive-going threshold voltage at B input	V _{CC} = MIN	1.55	2	V	
V _{T-}	Negative-going threshold voltage at B input	V _{CC} = MIN	0.8	1.35	V	
V _{IK}	Input clamp voltage	V _{CC} = MIN, I _I = -12 mA		-1.5	V	
I _{OH}	High-level output voltage	V _{CC} = MIN, I _{OH} = MAX	2.4	3.4	V	
V _{OL}	Low-level output voltage	V _{CC} = MIN, I _{OL} = MAX	0.2	0.4	V	
I _I	Input current at maximum input voltage	V _{CC} = MAX, V _I = 5.5 V		1	mA	
I _{IH}	High-level input current	V _{CC} = MAX, V _I = 2.4 V	A1 or A2		40	μA
			B		80	
I _{IL}	Low-level input current	V _{CC} = MAX, V _I = 0.4 V	A1 or A2		-1.6	mA
			B		-3.2	
I _{OS}	Short-circuit output current [§]	V _{CC} = MAX	54 Family	-20	-55	mA
			74 Family	-18	-55	
I _{CC}	Supply current	V _{CC} = MAX	Quiescent	13	25	mA
			Triggered	23	40	

[†]For conditions shown as MIN or MAX, use the appropriate value specified under recommended operating conditions.

[‡]All typical values are at V_{CC} = 5 V, T_A = 25°C.

[§]Not more than one output should be shorted at a time.

switching characteristics, V_{CC} = 5 V, T_A = 25°C

PARAMETER	TEST CONDITIONS	MIN	TYP	MAX	UNIT	
t _{PLH}	C _L = 15 pF, R _L = 400 Ω, See Note 4	C _{ext} = 80 pF, R _{int} to V _{CC}	45	70	ns	
t _{PLH}			35	55	ns	
t _{PHL}			50	80	ns	
t _{PHL}			40	65	ns	
t _{w(out)}		C _{ext} = 80 pF, R _{int} to V _{CC}	70	110	150	ns
t _{w(out)}		C _{ext} = 0, R _{int} to V _{CC}	30	50	ns	
t _{w(out)}		C _{ext} = 100 pF, R _T = 10 kΩ	600	700	800	ns
		C _{ext} = 1 μF, R _T = 10 kΩ	6	7	8	ms

NOTE 4: Load circuits and voltage waveforms are shown in Section 1.

TEXAS
INSTRUMENTS

POST OFFICE BOX 655012 • DALLAS, TEXAS 75265

SN54121, SN74121
MONOSTABLE MULTIVIBRATORS
WITH SCHMITT-TRIGGER INPUTS

TYPICAL CHARACTERISTICS†

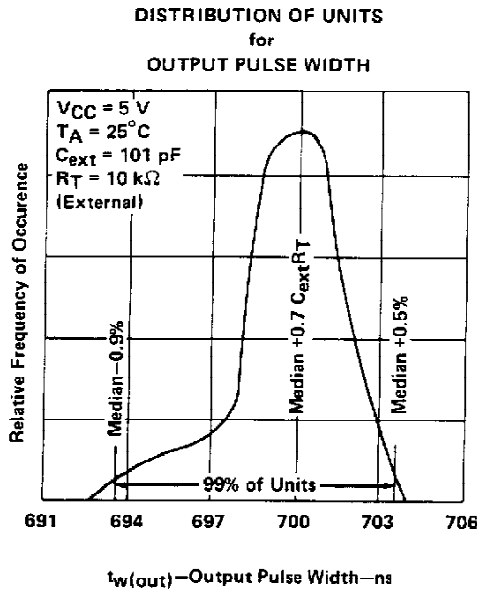

FIGURE 1

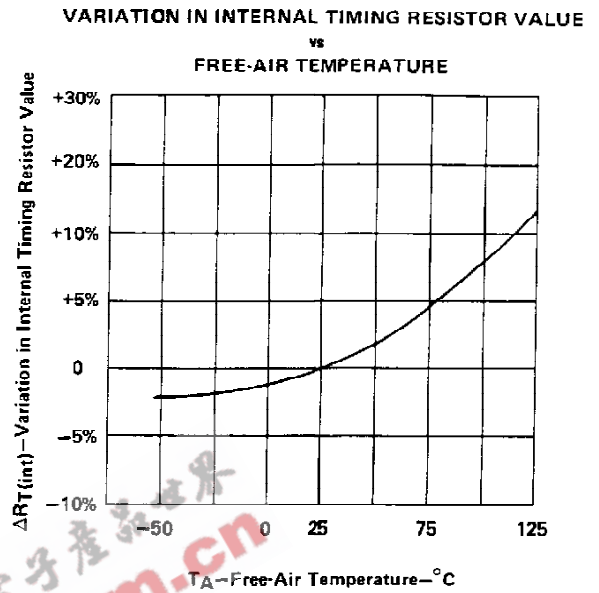

FIGURE 2

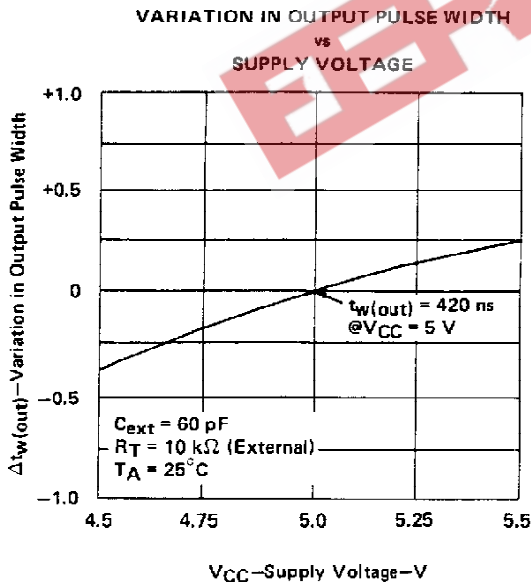

FIGURE 3

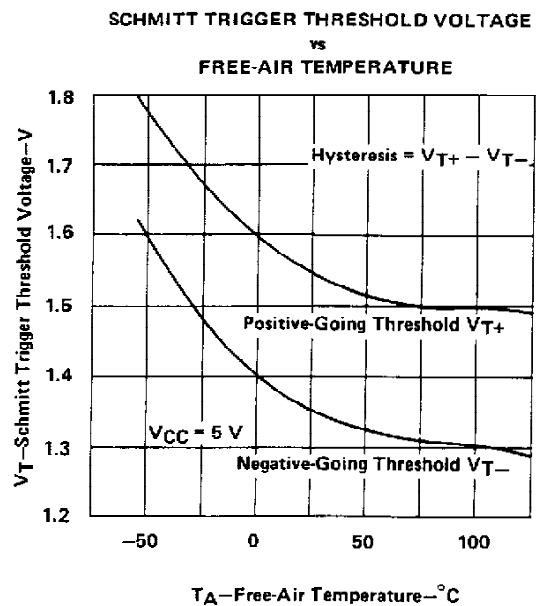

FIGURE 4

†Data for temperatures below 0°C and above 70°C are applicable for SN54121.

SN54121, SN74121
MONOSTABLE MULTIVIBRATORS
WITH SCHMITT-TRIGGER INPUTS

TYPICAL CHARACTERISTICS† (continued)

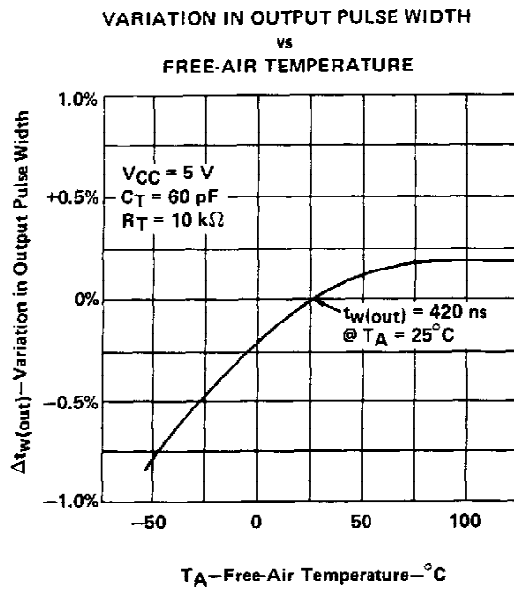

FIGURE 5

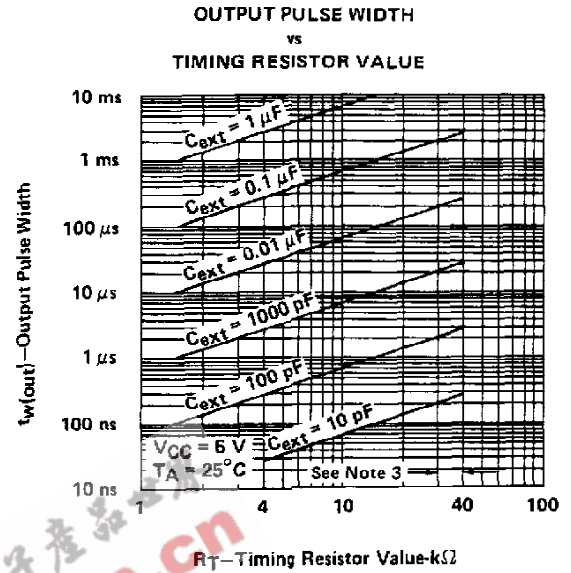

FIGURE 6

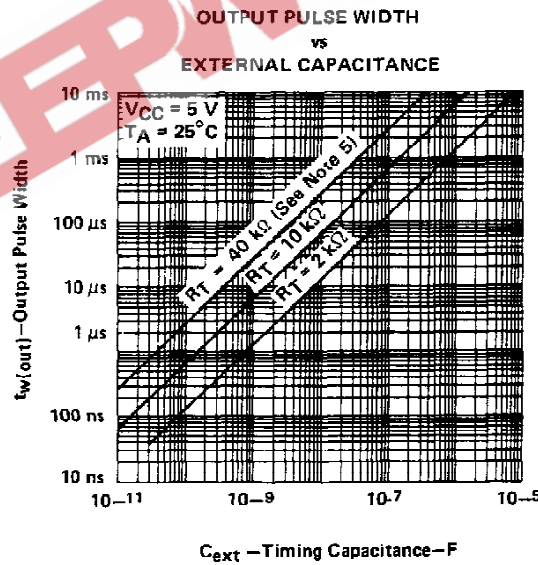

FIGURE 7

NOTE 5: These values of resistance exceed the maximum recommended use over the full temperature range of the SN54121.
 †Data for temperatures below 0°C and above 70°C are applicable for SN54121.

IMPORTANT NOTICE

Texas Instruments (TI) reserves the right to make changes to its products or to discontinue any semiconductor product or service without notice, and advises its customers to obtain the latest version of relevant information to verify, before placing orders, that the information being relied on is current.

TI warrants performance of its semiconductor products and related software to the specifications applicable at the time of sale in accordance with TI's standard warranty. Testing and other quality control techniques are utilized to the extent TI deems necessary to support this warranty. Specific testing of all parameters of each device is not necessarily performed, except those mandated by government requirements.

Certain applications using semiconductor products may involve potential risks of death, personal injury, or severe property or environmental damage ("Critical Applications").

TI SEMICONDUCTOR PRODUCTS ARE NOT DESIGNED, INTENDED, AUTHORIZED, OR WARRANTED TO BE SUITABLE FOR USE IN LIFE-SUPPORT APPLICATIONS, DEVICES OR SYSTEMS OR OTHER CRITICAL APPLICATIONS.

Inclusion of TI products in such applications is understood to be fully at the risk of the customer. Use of TI products in such applications requires the written approval of an appropriate TI officer. Questions concerning potential risk applications should be directed to TI through a local SC sales office.

In order to minimize risks associated with the customer's applications, adequate design and operating safeguards should be provided by the customer to minimize inherent or procedural hazards.

TI assumes no liability for applications assistance, customer product design, software performance, or infringement of patents or services described herein. Nor does TI warrant or represent that any license, either express or implied, is granted under any patent right, copyright, mask work right, or other intellectual property right of TI covering or relating to any combination, machine, or process in which such semiconductor products or services might be or are used.

PACKAGING INFORMATION

Orderable Device	Status ⁽¹⁾	Package Type	Package Drawing	Pins	Package Qty	Eco Plan ⁽²⁾	Lead/Ball Finish	MSL Peak Temp ⁽³⁾
5962-9755301QCA	ACTIVE	CDIP	J	14	1	TBD	Call TI	Level-NC-NC-NC
5962-9755301QDA	ACTIVE	CFP	W	14	1	TBD	Call TI	Level-NC-NC-NC
SN54121J	ACTIVE	CDIP	J	14	1	TBD	Call TI	Level-NC-NC-NC
SN74121D	ACTIVE	SOIC	D	14	50	Green (RoHS & no Sb/Br)	CU NIPDAU	Level-1-260C-UNLIM
SN74121DE4	ACTIVE	SOIC	D	14	50	Green (RoHS & no Sb/Br)	CU NIPDAU	Level-1-260C-UNLIM
SN74121DR	ACTIVE	SOIC	D	14	2500	Green (RoHS & no Sb/Br)	CU NIPDAU	Level-1-260C-UNLIM
SN74121DRE4	ACTIVE	SOIC	D	14	2500	Green (RoHS & no Sb/Br)	CU NIPDAU	Level-1-260C-UNLIM
SN74121N	ACTIVE	PDIP	N	14	25	Pb-Free (RoHS)	CU NIPDAU	Level-NC-NC-NC
SN74121N3	OBSOLETE	PDIP	N	14		TBD	Call TI	Call TI
SN74121NE4	ACTIVE	PDIP	N	14	25	Pb-Free (RoHS)	CU NIPDAU	Level-NC-NC-NC
SN74121NSR	ACTIVE	SO	NS	14	2000	Green (RoHS & no Sb/Br)	CU NIPDAU	Level-1-260C-UNLIM
SN74121NSRE4	ACTIVE	SO	NS	14	2000	Green (RoHS & no Sb/Br)	CU NIPDAU	Level-1-260C-UNLIM
SNJ54121J	ACTIVE	CDIP	J	14	1	TBD	Call TI	Level-NC-NC-NC
SNJ54121W	ACTIVE	CFP	W	14	1	TBD	Call TI	Level-NC-NC-NC
SNJ54121WA	ACTIVE	CFP	WA	14	1	TBD	Call TI	Level-NC-NC-NC

⁽¹⁾ The marketing status values are defined as follows:

ACTIVE: Product device recommended for new designs.

LIFEBUY: TI has announced that the device will be discontinued, and a lifetime-buy period is in effect.

NRND: Not recommended for new designs. Device is in production to support existing customers, but TI does not recommend using this part in a new design.

PREVIEW: Device has been announced but is not in production. Samples may or may not be available.

OBSOLETE: TI has discontinued the production of the device.

⁽²⁾ Eco Plan - The planned eco-friendly classification: Pb-Free (RoHS) or Green (RoHS & no Sb/Br) - please check <http://www.ti.com/productcontent> for the latest availability information and additional product content details.

TBD: The Pb-Free/Green conversion plan has not been defined.

Pb-Free (RoHS): TI's terms "Lead-Free" or "Pb-Free" mean semiconductor products that are compatible with the current RoHS requirements for all 6 substances, including the requirement that lead not exceed 0.1% by weight in homogeneous materials. Where designed to be soldered at high temperatures, TI Pb-Free products are suitable for use in specified lead-free processes.

Green (RoHS & no Sb/Br): TI defines "Green" to mean Pb-Free (RoHS compatible), and free of Bromine (Br) and Antimony (Sb) based flame retardants (Br or Sb do not exceed 0.1% by weight in homogeneous material)

⁽³⁾ MSL, Peak Temp. -- The Moisture Sensitivity Level rating according to the JEDEC industry standard classifications, and peak solder temperature.

Important Information and Disclaimer:The information provided on this page represents TI's knowledge and belief as of the date that it is provided. TI bases its knowledge and belief on information provided by third parties, and makes no representation or warranty as to the accuracy of such information. Efforts are underway to better integrate information from third parties. TI has taken and continues to take reasonable steps to provide representative and accurate information but may not have conducted destructive testing or chemical analysis on incoming materials and chemicals. TI and TI suppliers consider certain information to be proprietary, and thus CAS numbers and other limited information may not be available for release.

In no event shall TI's liability arising out of such information exceed the total purchase price of the TI part(s) at issue in this document sold by TI

to Customer on an annual basis.

EEPW 电子產品世界
.com.cn

J (R-GDIP-T**)
14 LEADS SHOWN

CERAMIC DUAL IN-LINE PACKAGE

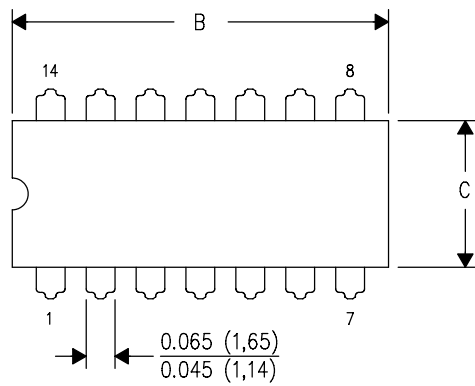

DIM \ PINS **	14	16	18	20
A	0.300 (7,62) BSC	0.300 (7,62) BSC	0.300 (7,62) BSC	0.300 (7,62) BSC
B MAX	0.785 (19,94)	.840 (21,34)	0.960 (24,38)	1.060 (26,92)
B MIN	—	—	—	—
C MAX	0.300 (7,62)	0.300 (7,62)	0.310 (7,87)	0.300 (7,62)
C MIN	0.245 (6,22)	0.245 (6,22)	0.220 (5,59)	0.245 (6,22)

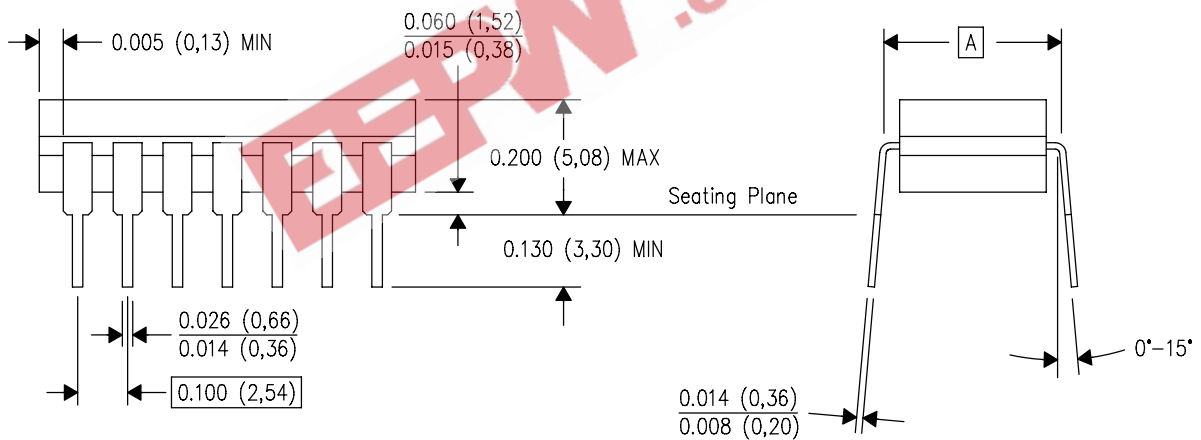

4040083/F 03/03

- NOTES:
- All linear dimensions are in inches (millimeters).
 - This drawing is subject to change without notice.
 - This package is hermetically sealed with a ceramic lid using glass frit.
 - Index point is provided on cap for terminal identification only on press ceramic glass frit seal only.
 - Falls within MIL STD 1835 GDIP1-T14, GDIP1-T16, GDIP1-T18 and GDIP1-T20.

MECHANICAL DATA

W (R-GDFP-F14)

CERAMIC DUAL FLATPACK

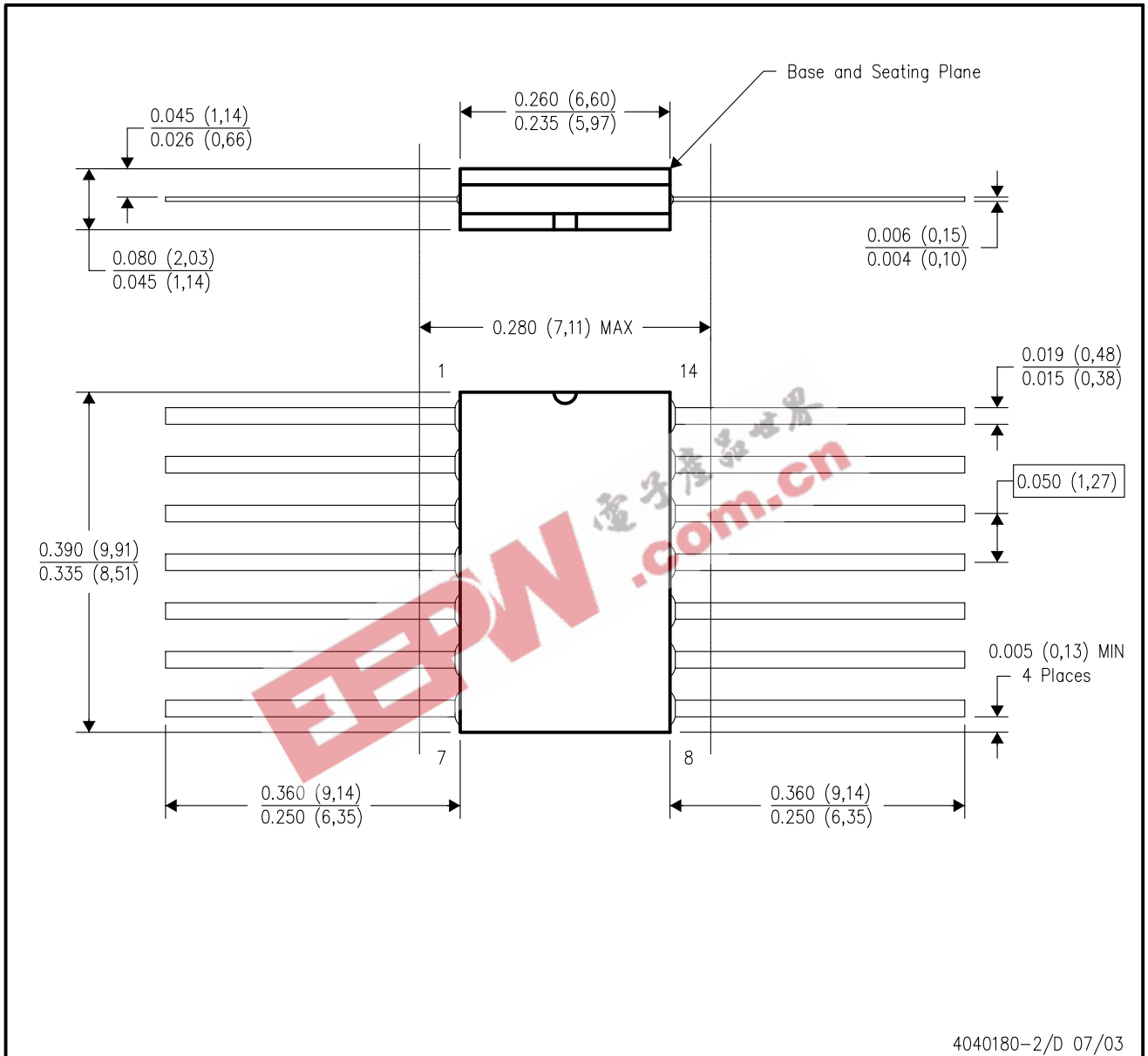

- NOTES:
- All linear dimensions are in inches (millimeters).
 - This drawing is subject to change without notice.
 - This package can be hermetically sealed with a ceramic lid using glass frit.
 - Index point is provided on cap for terminal identification only.
 - Falls within MIL STD 1835 GDFP1-F14 and JEDEC MO-092AB

MECHANICAL DATA

N (R-PDIP-T**)

PLASTIC DUAL-IN-LINE PACKAGE

16 PINS SHOWN

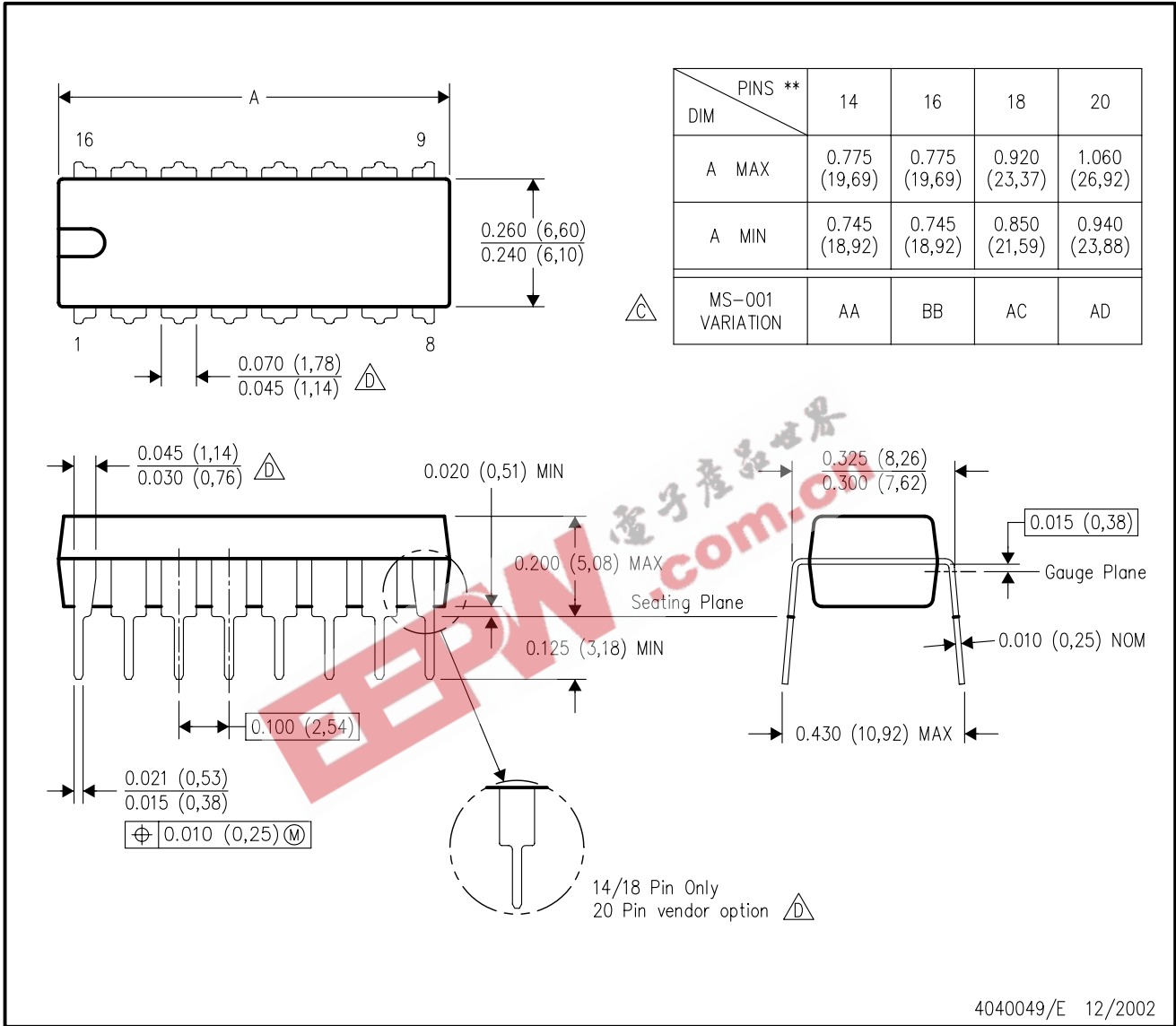

- NOTES:
- A. All linear dimensions are in inches (millimeters).
 - B. This drawing is subject to change without notice.
 - Falls within JEDEC MS-001, except 18 and 20 pin minimum body length (Dim A).
 - The 20 pin end lead shoulder width is a vendor option, either half or full width.

MECHANICAL DATA

D (R-PDSO-G14)

PLASTIC SMALL-OUTLINE PACKAGE

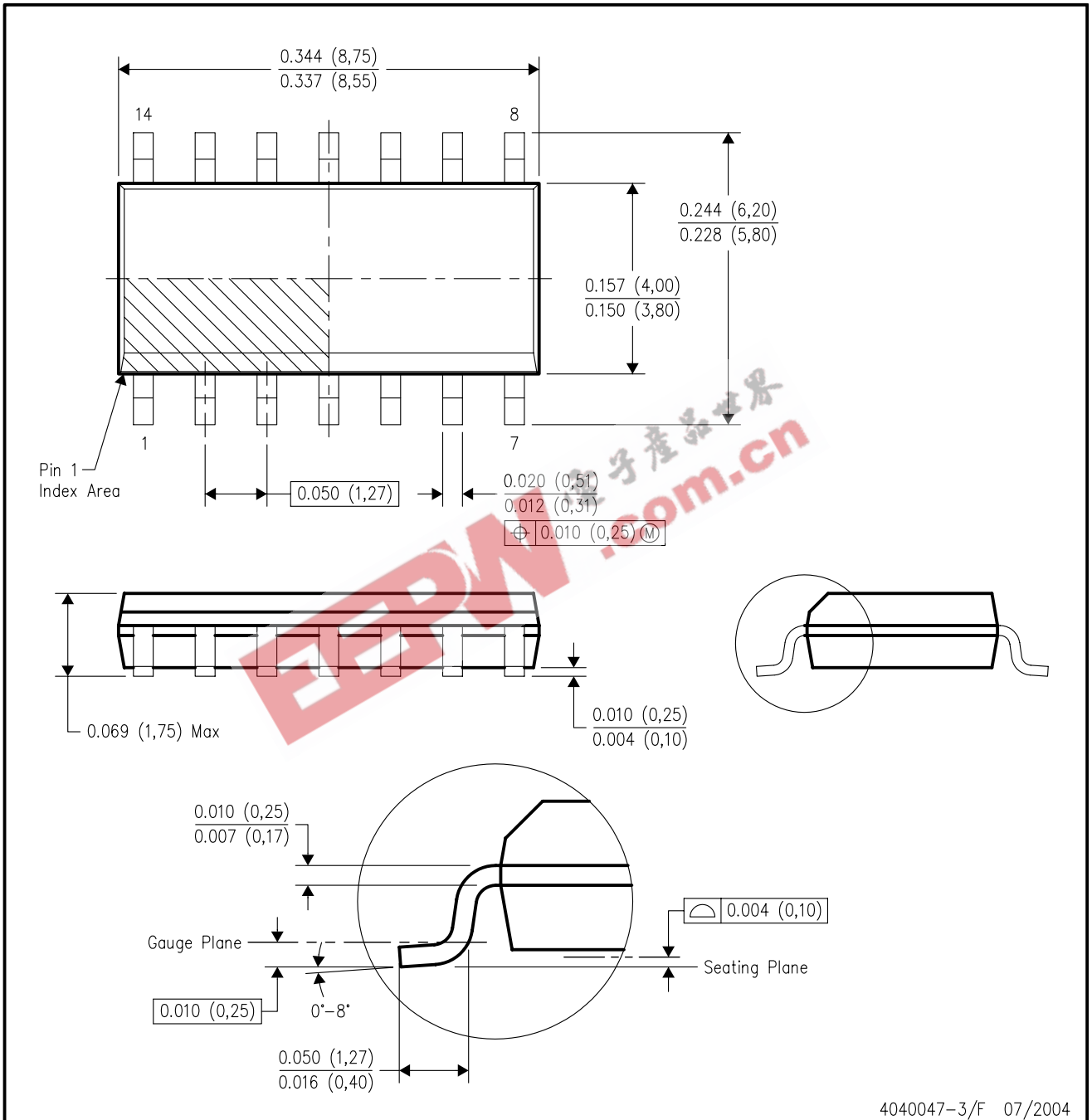

4040047-3/F 07/2004

- NOTES:
- A. All linear dimensions are in inches (millimeters).
 - B. This drawing is subject to change without notice.
 - C. Body dimensions do not include mold flash or protrusion not to exceed 0.006 (0,15).
 - D. Falls within JEDEC MS-012 variation AB.

MECHANICAL DATA

NS (R-PDSO-G)**

PLASTIC SMALL-OUTLINE PACKAGE

14-PINS SHOWN

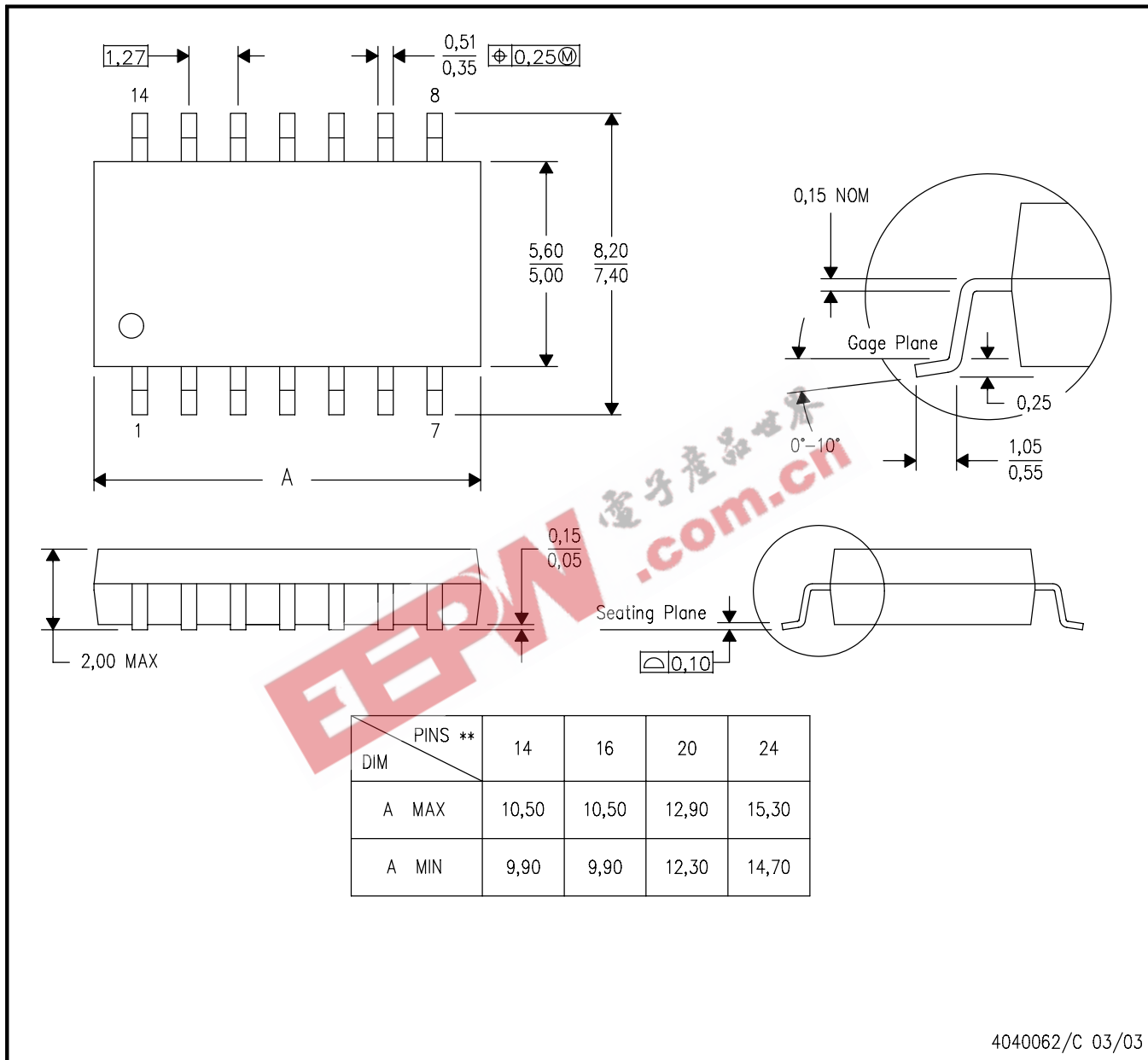

4040062/C 03/03

- NOTES:
- All linear dimensions are in millimeters.
 - This drawing is subject to change without notice.
 - Body dimensions do not include mold flash or protrusion, not to exceed 0,15.

IMPORTANT NOTICE

Texas Instruments Incorporated and its subsidiaries (TI) reserve the right to make corrections, modifications, enhancements, improvements, and other changes to its products and services at any time and to discontinue any product or service without notice. Customers should obtain the latest relevant information before placing orders and should verify that such information is current and complete. All products are sold subject to TI's terms and conditions of sale supplied at the time of order acknowledgment.

TI warrants performance of its hardware products to the specifications applicable at the time of sale in accordance with TI's standard warranty. Testing and other quality control techniques are used to the extent TI deems necessary to support this warranty. Except where mandated by government requirements, testing of all parameters of each product is not necessarily performed.

TI assumes no liability for applications assistance or customer product design. Customers are responsible for their products and applications using TI components. To minimize the risks associated with customer products and applications, customers should provide adequate design and operating safeguards.

TI does not warrant or represent that any license, either express or implied, is granted under any TI patent right, copyright, mask work right, or other TI intellectual property right relating to any combination, machine, or process in which TI products or services are used. Information published by TI regarding third-party products or services does not constitute a license from TI to use such products or services or a warranty or endorsement thereof. Use of such information may require a license from a third party under the patents or other intellectual property of the third party, or a license from TI under the patents or other intellectual property of TI.

Reproduction of information in TI data books or data sheets is permissible only if reproduction is without alteration and is accompanied by all associated warranties, conditions, limitations, and notices. Reproduction of this information with alteration is an unfair and deceptive business practice. TI is not responsible or liable for such altered documentation.

Resale of TI products or services with statements different from or beyond the parameters stated by TI for that product or service voids all express and any implied warranties for the associated TI product or service and is an unfair and deceptive business practice. TI is not responsible or liable for any such statements.

Following are URLs where you can obtain information on other Texas Instruments products and application solutions:

Products		Applications	
Amplifiers	amplifier.ti.com	Audio	www.ti.com/audio
Data Converters	dataconverter.ti.com	Automotive	www.ti.com/automotive
DSP	dsp.ti.com	Broadband	www.ti.com/broadband
Interface	interface.ti.com	Digital Control	www.ti.com/digitalcontrol
Logic	logic.ti.com	Military	www.ti.com/military
Power Mgmt	power.ti.com	Optical Networking	www.ti.com/opticalnetwork
Microcontrollers	microcontroller.ti.com	Security	www.ti.com/security
		Telephony	www.ti.com/telephony
		Video & Imaging	www.ti.com/video
		Wireless	www.ti.com/wireless

Mailing Address: Texas Instruments
Post Office Box 655303 Dallas, Texas 75265