

## DM74LS138 • DM74LS139 Decoder/Demultiplexer

### General Description

These Schottky-clamped circuits are designed to be used in high-performance memory-decoding or data-routing applications, requiring very short propagation delay times. In high-performance memory systems these decoders can be used to minimize the effects of system decoding. When used with high-speed memories, the delay times of these decoders are usually less than the typical access time of the memory. This means that the effective system delay introduced by the decoder is negligible.

The DM74LS138 decodes one-of-eight lines, based upon the conditions at the three binary select inputs and the three enable inputs. Two active-low and one active-high enable inputs reduce the need for external gates or inverters when expanding. A 24-line decoder can be implemented with no external inverters, and a 32-line decoder requires only one inverter. An enable input can be used as a data input for demultiplexing applications.

The DM74LS139 comprises two separate two-line-to-four-line decoders in a single package. The active-low enable input can be used as a data line in demultiplexing applications.

All of these decoders/demultiplexers feature fully buffered inputs, presenting only one normalized load to its driving circuit. All inputs are clamped with high-performance Schottky diodes to suppress line-ringing and simplify system design.

### Features

- Designed specifically for high speed:
  - Memory decoders
  - Data transmission systems
- DM74LS138 3-to-8-line decoders incorporates 3 enable inputs to simplify cascading and/or data reception
- DM74LS139 contains two fully independent 2-to-4-line decoders/demultiplexers
- Schottky clamped for high performance
- Typical propagation delay (3 levels of logic)
  - DM74LS138 21 ns
  - DM74LS139 21 ns
- Typical power dissipation
  - DM74LS138 32 mW
  - DM74LS139 34 mW

### Ordering Code:

Order Number	Package Number	Package Description
DM74LS138M	M16A	16-Lead Small Outline Integrated Circuit (SOIC), JEDEC MS-012, 0.150 Narrow
DM74LS138SJ	M16D	16-Lead Small Outline Package (SOP), EIAJ TYPE II, 5.3mm Wide
DM74LS138N	N16E	16-Lead Plastic Dual-In-Line Package (PDIP), JEDEC MS-001, 0.300 Wide
DM74LS139M	M16A	16-Lead Small Outline Integrated Circuit (SOIC), JEDEC MS-012, 0.150 Narrow
DM74LS139SJ	M16D	16-Lead Small Outline Package (SOP), EIAJ TYPE II, 5.3mm Wide
DM74LS139N	N16E	16-Lead Plastic Dual-In-Line Package (PDIP), JEDEC MS-001, 0.300 Wide

Devices also available in Tape and Reel. Specify by appending the suffix letter "X" to the ordering code.

### Connection Diagrams

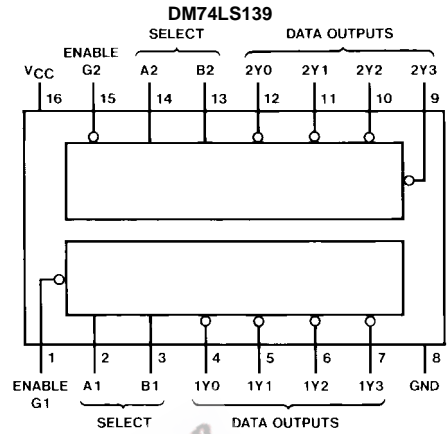
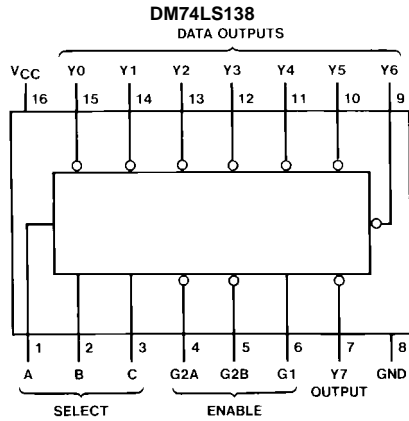

### Function Tables

DM74LS138

Inputs		Outputs												
Enable		Select												
G1	G2 (Note 1)	C	B	A	Y0	Y1	Y2	Y3	Y4	Y5	Y6	Y7		
X	H	X	X	X	H	H	H	H	H	H	H	H		
L	X	X	X	X	H	H	H	H	H	H	H	H		
H	L	L	L	L	H	H	H	H	H	H	H	H		
H	L	L	L	H	H	L	H	H	H	H	H	H		
H	L	L	H	L	H	H	L	H	H	H	H	H		
H	L	L	H	H	H	H	L	H	H	H	H	H		
H	L	H	L	L	H	H	H	L	H	H	H	H		
H	L	H	L	H	H	H	H	L	H	L	H	H		
H	L	H	H	L	H	H	H	H	L	L	H	H		
H	L	H	H	H	H	H	H	H	H	L	L	L		

DM74LS139

Inputs		Outputs							
Enable		Select							
G	B	A	Y0	Y1	Y2	Y3			
H	X	X	H	H	H	H			
L	L	L	L	H	H	H			
L	L	H	H	L	H	H			
L	H	L	H	H	L	H			
L	H	H	H	H	H	L			

H = HIGH Level  
L = LOW Level  
X = Don't Care

Note 1: G2 = G2A + G2B

### Logic Diagrams

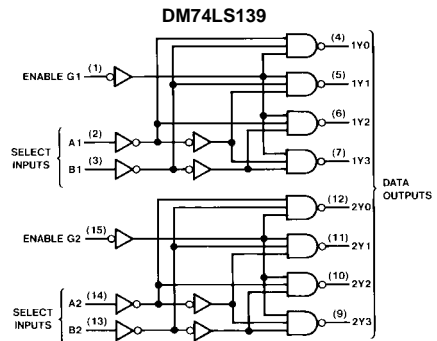
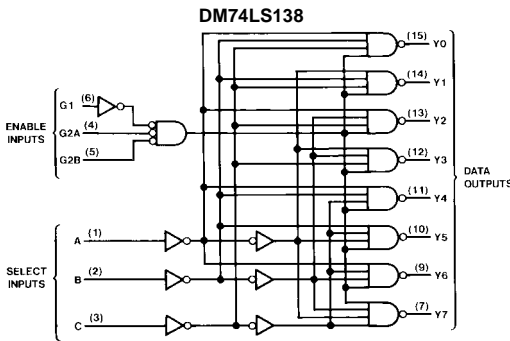

**Absolute Maximum Ratings**(Note 2)

Supply Voltage	7V
Input Voltage	7V
Operating Free Air Temperature Range	0°C to +70°C
Storage Temperature Range	-65°C to +150°C

**Note 2:** The "Absolute Maximum Ratings" are those values beyond which the safety of the device cannot be guaranteed. The device should not be operated at these limits. The parametric values defined in the Electrical Characteristics tables are not guaranteed at the absolute maximum ratings. The "Recommended Operating Conditions" table will define the conditions for actual device operation.

**DM74LS138 Recommended Operating Conditions**

Symbol	Parameter	Min	Nom	Max	Units
$V_{CC}$	Supply Voltage	4.75	5	5.25	V
$V_{IH}$	HIGH Level Input Voltage	2			V
$V_{IL}$	LOW Level Input Voltage			0.8	V
$I_{OH}$	HIGH Level Output Current			-0.4	mA
$I_{OL}$	LOW Level Output Current			8	mA
$T_A$	Free Air Operating Temperature	0		70	°C

**DM74LS138 Electrical Characteristics**

over recommended operating free air temperature range (unless otherwise noted)

Symbol	Parameter	Conditions	Min	Typ (Note 3)	Max	Units
$V_I$	Input Clamp Voltage	$V_{CC} = \text{Min}, I_I = -18 \text{ mA}$			-1.5	V
$V_{OH}$	HIGH Level Output Voltage	$V_{CC} = \text{Min}, I_{OH} = \text{Max}, V_{IL} = \text{Max}, V_{IH} = \text{Min}$	2.7	3.4		V
$V_{OL}$	LOW Level	$V_{CC} = \text{Min}, I_{OL} = \text{Max}, V_{IL} = \text{Max}, V_{IH} = \text{Min}$		0.35	0.5	V
	Output Voltage	$I_{OL} = 4 \text{ mA}, V_{CC} = \text{Min}$		0.25	0.4	
$I_I$	Input Current @ Max Input Voltage	$V_{CC} = \text{Max}, V_I = 7V$			0.1	mA
$I_{IH}$	HIGH Level Input Current	$V_{CC} = \text{Max}, V_I = 2.7V$			20	$\mu\text{A}$
$I_{IL}$	LOW Level Input Current	$V_{CC} = \text{Max}, V_I = 0.4V$			-0.36	mA
$I_{OS}$	Short Circuit Output Current	$V_{CC} = \text{Max}$ (Note 4)	-20		-100	mA
$I_{CC}$	Supply Current	$V_{CC} = \text{Max}$ (Note 5)		6.3	10	mA

**Note 3:** All typicals are at  $V_{CC} = 5V, T_A = 25^\circ\text{C}$ .

**Note 4:** Not more than one output should be shorted at a time, and the duration should not exceed one second.

**Note 5:**  $I_{CC}$  is measured with all outputs enabled and OPEN.

**DM74LS138 Switching Characteristics**

at  $V_{CC} = 5V$  and  $T_A = 25^\circ\text{C}$

Symbol	Parameter	From (Input) To (Output)	Levels of Delay	$R_L = 2 \text{ k}\Omega$				Units
				$C_L = 15 \text{ pF}$		$C_L = 50 \text{ pF}$		
				Min	Max	Min	Max	
$t_{PLH}$	Propagation Delay Time LOW-to-HIGH Level Output	Select to Output	2		18		27	ns
$t_{PHL}$	Propagation Delay Time HIGH-to-LOW Level Output	Select to Output	2		27		40	ns
$t_{PLH}$	Propagation Delay Time LOW-to-HIGH Level Output	Select to Output	3		18		27	ns
$t_{PHL}$	Propagation Delay Time HIGH-to-LOW Level Output	Select to Output	3		27		40	ns
$t_{PLH}$	Propagation Delay Time LOW-to-HIGH Level Output	Enable to Output	2		18		27	ns
$t_{PHL}$	Propagation Delay Time HIGH-to-LOW Level Output	Enable to Output	2		24		40	ns
$t_{PLH}$	Propagation Delay Time LOW-to-HIGH Level Output	Enable to Output	3		18		27	ns
$t_{PHL}$	Propagation Delay Time HIGH-to-LOW Level Output	Enable to Output	3		28		40	ns

### DM74LS139 Recommended Operating Conditions

Symbol	Parameter	Min	Nom	Max	Units
$V_{CC}$	Supply Voltage	4.75	5	5.25	V
$V_{IH}$	HIGH Level Input Voltage	2			V
$V_{IL}$	LOW Level Input Voltage			0.8	V
$I_{OH}$	HIGH Level Output Current			-0.4	mA
$I_{OL}$	LOW Level Output Current			8	mA
$T_A$	Free Air Operating Temperature	0		70	°C

### DM74LS139 Electrical Characteristics

over recommended operating free air temperature range (unless otherwise noted)

Symbol	Parameter	Conditions	Min	Typ (Note 6)	Max	Units
$V_I$	Input Clamp Voltage	$V_{CC} = \text{Min}, I_I = -18 \text{ mA}$			-1.5	V
$V_{OH}$	HIGH Level Output Voltage	$V_{CC} = \text{Min}, I_{OH} = \text{Max}, V_{IL} = \text{Max}, V_{IH} = \text{Min}$	2.7	3.4		V
$V_{OL}$	LOW Level Output Voltage	$V_{CC} = \text{Min}, I_{OL} = \text{Max}, V_{IL} = \text{Max}, V_{IH} = \text{Min}, I_{OL} = 4 \text{ mA}, V_{CC} = \text{Min}$		0.35 0.25	0.5 0.4	V
$I_I$	Input Current @ Max Input Voltage	$V_{CC} = \text{Max}, V_I = 7\text{V}$			0.1	mA
$I_{IH}$	HIGH Level Input Current	$V_{CC} = \text{Max}, V_I = 2.7\text{V}$			20	$\mu\text{A}$
$I_{IL}$	LOW Level Input Current	$V_{CC} = \text{Max}, V_I = 0.4\text{V}$			-0.36	mA
$I_{OS}$	Short Circuit Output Current	$V_{CC} = \text{Max}$ (Note 7)	-20		-100	mA
$I_{CC}$	Supply Current	$V_{CC} = \text{Max}$ (Note 8)		6.8	11	mA

**Note 6:** All typicals are at  $V_{CC} = 5\text{V}, T_A = 25^\circ\text{C}$ .

**Note 7:** Not more than one output should be shorted at a time, and the duration should not exceed one second.

**Note 8:**  $I_{CC}$  is measured with all outputs enabled and OPEN.

### DM74LS139 Switching Characteristics

at  $V_{CC} = 5\text{V}$  and  $T_A = 25^\circ\text{C}$

Symbol	Parameter	From (Input) To (Output)	$R_L = 2 \text{ k}\Omega$				Units
			$C_L = 15 \text{ pF}$		$C_L = 50 \text{ pF}$		
			Min	Max	Min	Max	
$t_{PLH}$	Propagation Delay Time LOW-to-HIGH Level Output	Select to Output		18		27	ns
$t_{PHL}$	Propagation Delay Time HIGH-to-LOW Level Output	Select to Output		27		40	ns
$t_{PLH}$	Propagation Delay Time LOW-to-HIGH Level Output	Enable to Output		18		27	ns
$t_{PHL}$	Propagation Delay Time HIGH-to-LOW Level Output	Enable to Output		24		40	ns

**Physical Dimensions** inches (millimeters) unless otherwise noted

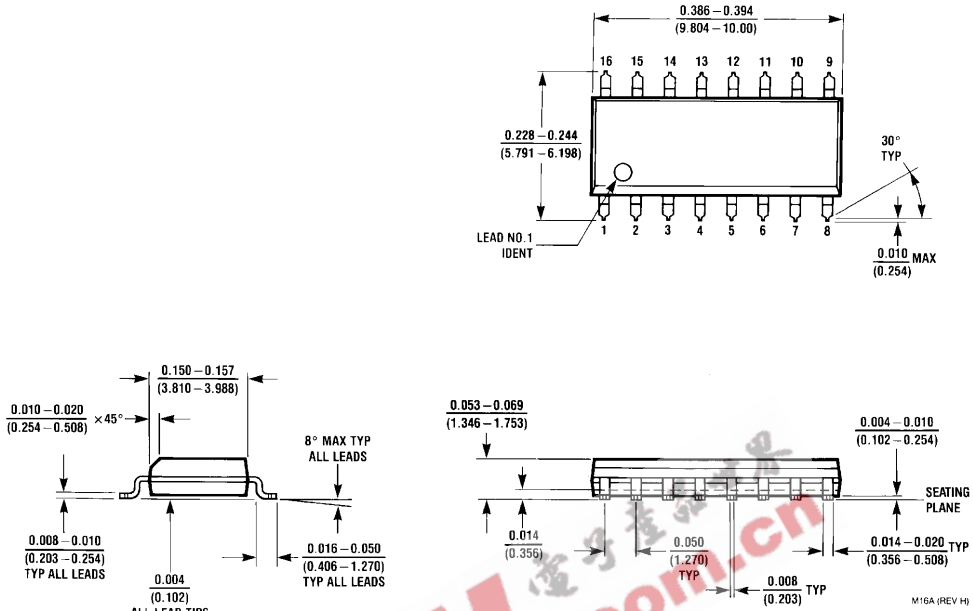

**16-Lead Small Outline Integrated Circuit (SOIC), JEDEC MS-012, 0.150 Narrow**  
**Package Number M16A**

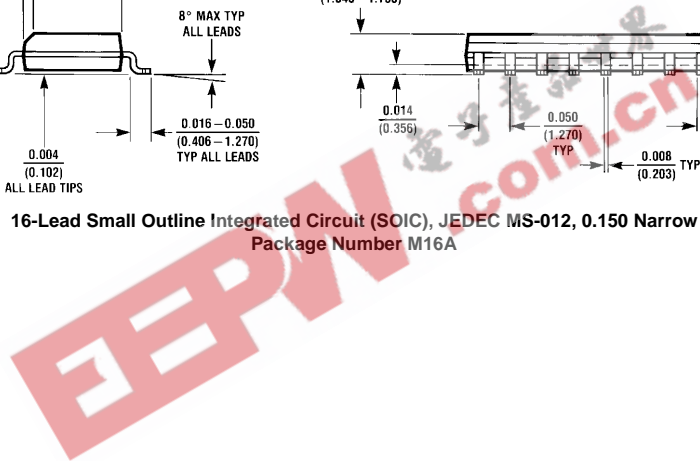

**Physical Dimensions** inches (millimeters) unless otherwise noted (Continued)

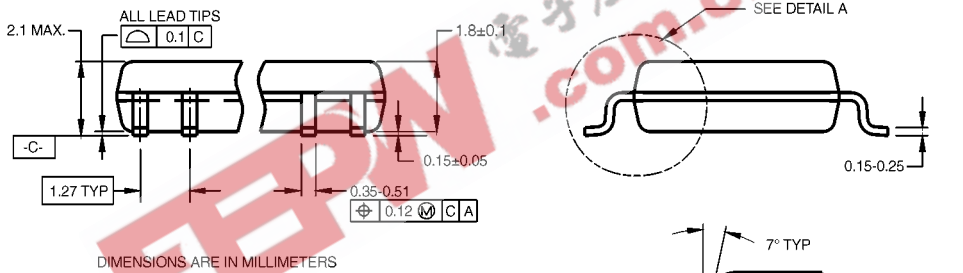
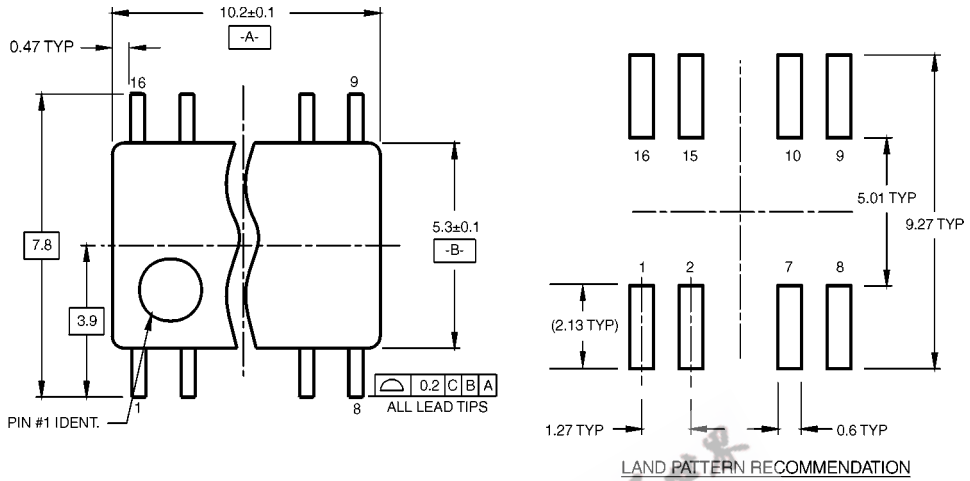

DIMENSIONS ARE IN MILLIMETERS

NOTES:

- A. CONFORMS TO EIAJ EDR-7320 REGISTRATION, ESTABLISHED IN DECEMBER, 1998.
- B. DIMENSIONS ARE IN MILLIMETERS.
- C. DIMENSIONS ARE EXCLUSIVE OF BURRS, MOLD FLASH, AND TIE BAR EXTRUSIONS.

M16DRRevB1

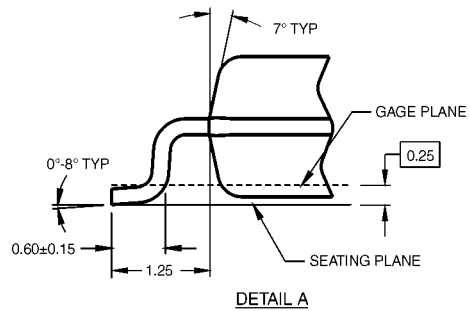

**16-Lead Small Outline Package (SOP), EIAJ TYPE II, 5.3mm Wide Package Number M16D**

**Physical Dimensions** inches (millimeters) unless otherwise noted (Continued)

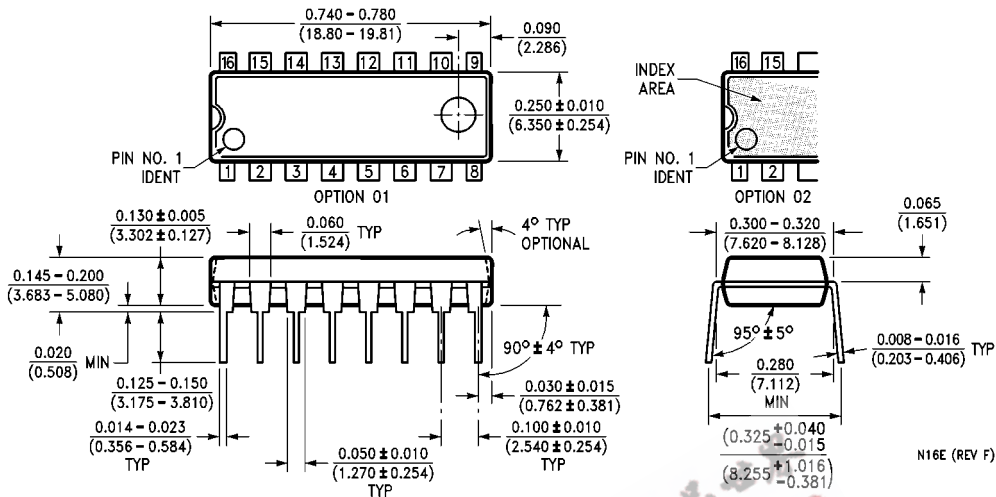

16-Lead Plastic Dual-In-Line Package (PDIP), JEDEC MS-001, 0.300 Wide  
Package Number N16E

Fairchild does not assume any responsibility for use of any circuitry described, no circuit patent licenses are implied and Fairchild reserves the right at any time without notice to change said circuitry and specifications.

**LIFE SUPPORT POLICY**

FAIRCHILD'S PRODUCTS ARE NOT AUTHORIZED FOR USE AS CRITICAL COMPONENTS IN LIFE SUPPORT DEVICES OR SYSTEMS WITHOUT THE EXPRESS WRITTEN APPROVAL OF THE PRESIDENT OF FAIRCHILD SEMICONDUCTOR CORPORATION. As used herein:

1. Life support devices or systems are devices or systems which, (a) are intended for surgical implant into the body, or (b) support or sustain life, and (c) whose failure to perform when properly used in accordance with instructions for use provided in the labeling, can be reasonably expected to result in a significant injury to the user.
2. A critical component in any component of a life support device or system whose failure to perform can be reasonably expected to cause the failure of the life support device or system, or to affect its safety or effectiveness.

[www.fairchildsemi.com](http://www.fairchildsemi.com)