

8-INPUT NOR/OR GATE

- MEDIUM-SPEED OPERATION t_{PHL} , t_{PLH} = 75ns (TYP.) AT V_{DD} = 10V
- QUIESCENT CURRENT SPECIFIED TO 20V FOR HCC DEVICE
- 5V, 10V, AND 15V PARAMETRIC RATINGS
- INPUT CURRENT OF 100nA AT 18V AND 25°C FOR HCC DEVICE
- 100% TESTED FOR QUIESCENT CURRENT
- MEETS ALL REQUIREMENTS OF JEDEC TENTATIVE STANDARD No. 13A, "STANDARD SPECIFICATIONS FOR DESCRIPTION OF "B" SERIES CMOS DEVICES"

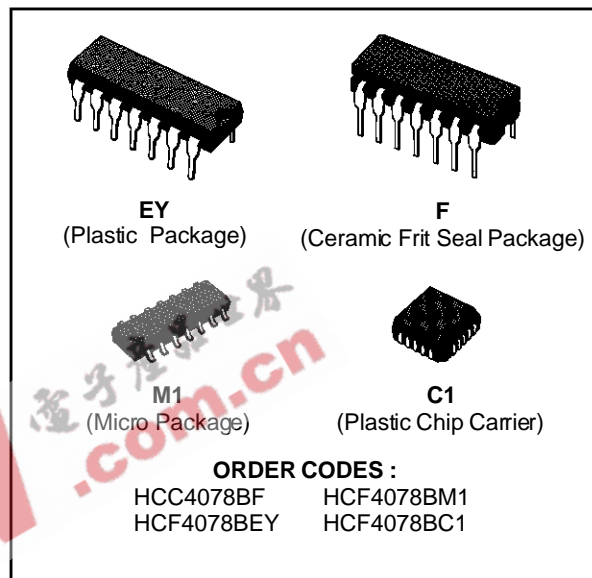

EEPW.com.cn

DESCRIPTION

The **HCC4078B** (extended temperature range) and **HCF4078B** (intermediate temperature range) are monolithic integrated circuit, available in 14-lead dual in-line plastic or ceramic package, plastic micropackage.

The **HCC/HCF4078B** NOR/OR Gate provides the system designer with direct implementation of the positive-logic-8-input NOR and OR function and supplements the existing family of COS/MOS gates.

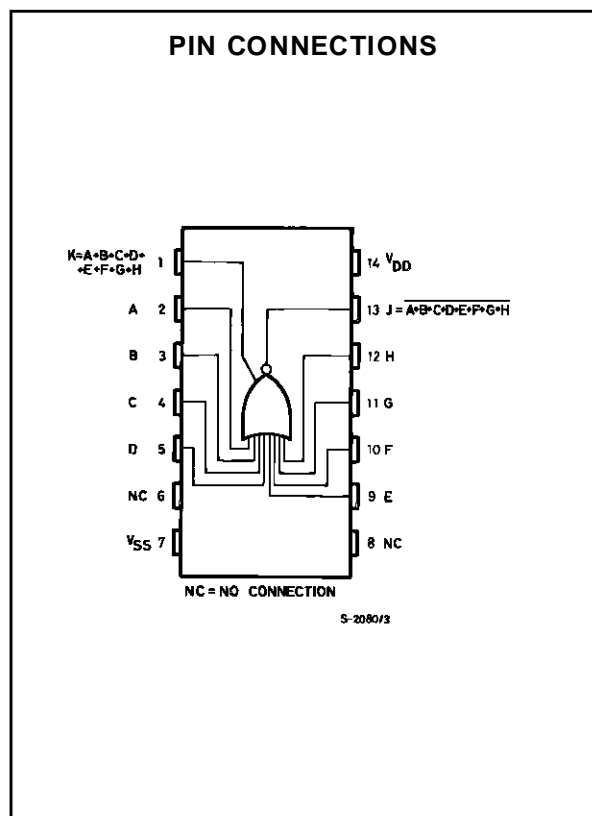

HCC/HCF4078B

ABSOLUTE MAXIMUM RATINGS

| Symbol | Parameter | Value | Unit |
|-------------------|---|--------------------------------|------|
| V _{DD} * | Supply Voltage : HCC Types | - 0.5 to + 20 | V |
| | HCF Types | - 0.5 to + 18 | V |
| V _i | Input Voltage | - 0.5 to V _{DD} + 0.5 | V |
| I _I | DC Input Current (any one input) | ± 10 | mA |
| P _{tot} | Total Power Dissipation (per package) | 200 | mW |
| | Dissipation per Output Transistor for T _{op} = Full Package-temperature Range | 100 | mW |
| T _{op} | Operating Temperature : HCC Types | - 55 to + 125 | °C |
| | HCF Types | - 40 to + 85 | °C |
| T _{stg} | Storage Temperature | - 65 to + 150 | °C |

Stresses above those listed under "Absolute Maximum Ratings" may cause permanent damage to the device. This is a stress rating only and functional operation of the device at these or any other conditions above those indicated in the operational sections of this specification is not implied. Exposure to absolute maximum rating conditions for external periods may affect device reliability.

* All voltage values are referred to V_{SS} pin voltage.

RECOMMENDED OPERATING CONDITIONS

| Symbol | Parameter | Value | Unit |
|-----------------|--|----------------------|------|
| V _{DD} | Supply Voltage : HCC Types | 3 to 18 | V |
| | HCF Types | 3 to 15 | V |
| V _I | Input Voltage | 0 to V _{DD} | V |
| T _{op} | Operating Temperature : HCC Types | - 55 to + 125 | °C |
| | HCF Types | - 40 to + 85 | °C |

STATIC ELECTRICAL CHARACTERISTICS (over recommended operating conditions)

| Symbol | Parameter | Test Conditions | | | | Value | | | | | | Unit | | |
|-----------------------------------|-----------------------|-----------------------|-----------------------|--------------------------------|------------------------|--------------------|-----------|-------|---------------|-----------|---------------------|---------|---------|---------|
| | | V _I (V) | V _O (V) | I _O (μ A) | V _{DD} (V) | T _{Low} * | | 25°C | | | T _{High} * | | | |
| | | | | | | Min. | Max. | Min. | Typ. | Max. | Min. | | Max. | |
| I _L | Quiescent Current | HCC Types | 0/ 5 | | | 5 | | 0.25 | | 0.01 | 0.25 | | 7.5 | μ A |
| | | | 0/10 | | | 10 | | 0.5 | | 0.01 | 0.5 | | 15 | |
| | | | 0/15 | | | 15 | | 1 | | 0.01 | 1 | | 30 | |
| | | HCF Types | 0/ 5 | | | 5 | | 1 | | 0.01 | 1 | | 7.5 | |
| | | | 0/10 | | | 10 | | 2 | | 0.01 | 2 | | 15 | |
| | | | 0/15 | | | 15 | | 4 | | 0.01 | 4 | | 30 | |
| V _{OH} | Output High Voltage | 0/ 5 | | < 1 | 5 | 4.95 | | 4.95 | | | 4.95 | | V | |
| | | 0/10 | | < 1 | 10 | 9.95 | | 9.95 | | | 9.95 | | | |
| | | 0/15 | | < 1 | 15 | 14.95 | | 14.95 | | | 14.95 | | | |
| V _{OL} | Output Low Voltage | 5/0 | | < 1 | 5 | | 0.05 | | | 0.05 | | 0.05 | V | |
| | | 10/0 | | < 1 | 10 | | 0.05 | | | 0.05 | | 0.05 | | |
| | | 15/0 | | < 1 | 15 | | 0.05 | | | 0.05 | | 0.05 | | |
| V _{IH} | Input High Voltage | | 0.5/4.5 | < 1 | 5 | 3.5 | | 3.5 | | | 3.5 | | V | |
| | | | 1/9 | < 1 | 10 | 7 | | 7 | | | 7 | | | |
| | | | 1.5/13.5 | < 1 | 15 | 11 | | 11 | | | 11 | | | |
| V _{IL} | Input Low Voltage | | 4.5/0.5 | < 1 | 5 | | 1.5 | | | 1.5 | | 1.5 | V | |
| | | | 9/1 | < 1 | 10 | | 3 | | | 3 | | 3 | | |
| | | | 13.5/1.5 | < 1 | 15 | | 4 | | | 4 | | 4 | | |
| I _{OH} | Output Drive Current | HCC Types | 0/ 5 | 2.5 | | 5 | - 2 | | - 1.6 | - 3.2 | | - 1.15 | mA | |
| | | | 0/ 5 | 4.6 | | 5 | - 0.64 | | - 0.51 | - 1 | | - 0.36 | | |
| | | | 0/10 | 9.5 | | 10 | - 1.6 | | - 1.3 | - 2.6 | | - 0.9 | | |
| | | HCF Types | 0/15 | 13.5 | | 15 | - 4.2 | | - 3.4 | - 6.8 | | - 2.4 | | |
| | | | 0/ 5 | 2.5 | | 5 | - 1.53 | | - 1.36 | - 3.2 | | - 1.1 | | |
| | | | 0/ 5 | 4.6 | | 5 | - 0.52 | | - 0.44 | - 1 | | - 0.36 | | |
| HCF Types | 0/10 | 9.5 | | 10 | - 1.3 | | - 1.1 | - 2.6 | | - 0.9 | | | | |
| | 0/15 | 13.5 | | 15 | - 3.6 | | - 3.0 | - 6.8 | | - 2.4 | | | | |
| | I _{OL} | Output Sink Current | HCC Types | 0/ 5 | 0.4 | | 5 | 0.64 | | 0.51 | 1 | | 0.36 | mA |
| 0/10 | | | | 0.5 | | 10 | 1.6 | | 1.3 | 2.6 | | 0.9 | | |
| 0/15 | | | | 1.5 | | 15 | 4.2 | | 3.4 | 6.8 | | 2.4 | | |
| HCF Types | | | 0/ 5 | 0.4 | | 5 | 0.52 | | 0.44 | 1 | | 0.36 | | |
| | | | 0/10 | 0.5 | | 10 | 1.3 | | 1.1 | 2.6 | | 0.9 | | |
| | | | 0/15 | 1.5 | | 15 | 3.6 | | 3.0 | 6.8 | | 2.4 | | |
| I _{IH} , I _{IL} | Input Leakage Current | HCC Types | 0/18 | Any Input | 18 | | \pm 0.1 | | $\pm 10^{-5}$ | \pm 0.1 | | \pm 1 | μ A | |
| | | HCF Types | 0/15 | | 15 | | \pm 0.3 | | $\pm 10^{-5}$ | \pm 0.3 | | \pm 1 | | |
| C _I | Input Capacitance | | | Any Input | | | | | 5 | 7.5 | | | pF | |

* T_{Low} = - 55°C for HCC device : - 40°C for HCF device.* T_{High} = + 125°C for HCC device : + 85°C for HCF device.The Noise Margin for both "1" and "0" level is : 1V min. with V_{DD} = 5V, 2V min. with V_{DD} = 10V, 2.5 V min. with V_{DD} = 15V.

HCC/HCF4078B

DYNAMIC ELECTRICAL CHARACTERISTICS ($T_{amb} = 25^{\circ}\text{C}$, $C_L = 50\text{pF}$, $R_L = 200\text{k}\Omega$, typical temperature coefficient for all V_{DD} values is $0.3\%/^{\circ}\text{C}$, all input rise and fall time = 20ns)

| Symbol | Parameter | Test Conditions | | Value | | | Unit |
|-----------------------|------------------------|-----------------|--------------|-------|------|------|------|
| | | | V_{DD} (V) | Min. | Typ. | Max. | |
| t_{PHL} , t_{PLH} | Propagation Delay Time | | 5 | | 150 | 300 | ns |
| | | | 10 | | 75 | 150 | |
| | | | 15 | | 55 | 110 | |
| t_{THL} , t_{TLH} | Transition Time | | 5 | | 100 | 200 | ns |
| | | | 10 | | 50 | 100 | |
| | | | 15 | | 40 | 80 | |

Typical Output Low (sink) Current Characteristics.

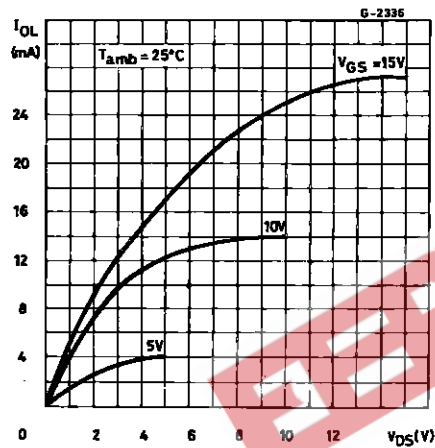

Minimum Output Low (sink) Current Characteristics.

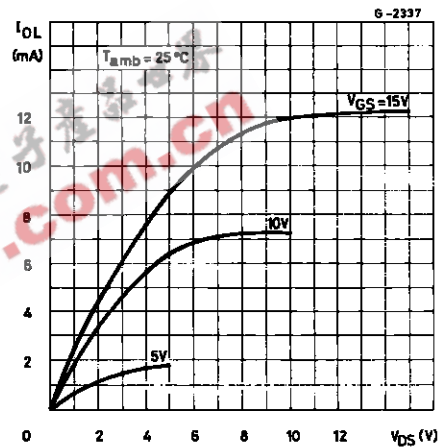

Typical Output High (source) Current Characteristics.

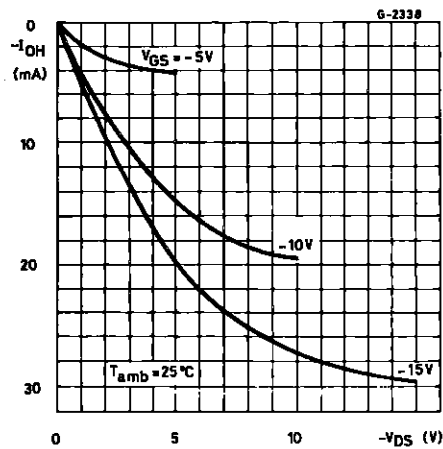

Minimum Output High (source) Current Characteristics.

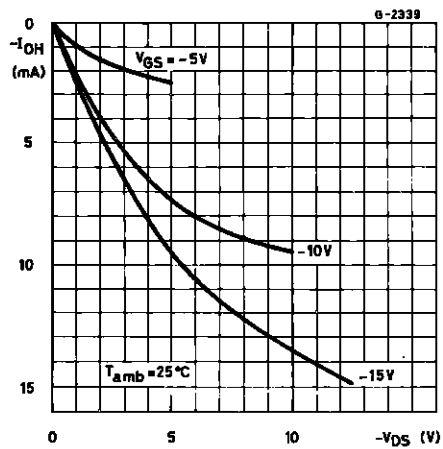

Typical Voltage Transfer Characteristics (NOR output).

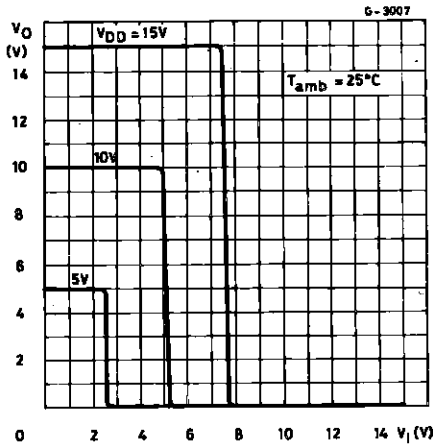

Typical Transition Time vs. Load Capacitance.

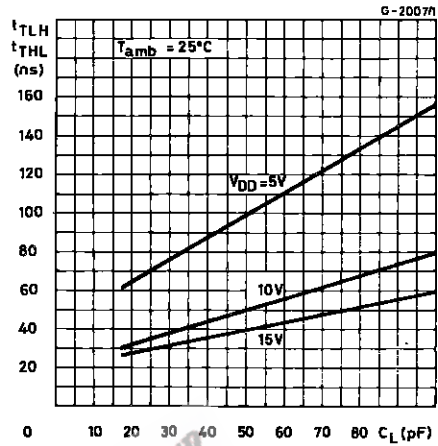

Typical Propagation Delay Time vs. Load Capacitance.

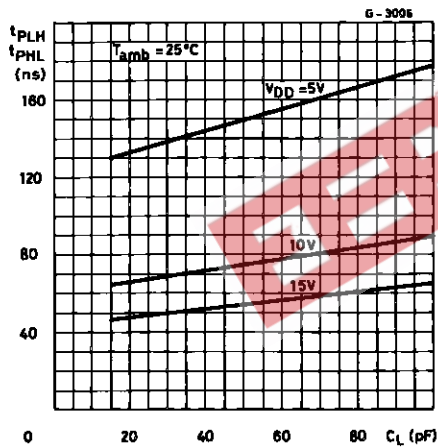

Typical Power Dissipation vs. Frequency.

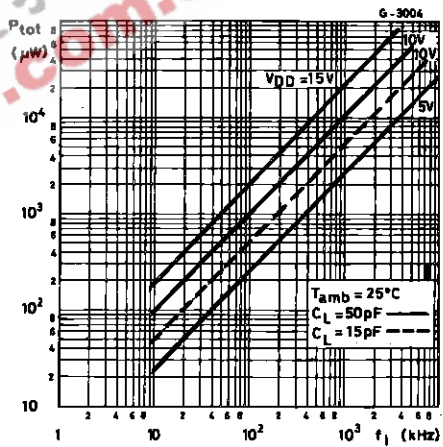

HCC/HCF4078B

TEST CIRCUITS

Quiescent Device Current.

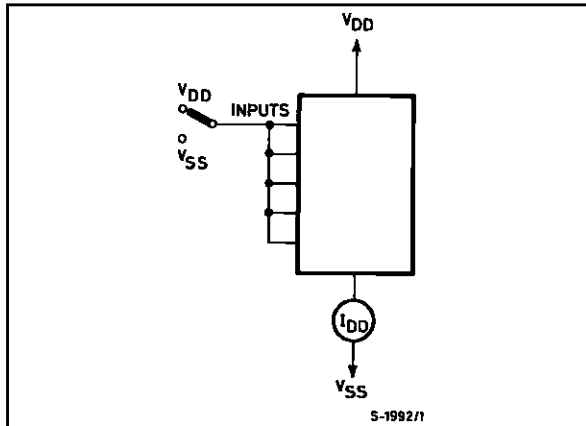

Input Voltage.

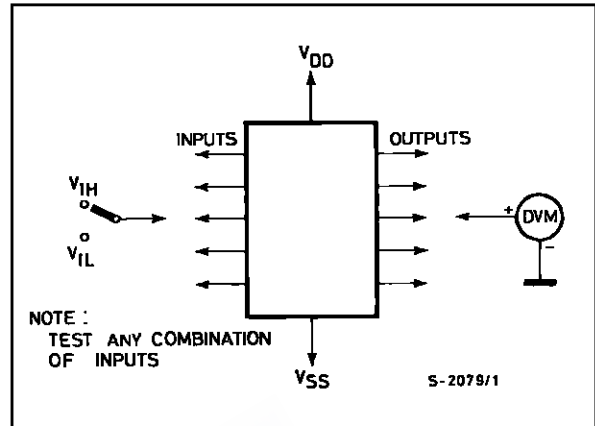

Input Current.

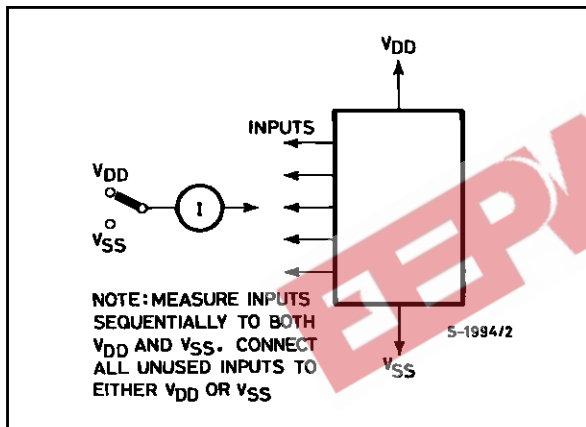

Dynamic Power Dissipation.

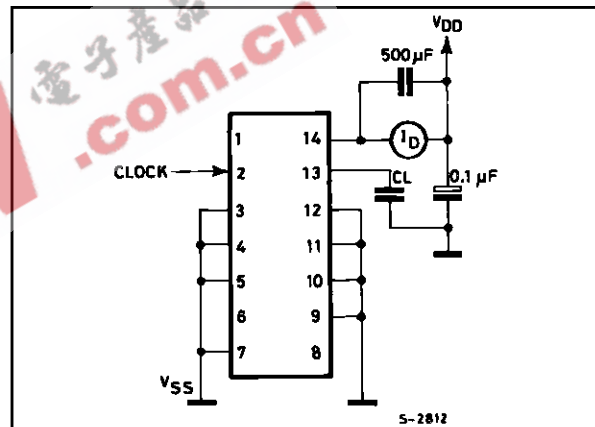

Plastic DIP14 MECHANICAL DATA

| DIM. | mm | | | inch | | |
|------|------|-------|------|-------|-------|-------|
| | MIN. | TYP. | MAX. | MIN. | TYP. | MAX. |
| a1 | 0.51 | | | 0.020 | | |
| B | 1.39 | | 1.65 | 0.055 | | 0.065 |
| b | | 0.5 | | | 0.020 | |
| b1 | | 0.25 | | | 0.010 | |
| D | | | 20 | | | 0.787 |
| E | | 8.5 | | | 0.335 | |
| e | | 2.54 | | | 0.100 | |
| e3 | | 15.24 | | | 0.600 | |
| F | | | 7.1 | | | 0.280 |
| I | | | 5.1 | | | 0.201 |
| L | | 3.3 | | | 0.130 | |
| Z | 1.27 | | 2.54 | 0.050 | | 0.100 |

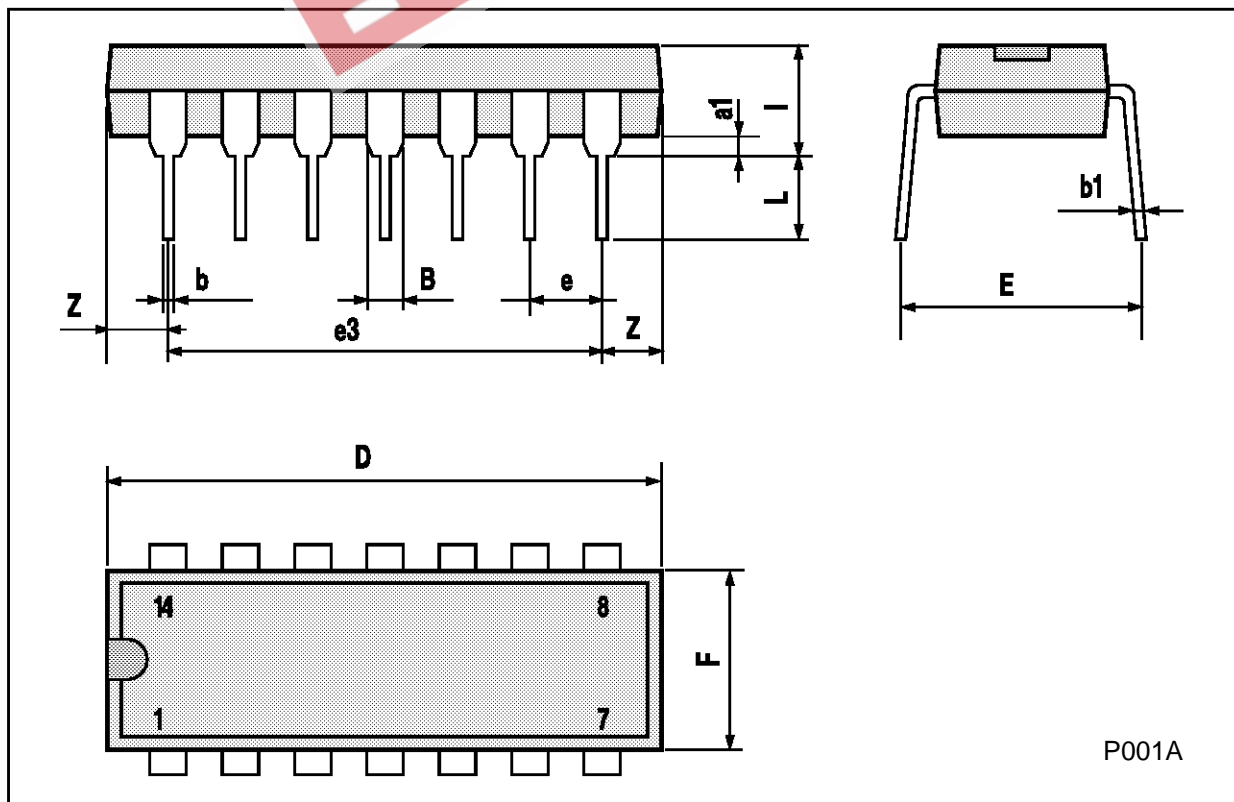

HCC/HCF4078B

Ceramic DIP14/1 MECHANICAL DATA

| DIM. | mm | | | inch | | |
|------|------|-------|------|-------|-------|-------|
| | MIN. | TYP. | MAX. | MIN. | TYP. | MAX. |
| A | | | 20 | | | 0.787 |
| B | | | 7.0 | | | 0.276 |
| D | | 3.3 | | | 0.130 | |
| E | 0.38 | | | 0.015 | | |
| e3 | | 15.24 | | | 0.600 | |
| F | 2.29 | | 2.79 | 0.090 | | 0.110 |
| G | 0.4 | | 0.55 | 0.016 | | 0.022 |
| H | 1.17 | | 1.52 | 0.046 | | 0.060 |
| L | 0.22 | | 0.31 | 0.009 | | 0.012 |
| M | 1.52 | | 2.54 | 0.060 | | 0.100 |
| N | | | 10.3 | | | 0.406 |
| P | 7.8 | | 8.05 | 0.307 | | 0.317 |
| Q | | | 5.08 | | | 0.200 |

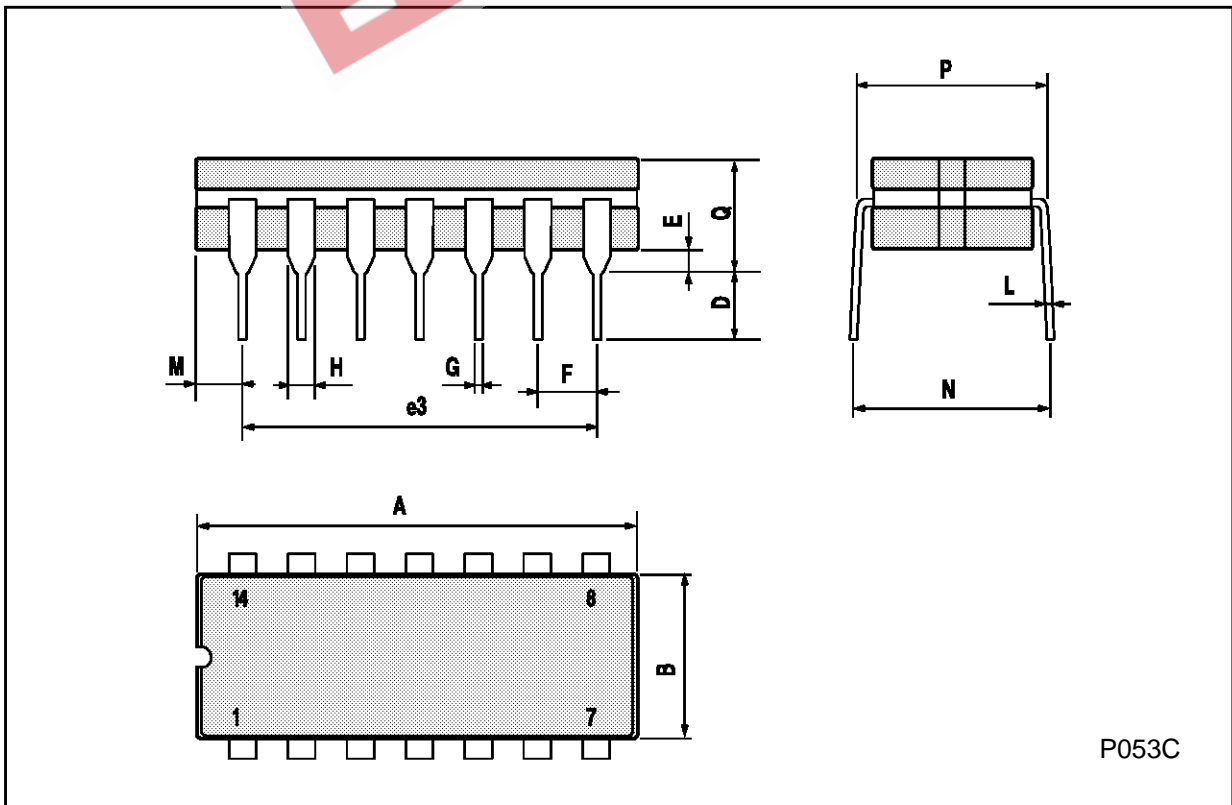

SO14 MECHANICAL DATA

| DIM. | mm | | | inch | | |
|------|------------|------|------|-------|-------|-------|
| | MIN. | TYP. | MAX. | MIN. | TYP. | MAX. |
| A | | | 1.75 | | | 0.068 |
| a1 | 0.1 | | 0.2 | 0.003 | | 0.007 |
| a2 | | | 1.65 | | | 0.064 |
| b | 0.35 | | 0.46 | 0.013 | | 0.018 |
| b1 | 0.19 | | 0.25 | 0.007 | | 0.010 |
| C | | 0.5 | | | 0.019 | |
| c1 | 45° (typ.) | | | | | |
| D | 8.55 | | 8.75 | 0.336 | | 0.344 |
| E | 5.8 | | 6.2 | 0.228 | | 0.244 |
| e | | 1.27 | | | 0.050 | |
| e3 | | 7.62 | | | 0.300 | |
| F | 3.8 | | 4.0 | 0.149 | | 0.157 |
| G | 4.6 | | 5.3 | 0.181 | | 0.208 |
| L | 0.5 | | 1.27 | 0.019 | | 0.050 |
| M | | | 0.68 | | | 0.026 |
| S | 8° (max.) | | | | | |

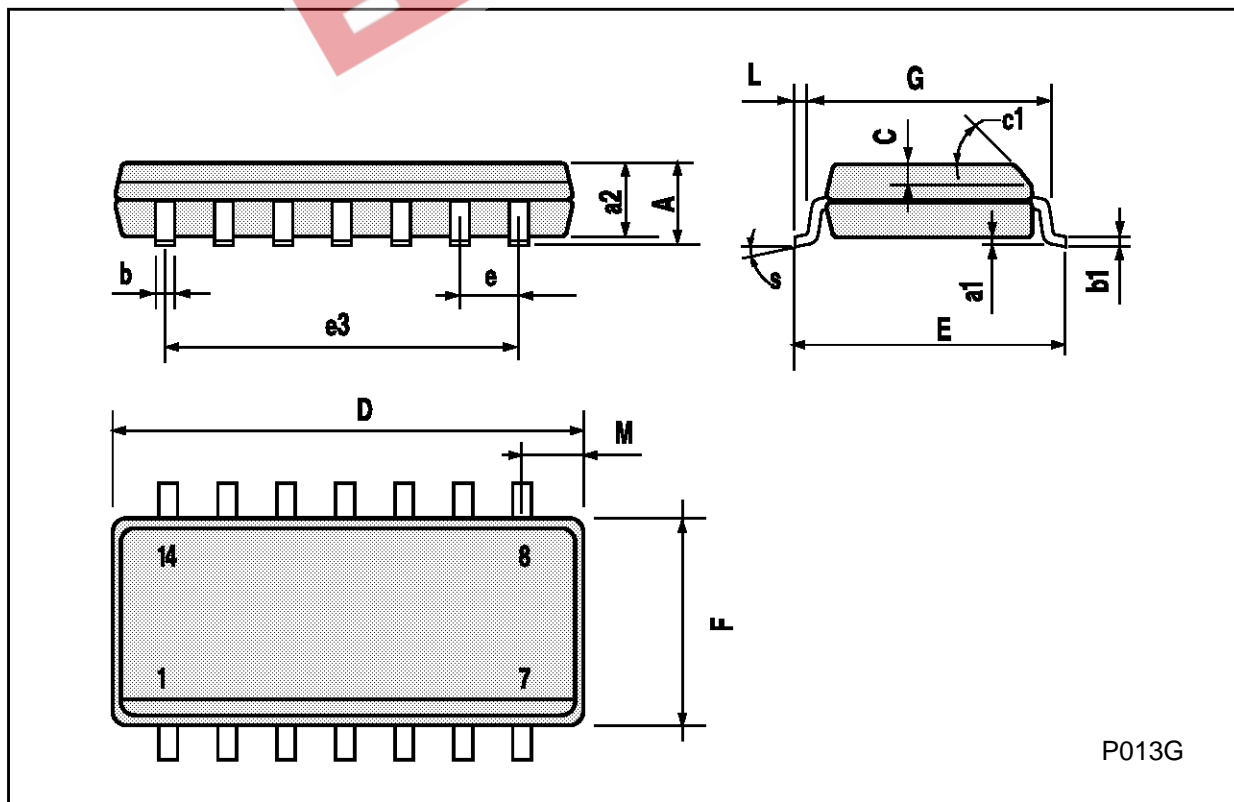

PLCC20 MECHANICAL DATA

| DIM. | mm | | | inch | | |
|------|------|------|-------|-------|-------|-------|
| | MIN. | TYP. | MAX. | MIN. | TYP. | MAX. |
| A | 9.78 | | 10.03 | 0.385 | | 0.395 |
| B | 8.89 | | 9.04 | 0.350 | | 0.356 |
| D | 4.2 | | 4.57 | 0.165 | | 0.180 |
| d1 | | 2.54 | | | 0.100 | |
| d2 | | 0.56 | | | 0.022 | |
| E | 7.37 | | 8.38 | 0.290 | | 0.330 |
| e | | 1.27 | | | 0.050 | |
| e3 | | 5.08 | | | 0.200 | |
| F | | 0.38 | | | 0.015 | |
| G | | | 0.101 | | | 0.004 |
| M | | 1.27 | | | 0.050 | |
| M1 | | 1.14 | | | 0.045 | |

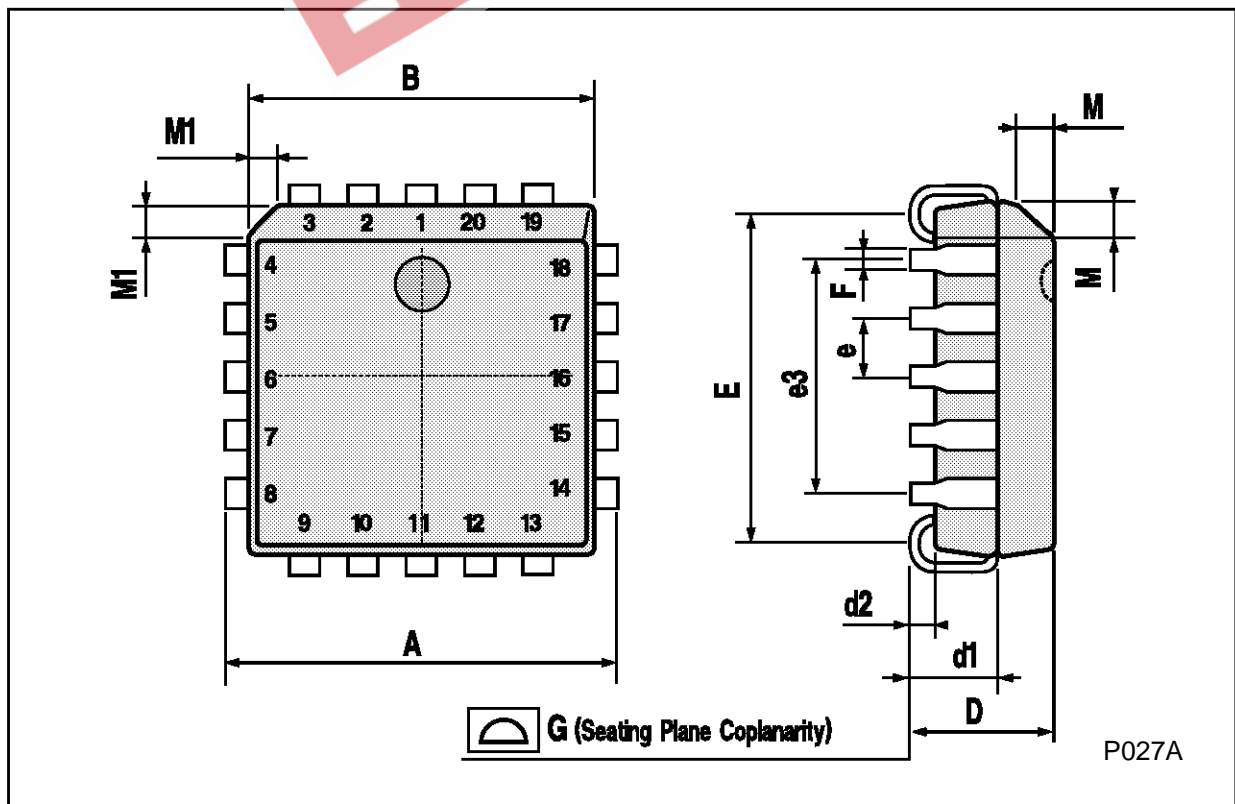

EEPW 电子產品世界
.com.cn

Information furnished is believed to be accurate and reliable. However, SGS-THOMSON Microelectronics assumes no responsibility for the consequences of use of such information nor for any infringement of patents or other rights of third parties which may result from its use. No license is granted by implication or otherwise under any patent or patent rights of SGS-THOMSON Microelectronics. Specifications mentioned in this publication are subject to change without notice. This publication supersedes and replaces all information previously supplied. SGS-THOMSON Microelectronics products are not authorized for use as critical components in life support devices or systems without express written approval of SGS-THOMSON Microelectronics.

© 1994 SGS-THOMSON Microelectronics - All Rights Reserved

SGS-THOMSON Microelectronics GROUP OF COMPANIES

Australia - Brazil - France - Germany - Hong Kong - Italy - Japan - Korea - Malaysia - Malta - Morocco - The Netherlands -
Singapore - Spain - Sweden - Switzerland - Taiwan - Thailand - United Kingdom - U.S.A