

FST3245 — 8-Bit Bus Switch

Features

- 4Ω Switch Connection between Two Ports
- Minimal Propagation Delay through the Switch
- Low I_{cc}
- Zero Bounce in Flow-through Mode
- Control Inputs Compatible with TTL Level

Description

The FST3245 switch provides eight-bits of high-speed CMOS TTL-compatible bus switching in a standard '245 pin-out. The low on resistance allows inputs to be connected to outputs without adding propagation delay or generating additional ground bounce noise.

The device is organized as an eight-bit switch. When /OE is LOW, the switch is ON and port A is connected to port B. When /OE is HIGH, the switch is OPEN and a high-impedance state exists between the two ports.

Ordering Information

Part Number	Operating Temperature Range	Package	Packing Method
FST3245WMX	-40 to +85°C	20-Lead, Small Outline Integrated Circuit (SOIC), JEDEC MS-013, 0.300-inch Wide	Tape and Reel
FST3245QSC	-40 to +85°C	20-Lead Quarter Size Outline Package (QSOP), JEDEC MO-137, 0.150-inch Wide	Tube
FST3245QSCX	-40 to +85°C	20-Lead Quarter Size Outline Package (QSOP), JEDEC MO-137, 0.150-inch Wide	Tape and Reel
FST3245MTC	-40 to +85°C	20-Lead Thin Shrink Small Outline Package (TSSOP), JEDEC MO-153, 4.4mm Wide	Tube
FST3245MTCX	-40 to +85°C	20-Lead Thin Shrink Small Outline Package (TSSOP), JEDEC MO-153, 4.4mm Wide	Tape and Reel

Ⓢ All packages are lead free per JEDEC: J-STD-020B standard.

The Fairchild switch family derives from and embodies Fairchild's proven switch technology used for several years in its 74LVX3L384 (FST3384) bus switch product.

Logic Diagram

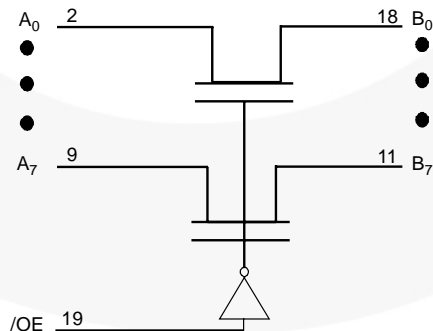

Figure 1. Logic Diagram

Pin Configuration

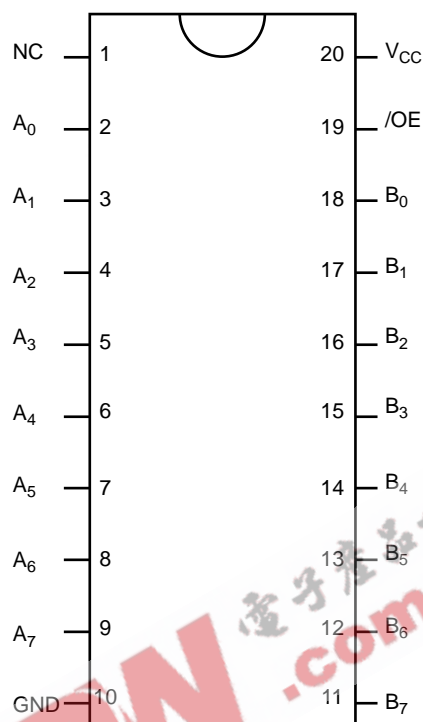

Figure 2. Pin Configuration

Pin Descriptions

Pin #	Pin Names	Description
1	NC	No Connect
19	/OE	Bus Switch Enable
2,3,4,5,6,7,8,9	A ₀ ,A ₁ ,A ₂ ,A ₃ ,A ₄ ,A ₅ ,A ₆ ,A ₇	Bus A
10	GND	Ground
11,12,13,14,15,16,17,18	B ₇ ,B ₆ ,B ₅ ,B ₄ ,B ₃ ,B ₂ ,B ₁ ,B ₀	Bus B
20	V _{CC}	Supply Voltage

Truth Table

Input /OE	Function
LOW	Connect
HIGH	Disconnect

Absolute Maximum Ratings

Stresses exceeding the absolute maximum ratings may damage the device. The device may not function or be operable above the recommended operating conditions and stressing the parts to these levels is not recommended. In addition, extended exposure to stresses above the recommended operating conditions may affect device reliability. The absolute maximum ratings are stress ratings only.

Symbol	Parameter	Min.	Max.	Unit
V _{CC}	Supply Voltage	-0.5	7.0	V
V _S	DC Switch Voltage	-0.5	7.0	V
V _{IN}	DC Input Voltage ⁽¹⁾	-0.5	7.0	V
I _{IK}	DC Input Diode Current, V _{IN} < 0V		-50	mA
I _{OUT}	DC Output Sink Current		128	mA
I _{CC} / I _{GND}	DC V _{CC} / GND Current		±100	mA
T _{STG}	Storage Temperature Range	-65	+150	°C

Note:

- The input and output negative voltage ratings may be exceeded if the input and output diode current ratings are observed.

Recommended Operating Conditions

The Recommended Operating Conditions table defines the conditions for actual device operation. Recommended operating conditions are specified to ensure optimal performance to the datasheet specifications. Fairchild does not recommend exceeding them or designing to Absolute Maximum Ratings.

Symbol	Parameter	Min.	Max.	Unit	
V _{CC}	Power Supply Operating	4.0	5.5	V	
V _{IN}	Input Voltage	0	5.5	V	
V _{OUT}	Output Voltage	0	5.5	V	
t _r , t _f	Input Rise and Fall Time	Switch Control Input ⁽²⁾	0	5	ns/V
		Switch I/O	0	DC	
T _A	Operating Temperature, Free Air	-40	+85	°C	

Note:

- Unused control inputs must be held HIGH or LOW. They may not float.

DC Electrical Characteristics

Typical values are at $V_{CC} = 5.0V$ and $T_A = 25^\circ C$.

Symbol	Parameter	Conditions	V_{CC} (V)	$T_A = -40$ to $+85^\circ C$			Units
				Min.	Typ.	Max.	
V_{IK}	Clamp Diode Voltage	$I_{IN} = -18mA$	4.5			-1.2	V
V_{IH}	High-Level Input Voltage		4.0 to 5.5	2.0			V
V_{IL}	Low-Level Input Voltage		4.0 to 5.5			0.8	V
I_{IN}	Input Leakage Current	$0 \leq V_{IN} \leq 5.5V$	5.5			± 1.0	μA
I_{OZ}	Off-state Leakage Current	$0 \leq A, B \leq V_{CC}$	5.5			± 1.0	μA
R_{ON}	Switch On Resistance ⁽³⁾	$V_{IN} = 0V, I_{IN} = 64mA$	4.5		4	7	Ω
		$V_{IN} = 0V, I_{IN} = 30mA$	4.5		4	7	
		$V_{IN} = 2.4V, I_{IN} = 15mA$	4.5		8	15	
		$V_{IN} = 2.4V, I_{IN} = 15mA$	4.0		11	20	
I_{CC}	Quiescent Supply Current	$V_{IN} = V_{CC}$ or GND, $I_{OUT} = 0$	5.5			3	μA
ΔI_{CC}	Increase in I_{CC} per Input	One Input at 3.4V, Other Inputs at V_{CC} or GND	5.5			2.5	mA

Note:

3. Measured by the voltage drop between the A and B pins at the indicated current through the switch. On resistance is determined by the lower of the voltages on the A or B pins.

AC Electrical Characteristics

$T_A = -40$ to $+85^\circ C$, $C_L = 50pF$, and $R_U = R_D = 500\Omega$.

Symbol	Parameter	Conditions	$V_{CC} = 4.5 - 5.5V$		$V_{CC} = 4.0V$		Units	Figure
			Min.	Max.	Min.	Max.		
t_{PHL}, t_{PLH}	Propagation Delay Bus-to-Bus ⁽⁴⁾	$V_{IN} = \text{Open}$		0.25		0.25	ns	Figure 3 Figure 4
t_{PZH}, t_{PZL}	Output Enable Time	$V_{IN} = 7V$ for t_{PZL} $V_{IN} = \text{Open}$ for t_{PZH}	1.5	5.9		6.4	ns	Figure 3 Figure 4
t_{PHZ}, t_{PLZ}	Output Disable Time	$V_{IN} = 7V$ for t_{PLZ} $V_{IN} = \text{Open}$ for t_{PHZ}	1.5	6.0		5.7	ns	Figure 3 Figure 4

Note:

4. This parameter is guaranteed by design, but is not tested. The bus switch contributes no propagation delay other than the RC delay of the typical on resistance of the switch and the 50pF load capacitance when driven by an ideal voltage source (zero output impedance).

Capacitance

$T_A = +25^\circ C$, $f = 1MHz$. Capacitance is characterized, but not tested.

Symbol	Parameter	Conditions	Typ.	Units
C_{IN}	Control Pin Input Capacitance	$V_{CC} = 5.0V$	3	pF
$C_{I/O}$	Input/Output Capacitance	$V_{CC}, /OE = 5.0V$	5	pF

AC Loadings and Waveforms

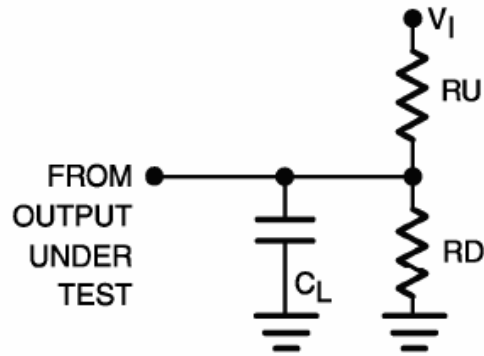

Notes: Input driven by 50Ω source terminated in 50Ω .
 C_L includes load and stray capacitance.
 Input PRR = 1.0MHz, $t_w = 500ns$.

Figure 3. AC Test Circuit

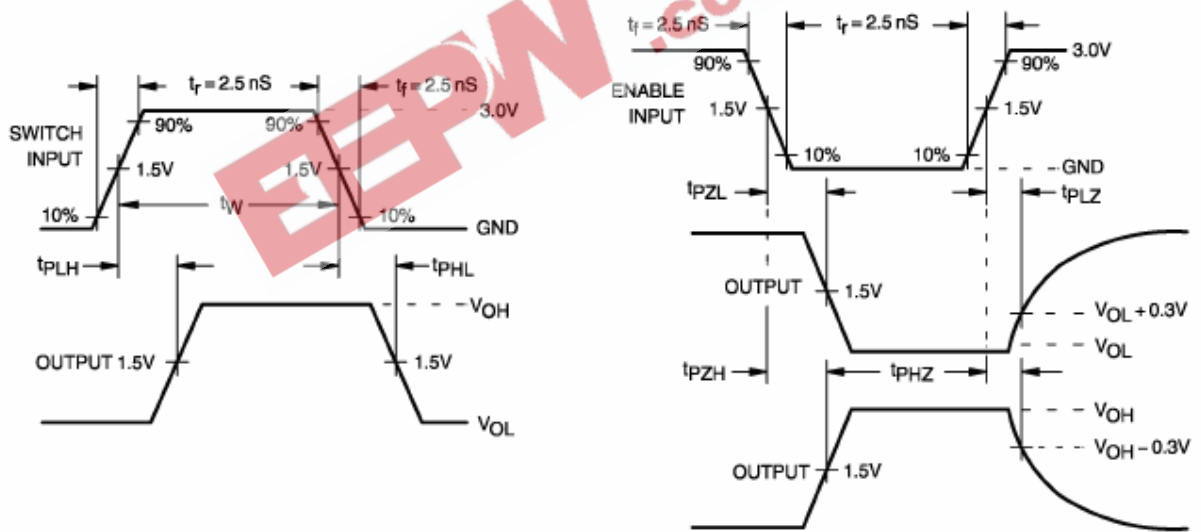

Figure 4. AC Waveforms



Physical Dimensions

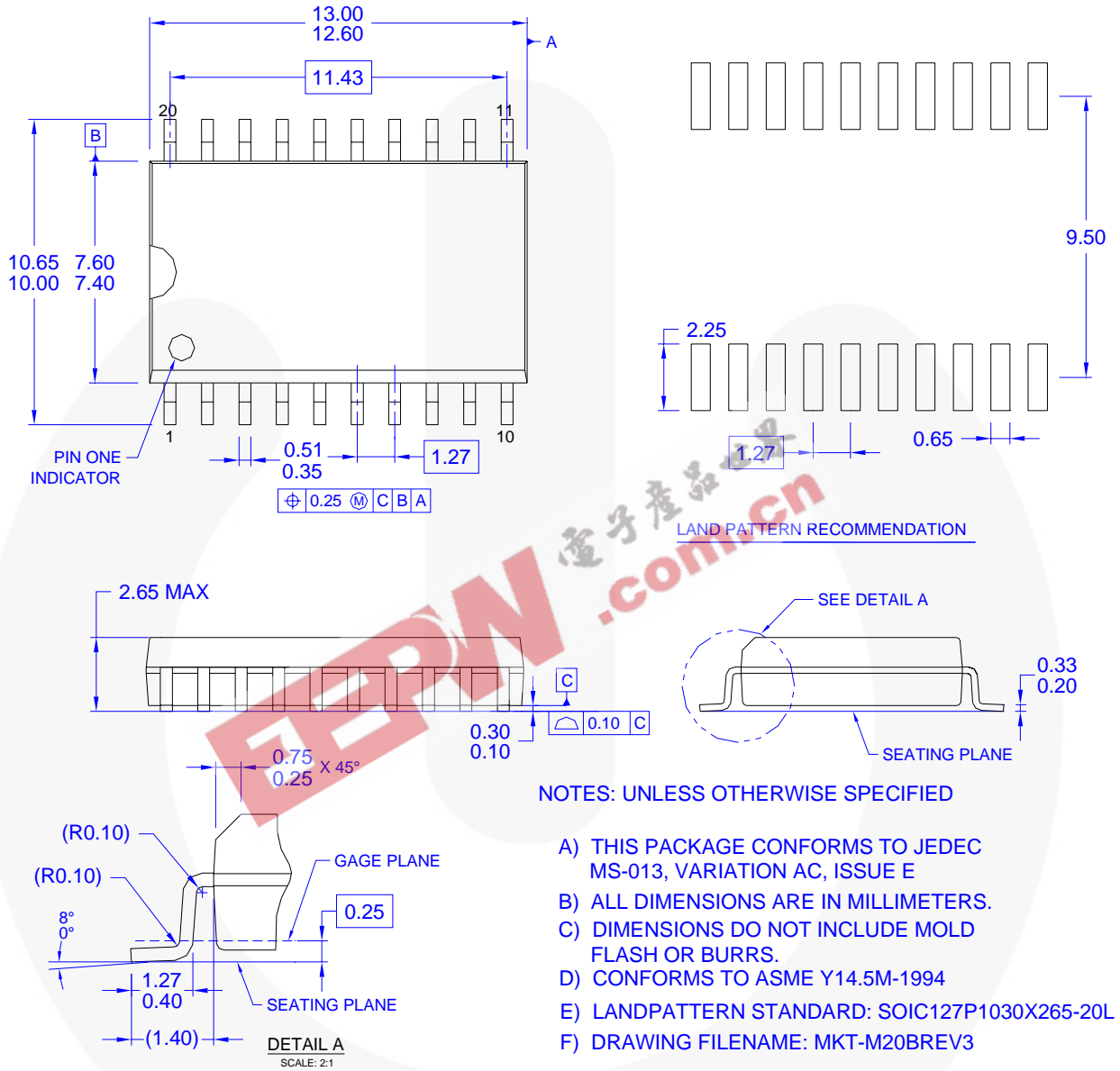
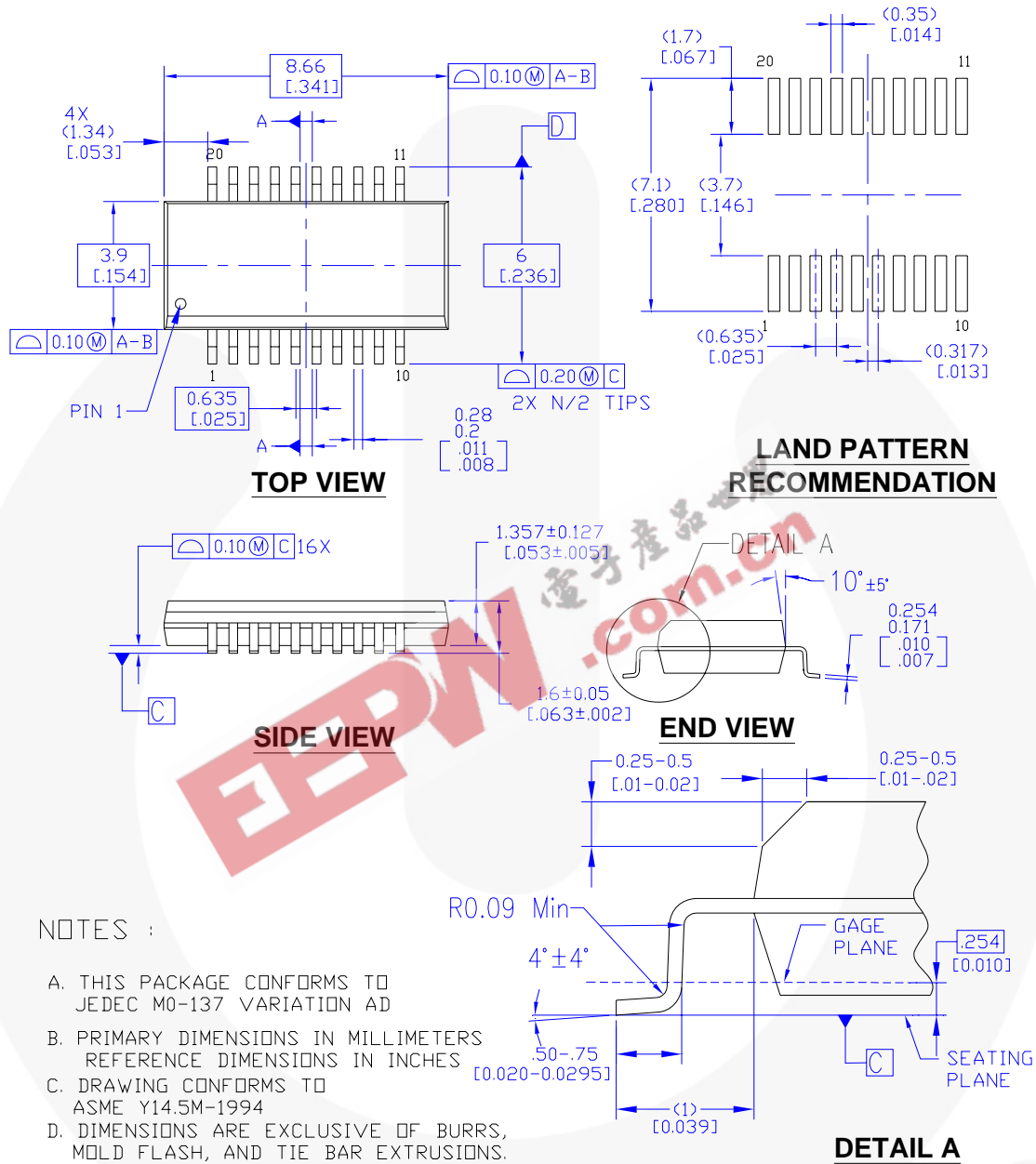

Figure 5. 20-Lead, Small Outline Integrated Circuit (SOIC), JEDEC MS-013, 0.300-inch Wide

Package drawings are provided as a service to customers considering Fairchild components. Drawings may change in any manner without notice. Please note the revision and/or date on the drawing and contact a Fairchild Semiconductor representative to verify or obtain the most recent revision. Package specifications do not expand the terms of Fairchild's worldwide terms and conditions, specifically the warranty therein, which covers Fairchild products.

Always visit Fairchild Semiconductor's online packaging area for the most recent package drawings:
<http://www.fairchildsemi.com/packaging/>

Physical Dimensions



MQA20REVA

Figure 6. 20-Lead Quarter Size Outline Package (QSOP), JEDEC MO-137, 0.150-inch Wide

Package drawings are provided as a service to customers considering Fairchild components. Drawings may change in any manner without notice. Please note the revision and/or date on the drawing and contact a Fairchild Semiconductor representative to verify or obtain the most recent revision. Package specifications do not expand the terms of Fairchild's worldwide terms and conditions, specifically the warranty therein, which covers Fairchild products.

Always visit Fairchild Semiconductor's online packaging area for the most recent package drawings:
<http://www.fairchildsemi.com/packaging/>

Physical Dimensions

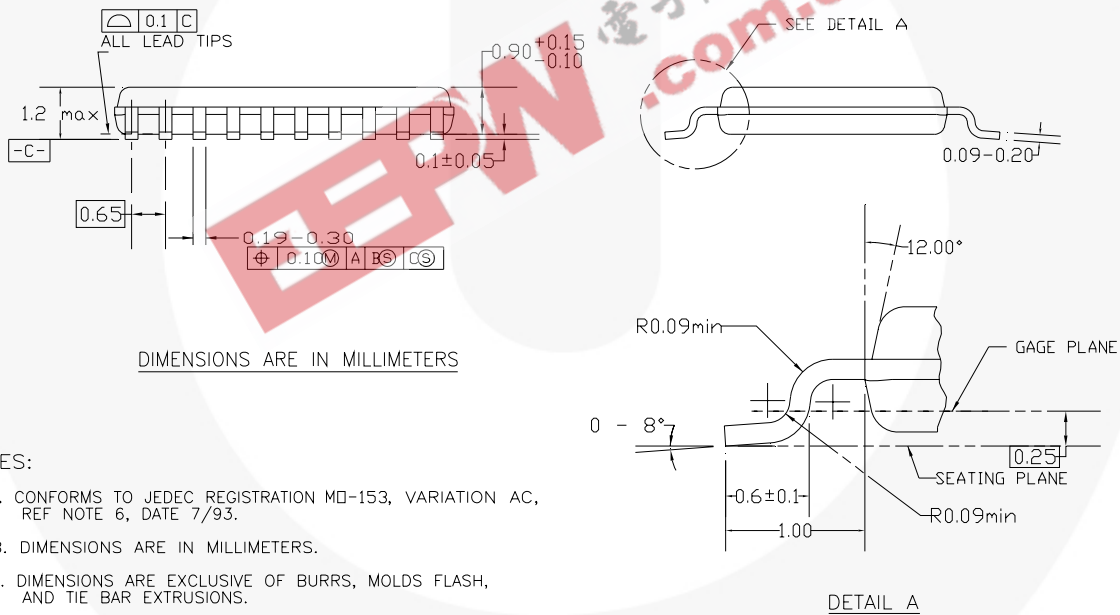
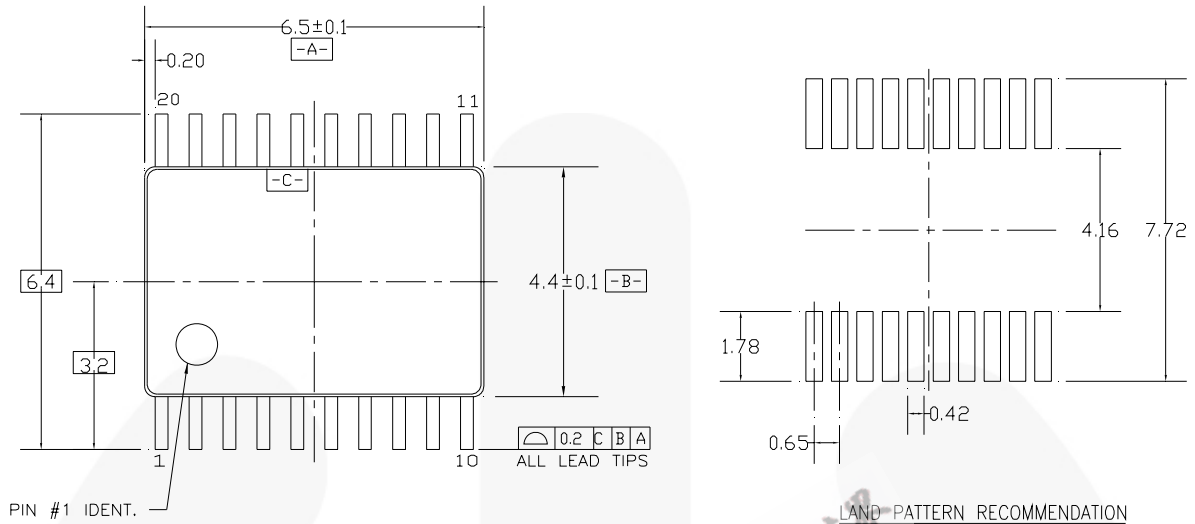

DIMENSIONS ARE IN MILLIMETERS

NOTES:

- A. CONFORMS TO JEDEC REGISTRATION MO-153, VARIATION AC, REF NOTE 6, DATE 7/93.
- B. DIMENSIONS ARE IN MILLIMETERS.
- C. DIMENSIONS ARE EXCLUSIVE OF BURRS, MOLDS FLASH, AND TIE BAR EXTRUSIONS.
- D. DIMENSIONS AND TOLERANCES PER ANSI Y14.5M, 1982.

MTC20REV D1

Figure 7. 20-Lead Thin Shrink Small Outline Package (TSSOP), JEDEC MO-153, 4.4mm Wide





Package drawings are provided as a service to customers considering Fairchild components. Drawings may change in any manner without notice. Please note the revision and/or date on the drawing and contact a Fairchild Semiconductor representative to verify or obtain the most recent revision. Package specifications do not expand the terms of Fairchild's worldwide terms and conditions, specifically the warranty therein, which covers Fairchild products.

Always visit Fairchild Semiconductor's online packaging area for the most recent package drawings:
<http://www.fairchildsemi.com/packaging/>



TRADEMARKS

The following includes registered and unregistered trademarks and service marks, owned by Fairchild Semiconductor and/or its global subsidiaries, and is not intended to be an exhaustive list of all such trademarks.

- | | | | |
|---|-------------------------------------|---|---|
| ACEX® | FPS™ | PDP-SPM™ | The Power Franchise® |
| Build it Now™ | F-PFS™ | Power-SPM™ |  |
| CorePLUS™ | FRFET® | PowerTrench® | TinyBoost™ |
| CorePOWER™ | Global Power Resource SM | Program mable Active Droop™ | TinyBuck™ |
| CROSSVOLT™ | Green FPS™ | QFET® | TinyLogic® |
| CTL™ | Green FPS™ e-Series™ | QS™ | TINYOPTO™ |
| Current Transfer Logic™ | GTO™ | Quiet Series™ | TinyPower™ |
| EcoSPARK® | IntelliMAX™ | RapidConfigure™ | TinyPWM™ |
| EfficientMax™ | ISOPLANAR™ | Saving our world, 1mW at a time™ | TinyWire™ |
| EZSWITCH™ * | MegaBuck™ | SmartMax™ | μSerDes™ |
|  | MICROCOUPLER™ | SMART-START™ |  |
|  | MicroFET™ | SPM® | UHC® |
| Fairchild® | MicroPak™ | STEALTH™ | Ultra FRFET™ |
| Fairchild Semiconductor® | MillerDrive™ | SuperFET™ | UniFET™ |
| FACT Quiet Series™ | MotionMax™ | SuperSOT™-3 | VCX™ |
| FACT® | Motion-SPM™ | SuperSOT™-6 | VisualMax™ |
| FAST® | OPTOLOGIC® | SuperSOT™-8 | |
| FastvCore™ | OPTOPLANAR® | SupreMOS™ | |
| FlashWriter® * | | SyncFET™ | |
| | |  | |

* EZSWITCH™ and FlashWriter® are trademarks of System General Corporation, used under license by Fairchild Semiconductor.

DISCLAIMER

FAIRCHILD SEMICONDUCTOR RESERVES THE RIGHT TO MAKE CHANGES WITHOUT FURTHER NOTICE TO ANY PRODUCTS HEREIN TO IMPROVE RELIABILITY, FUNCTION, OR DESIGN. FAIRCHILD DOES NOT ASSUME ANY LIABILITY ARISING OUT OF THE APPLICATION OR USE OF ANY PRODUCT OR CIRCUIT DESCRIBED HEREIN; NEITHER DOES IT CONVEY ANY LICENSE UNDER ITS PATENT RIGHTS, NOR THE RIGHTS OF OTHERS. THESE SPECIFICATIONS DO NOT EXPAND THE TERMS OF FAIRCHILD'S WORLDWIDE TERMS AND CONDITIONS, SPECIFICALLY THE WARRANTY THEREIN, WHICH COVERS THESE PRODUCTS.

LIFE SUPPORT POLICY

FAIRCHILD'S PRODUCTS ARE NOT AUTHORIZED FOR USE AS CRITICAL COMPONENTS IN LIFE SUPPORT DEVICES OR SYSTEMS WITHOUT THE EXPRESS WRITTEN APPROVAL OF FAIRCHILD SEMICONDUCTOR CORPORATION.

As used herein:

1. Life support devices or systems are devices or systems which, (a) are intended for surgical implant into the body or (b) support or sustain life, and (c) whose failure to perform when properly used in accordance with instructions for use provided in the labeling, can be reasonably expected to result in a significant injury of the user.
2. A critical component in any component of a life support, device, or system whose failure to perform can be reasonably expected to cause the failure of the life support device or system, or to affect its safety or effectiveness.

PRODUCT STATUS DEFINITIONS

Definition of Terms

Datasheet Identification	Product Status	Definition
Advance Information	Formative / In Design	This datasheet contains the design specifications for product development. Specifications may change in any manner without notice.
Preliminary	First Production	This datasheet contains preliminary data; supplementary data will be published at a later date. Fairchild Semiconductor reserves the right to make changes at any time without notice to improve design.
No Identification Needed	Full Production	This datasheet contains final specifications. Fairchild Semiconductor reserves the right to make changes at any time without notice to improve the design.
Obsolete	Not In Production	This datasheet contains specifications on a product that is discontinued by Fairchild Semiconductor. The datasheet is for reference information only.

Rev. I34