



LM2002/LM2002A 8 Watt Audio Power Amplifier

General Description

The LM2002 is a cost effective, high power amplifier suited for automotive applications. High current capability (3.5A) enables the device to drive low impedance loads with low distortion. The LM2002 is current limited and thermally protected. High voltage protection is available (LM2002A) which enables the amplifier to withstand 40V transients on its supply. The LM2002 comes in a 5-pin TO-220 package.

Features

- High peak current capability (3.5A)
- Large output voltage swing

- Externally programmable gain
- Wide supply voltage range (5V–20V)
- Few external parts required
- Low distortion
- High input impedance
- No turn-on transients
- High voltage protection available (LM2002A)
- Low noise
- AC short circuit protected
- Pin for pin compatible with TDA2002

Equivalent Schematic

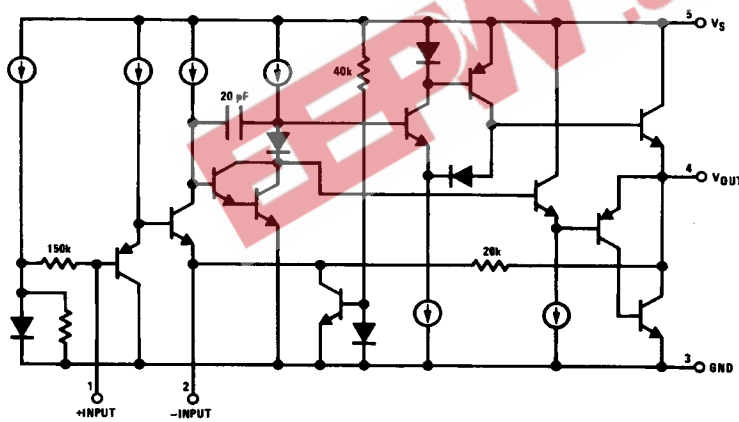

TL/H/7929-1

Connection Diagram

Plastic Package

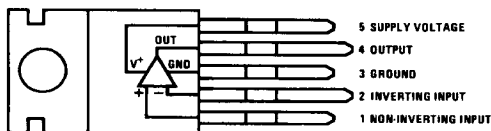

TL/H/7929-2

Order Number LM2002T or LM2002AT
See NS Package Number T05A

Typical Application

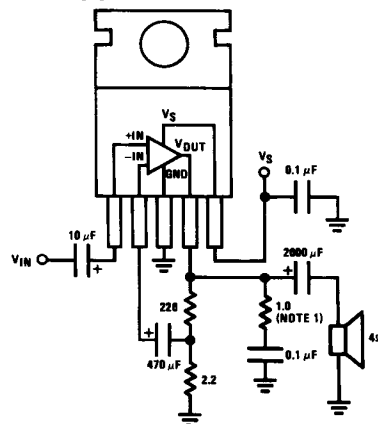

TL/H/7929-3

LM2002/LM2002A

1

Absolute Maximum Ratings

If Military/Aerospace specified devices are required, please contact the National Semiconductor Sales Office/Distributors for availability and specifications.

Peak Supply Voltage (50 ms)		Output Current	
LM2002A (Note 2)	40V	Repetitive	3.5A
LM2002	25V	Non-repetitive	4.5A
Operating Supply Voltage	20V	Input Voltage	$\pm 0.5V$
		Power Dissipation (Note 3)	15W
		Operating Temperature	0°C to +70°C
		Storage Temperature	-60°C to +150°C
		Lead Temperature (Soldering, 10 sec.)	260°C

Electrical Characteristics

$V_S = 14.4V$, $T_{TAB} = 25^\circ C$, $A_V = 100$ (40 dB), $R_L = 4\Omega$, unless otherwise specified

Parameter	Conditions	Min	Typ	Max	Units
DC Output Level		6.4	7.2	8	V
Quiescent Supply Current	Excludes Current in Feedback Resistors		45	80	mA
Supply Voltage Range		5		20	V
Input Resistance			150		k Ω
Bandwidth	Gain = 40 dB		100		kHz
Output Power	$V_S = 13.2V$, $f = 1$ kHz		4.3		W
	$R_L = 4\Omega$, THD = 10%		6.5		W
	$R_L = 2\Omega$, THD = 10%		4.8		W
	$V_S = 13.8V$, $f = 1$ kHz		7.4		W
	$R_L = 4\Omega$, THD = 10%		4.8		W
	$R_L = 2\Omega$, THD = 10%		7.4		W
	$V_S = 14.4V$, $f = 1$ kHz		4.8		W
	$R_L = 4\Omega$, THD = 10%	4.8	5.2		W
	$R_L = 2\Omega$, THD = 10%	7	8		W
	$R_L = 1.6\Omega$, THD = 10%		9		W
THD	$P_O = 2W$, $R_L = 4\Omega$, $f = 1$ kHz		0.1		%
	$P_O = 4W$, $R_L = 2\Omega$, $f = 1$ kHz		0.1		%
Ripple Rejection	$R_S = 50\Omega$, $f = 100$ Hz	30	40		dB
	$R_S = 50\Omega$, $f = 1$ kHz		44		dB
Input Noise Voltage	$R_S = 0$, 15 kHz Bandwidth		2		μV
Input Noise Current	$R_S = 100$ k Ω , 15 kHz Bandwidth		40		pA

Note 1: A 1.0 resistor and 0.1 μF capacitor should be placed as close as possible to pins 3 and 4 for stability.

Note 2: The LM2002 shuts down above 25V.

Note 3: For operating at elevated temperatures, the device must be derated based on a 150°C maximum junction temperature and a thermal resistance of 4°C/W junction to case.

Typical Performance Characteristics

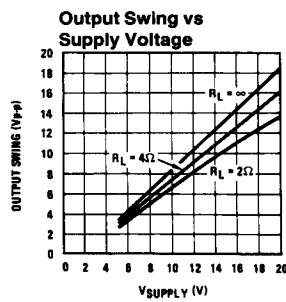
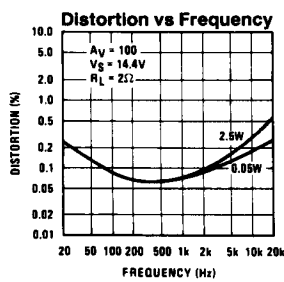
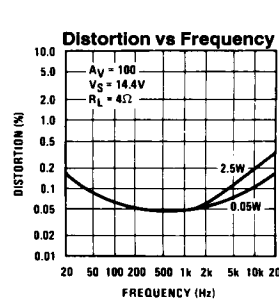
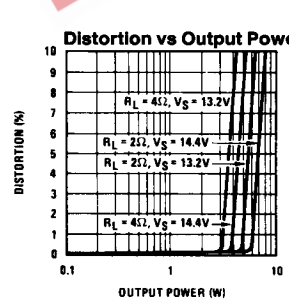
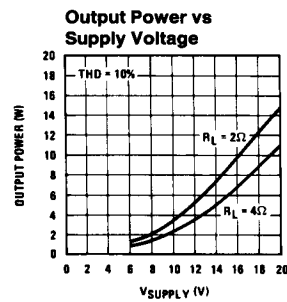
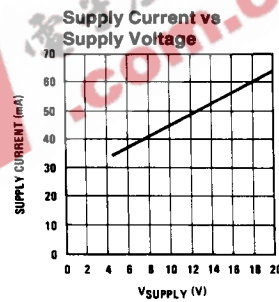
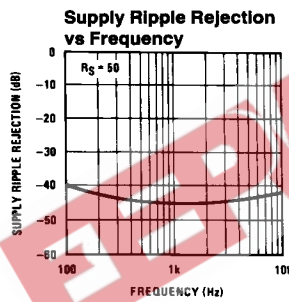
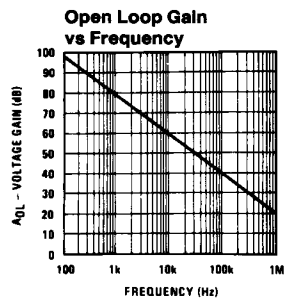
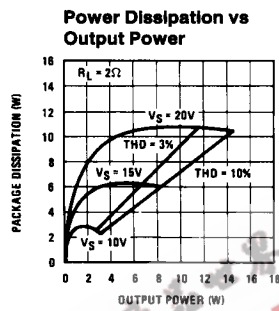
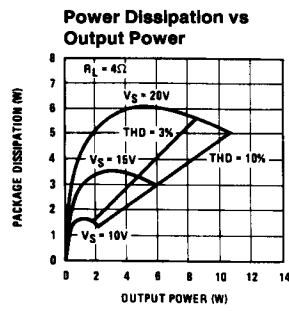
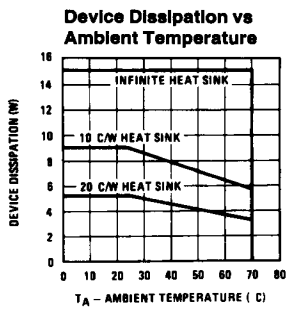

1

Typical Applications (Continued)

16W Bridge Amplifier

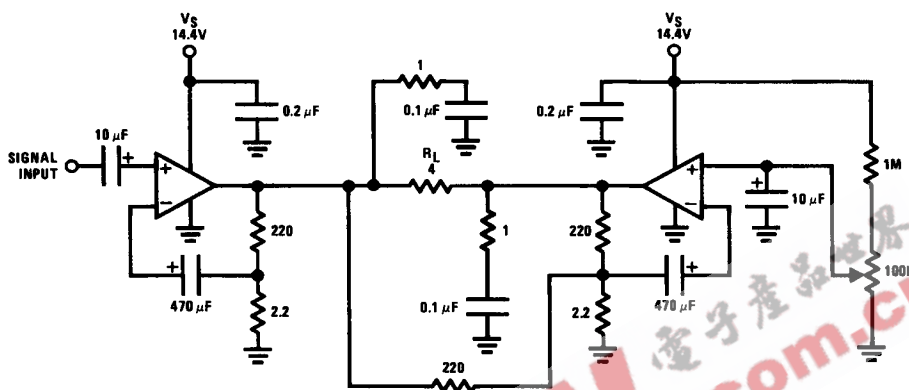

TL/H/7929-5

Component Layout

Single Amplifier
 $V_S = 20V$
 $R_L = 4\Omega$

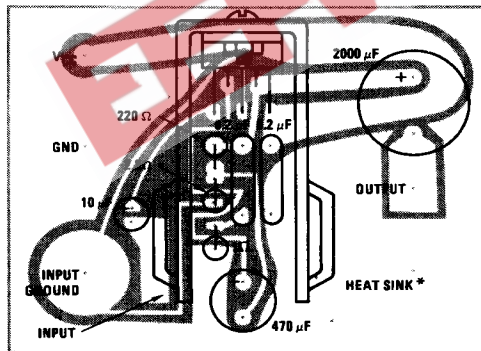

TL/H/7929-6

*Staver V-5 Heatsink
 Staver Company
 41 Saxon Ave
 P.O. Drawer H
 Bayshore, NY 11706
 TEL: (516) 666-8000