

8 BIT REGISTER BINARY COUNTER

- HIGH SPEED
 $f_{MAX} = 35 \text{ MHz (TYP.) AT } V_{CC} = 5 \text{ V}$
- LOW POWER DISSIPATION
 $I_{CC} = 4 \mu\text{A (MAX.) AT } T_A = 25 \text{ }^\circ\text{C}$
- OUTPUT DRIVE CAPABILITY
 10 LSTTL LOADS
- BALANCED PROPAGATION DELAYS
 $t_{PLH} = t_{PHL}$
- SYMMETRICAL OUTPUT IMPEDANCE
 $I_{OL} = |I_{OH}| = 4 \text{ mA (MIN.)}$
- HIGH NOISE IMMUNITY
 $V_{NIH} = V_{NIL} = 28 \% V_{CC} \text{ (MIN.)}$
- WIDE OPERATING VOLTAGE RANGE
 $V_{CC} \text{ (OPR)} = 2 \text{ V TO } 6 \text{ V}$
- PIN AND FUNCTION COMPATIBLE
 WITH 54/74LS592

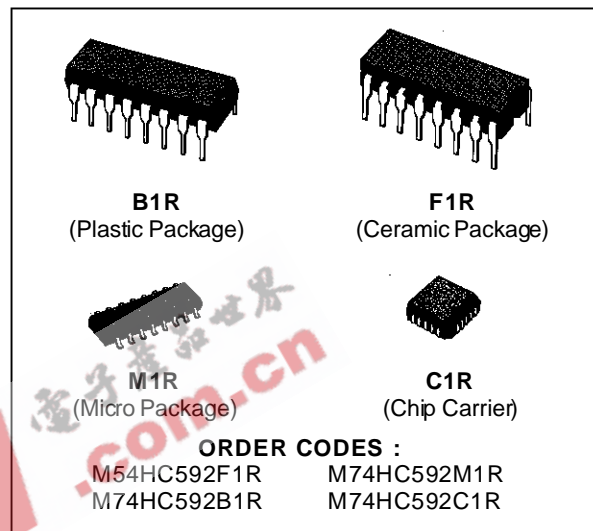

DESCRIPTION

The M54/74HC592 is a high speed CMOS 8 BIT REGISTER COUNTER fabricated in silicon gate C²MOS technology. It has the same high speed performance of LSTTL combined with true CMOS low power consumption.

The M54/74HC592 is a parallel input, 8 bit storage register feeding an 8 bit binary counter. Both the register and the counter have individual positive edge triggered clock. In addition, the counter has direct load and clear functions. Expansion is easily accomplished by connecting $\overline{\text{RCO}}$ of the first stage to the count enable of the second stage. All inputs are equipped with protection circuits against static discharge and transient excess voltage.

INPUT AND OUTPUT EQUIVALENT CIRCUIT

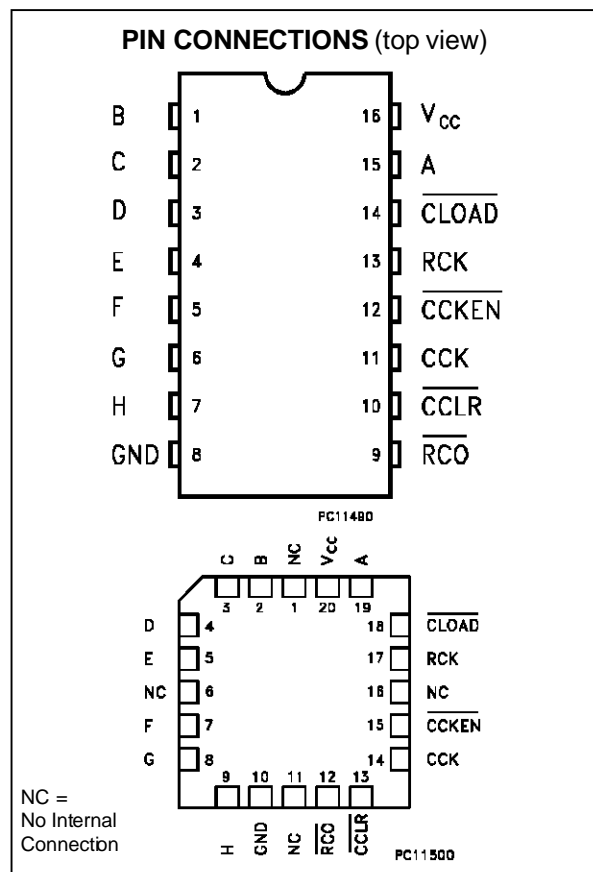
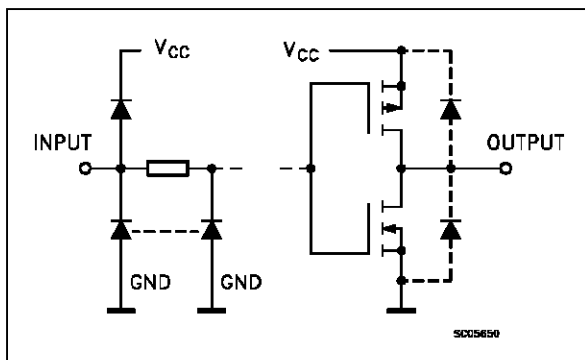

M54/M74HC592

TRUTH TABLE

INPUTS					FUNCTION
RCK	$\overline{\text{CLOAD}}$	$\overline{\text{CCLR}}$	$\overline{\text{CCKEN}}$	CCK	
X	L	H	X	X	REGISTER DATA IS LOADED INTO COUNTER
X	H	L	X	X	COUNTER CLEAR
$\overline{\square}$	H	H	X	X	THE DATA OF A THRU H INPUTS IS STORED INTO REGISTER
$\overline{\square}$	H	H	X	X	REGISTER STATE IS NOT CHANGED
X	H	H	L	$\overline{\square}$	COUNTER ADVANCES THE COUNT
X	H	H	L	$\overline{\square}$	NO COUNT
X	H	H	H	X	NO COUNT

X: Don't Care

$$\text{RCO} = \text{QA}' \cdot \text{QB}' \cdot \text{QC}' \cdot \text{QD}' \cdot \text{QE}' \cdot \text{QF}' \cdot \text{QG}' \cdot \text{QH}'$$

(QA' to QH': Internal outputs of the counter)

TIMING CHART

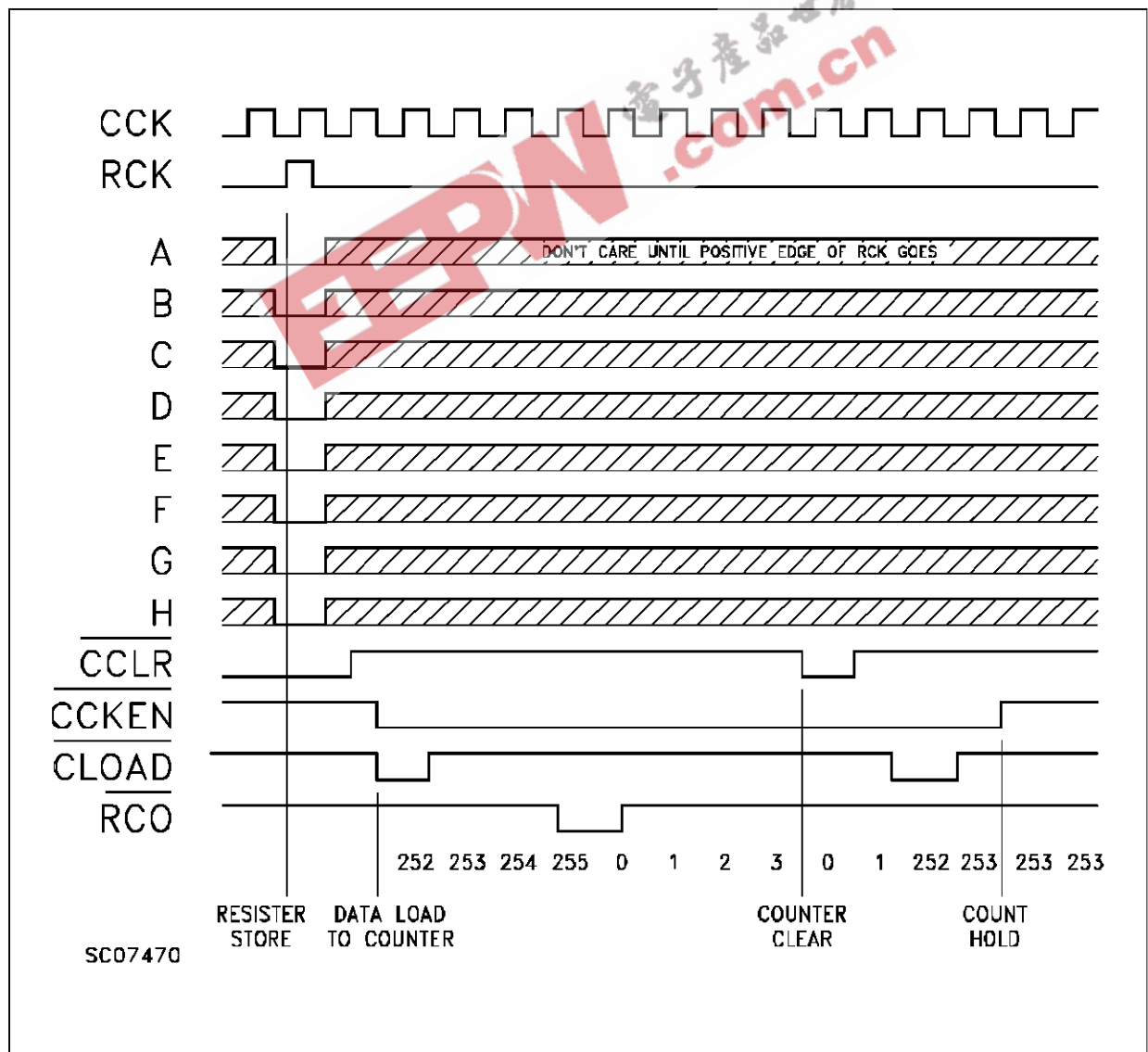

LOGIC DIAGRAM

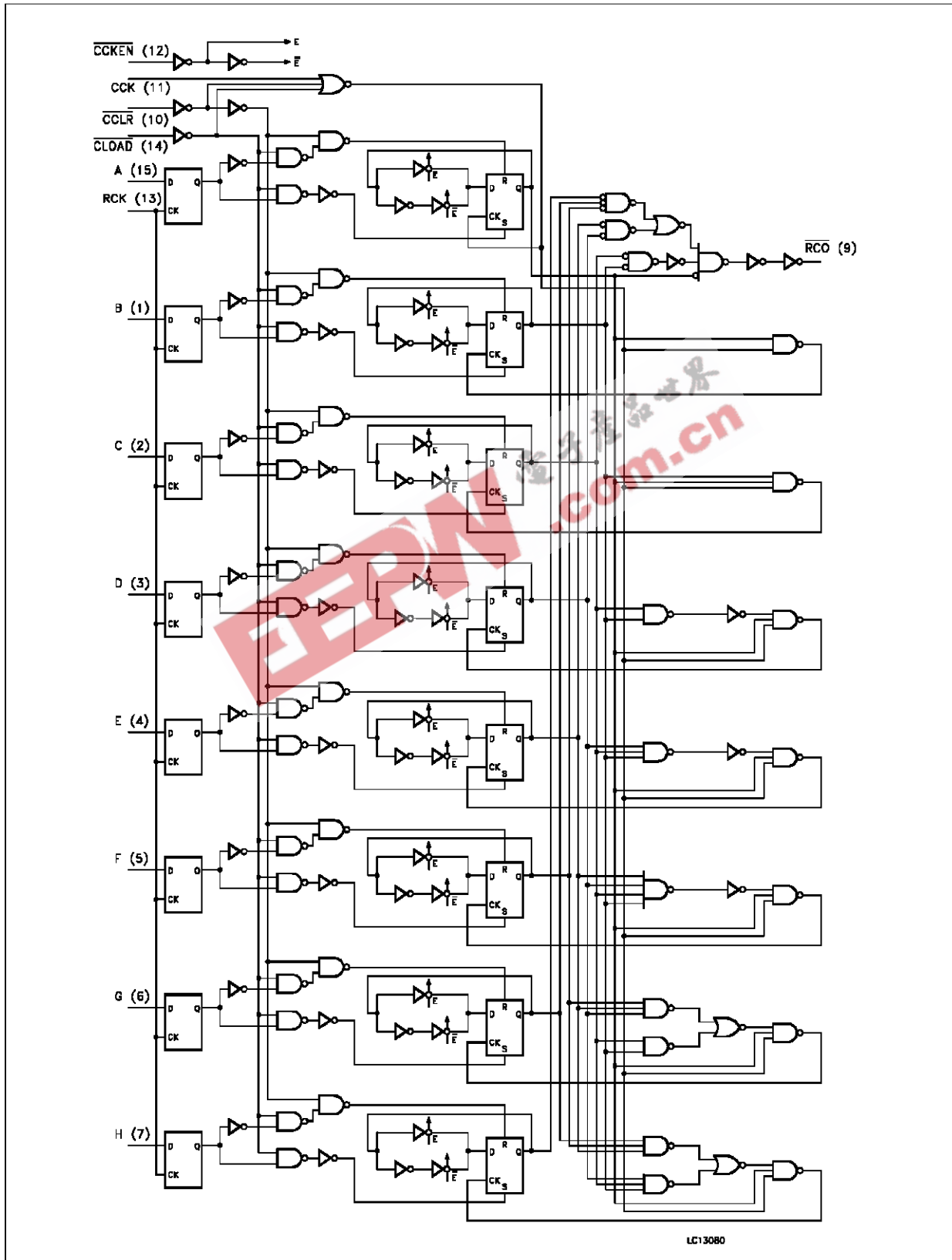

M54/M74HC592

BLOCK DIAGRAM

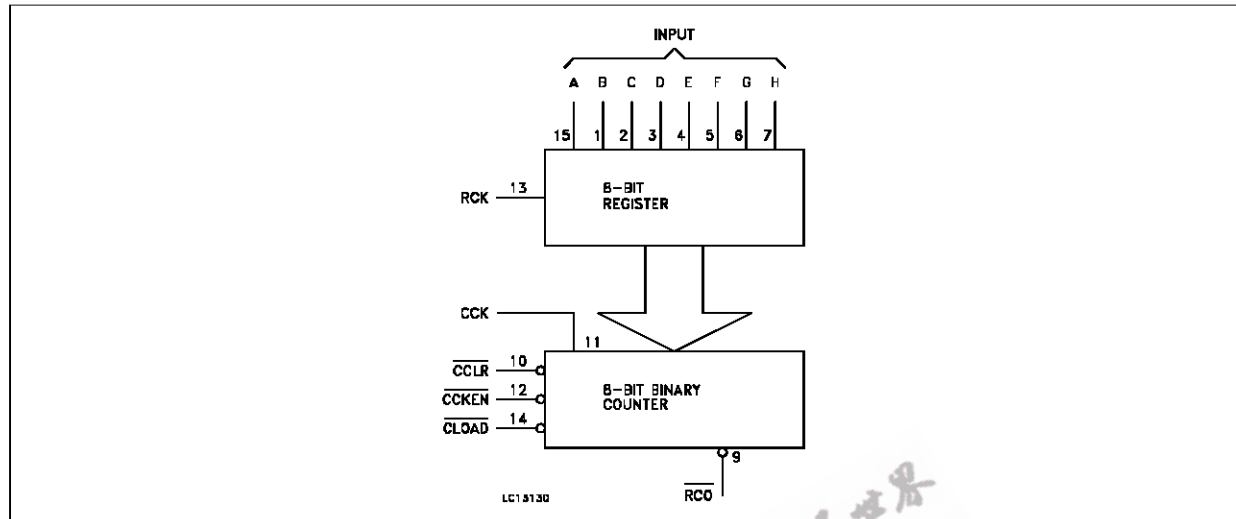

PIN DESCRIPTION

PIN No	SYMBOL	NAME AND FUNCTION
1 to 7, 15	A to H	Data Inputs
9	RCO	Ripple Counter Output
10	CCLR	Counter Clear Input
11	CCK	Counter Clock Input
12	CCKEN	Counter Clock Enable Input
13	RCK	Register Clock Input
14	CLOAD	Counter Load Input
8	GND	Ground (0V)
16	V _{CC}	Positive Supply Voltage

IEC LOGIC SYMBOL

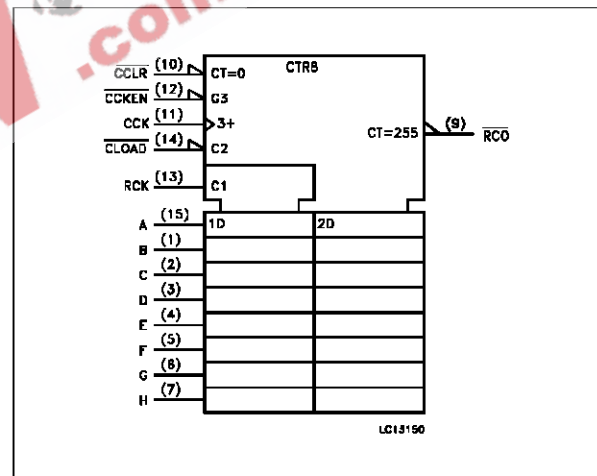

ABSOLUTE MAXIMUM RATINGS

Symbol	Parameter	Value	Unit
V _{CC}	Supply Voltage	-0.5 to +7	V
V _I	DC Input Voltage	-0.5 to V _{CC} + 0.5	V
V _O	DC Output Voltage	-0.5 to V _{CC} + 0.5	V
I _{IK}	DC Input Diode Current	± 20	mA
I _{OK}	DC Output Diode Current	± 20	mA
I _O	DC Output Source Sink Current Per Output Pin	± 25	mA
I _{CC} or I _{GND}	DC V _{CC} or Ground Current	± 50	mA
P _D	Power Dissipation	500 (*)	mW
T _{stg}	Storage Temperature	-65 to +150	°C
T _L	Lead Temperature (10 sec)	300	°C

Absolute Maximum Ratings are those values beyond which damage to the device may occur. Functional operation under these condition is not implied.

(*) 500 mW: ≅ 65 °C derate to 300 mW by 10mW/°C: 65 °C to 85 °C

RECOMMENDED OPERATING CONDITIONS

Symbol	Parameter	Value	Unit
V_{CC}	Supply Voltage	2 to 6	V
V_I	Input Voltage	0 to V_{CC}	V
V_O	Output Voltage	0 to V_{CC}	V
T_{op}	Operating Temperature: M54HC Series M74HC Series	-55 to +125 -40 to +85	°C °C
t_r, t_f	Input Rise and Fall Time	$V_{CC} = 2\text{ V}$	0 to 1000
		$V_{CC} = 4.5\text{ V}$	0 to 500
		$V_{CC} = 6\text{ V}$	0 to 400

DC SPECIFICATIONS

Symbol	Parameter	Test Conditions		Value						Unit	
				$T_A = 25\text{ °C}$ 54HC and 74HC			$-40\text{ to }85\text{ °C}$ 74HC		$-55\text{ to }125\text{ °C}$ 54HC		
				Min.	Typ.	Max.	Min.	Max.	Min.		Max.
V_{IH}	High Level Input Voltage	2.0 4.5 6.0		1.5			1.5		1.5	V	
				3.15			3.15		3.15		
				4.2			4.2		4.2		
V_{IL}	Low Level Input Voltage	2.0 4.5 6.0				0.5		0.5	0.5	V	
						1.35		1.35	1.35		
						1.8		1.8	1.8		
V_{OH}	High Level Output Voltage	2.0 4.5 6.0 4.5 6.0	$V_I = V_{IH}$ or V_{IL}	$I_O = -20\text{ }\mu\text{A}$ $I_O = -4.0\text{ mA}$ $I_O = -5.2\text{ mA}$	1.9	2.0		1.9		1.9	V
					4.4	4.5		4.4		4.4	
					5.9	6.0		5.9		5.9	
					4.18	4.31		4.13		4.10	
					5.68	5.8		5.63		5.60	
V_{OL}	Low Level Output Voltage	2.0 4.5 6.0 4.5 6.0	$V_I = V_{IH}$ or V_{IL}	$I_O = 20\text{ }\mu\text{A}$ $I_O = 4.0\text{ mA}$ $I_O = 5.2\text{ mA}$		0.0	0.1		0.1	0.1	V
						0.0	0.1		0.1	0.1	
						0.0	0.1		0.1	0.1	
						0.17	0.26		0.33	0.40	
						0.18	0.26		0.33	0.40	
I_I	Input Leakage Current	6.0	$V_I = V_{CC}$ or GND			± 0.1		± 1	± 1	μA	
I_{CC}	Quiescent Supply Current	6.0	$V_I = V_{CC}$ or GND			4		40	80	μA	

M54/M74HC592

AC ELECTRICAL CHARACTERISTICS (C_L = 50 pF, Input t_r = t_f = 6 ns)

Symbol	Parameter	Test Conditions		Value						Unit	
		V _{CC} (V)		T _A = 25 °C 54HC and 74HC			-40 to 85 °C 74HC		-55 to 125 °C 54HC		
				Min.	Typ.	Max.	Min.	Max.	Min.		Max.
t _{TLH} t _{THL}	Output Transition Time	2.0			30	75		95		110	ns
		4.5			8	15		19		22	
		6.0			7	13		16		19	
t _{PLH} t _{PHL}	Propagation Delay Time (CCK - RCO)	2.0			63	165		205		250	ns
		4.5			21	33		41		50	
		6.0			18	28		35		43	
t _{PLH} t _{PHL}	Propagation Delay Time (CLOAD - RCO)	2.0			110	235		295		355	ns
		4.5			30	47		59		71	
		6.0			26	40		50		60	
t _{PHL}	Propagation Delay Time (CCLR - RCO)	2.0			70	160		200		240	ns
		4.5			20	32		40		48	
		6.0			17	27		34		41	
t _{PLH} t _{PHL}	Propagation Delay Time (RCK - RCO)	2.0			120	260		325		390	ns
		4.5			34	52		65		78	
		6.0			29	44		55		66	
f _{MAX}	Maximum Clock Frequency	2.0			5.4	11		4.4		3.6	MHz
		4.5			27	45		22		18	
		6.0			32	53		26		21	
t _{W(H)} t _{W(L)}	Minimum Pulse Width	2.0			40	75		95		110	ns
		4.5			8	15		19		22	
		6.0			7	13		16		19	
t _{W(L)}	Minimum Pulse Width (CCLR, CLOAD)	2.0			40	75		95		110	ns
		4.5			8	15		19		22	
		6.0			7	13		16		19	
t _s	Minimum Set-up Time (CCKEN - CCK)	2.0			28	75		95		110	ns
		4.5			7	15		19		22	
		6.0			6	13		16		19	
t _s	Minimum Set-up Time (RCK - CLOAD) (A ... H - RCK)	2.0			40	100		125		145	ns
		4.5			10	20		25		29	
		6.0			9	17		21		25	
t _h	Minimum Hold Time	2.0				0		0		0	ns
		4.5				0		0		0	
		6.0				0		0		0	
t _{REM}	Minimum Removal Time	2.0			28	75		95		110	ns
		4.5			7	15		19		22	
		6.0			6	13		16		19	
C _{IN}	Input Capacitance				5	10		10		10	pF
C _{PD} (*)	Power Dissipation Capacitance				30						pF

(*) C_{PD} is defined as the value of the IC's internal equivalent capacitance which is calculated from the operating current consumption without load. (Refer to Test Circuit). Average operating current can be obtained by the following equation. I_{CC(OPR)} = C_{PD} • V_{CC} • f_{IN} + I_{CC}

SWITCHING CHARACTERISTICS TEST WAVEFORM

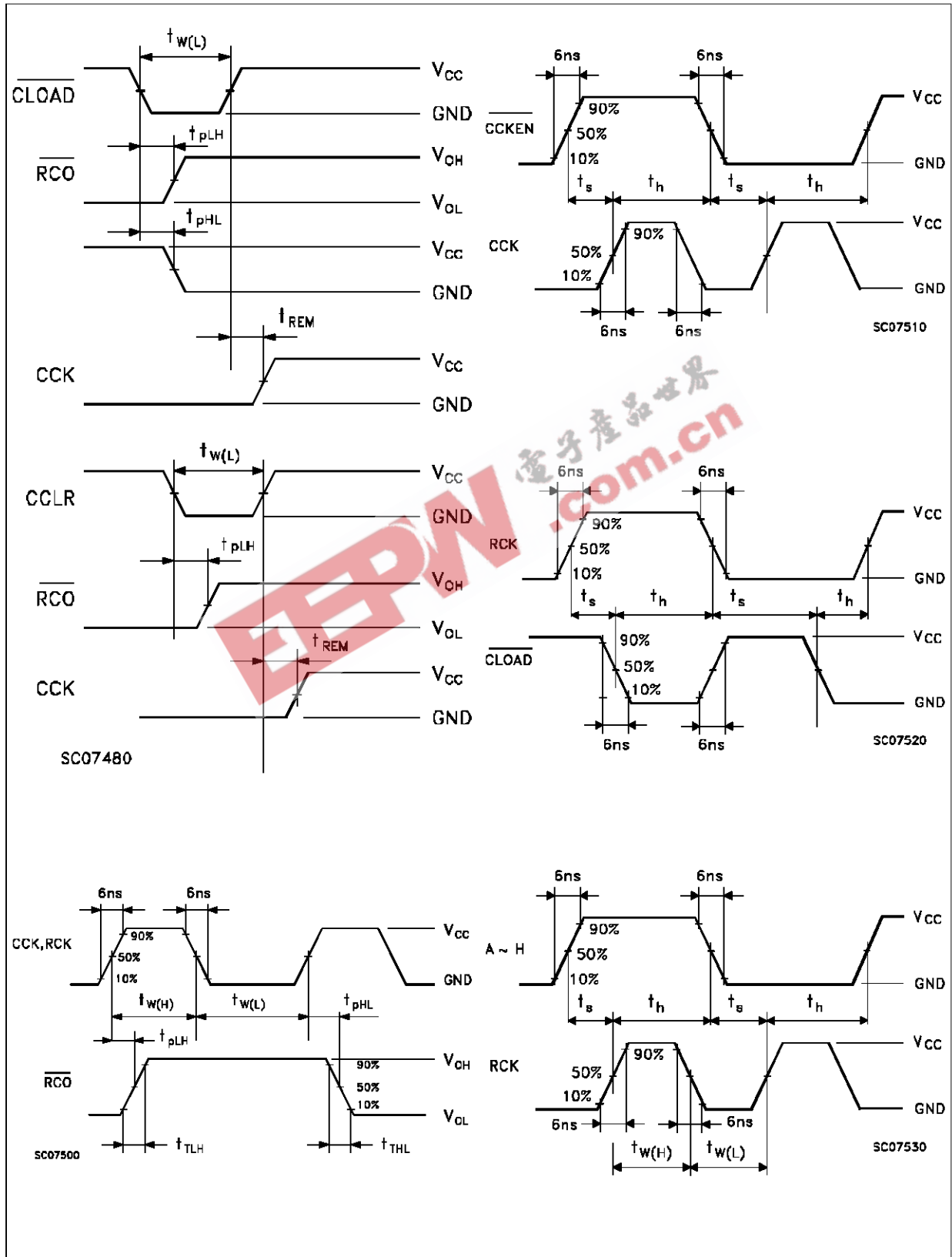

M54/M74HC592

I_{CC} (Opr.) TEST CIRCUIT

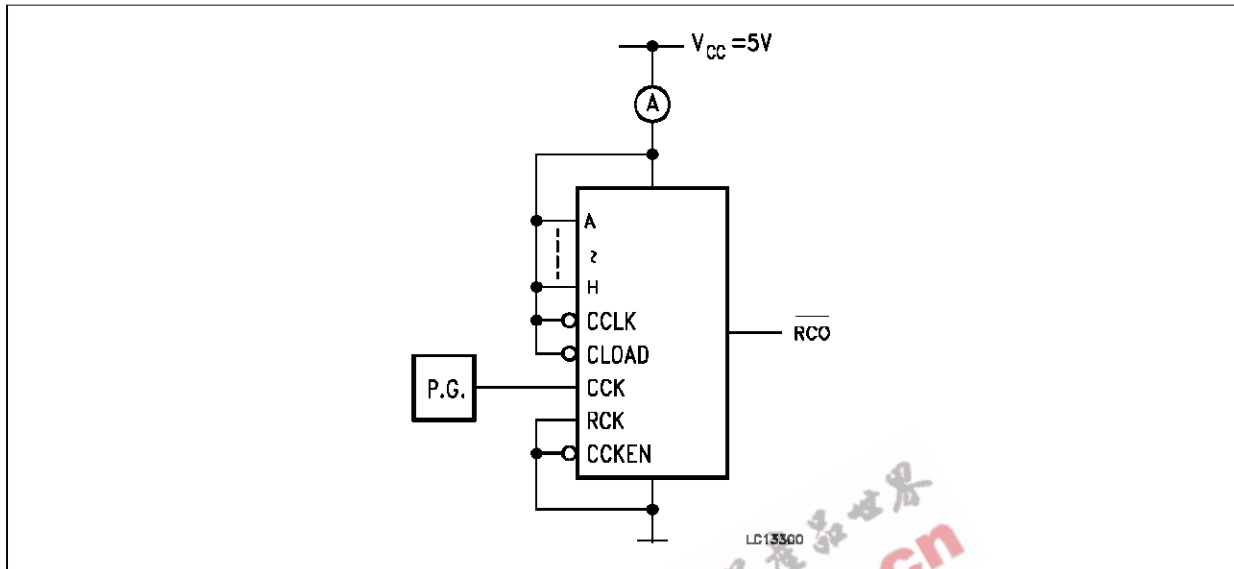

Plastic DIP16 (0.25) MECHANICAL DATA

DIM.	mm			inch		
	MIN.	TYP.	MAX.	MIN.	TYP.	MAX.
a1	0.51			0.020		
B	0.77		1.65	0.030		0.065
b		0.5			0.020	
b1		0.25			0.010	
D			20			0.787
E		8.5			0.335	
e		2.54			0.100	
e3		17.78			0.700	
F			7.1			0.280
I			5.1			0.201
L		3.3			0.130	
Z			1.27			0.050

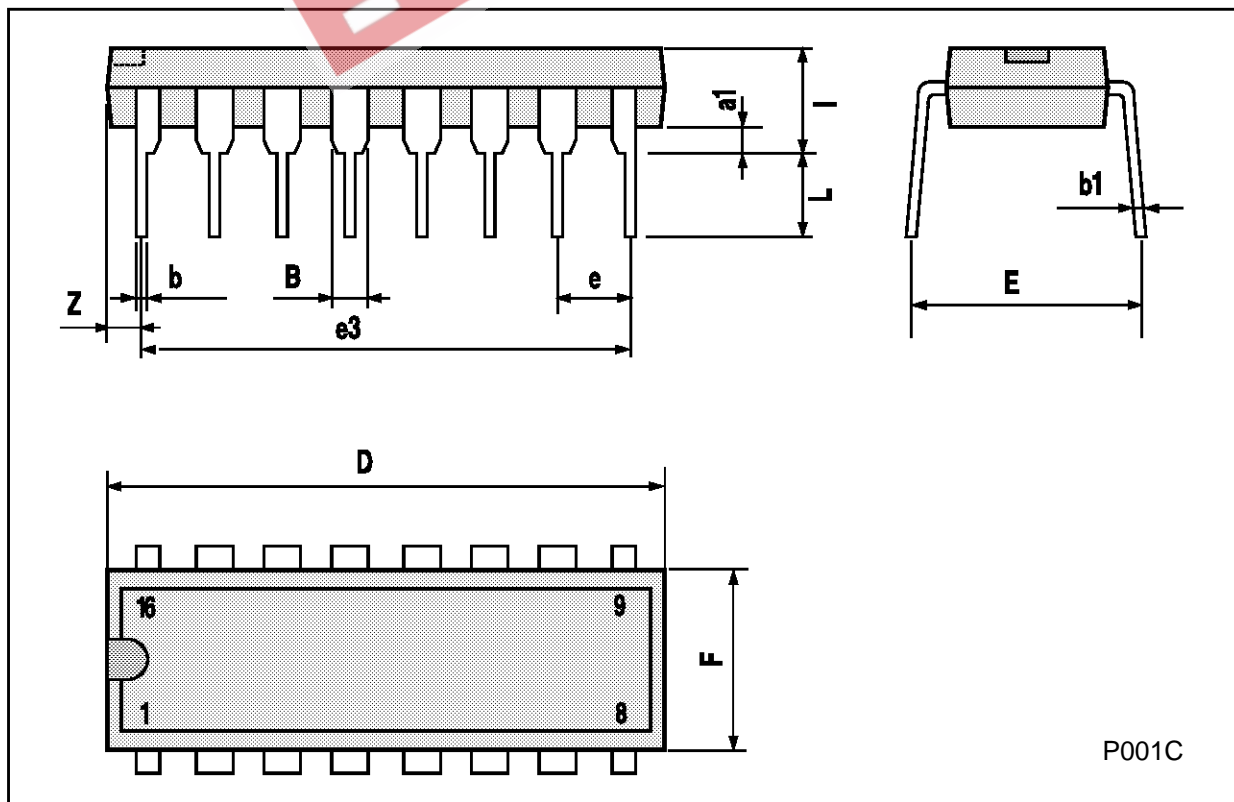

M54/M74HC592

Ceramic DIP16/1 MECHANICAL DATA

DIM.	mm			inch		
	MIN.	TYP.	MAX.	MIN.	TYP.	MAX.
A			20			0.787
B			7			0.276
D		3.3			0.130	
E	0.38			0.015		
e3		17.78			0.700	
F	2.29		2.79	0.090		0.110
G	0.4		0.55	0.016		0.022
H	1.17		1.52	0.046		0.060
L	0.22		0.31	0.009		0.012
M	0.51		1.27	0.020		0.050
N			10.3			0.406
P	7.8		8.05	0.307		0.317
Q			5.08			0.200

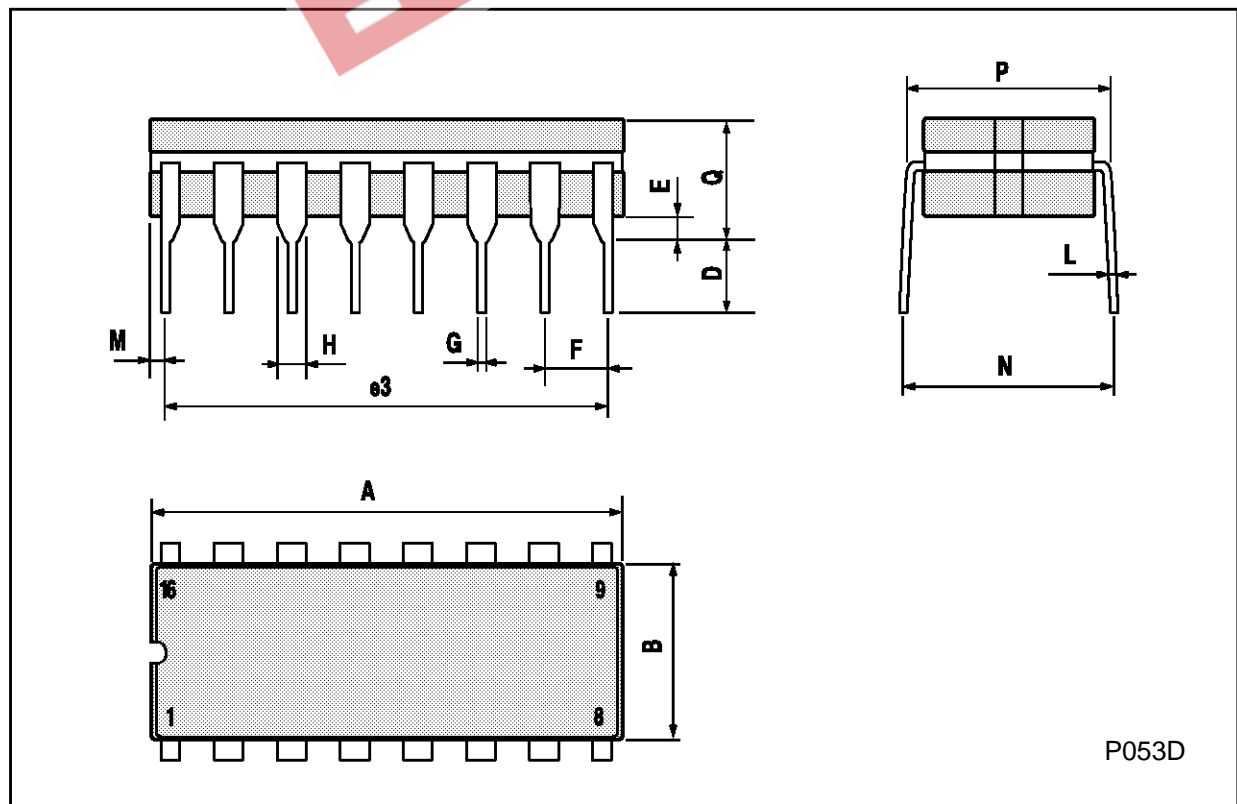

P053D

SO16 (Narrow) MECHANICAL DATA

DIM.	mm			inch		
	MIN.	TYP.	MAX.	MIN.	TYP.	MAX.
A			1.75			0.068
a1	0.1		0.2	0.004		0.007
a2			1.65			0.064
b	0.35		0.46	0.013		0.018
b1	0.19		0.25	0.007		0.010
C		0.5			0.019	
c1	45° (typ.)					
D	9.8		10	0.385		0.393
E	5.8		6.2	0.228		0.244
e		1.27			0.050	
e3		8.89			0.350	
F	3.8		4.0	0.149		0.157
G	4.6		5.3	0.181		0.208
L	0.5		1.27	0.019		0.050
M			0.62			0.024
S	8° (max.)					

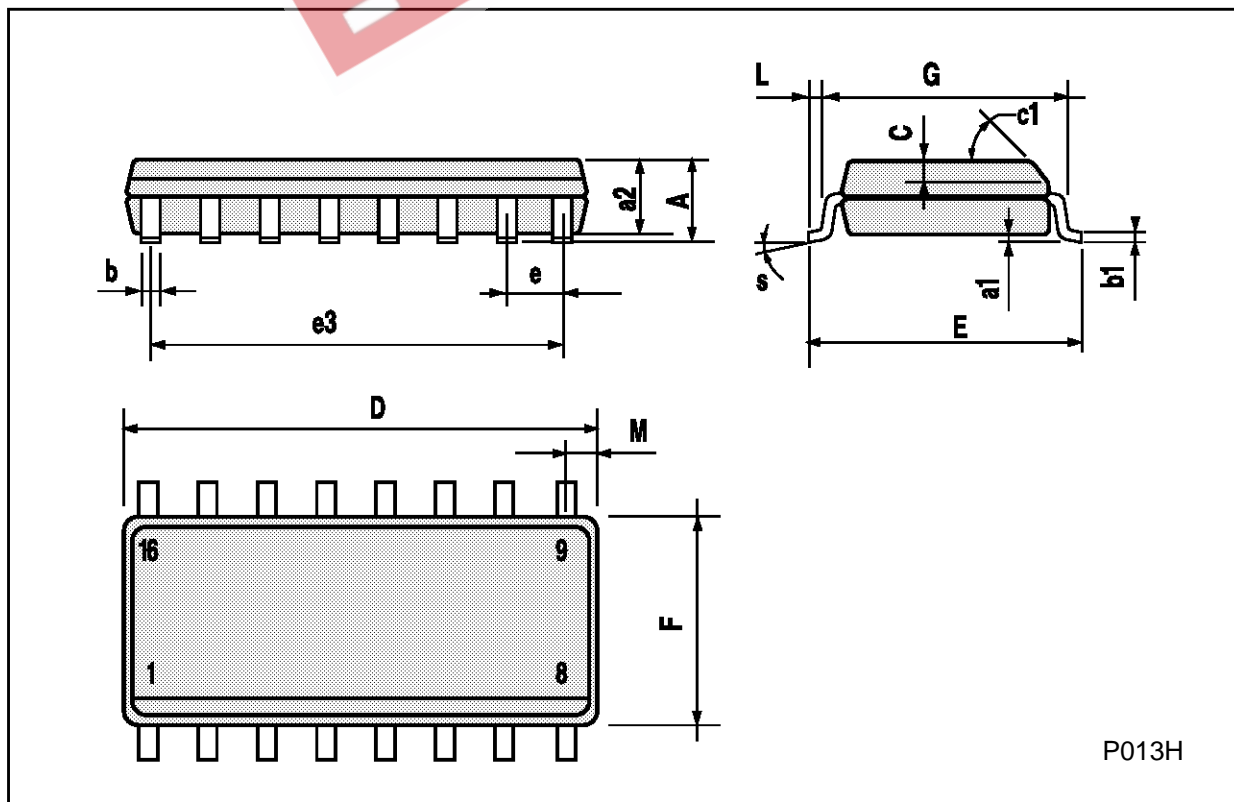

PLCC20 MECHANICAL DATA

DIM.	mm			inch		
	MIN.	TYP.	MAX.	MIN.	TYP.	MAX.
A	9.78		10.03	0.385		0.395
B	8.89		9.04	0.350		0.356
D	4.2		4.57	0.165		0.180
d1		2.54			0.100	
d2		0.56			0.022	
E	7.37		8.38	0.290		0.330
e		1.27			0.050	
e3		5.08			0.200	
F		0.38			0.015	
G			0.101			0.004
M		1.27			0.050	
M1		1.14			0.045	

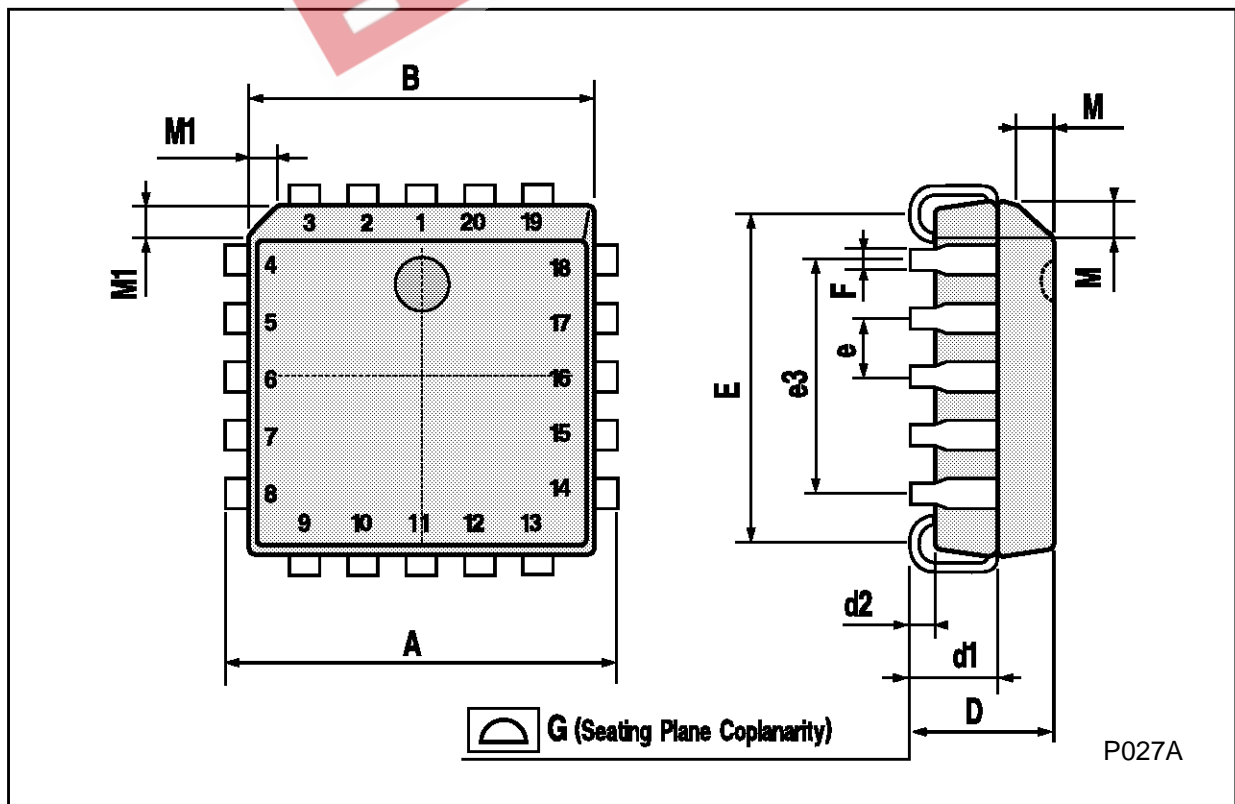

EEPW 电子產品世界
.com.cn

Information furnished is believed to be accurate and reliable. However, SGS-THOMSON Microelectronics assumes no responsibility for the consequences of use of such information nor for any infringement of patents or other rights of third parties which may result from its use. No license is granted by implication or otherwise under any patent or patent rights of SGS-THOMSON Microelectronics. Specifications mentioned in this publication are subject to change without notice. This publication supersedes and replaces all information previously supplied. SGS-THOMSON Microelectronics products are not authorized for use as critical components in life support devices or systems without express written approval of SGS-THOMSON Microelectronics.

© 1994 SGS-THOMSON Microelectronics - All Rights Reserved

SGS-THOMSON Microelectronics GROUP OF COMPANIES

Australia - Brazil - France - Germany - Hong Kong - Italy - Japan - Korea - Malaysia - Malta - Morocco - The Netherlands -
Singapore - Spain - Sweden - Switzerland - Taiwan - Thailand - United Kingdom - U.S.A