

8 BIT ADDRESSABLE LATCH

- HIGH SPEED
 $t_{PD} = 15 \text{ ns (TYP.) at } V_{CC} = 5 \text{ V}$
- LOW POWER DISSIPATION
 $I_{CC} = 4 \mu\text{A (MAX.) at } T_A = 25 \text{ }^\circ\text{C}$
- HIGH NOISE IMMUNITY
 $V_{NIH} = V_{NIL} = 28 \% V_{CC} \text{ (MIN.)}$
- OUTPUT DRIVE CAPABILITY
 10 LSTTL LOADS
- SYMMETRICAL PROPAGATION DELAYS
 $|I_{OH}| = I_{OL} = 4 \text{ mA (MIN.)}$
- BALANCED PRORAGATION DELAYS
 $t_{PLH} = t_{PHL}$
- WIDE OPERATING VOLTAGE RANGE
 $V_{CC} \text{ (OPR)} = 2 \text{ V to } 6 \text{ V}$
- PIN AND FUNCTION COMPATIBLE WITH
 54/74LS259

DESCRIPTION

The M54/74HC259 is a high speed CMOS 8 BIT ADDRESSABLE LATCH fabricated in silicon gate C²MOS technology. It has the same high speed performance of LSTTL combined with true CMOS low power consumption.

The M54HC259/M74HC259 has single data input (D) 8 latch outputs (Q0-Q7), 3 address inputs (A, B, and C), common enable input (E), and a common CLEAR input. To operate this device as an addressable latch, data is held on the D input, and the address of the latch into which the data is to be entered is held on the A, B, and C inputs. When $\overline{\text{ENABLE}}$ is taken low the data flows through to the addresses output. The data is stored on the positive-going edge of the $\overline{\text{ENABLE}}$ pulse. All unaddressed latches will remain unaffected. With $\overline{\text{ENABLE}}$ in the high state the device is deselected and all latches remain in their previous state, unaffected by changes on the data or address inputs. To eliminate the possibility of entering erroneous data into the latches, the $\overline{\text{ENABLE}}$ should be held high (inactive) while the address lines are changing. If $\overline{\text{ENABLE}}$ is held high and $\overline{\text{CLEAR}}$ is taken low all eight latches are cleared to the low state. If $\overline{\text{ENABLE}}$ is low all latches except the addressed latch will be cleared. The addressed latch will instead follow the D input, effectively implementing a 3-to 8 line decoder.

All inputs are equipped with protection circuits against static discharge and transient excess voltage.

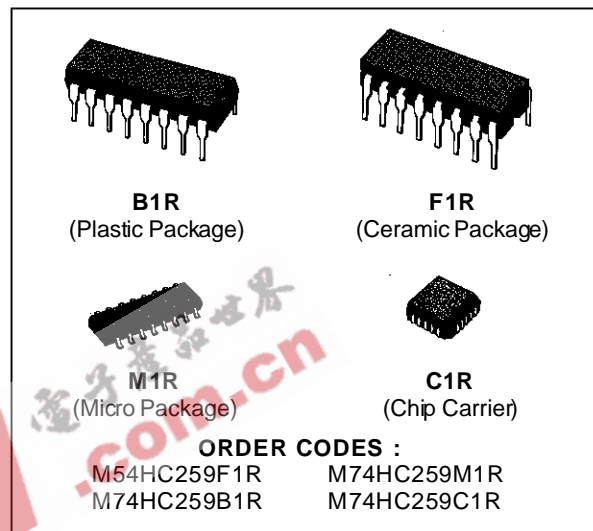

PIN CONNECTIONS (top view)

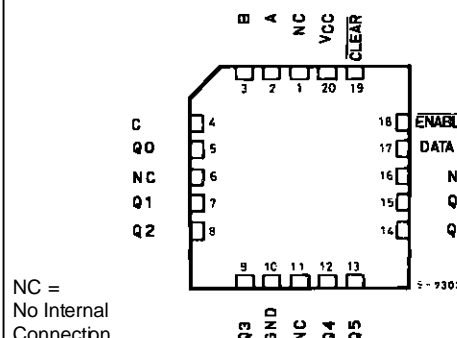
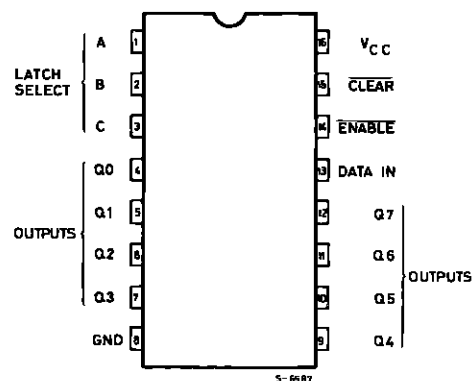

M54/M74HC259

TRUTH TABLE

INPUTS		OUTPUTS OF ADDRESSED LATCH	EACH OTHER OUTPUT	FUNCTION
CLEAR	ENABLE			
H	L	D	Qi0	ADDRESSABLE LATCH
H	H	Qi0	Qi0	MEMORY
L	L	D	L	8 LINE DEMULTIPLEXER
L	H	L	L	CLEAR ALL BITS TO 'L'

D: The level at the data input

Qi0: The level before the indicated steady state input conditions were established, (i = 0, 1,,7).

SELECT INPUTS			LATCH ADDRESSED
C	B	A	
L	L	L	Q0
L	L	H	Q1
L	H	L	Q2
L	H	H	Q3
H	L	L	Q4
H	L	H	Q5
H	H	L	Q6
H	H	H	Q7

LOGIC DIAGRAM

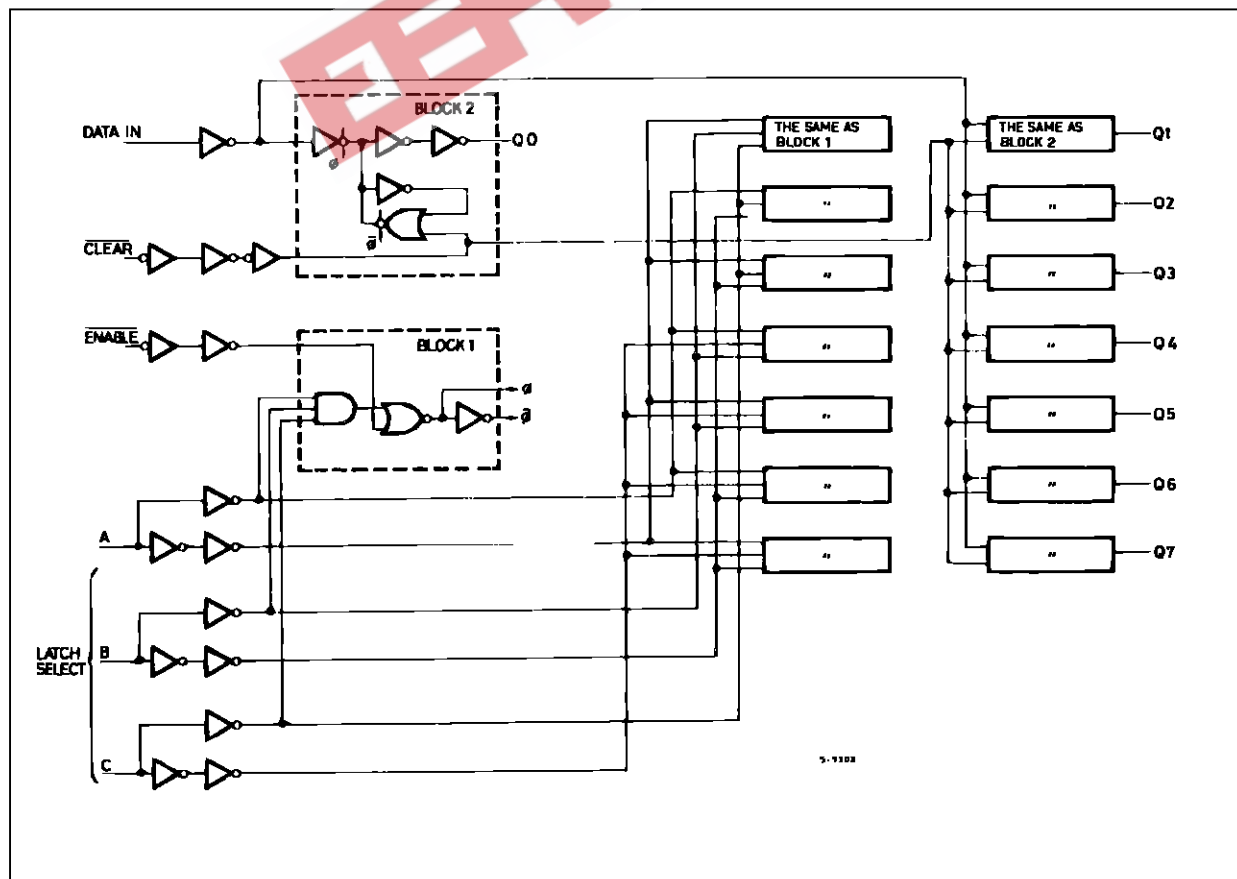

INPUT AND OUTPUT EQUIVALENT CIRCUIT

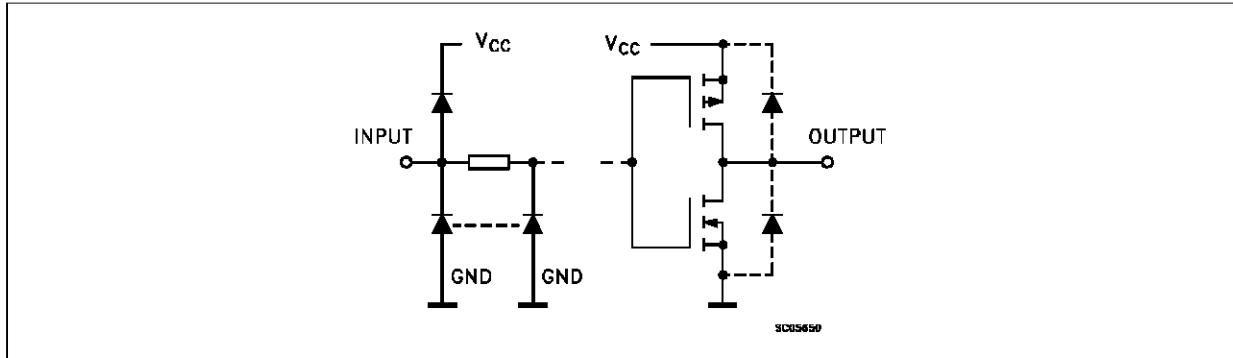

PIN DESCRIPTION

PIN No	SYMBOL	NAME AND FUNCTION
1, 2, 3	A, B, C	Address Inputs
4, 5, 6, 7, 9, 10, 11, 12	Q0 to Q7	Latch Outputs
13	D	Data Input
14	ENABLE	Latch Enable Input (Active LOW)
15	CLEAR	Conditional Reset Input (Active LOW)
8	GND	Ground (0V)
16	Vcc	Positive Supply Voltage

IEC LOGIC SYMBOL

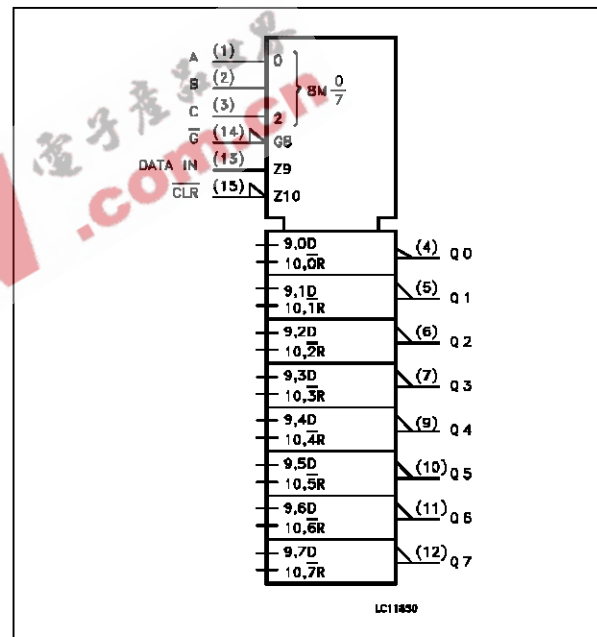

ABSOLUTE MAXIMUM RATINGS

Symbol	Parameter	Value	Unit
V _{CC}	Supply Voltage	-0.5 to +7	V
V _I	DC Input Voltage	-0.5 to V _{CC} + 0.5	V
V _O	DC Output Voltage	-0.5 to V _{CC} + 0.5	V
I _{IK}	DC Input Diode Current	± 20	mA
I _{OK}	DC Output Diode Current	± 20	mA
I _O	DC Output Source Sink Current Per Output Pin	± 25	mA
I _{CC} or I _{GND}	DC V _{CC} or Ground Current	± 50	mA
P _D	Power Dissipation	500 (*)	mW
T _{stg}	Storage Temperature	-65 to +150	°C
T _L	Lead Temperature (10 sec)	300	°C

Absolute Maximum Ratings are those values beyond which damage to the device may occur. Functional operation under these condition is not implied.
 (*) 500 mW: ≅ 65 °C derate to 300 mW by 10mW/°C: 65 °C to 85 °C

M54/M74HC259

RECOMMENDED OPERATING CONDITIONS

Symbol	Parameter	Value	Unit
V_{CC}	Supply Voltage	2 to 6	V
V_I	Input Voltage	0 to V_{CC}	V
V_O	Output Voltage	0 to V_{CC}	V
T_{op}	Operating Temperature: M54HC Series M74HC Series	-55 to +125 -40 to +85	°C °C
t_r, t_f	Input Rise and Fall Time	$V_{CC} = 2\text{ V}$	0 to 1000
		$V_{CC} = 4.5\text{ V}$	0 to 500
		$V_{CC} = 6\text{ V}$	0 to 400

DC SPECIFICATIONS

Symbol	Parameter	Test Conditions		Value						Unit	
		V_{CC} (V)		$T_A = 25\text{ °C}$ 54HC and 74HC			$-40\text{ to }85\text{ °C}$ 74HC		$-55\text{ to }125\text{ °C}$ 54HC		
				Min.	Typ.	Max.	Min.	Max.	Min.		Max.
V_{IH}	High Level Input Voltage	2.0		1.5			1.5		1.5	V	
		4.5		3.15			3.15		3.15		
		6.0		4.2			4.2		4.2		
V_{IL}	Low Level Input Voltage	2.0				0.5		0.5	0.5	V	
		4.5				1.35		1.35	1.35		
		6.0				1.8		1.8	1.8		
V_{OH}	High Level Output Voltage	2.0	$V_I = V_{IH}$ or V_{IL}	$I_O = -20\text{ }\mu\text{A}$	1.9	2.0		1.9		1.9	V
		4.5			4.4	4.5		4.4		4.4	
		6.0			5.9	6.0		5.9		5.9	
		4.5			4.18	4.31		4.13		4.10	
		6.0			5.68	5.8		5.63		5.60	
V_{OL}	Low Level Output Voltage	2.0	$V_I = V_{IH}$ or V_{IL}	$I_O = 20\text{ }\mu\text{A}$		0.0	0.1		0.1	0.1	V
		4.5				0.0	0.1		0.1	0.1	
		6.0				0.0	0.1		0.1	0.1	
		4.5				0.17	0.26		0.33	0.40	
		6.0				0.18	0.26		0.33	0.40	
I_I	Input Leakage Current	6.0	$V_I = V_{CC}$ or GND			± 0.1		± 1	± 1	μA	
I_{CC}	Quiescent Supply Current	6.0	$V_I = V_{CC}$ or GND			4		40	80	μA	

AC ELECTRICAL CHARACTERISTICS (C_L = 50 pF, Input t_r = t_f = 6 ns)

Symbol	Parameter	Test Conditions		Value						Unit	
		V _{CC} (V)		T _A = 25 °C 54HC and 74HC			-40 to 85 °C 74HC		-55 to 125 °C 54HC		
				Min.	Typ.	Max.	Min.	Max.	Min.		Max.
t _{TLH} t _{THL}	Output Transition Time	2.0			30	75		95		110	ns
		4.5			8	15		19		22	
		6.0			7	13		16		19	
t _{PLH} t _{PHL}	Propagation Delay Time (DATA - Q)	2.0			56	140		175		210	ns
		4.5			18	28		35		42	
		6.0			15	24		30		36	
t _{PLH} t _{PHL}	Propagation Delay Time (A, B, C - Q)	2.0			76	190		240		285	ns
		4.5			24	38		48		57	
		6.0			20	32		41		48	
t _{PLH} t _{PHL}	Propagation Delay Time (G - Q)	2.0			57	150		190		225	ns
		4.5			19	30		38		45	
		6.0			16	26		32		38	
t _{PLH} t _{PHL}	Propagation Delay Time (CLEAR - Q)	2.0			45	115		145		175	ns
		4.5			15	23		29		35	
		6.0			13	20		25		30	
t _{w(L)}	Minimum Pulse Width (ENABLE)	2.0			28	75		90		115	ns
		4.5			7	15		19		23	
		6.0			6	13		16		20	
t _{w(L)}	Minimum Pulse Width (CLEAR)	2.0			24	75		90		115	ns
		4.5			6	15		19		23	
		6.0			5	13		16		20	
t _s	Minimum Set-up Time (DATA)	2.0			12	50		60		75	ns
		4.5			3	10		12		15	
		6.0			3	9		11		13	
t _s	Minimum Set-up Time (A, B, C)	2.0				25		30		40	ns
		4.5				5		6		8	
		6.0				5		5		7	
t _h	Minimum Hold Time (DATA)	2.0				5		5		5	ns
		4.5				5		5		5	
		6.0				5		5		5	
t _h	Minimum Hold Time (A, B, C)	2.0				0		0		0	ns
		4.5				0		0		0	
		6.0					0		0		
C _{IN}	Input Capacitance				5	10		10		10	pF
C _{PD} (*)	Power Dissipation Capacitance				66						pF

(*) C_{PD} is defined as the value of the IC's internal equivalent capacitance which is calculated from the operating current consumption without load. (Refer to Test Circuit). Average operating current can be obtained by the following equation. I_{CC(OPR)} = C_{PD} • V_{CC} • f_{IN} + I_{CC}

SWITCHING CHARACTERISTICS TEST WAVEFORM

WAVEFORM 1. ($\overline{\text{ENABLE}} = \text{L}$, $\overline{\text{CLR}} = \text{H}$, A ~ C =

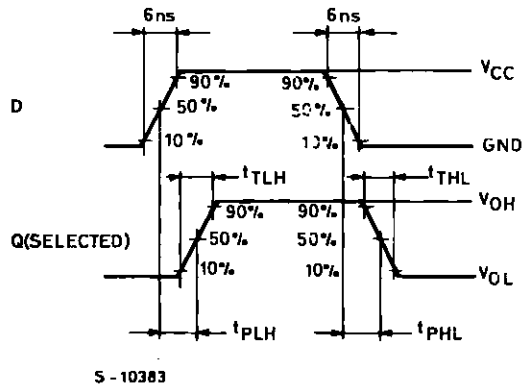

WAVEFORM 2. ($\overline{\text{G}} = \text{L}$)

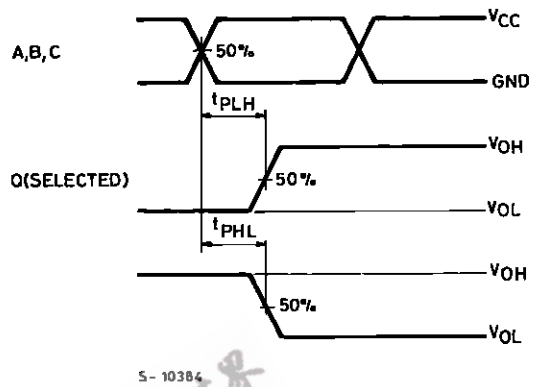

WAVEFORM 3. ($\overline{\text{CLR}} = \text{H}$, A ~ C = Stable)

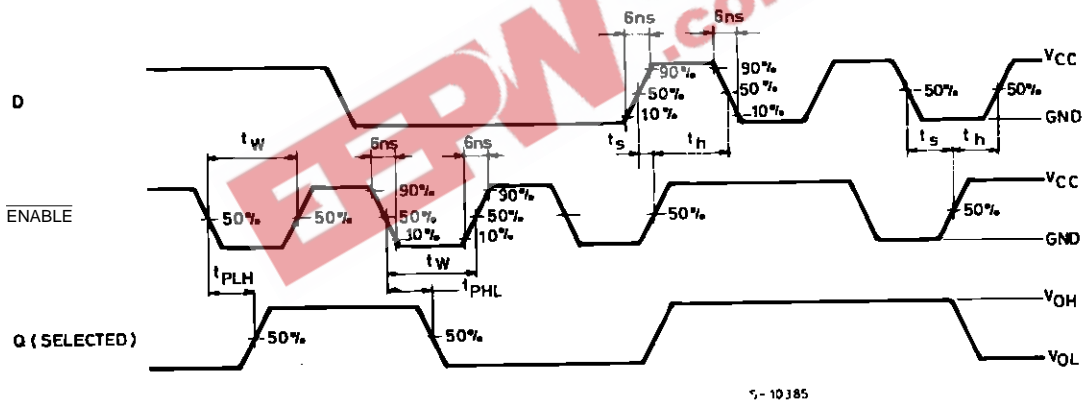

WAVEFORM 4. (D = H, A ~ C = Stable)

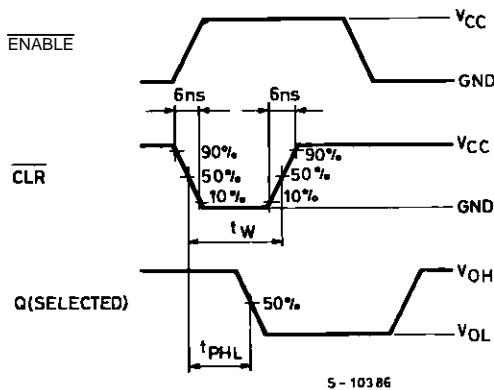

WAVEFORM 5. ($\overline{\text{CLR}} = \text{H}$)

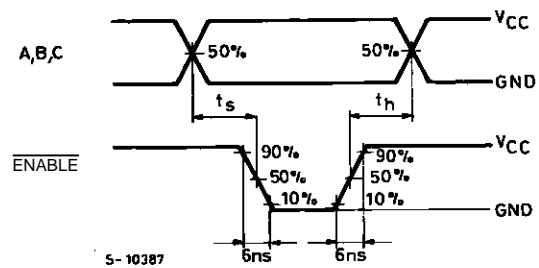

TEST CIRCUIT I_{CC} (Opr.)

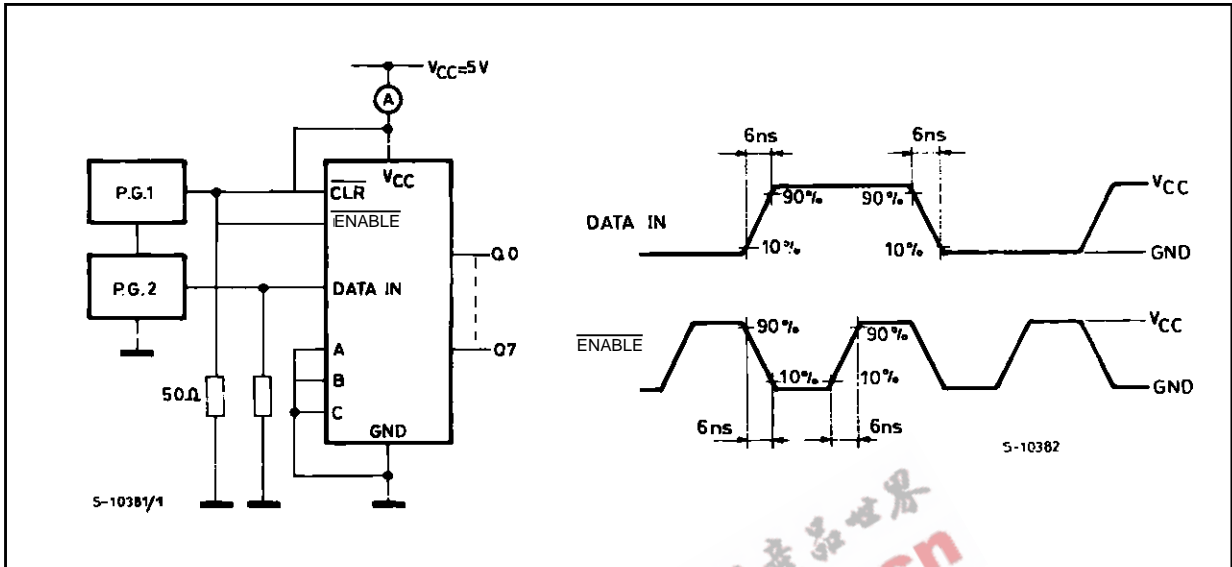

EEPW.com.cn 电子产品世界

M54/M74HC259

Plastic DIP16 (0.25) MECHANICAL DATA

DIM.	mm			inch		
	MIN.	TYP.	MAX.	MIN.	TYP.	MAX.
a1	0.51			0.020		
B	0.77		1.65	0.030		0.065
b		0.5			0.020	
b1		0.25			0.010	
D			20			0.787
E		8.5			0.335	
e		2.54			0.100	
e3		17.78			0.700	
F			7.1			0.280
I			5.1			0.201
L		3.3			0.130	
Z			1.27			0.050

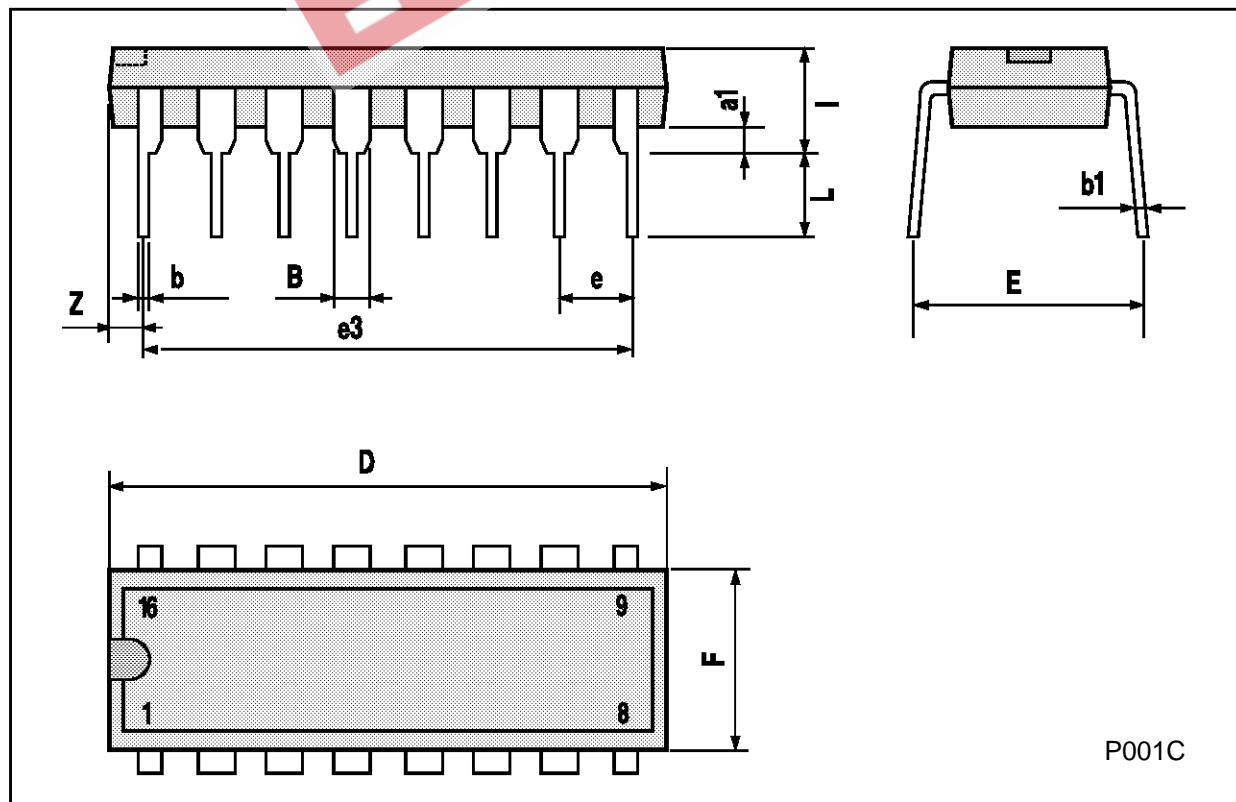

P001C

Ceramic DIP16/1 MECHANICAL DATA

DIM.	mm			inch		
	MIN.	TYP.	MAX.	MIN.	TYP.	MAX.
A			20			0.787
B			7			0.276
D		3.3			0.130	
E	0.38			0.015		
e3		17.78			0.700	
F	2.29		2.79	0.090		0.110
G	0.4		0.55	0.016		0.022
H	1.17		1.52	0.046		0.060
L	0.22		0.31	0.009		0.012
M	0.51		1.27	0.020		0.050
N			10.3			0.406
P	7.8		8.05	0.307		0.317
Q			5.08			0.200

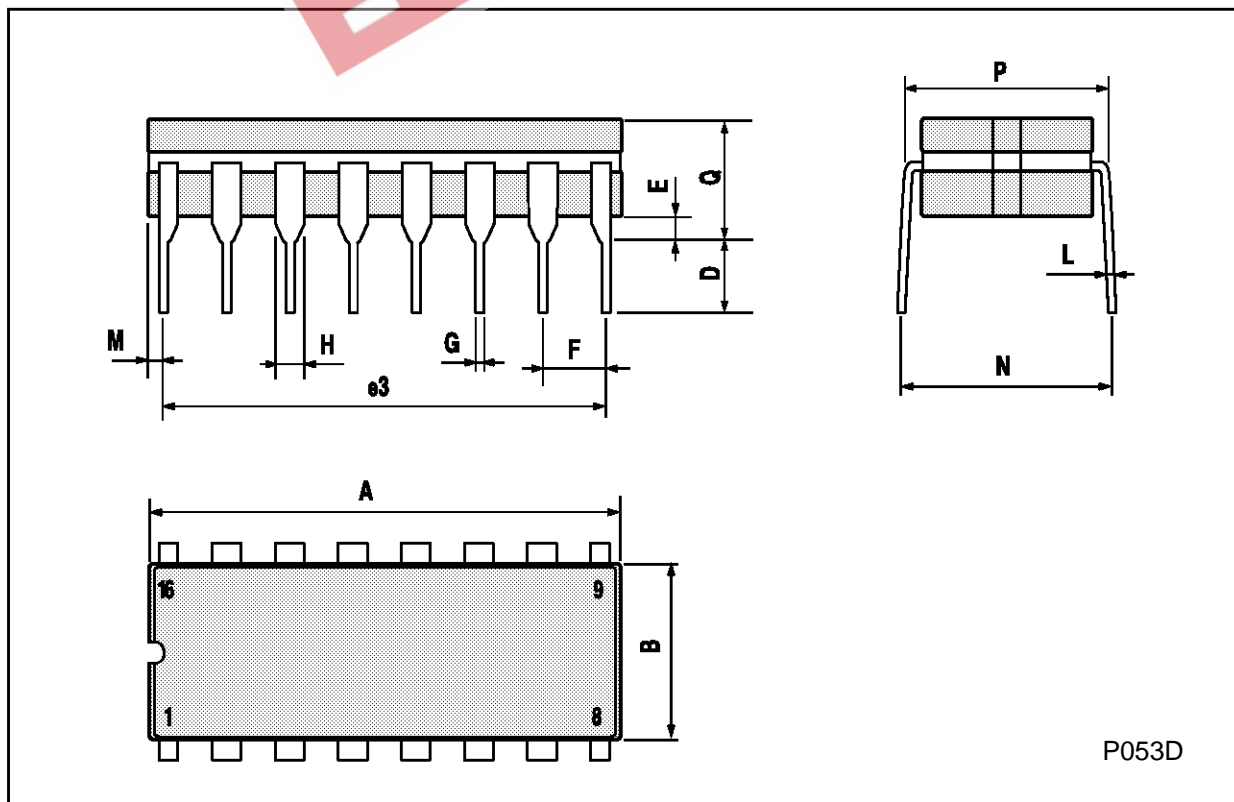

SO16 (Narrow) MECHANICAL DATA

DIM.	mm			inch		
	MIN.	TYP.	MAX.	MIN.	TYP.	MAX.
A			1.75			0.068
a1	0.1		0.2	0.004		0.007
a2			1.65			0.064
b	0.35		0.46	0.013		0.018
b1	0.19		0.25	0.007		0.010
C		0.5			0.019	
c1	45° (typ.)					
D	9.8		10	0.385		0.393
E	5.8		6.2	0.228		0.244
e		1.27			0.050	
e3		8.89			0.350	
F	3.8		4.0	0.149		0.157
G	4.6		5.3	0.181		0.208
L	0.5		1.27	0.019		0.050
M			0.62			0.024
S	8° (max.)					

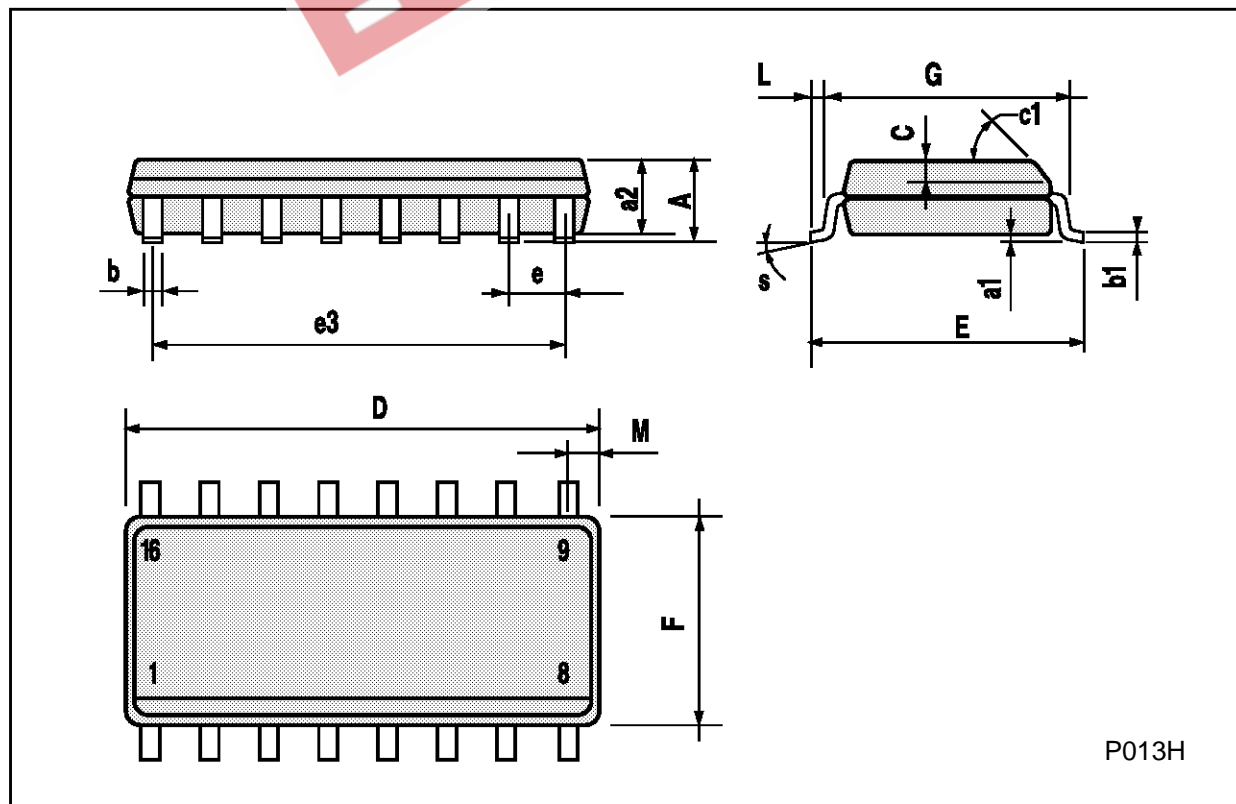

PLCC20 MECHANICAL DATA

DIM.	mm			inch		
	MIN.	TYP.	MAX.	MIN.	TYP.	MAX.
A	9.78		10.03	0.385		0.395
B	8.89		9.04	0.350		0.356
D	4.2		4.57	0.165		0.180
d1		2.54			0.100	
d2		0.56			0.022	
E	7.37		8.38	0.290		0.330
e		1.27			0.050	
e3		5.08			0.200	
F		0.38			0.015	
G			0.101			0.004
M		1.27			0.050	
M1		1.14			0.045	

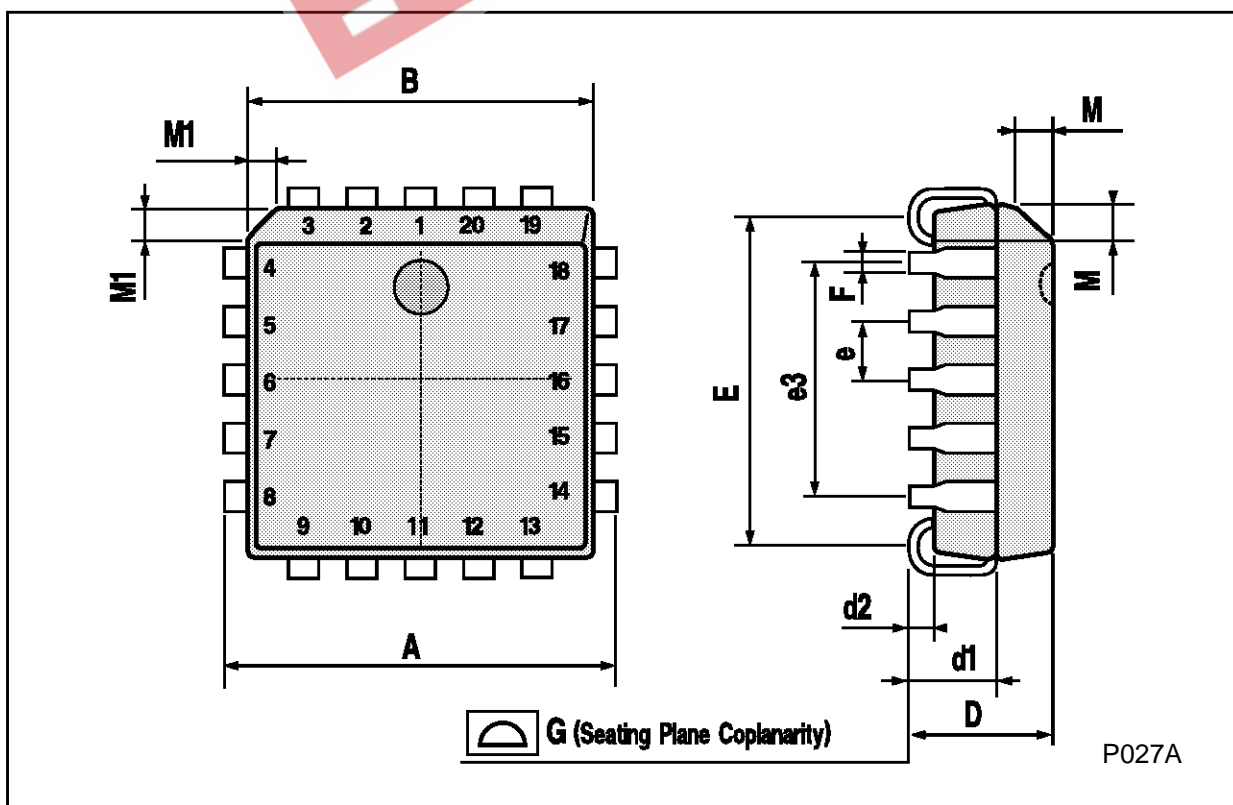

EEPW 电子產品世界
.com.cn

Information furnished is believed to be accurate and reliable. However, SGS-THOMSON Microelectronics assumes no responsibility for the consequences of use of such information nor for any infringement of patents or other rights of third parties which may result from its use. No license is granted by implication or otherwise under any patent or patent rights of SGS-THOMSON Microelectronics. Specifications mentioned in this publication are subject to change without notice. This publication supersedes and replaces all information previously supplied. SGS-THOMSON Microelectronics products are not authorized for use as critical components in life support devices or systems without express written approval of SGS-THOMSON Microelectronics.

© 1994 SGS-THOMSON Microelectronics - All Rights Reserved

SGS-THOMSON Microelectronics GROUP OF COMPANIES
Australia - Brazil - France - Germany - Hong Kong - Italy - Japan - Korea - Malaysia - Malta - Morocco - The Netherlands -
Singapore - Spain - Sweden - Switzerland - Taiwan - Thailand - United Kingdom - U.S.A