

## 8 STAGE PRESETTABLE SYNCHRONOUS DOWN COUNTERS

- HIGH SPEED  
 $f_{MAX} = 40 \text{ MHz (TYP.) at } V_{CC} = 5 \text{ V}$
- LOW POWER DISSIPATION  
 $I_{CC} = 4 \mu\text{A (MAX.) at } T_A = 25 \text{ }^\circ\text{C}$
- HIGH NOISE IMMUNITY  
 $V_{NIH} = V_{NIL} = 28 \% V_{CC} \text{ (MIN.)}$
- OUTPUT DRIVE CAPABILITY  
 10 LSTTL LOADS
- SYMMETRICAL OUTPUT IMPEDANCE  
 $|I_{OH}| = |I_{OL}| = 4 \text{ mA (MIN.)}$
- BALANCED PROPAGATION DELAYS  
 $t_{PLH} = t_{PHL}$
- WIDE OPERATING VOLTAGE RANGE  
 $V_{CC} \text{ (OPR)} = 2 \text{ V to } 6 \text{ V}$
- PIN AND FUNCTION COMPATIBLE WITH  
 40102B/40103B

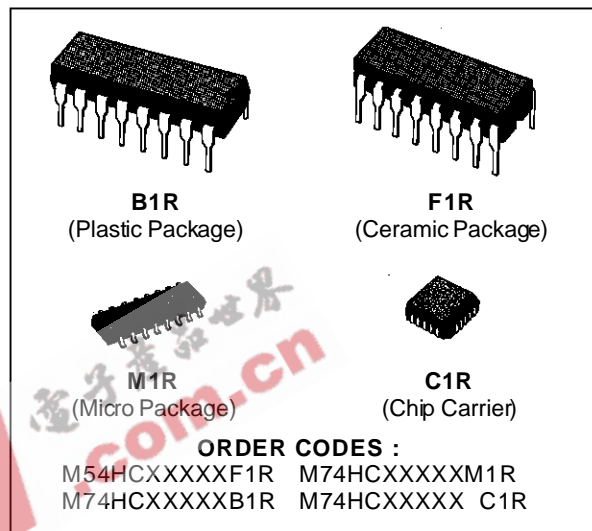

### DESCRIPTION

The M54/74HC40102/40103 are high speed CMOS 8-STAGE PRESETTABLE SYNCHRONOUS DOWN COUNTERS fabricated with silicon gate C<sup>2</sup>MOS technology. They achieve the high speed operation similar to equivalent LSTTL while maintaining the CMOS low power dissipation.

The HC40102, and HC40103 consist of an 8-stage synchronous down counter with a single output which is active when the internal count is zero. The HC40102 is configured as two cascaded 4-bit BCD counters, and the HC40103 contains a single 8-bit binary counter. Each type has control inputs for enabling or disabling the clock, for clearing the counter to its maximum count, and for presetting the counter either synchronously or asynchronously. All control inputs and the CARRY-OUT/ZERO-DETECT output are active-low logic. In normal operation, the counter is decremented by one count on each positive transition of the CLOCK. Counting is inhibited when the CARRY-IN/COUNTER ENABLE (CI/CE) input is high. The CARRY-OUT/ZERO-DETECT (CO/ZD) output goes low when the count reaches zero if the CI/CE input is low, and remains low for one full clock period. When the SYNCHRONOUS PRESET-ENABLE (SPE) input is low, data at the J input is clocked into the counter on the next positive clock transition regardless of the state of the CI/CE input.

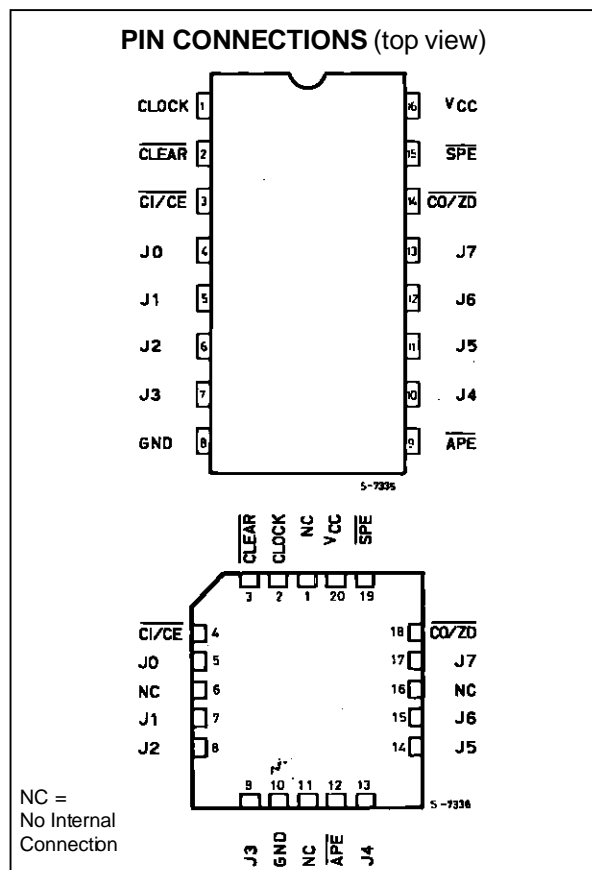

## M54/M74HC40102/40103

### DESCRIPTION (Continued)

When the ASYNCHRONOUS PRESET-ENABLE (APE) input is low, data at the J inputs is asynchronously forced into the counter regardless of the state of the  $\overline{\text{SPE}}$ ,  $\overline{\text{CI/CE}}$ , or CLOCK inputs. J Inputs J0-J7 represent two 4-bit BCD words for the HC40102 and a single 8-bit binary word for the HC40103. When the CLEAR ( $\overline{\text{CLR}}$ ) input is low, the counter is asynchronously cleared to its maximum count (99<sub>10</sub> for the HC40102 and 255<sub>10</sub> for the HC40103 regardless of the state of any other input. The precedence

relationship between control input is indicated in the truth table. If all control inputs are high at the time of zero count, the counters will jump to the maximum count, giving a counting sequence of 100 or 256 clock pulses long. The HC40102 and HC40103 may be cascaded using the  $\overline{\text{CI/CE}}$  input and the  $\overline{\text{CO/ZD}}$  output, in either a synchronous or ripple mode. All inputs are equipped with protection circuits against static discharge and transient excess voltage.

### TRUTH TABLE

CONTROL INPUTS				MODE	FUNCTIONAL DESCRIPTION
CLEAR	APE	SPE	CI/CE		
H	H	H	H	COUNT INHIBIT	EVEN IF CLOCK IS GIVEN, NO COUNT IS MADE
H	H	H	L	REGULAR COUNT	DOWN COUNT AT RISING EDGE OF CLOCK
H	H	L	X	SYNCHRONOUS PRESET	DATA OF PI TERMINAL IS PRESET AT RISING EDGE OF CLOCK
H	L	X	X	ASYNCHRONOUS PRESET	DATA OF PI TERMINAL IS ASYNCHRONOUSLY PRESET TO CLOCK
L	X	X	X	CLEAR	COUNTER IS SET TO MAXIMUM COUNT

X: DON'T CARE - MAXIMUM COUNT: "99" FOR HC40102 AND "255": FOR HC40103

### LOGIC DIAGRAM (HC40102)

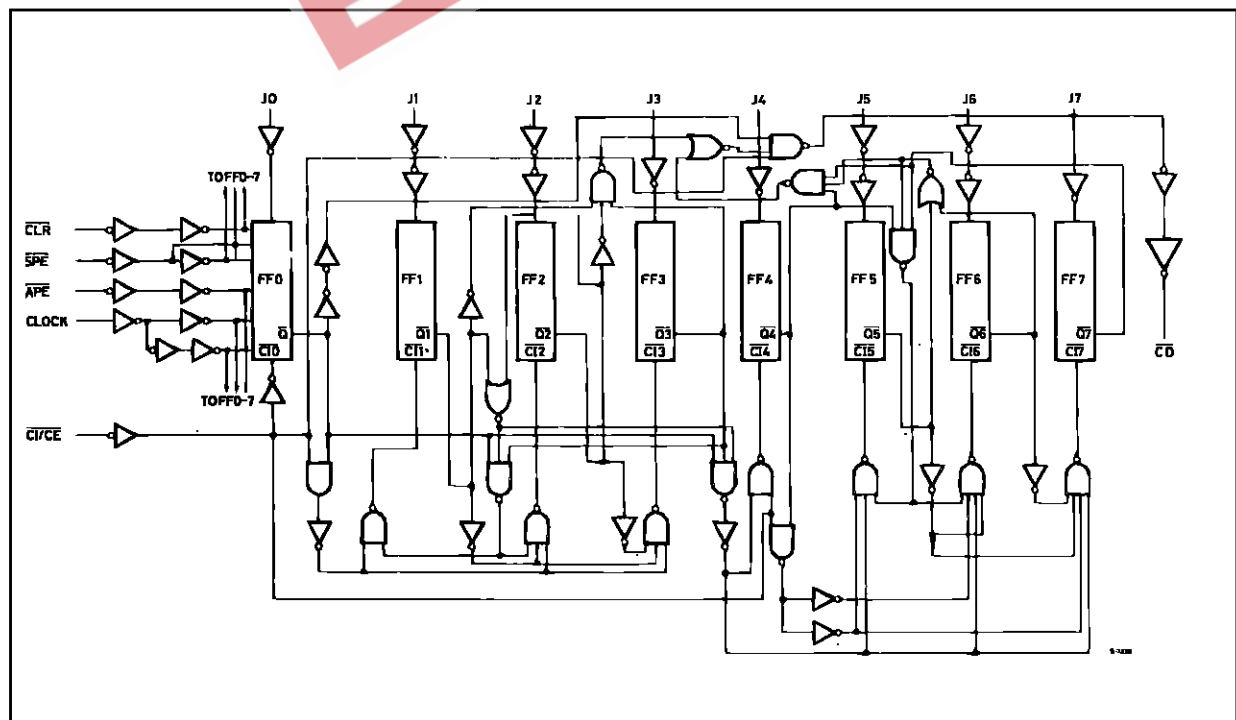

LOGIC DIAGRAM (HC40103)

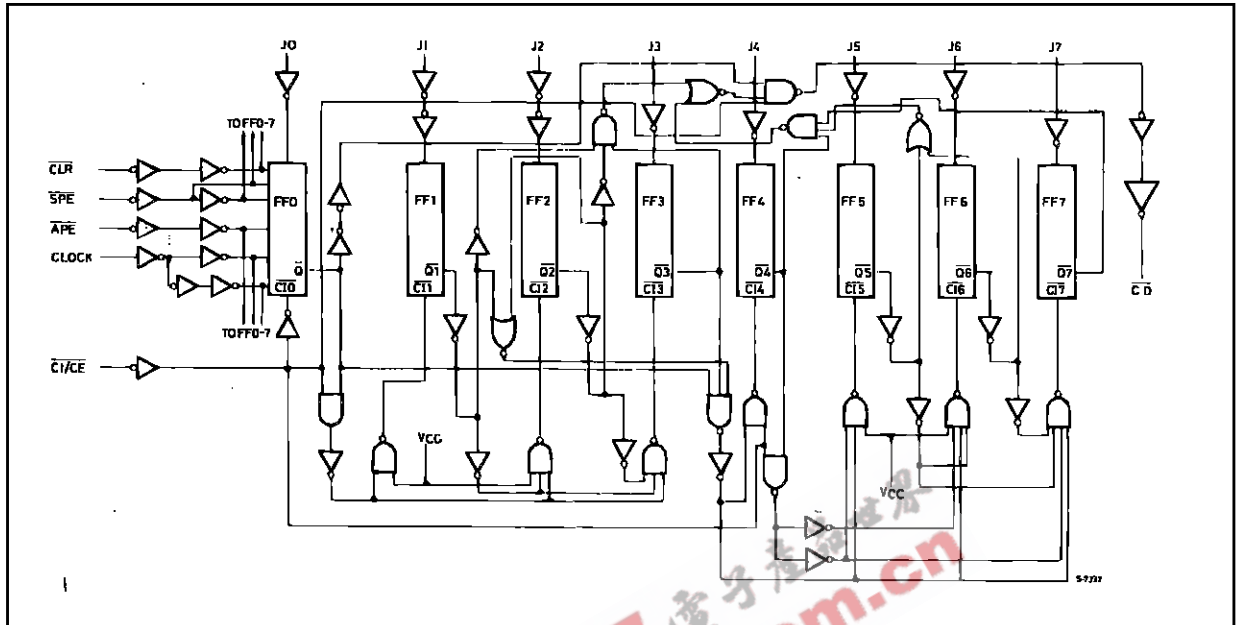

TIMING CHART

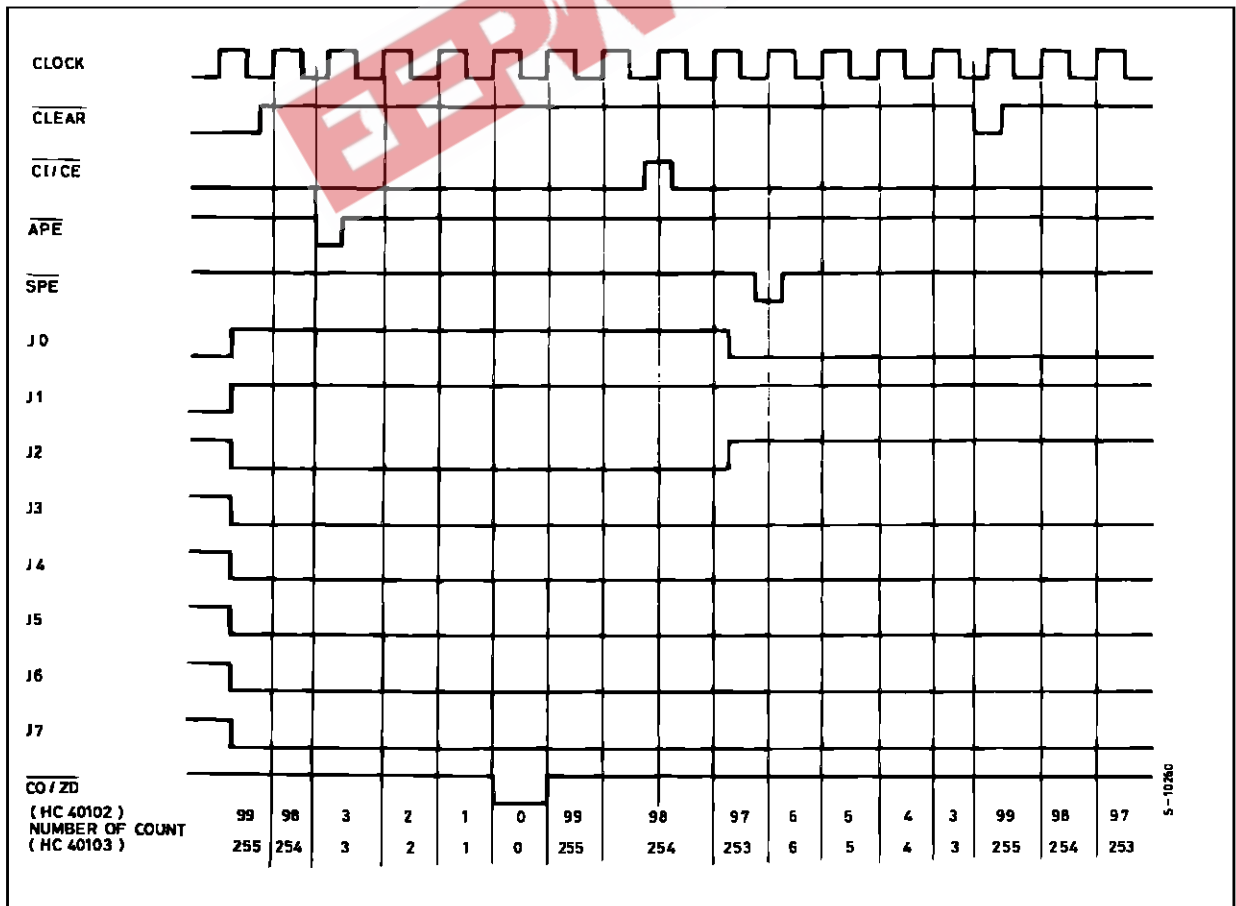

## M54/M74HC40102/40103

### PIN DESCRIPTION

PIN No	SYMBOL	NAME AND FUNCTION
1	CLOCK	CLock Input (LOW to HIGH edge triggered)
2	$\overline{\text{CLEAR}}$	Asynchronous Master Reset Input (Active LOW)
3	$\overline{\text{CI/CE}}$	Terminal Enable Input
4, 5, 6, 7, 10, 11, 12, 13	J0 to J9	Jam Inputs
9	$\overline{\text{APE}}$	Asynchronous Preset Enable Input (Active LOW)
14	$\overline{\text{CO/ZD}}$	Terminal Count Output (Active LOW)
15	$\overline{\text{SPE}}$	Synchronous Preset Enable Input (Active LOW)
8	GND	Ground (0V)
16	V <sub>CC</sub>	Positive Supply Voltage

### INPUT AND OUTPUT EQUIVALENT CIRCUIT

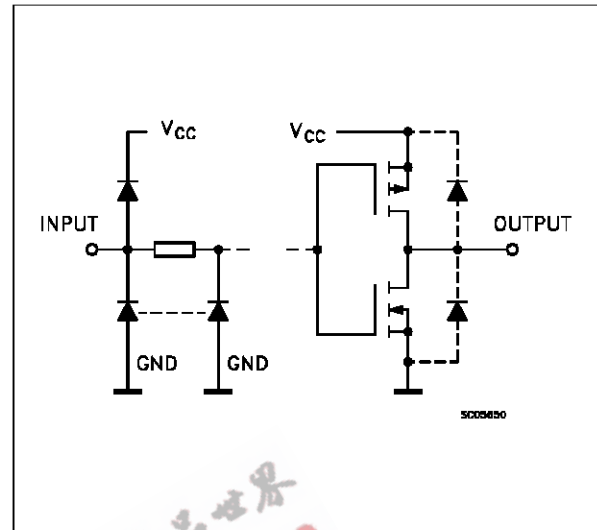

### IEC LOGIC SYMBOLS

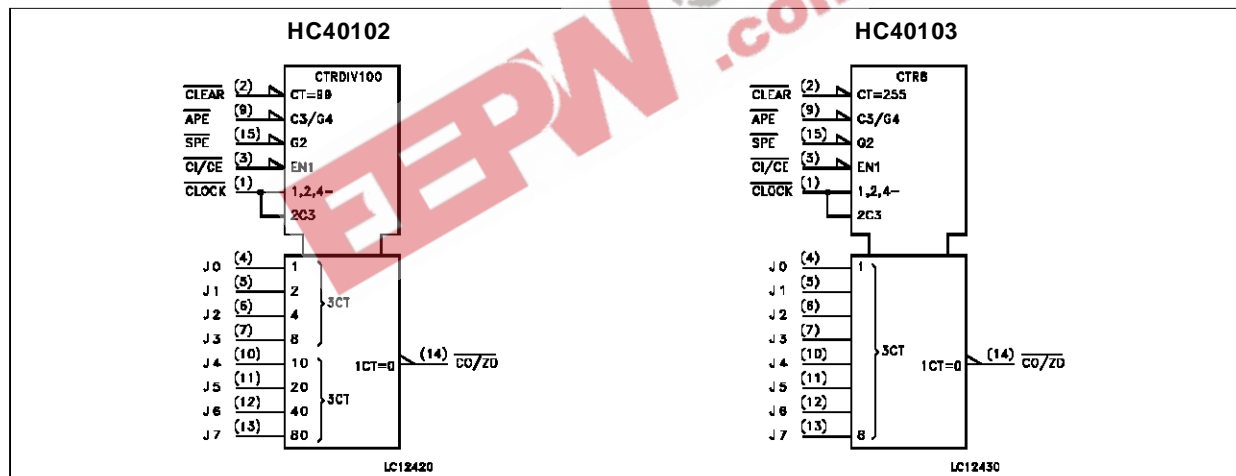

### ABSOLUTE MAXIMUM RATINGS

Symbol	Parameter	Value	Unit
V <sub>CC</sub>	Supply Voltage	-0.5 to +7	V
V <sub>I</sub>	DC Input Voltage	-0.5 to V <sub>CC</sub> + 0.5	V
V <sub>O</sub>	DC Output Voltage	-0.5 to V <sub>CC</sub> + 0.5	V
I <sub>IK</sub>	DC Input Diode Current	± 20	mA
I <sub>OK</sub>	DC Output Diode Current	± 20	mA
I <sub>O</sub>	DC Output Source Sink Current Per Output Pin	± 25	mA
I <sub>CC</sub> or I <sub>GND</sub>	DC V <sub>CC</sub> or Ground Current	± 50	mA
P <sub>D</sub>	Power Dissipation	500 (*)	mW
T <sub>stg</sub>	Storage Temperature	-65 to +150	°C
T <sub>L</sub>	Lead Temperature (10 sec)	300	°C

Absolute Maximum Ratings are those values beyond which damage to the device may occur. Functional operation under these condition is not implied.

(\*) 500 mW: ≅ 65 °C derate to 300 mW by 10mW/°C: 65 °C to 85 °C

## RECOMMENDED OPERATING CONDITIONS

Symbol	Parameter	Value	Unit
V <sub>CC</sub>	Supply Voltage	2 to 6	V
V <sub>I</sub>	Input Voltage	0 to V <sub>CC</sub>	V
V <sub>O</sub>	Output Voltage	0 to V <sub>CC</sub>	V
T <sub>op</sub>	Operating Temperature: <b>M54HC Series</b> <b>M74HC Series</b>	-55 to +125 -40 to +85	°C °C
t <sub>r</sub> , t <sub>f</sub>	Input Rise and Fall Time	V <sub>CC</sub> = 2 V 0 to 1000 V <sub>CC</sub> = 4.5 V 0 to 500 V <sub>CC</sub> = 6 V 0 to 400	ns

## DC SPECIFICATIONS

Symbol	Parameter	Test Conditions		Value						Unit	
		V <sub>CC</sub> (V)		T <sub>A</sub> = 25 °C 54HC and 74HC			-40 to 85 °C 74HC		-55 to 125 °C 54HC		
				Min.	Typ.	Max.	Min.	Max.	Min.		Max.
V <sub>IH</sub>	High Level Input Voltage	2.0		1.5			1.5		1.5	V	
		4.5		3.15			3.15		3.15		
		6.0		4.2			4.2		4.2		
V <sub>IL</sub>	Low Level Input Voltage	2.0				0.5		0.5	0.5	V	
		4.5				1.35		1.35	1.35		
		6.0				1.8		1.8	1.8		
V <sub>OH</sub>	High Level Output Voltage	2.0	V <sub>I</sub> = V <sub>IH</sub> or V <sub>IL</sub> I <sub>O</sub> = -20 μA	1.9	2.0		1.9		1.9	V	
		4.5		4.4	4.5		4.4		4.4		
		6.0		5.9	6.0		5.9		5.9		
		4.5		4.18	4.31		4.13		4.10		
		6.0		5.68	5.8		5.63		5.60		
V <sub>OL</sub>	Low Level Output Voltage	2.0	V <sub>I</sub> = V <sub>IH</sub> or V <sub>IL</sub> I <sub>O</sub> = 20 μA		0.0	0.1		0.1	0.1	V	
		4.5			0.0	0.1		0.1	0.1		
		6.0			0.0	0.1		0.1	0.1		
		4.5			0.17	0.26		0.33	0.40		
		6.0			0.18	0.26		0.33	0.40		
I <sub>I</sub>	Input Leakage Current	6.0	V <sub>I</sub> = V <sub>CC</sub> or GND			±0.1		±1	±1	μA	
I <sub>CC</sub>	Quiescent Supply Current	6.0	V <sub>I</sub> = V <sub>CC</sub> or GND			4		40	80	μA	

## M54/M74HC40102/40103

### AC ELECTRICAL CHARACTERISTICS ( $C_L = 50 \text{ pF}$ , Input $t_r = t_f = 6 \text{ ns}$ )

Symbol	Parameter	Test Conditions		Value						Unit	
		$V_{CC}$ (V)		$T_A = 25 \text{ }^\circ\text{C}$ 54HC and 74HC			$-40 \text{ to } 85 \text{ }^\circ\text{C}$ 74HC		$-55 \text{ to } 125 \text{ }^\circ\text{C}$ 54HC		
				Min.	Typ.	Max.	Min.	Max.	Min.		Max.
$t_{TLH}$ $t_{THL}$	Output Transition Time	2.0			30	75		95		110	ns
		4.5			8	15		19		22	
		6.0			7	13		16		19	
$t_{PLH}$ $t_{PHL}$	Propagation Delay Time (CK - CO/ZD)	2.0			96	185		230		280	ns
		4.5			24	37		46		56	
		6.0			20	31		39		47	
$t_{PLH}$ $t_{PHL}$	Propagation Delay Time (APE - CO/ZD)	2.0			116	225		280		340	ns
		4.5			29	45		56		68	
		6.0			25	38		48		57	
$t_{PLH}$ $t_{PHL}$	Propagation Delay Time (CL - CO/ZD)	2.0			104	200		250		300	ns
		4.5			26	40		50		60	
		6.0			22	34		43		51	
$t_{PLH}$ $t_{PHL}$	Propagation Delay Time (CI/CE - CO/ZD)	2.0			48	95		120		145	ns
		4.5			12	19		24		29	
		6.0			10	16		20		24	
$f_{MAX}$	Propagation Delay Time	2.0			4	8		3		2.6	pF
		4.5			20	32		16		13	
		6.0			24	38		19		15	
$C_{IN}$	Input Capacitance				5	10		10		10	pF
$C_{PD} (*)$	Power Dissipation Capacitance				60						pF

(\*)  $C_{PD}$  is defined as the value of the IC's internal equivalent capacitance which is calculated from the operating current consumption without load. (Refer to Test Circuit). Average operating current can be obtained by the following equation.  $I_{CC(opr)} = C_{PD} \cdot V_{CC} \cdot f_{IN} + I_{CC}$

### TEST CIRCUIT $I_{CC}$ (Opr.)

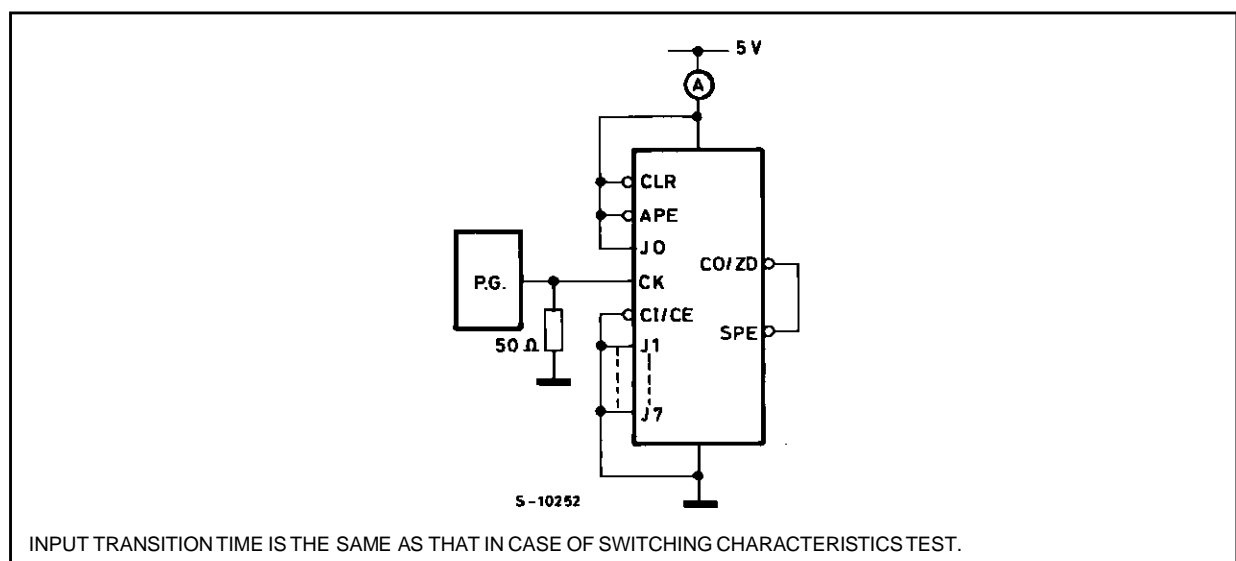

INPUT TRANSITION TIME IS THE SAME AS THAT IN CASE OF SWITCHING CHARACTERISTICS TEST.



SWITCHING CHARACTERISTICS TEST WAVEFORM

WAVEFORM 1

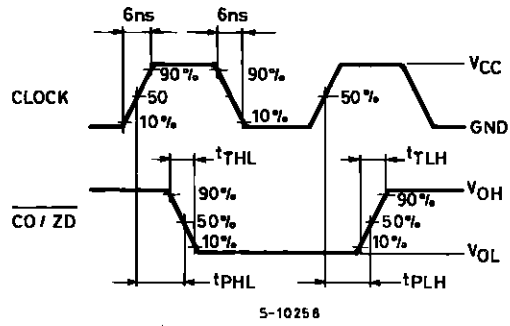

WAVEFORM 2

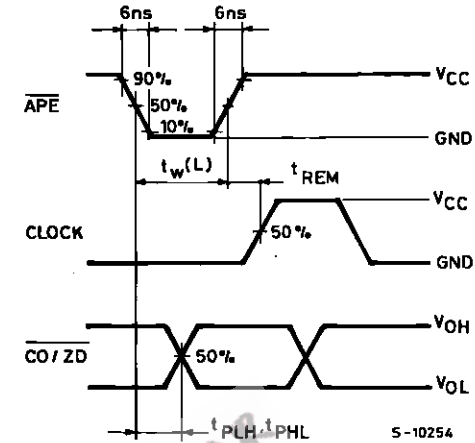

WAVEFORM 3

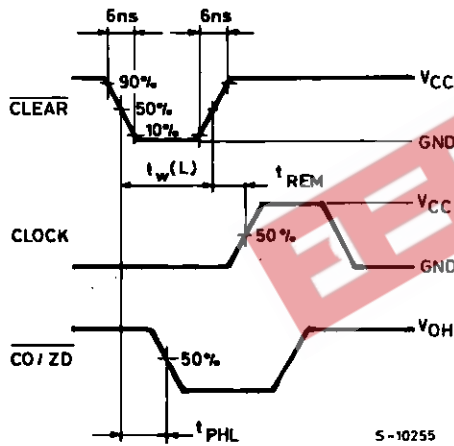

WAVEFORM 4

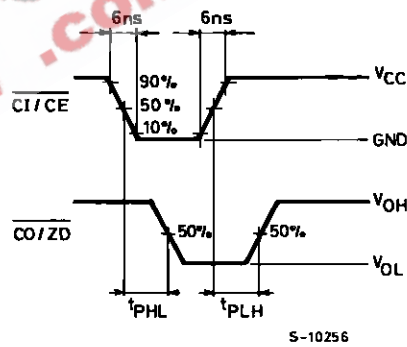

WAVEFORM 5

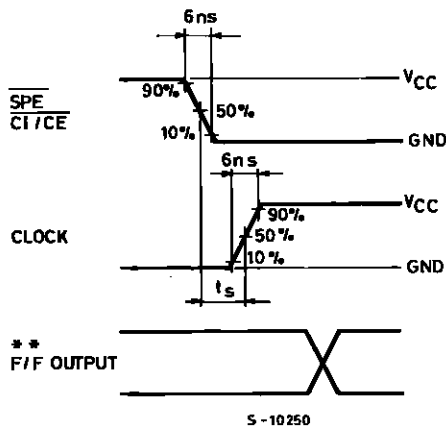

WAVEFORM 6

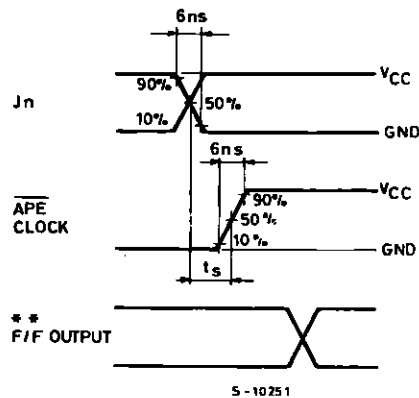

(\*\* F/F output is internal signal of IC)



EXAMPLE OF TYPICAL APPLICATION

PROGRAMMABLE DIVIDE-BY-N COUNTER

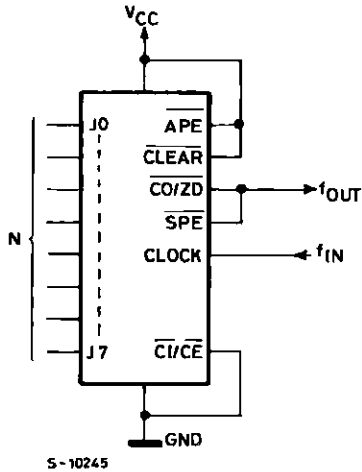

- $f_{OUT} = \frac{f_{IN}}{N+1}$
- Timing chart when N = "3"  
(J0, J1 = V<sub>CC</sub>, J2 - J7 = GND)

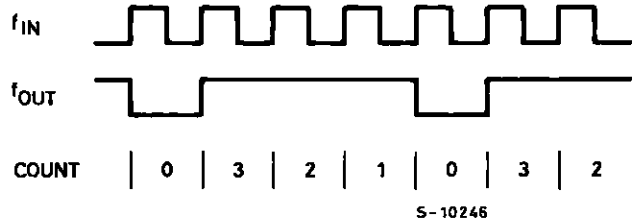

- HC40102... 1/2 to 1/100 are dividable
- HC40103... 1/2 to 1/256 are dividable

PARALLEL CARRY CASCADING

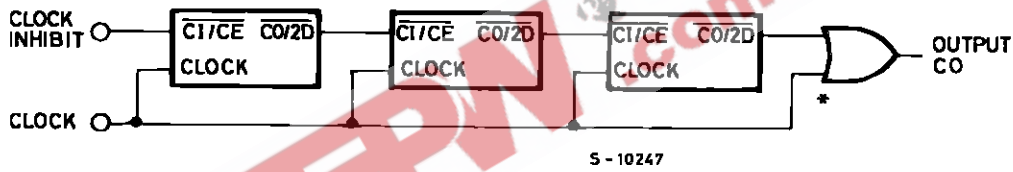

\* At synchronous cascade connection, huzzerd occurs at CO output after its second stage when digit place changes, due to delay arrival. Therefore, take gate from HC32 or the like, not from CO output at the rear stage directly.

PROGRAMMABLE TIMER

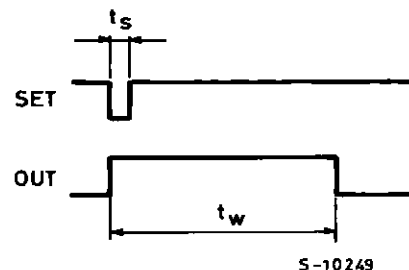
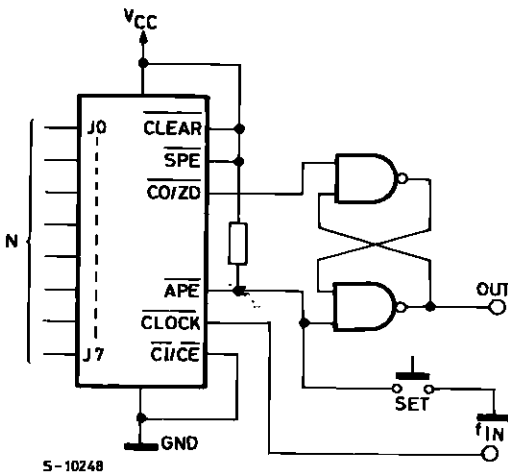

$$t_w = \left( \frac{N}{f_{IN}} + t_s \right)$$

Note :The above formula does not take into account the phase of clock input. Therefore, the real pulse width is the distance between the above formula-1/f<sub>IN</sub> - the above formula.

**Plastic DIP16 (0.25) MECHANICAL DATA**

DIM.	mm			inch		
	MIN.	TYP.	MAX.	MIN.	TYP.	MAX.
a1	0.51			0.020		
B	0.77		1.65	0.030		0.065
b		0.5			0.020	
b1		0.25			0.010	
D			20			0.787
E		8.5			0.335	
e		2.54			0.100	
e3		17.78			0.700	
F			7.1			0.280
I			5.1			0.201
L		3.3			0.130	
Z			1.27			0.050

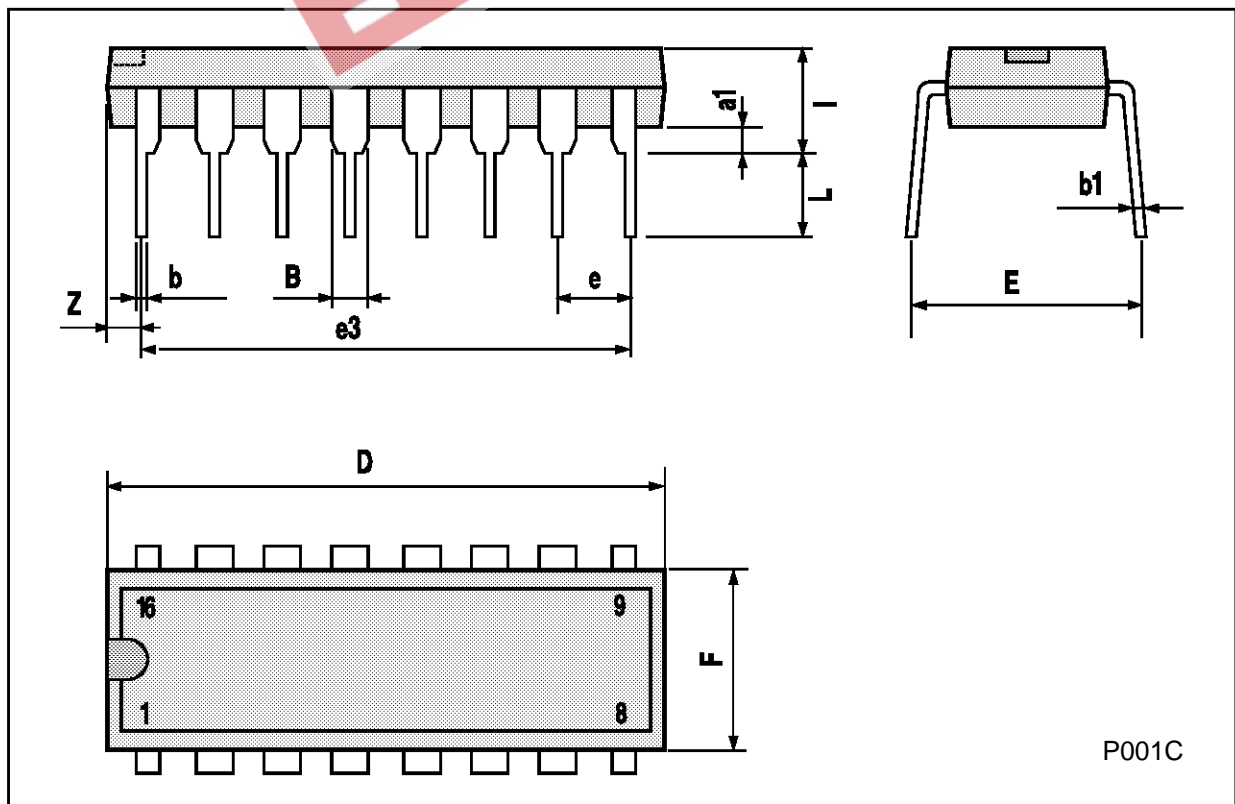

## Ceramic DIP16/1 MECHANICAL DATA

DIM.	mm			inch		
	MIN.	TYP.	MAX.	MIN.	TYP.	MAX.
A			20			0.787
B			7			0.276
D		3.3			0.130	
E	0.38			0.015		
e3		17.78			0.700	
F	2.29		2.79	0.090		0.110
G	0.4		0.55	0.016		0.022
H	1.17		1.52	0.046		0.060
L	0.22		0.31	0.009		0.012
M	0.51		1.27	0.020		0.050
N			10.3			0.406
P	7.8		8.05	0.307		0.317
Q			5.08			0.200

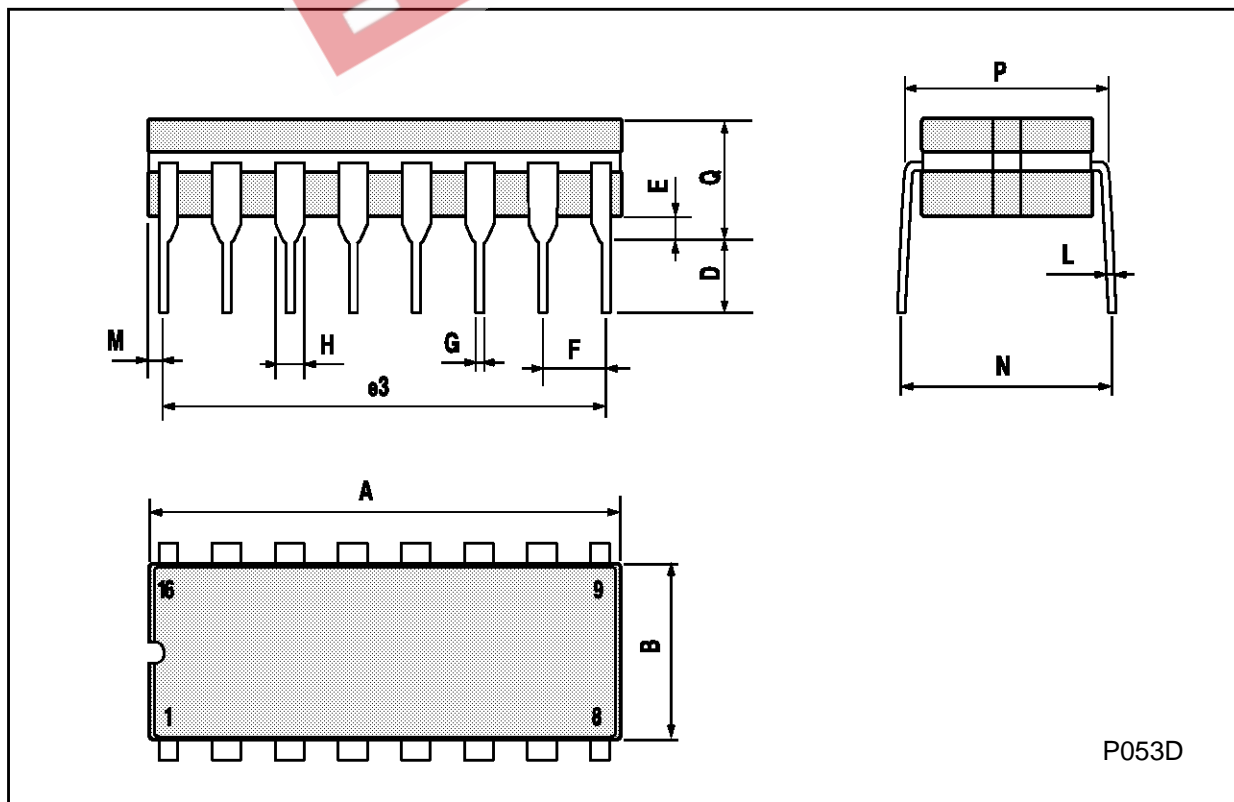

**SO16 (Narrow) MECHANICAL DATA**

DIM.	mm			inch		
	MIN.	TYP.	MAX.	MIN.	TYP.	MAX.
A			1.75			0.068
a1	0.1		0.2	0.004		0.007
a2			1.65			0.064
b	0.35		0.46	0.013		0.018
b1	0.19		0.25	0.007		0.010
C		0.5			0.019	
c1	45° (typ.)					
D	9.8		10	0.385		0.393
E	5.8		6.2	0.228		0.244
e		1.27			0.050	
e3		8.89			0.350	
F	3.8		4.0	0.149		0.157
G	4.6		5.3	0.181		0.208
L	0.5		1.27	0.019		0.050
M			0.62			0.024
S	8° (max.)					

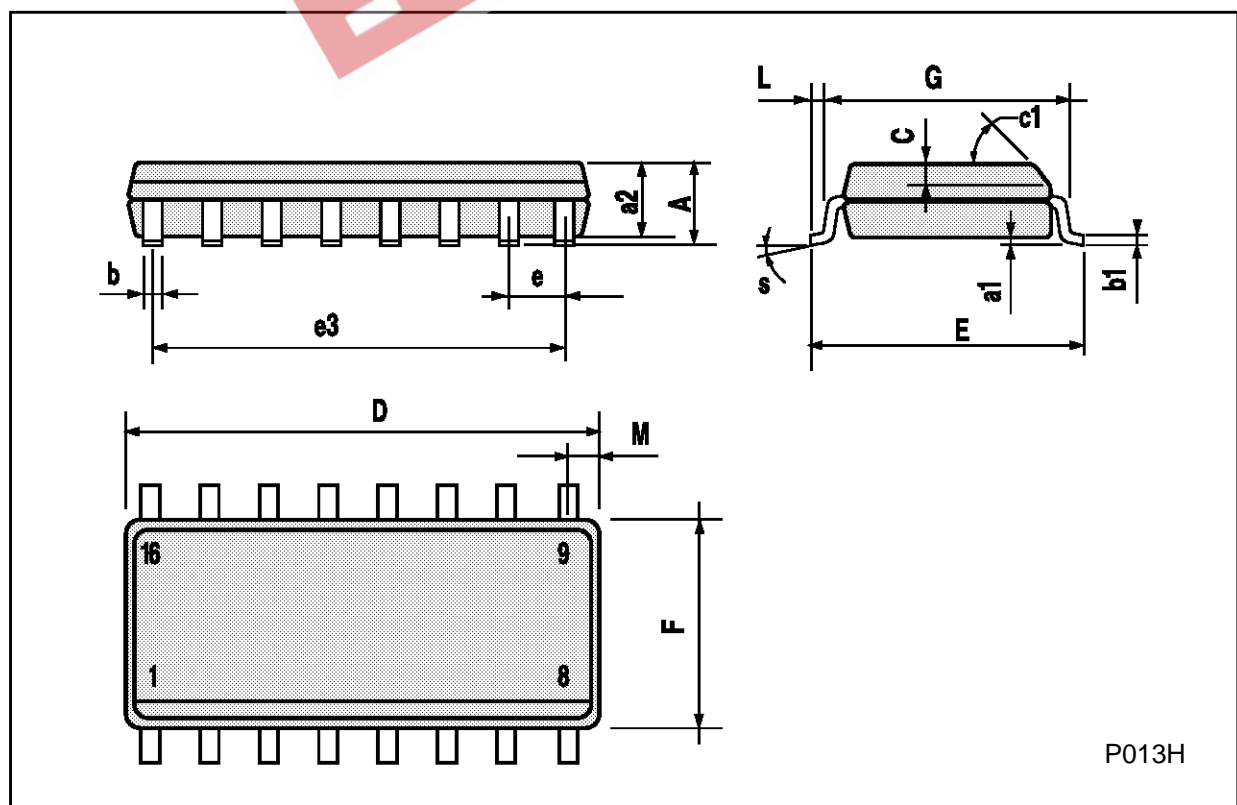

## PLCC20 MECHANICAL DATA

DIM.	mm			inch		
	MIN.	TYP.	MAX.	MIN.	TYP.	MAX.
A	9.78		10.03	0.385		0.395
B	8.89		9.04	0.350		0.356
D	4.2		4.57	0.165		0.180
d1		2.54			0.100	
d2		0.56			0.022	
E	7.37		8.38	0.290		0.330
e		1.27			0.050	
e3		5.08			0.200	
F		0.38			0.015	
G			0.101			0.004
M		1.27			0.050	
M1		1.14			0.045	

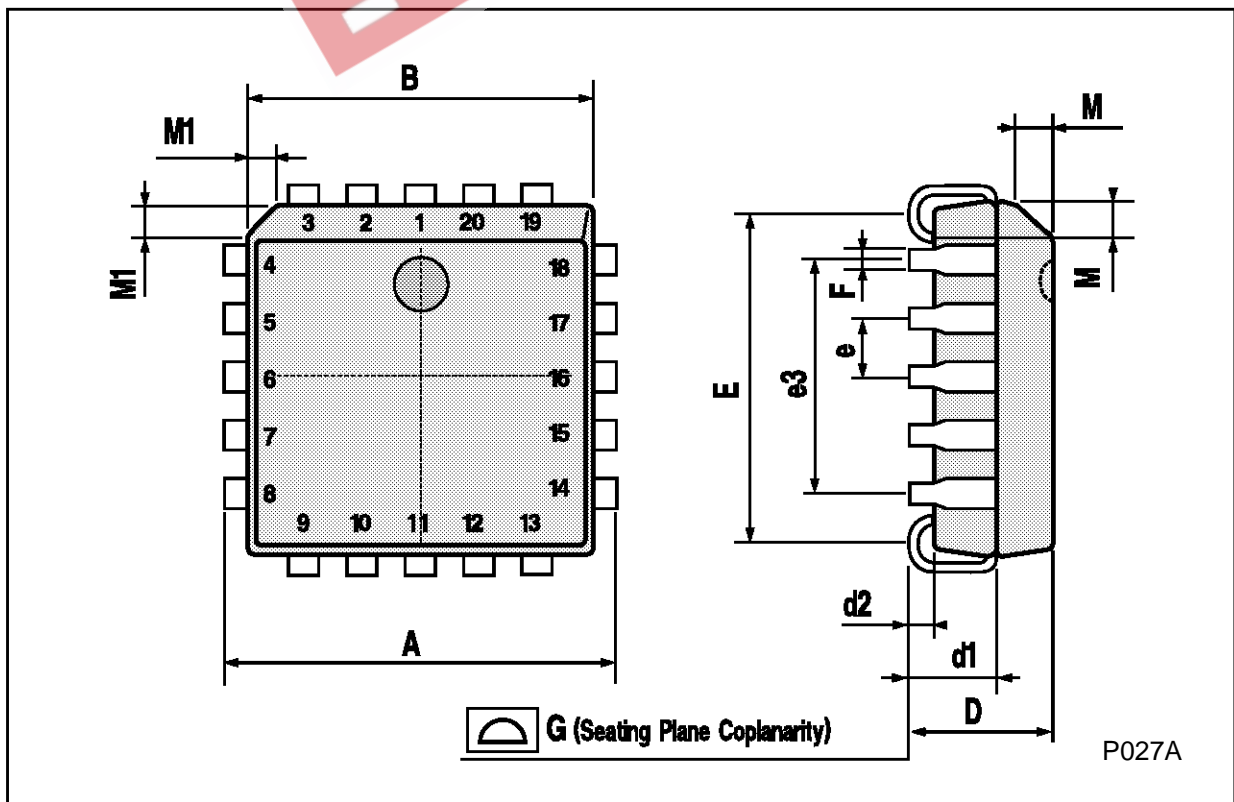

EEPW 电子產品世界  
.com.cn

Information furnished is believed to be accurate and reliable. However, SGS-THOMSON Microelectronics assumes no responsibility for the consequences of use of such information nor for any infringement of patents or other rights of third parties which may result from its use. No license is granted by implication or otherwise under any patent or patent rights of SGS-THOMSON Microelectronics. Specifications mentioned in this publication are subject to change without notice. This publication supersedes and replaces all information previously supplied. SGS-THOMSON Microelectronics products are not authorized for use as critical components in life support devices or systems without express written approval of SGS-THOMSON Microelectronics.

© 1994 SGS-THOMSON Microelectronics - All Rights Reserved

SGS-THOMSON Microelectronics GROUP OF COMPANIES  
Australia - Brazil - France - Germany - Hong Kong - Italy - Japan - Korea - Malaysia - Malta - Morocco - The Netherlands -  
Singapore - Spain - Sweden - Switzerland - Taiwan - Thailand - United Kingdom - U.S.A