

MC14597B
MC14598B

8-Bit Bus-Compatible Latches

The MC14597B and MC14598B are 8-bit latches, one addressed with an internal counter and the other addressed with an external binary address. The 8 latch-outputs are high drive, three-state and bus line compatible. The drive capability allows direct applications with MPU systems such as the Motorola 6800 family.

With MC14597B, a 3-bit address counter (clocked on the falling edge of Increment) selects the appropriate latch. The latches of the MC14598B are accessed via the Address pins, A0, A1, and A2. A Full Flag is provided on the MC14597B to indicate the position of the Address counter.

All 8 outputs from the latches are available in parallel when Enable is in the low state. Data is entered into a selected latch from the Data pin when the Strobe is high. Master reset is available on both parts.

- Serial Data Input
- Three-State Bus Compatible Parallel Outputs
- Three-State Control Pin ($\overline{\text{Enable}}$) TTL Compatible Input
- Open Drain Full Flag (Multiple Latch Wire-O Ring)
- Master Reset
- Level Shifting Inputs on All Except $\overline{\text{Enable}}$
- Diode Protection — All Inputs
- Supply Voltage Range — 3.0 Vdc to 18 Vdc
- Capable of Driving TTL Over Rated Temperature Range
With Fanout as Follows:
1 TTL Load
4 LSTTL Loads

BLOCK DIAGRAMS

MC14597B

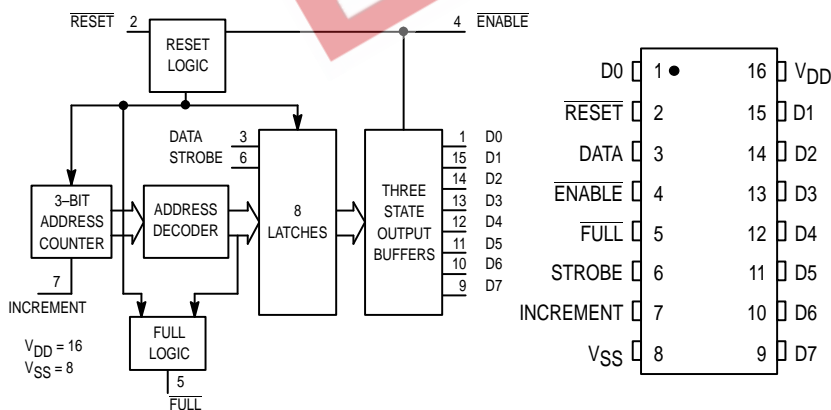

MC14598B

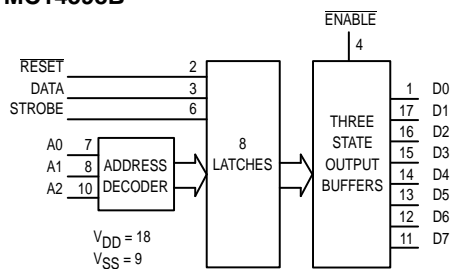

OUTPUT TRUTH TABLE

Enable	Outputs
1	High Impedance
0	D _n

D_n = State of nth latch

NC = NO CONNECTION

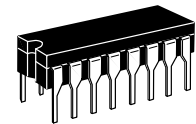

L SUFFIX
CERAMIC
CASE 620

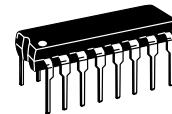

P SUFFIX
PLASTIC
CASE 648



D SUFFIX
SOIC
CASE 751B

ORDERING INFORMATION

MC14597BCP	Plastic
MC14597BCL	Ceramic
MC14597BDW	SOIC

T_A = - 55° to 125°C for all packages.

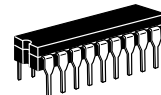

L SUFFIX
CERAMIC
CASE 726

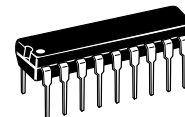

P SUFFIX
PLASTIC
CASE 707

ORDERING INFORMATION

MC14598BCP	Plastic
MC14598BCL	Ceramic

T_A = - 55° to 125°C for all packages.

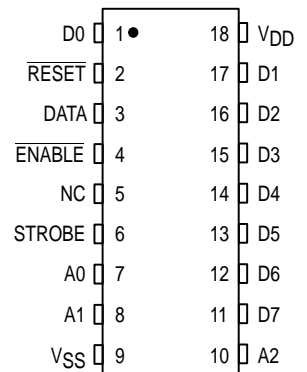

MAXIMUM RATINGS* (Voltages Referenced to V_{SS})

Symbol	Parameter	Value	Unit
V _{DD}	DC Supply Voltage	- 0.5 to + 18.0	V
V _{in}	Input Voltage, Enable (DC or Transient)	- 0.5 to V _{DD} + 0.5	V
V _{in}	Input Voltage, All other Inputs (DC or Transient)	- 0.5 to V _{DD} + 12	V
V _{out}	Output Voltage (DC or Transient)	- 0.5 to V _{DD} + 0.5	V
I _{in, iout}	Input or Output Current (DC or Transient), per Pin	± 10	mA
P _D	Power Dissipation, per Package†	500	mW
T _{stg}	Storage Temperature	- 65 to + 150	°C
T _L	Lead Temperature (8-Second Soldering)	260	°C

This device contains protection circuitry to guard against damage due to high static voltages or electric fields. However, precautions must be taken to avoid applications of any voltage higher than maximum rated voltages to this high-impedance circuit. For proper operation, V_{in} and V_{out} should be constrained to the range V_{SS} ≤ (V_{in} or V_{out}) ≤ V_{DD}. Unused inputs must always be tied to an appropriate logic voltage level (e.g., either V_{SS} or V_{DD}). Unused outputs must be left open.

* Maximum Ratings are those values beyond which damage to the device may occur.

† Temperature Derating:

“P and D/DW” Packages: - 7.0 mW/°C From 65°C To 125°C Ceramic

“L” Packages: - 12 mW/°C From 100°C To 125°C

ELECTRICAL CHARACTERISTICS (Voltages Referenced to V_{SS})

Characteristic	Symbol	V _{DD} Vdc	- 55°C		25°C			125°C		Unit
			Min	Max	Min	Typ #	Max	Min	Max	
Output Voltage V _{in} = V _{DD} or 0	“0” Level V _{OL}	5.0	—	0.05	—	0	0.05	—	0.05	Vdc
		10	—	0.05	—	0	0.05	—	0.05	
		15	—	0.05	—	0	0.05	—	0.05	
V _{in} = 0 or V _{DD}	“1” Level V _{OH}	5.0	4.95	—	4.95	5.0	—	4.95	—	Vdc
		10	9.95	—	9.95	10	—	9.95	—	
		15	14.95	—	14.95	15	—	14.95	—	
Input Voltage** — Enable (V _O = 4.5 or 0.5 Vdc) (V _O = 9.0 or 1.0 Vdc) (V _O = 13.5 or 1.5 Vdc)	“0” Level V _{IL}	5.0	—	0.8	—	1.1	0.8	—	0.8	Vdc
		10	—	1.6	—	2.2	1.6	—	1.6	
		15	—	2.4	—	3.4	2.4	—	2.4	
	“1” Level V _{IH}	5.0	2.0	—	2.0	1.9	—	2.0	—	Vdc
		10	6.0	—	6.0	3.1	—	6.0	—	
		15	10	—	10	4.3	—	10	—	
Input Voltage Other Inputs (V _O = 4.5 or 0.5 Vdc) (V _O = 9.0 or 1.0 Vdc) (V _O = 13.5 or 1.5 Vdc)	“0” Level V _{iL}	5.0	—	1.5	—	2.25	1.5	—	1.5	Vdc
		10	—	3.0	—	4.50	3.0	—	3.0	
		15	—	4.0	—	6.75	4.0	—	4.0	
	“1” Level V _{iH}	5.0	3.5	—	3.5	2.75	—	3.5	—	Vdc
		10	7.0	—	7.0	5.50	—	7.0	—	
		15	11	—	11	8.25	—	11	—	
Output Drive Current (Full — Sink Only) (V _{OH} = 4.6 Vdc) (V _{OH} = 9.5 Vdc) (V _{OH} = 13.5 Vdc)	Source I _{OH}	5.0	- 1.0	—	- 1.0	- 2.0	—	- 1.0	—	mAdc
		10	—	—	—	- 6.0	—	—	—	
		15	—	—	—	- 12	—	—	—	
	Sink I _{OL}	5.0	1.6	—	1.6	3.2	—	1.6	—	mAdc
		10	—	—	—	6.0	—	—	—	
		15	—	—	—	12	—	—	—	
Input Current	I _{in}	15	—	±0.1	—	±0.00001	±0.1	—	±1.0	μAdc
Three-State Leakage Current	I _{TL}	15	—	±0.1	—	±0.00001	±0.1	—	±3.0	μAdc
Input Capacitance (V _{in} = 0)	C _{in}	—	—	—	—	5.0	7.5	—	—	pF
Quiescent Current (Per Package)	I _{DD}	5.0	—	5.0	—	0.005	5.0	—	150	μAdc
		10	—	10	—	0.010	10	—	300	
		15	—	20	—	0.015	20	—	600	
**Total Supply Current at an External Load Capacitance of 130 pF	I _T	5.0 10	I _T = (2.0 μA/kHz) f + I _{DD} I _T = (4.0 μA/kHz) f + I _{DD} I _T = (6.0 μA/kHz) f + I _{DD}							μAdc

† Data labelled “Typ” is not to be used for design purposes but is intended as an indication of the IC’s potential performance.

**The formulas given are for the typical characteristics only at 25°C.

SWITCHING CHARACTERISTICS* ($T_A = 25^\circ\text{C}$, $C_L = 130\text{ pF} + 1\text{ TTL Load}$)

Characteristic	Symbol	VDD Vdc	All Types			Unit
			Min	Typ #	Max	
Output Rise and Fall Time $t_{TLH}, t_{THL} = (0.5\text{ ns/pF}) C_L + 35\text{ ns}$ $t_{TLH}, t_{THL} = (0.2\text{ ns/pF}) C_L + 25\text{ ns}$ $t_{TLH}, t_{THL} = (0.16\text{ ns/pF}) C_L + 20\text{ ns}$	$t_{TLH},$ t_{THL}	5.0 10 15	— — —	100 50 40	200 100 80	ns
Propagation Delay Time Enable to Output Strobe to Output Strobe to $\overline{\text{Full}}$ (MC14597B only) $\overline{\text{Reset}}$ to Output	$t_{PLH},$ t_{PHL}	5.0 10 15 5.0 10 15 5.0 10 15	— — — — — — — — —	160 125 100 200 100 80 200 100 80	320 250 200 400 200 160 400 200 160	ns
Pulse Width Enable Strobe Increment (MC14597B only) $\overline{\text{Reset}}$	$t_{WH},$ t_{WL}	5.0 10 15 5.0 10 15 5.0 10 15 5.0 10 15	— — — — — — — — — — — —	320 240 160 200 100 80 200 100 80 300 160 100	160 120 80 100 50 40 100 50 40 150 80 50	ns
Setup Time Data Address (MC14598B only) Increment (MC14597B only)	t_{su}	5.0 10 15 5.0 10 15 5.0 10 15	100 50 35 200 100 70 400 200 170	50 25 20 100 50 35 200 100 85	— — — — — — — — —	ns
Hold Time Data Address (MC14598B only)	t_h	5.0 10 15 5.0 10 15	100 50 35 100 50 35	50 25 20 50 25 20	— — — — — —	ns
$\overline{\text{Reset}}$ Removal Time	t_{rem}	5.0 10 15	20 20 20	-25 -15 -10	— — —	ns

* The formulas given are for the typical characteristics only at 25°C .

#Data labelled "Typ" is not to be used for design purposes but is intended as an indication of the IC's potential performance.

MC14597B FUNCTION DIAGRAM

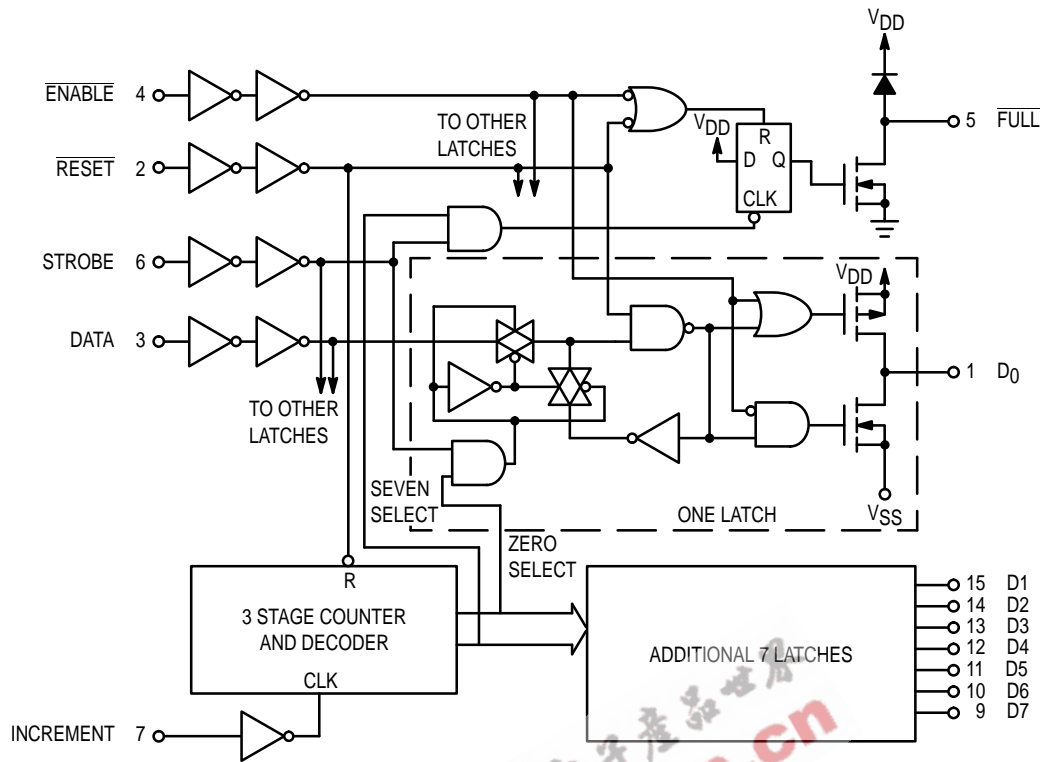

MC14597B TIMING DIAGRAMS

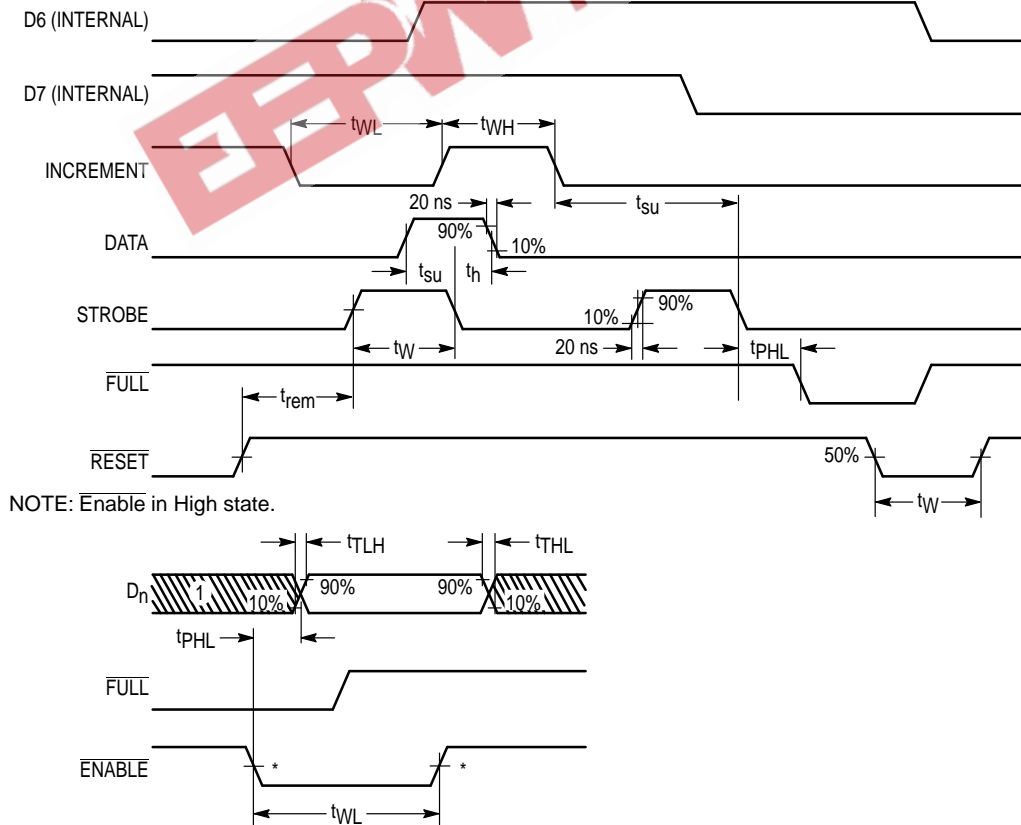

* 1.4 V with $V_{DD} = 5.0$ V

NOTES:

1. High-impedance output state (another device controls bus).
2. Reset in High state.

MC14598B FUNCTION DIAGRAM

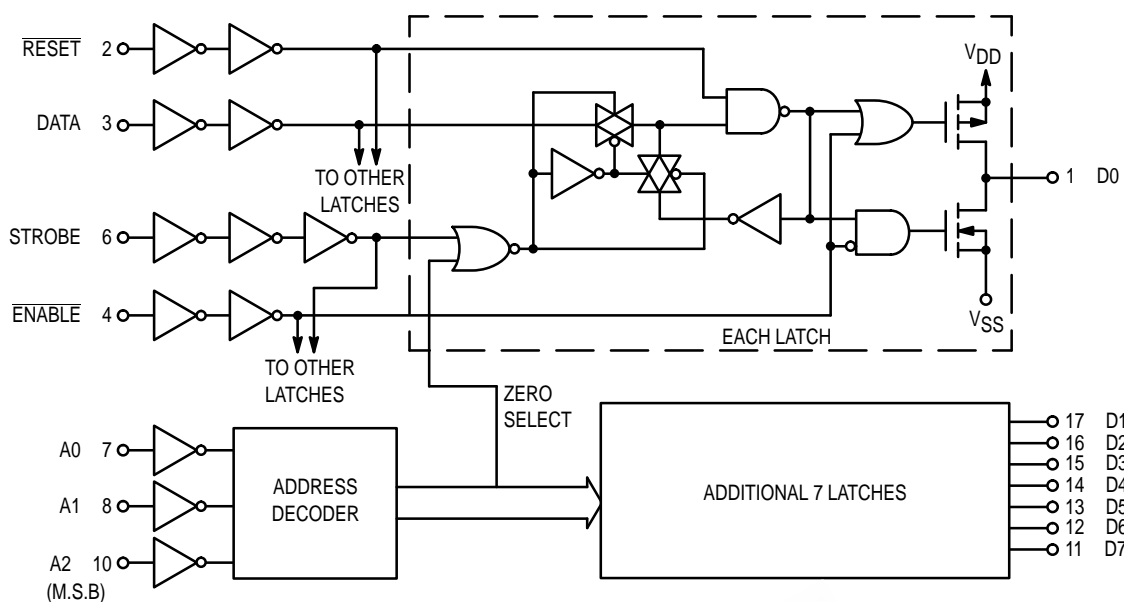

MC14598B TIMING DIAGRAM

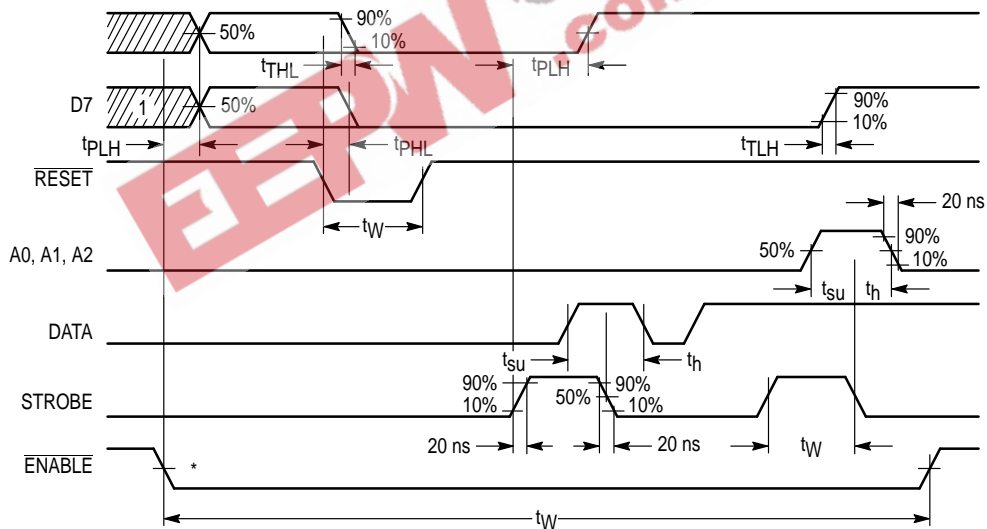

* 1.4 V with $V_{DD} = 5.0$ V

NOTES:

1. High-impedance output state (another device controls bus).
2. Output Load as for MC14597B.



LATCH TRUTH TABLE

Strobe	$\overline{\text{Reset}}$	Address Latch	Other Latches
0	1	*	*
1	1	Data	*
X	0	0	0

* = No change in state of latch

X = Don't care

TRUTH TABLE FOR MC14597B

Increment	$\overline{\text{Enable}}$	$\overline{\text{Reset}}$	Address Counter	$\overline{\text{Full}}$
	X	1	Count Up	—
	X	1	No Change	—
X	1	0	Reset to Zero	Set to One
X	0	1	No Change	Set to One
X	1	1	If at ADDRESS 7	To Zero on Falling Edge of STROBE

X = Don't care

**TEST LOAD
ALL OUTPUTS**

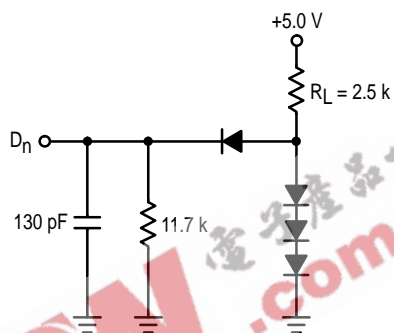

Circuit diagrams external to or containing Motorola products are included as a means of illustration only. Complete information sufficient for construction purposes may not be fully illustrated. Although the information herein has been carefully checked and is believed to be reliable. Motorola assumes no responsibility for inaccuracies. Information herein does not convey to the purchaser any license under the

patent rights of Motorola or others.

The information contained herein is for guidance only, with no warranty of any type, expressed or implied. Motorola reserves the right to make any changes to the information and the product(s) to which the information applies and to discontinue manufacture of the product(s) at any time.

OUTLINE DIMENSIONS

L SUFFIX CERAMIC DIP PACKAGE CASE 620-10 ISSUE V

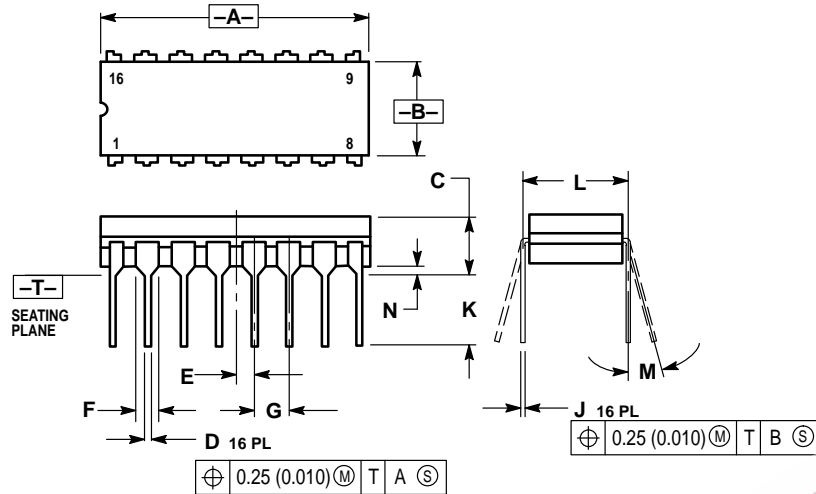

NOTES:

1. DIMENSIONING AND TOLERANCING PER ANSI Y14.5M, 1982.
2. CONTROLLING DIMENSION: INCH.
3. DIMENSION L TO CENTER OF LEAD WHEN FORMED PARALLEL.
4. DIMENSION F MAY NARROW TO 0.76 (0.030) WHERE THE LEAD ENTERS THE CERAMIC BODY.

DIM	INCHES		MILLIMETERS	
	MIN	MAX	MIN	MAX
A	0.750	0.785	19.05	19.93
B	0.240	0.295	6.10	7.49
C	—	0.200	—	5.08
D	0.015	0.020	0.39	0.50
E	0.050 BSC		1.27 BSC	
F	0.055	0.065	1.40	1.65
G	0.100 BSC		2.54 BSC	
H	0.008	0.015	0.21	0.38
K	0.125	0.170	3.18	4.31
L	0.300 BSC		7.62 BSC	
M	0°	15°	0°	15°
N	0.020	0.040	0.51	1.01

P SUFFIX PLASTIC DIP PACKAGE CASE 648-08 ISSUE R

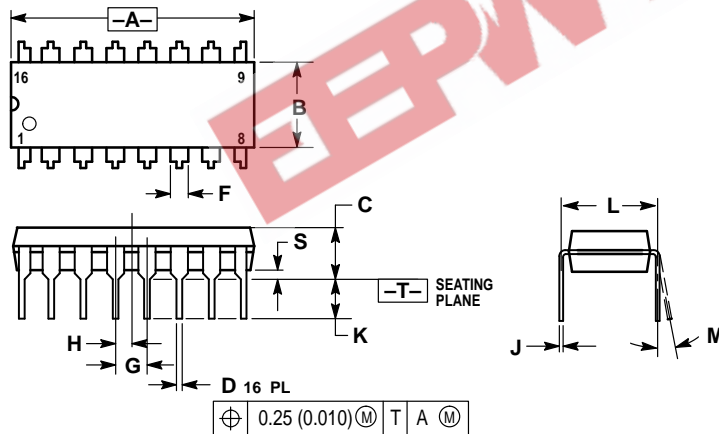

NOTES:

1. DIMENSIONING AND TOLERANCING PER ANSI Y14.5M, 1982.
2. CONTROLLING DIMENSION: INCH.
3. DIMENSION L TO CENTER OF LEADS WHEN FORMED PARALLEL.
4. DIMENSION B DOES NOT INCLUDE MOLD FLASH.
5. ROUNDED CORNERS OPTIONAL.

DIM	INCHES		MILLIMETERS	
	MIN	MAX	MIN	MAX
A	0.740	0.770	18.80	19.55
B	0.250	0.270	6.35	6.85
C	0.145	0.175	3.69	4.44
D	0.015	0.021	0.39	0.53
F	0.040	0.70	1.02	1.77
G	0.100 BSC		2.54 BSC	
H	0.050 BSC		1.27 BSC	
J	0.008	0.015	0.21	0.38
K	0.110	0.130	2.80	3.30
L	0.295	0.305	7.50	7.74
M	0°	10°	0°	10°
S	0.020	0.040	0.51	1.01

OUTLINE DIMENSIONS

D SUFFIX PLASTIC SOIC PACKAGE CASE 751B-05 ISSUE J

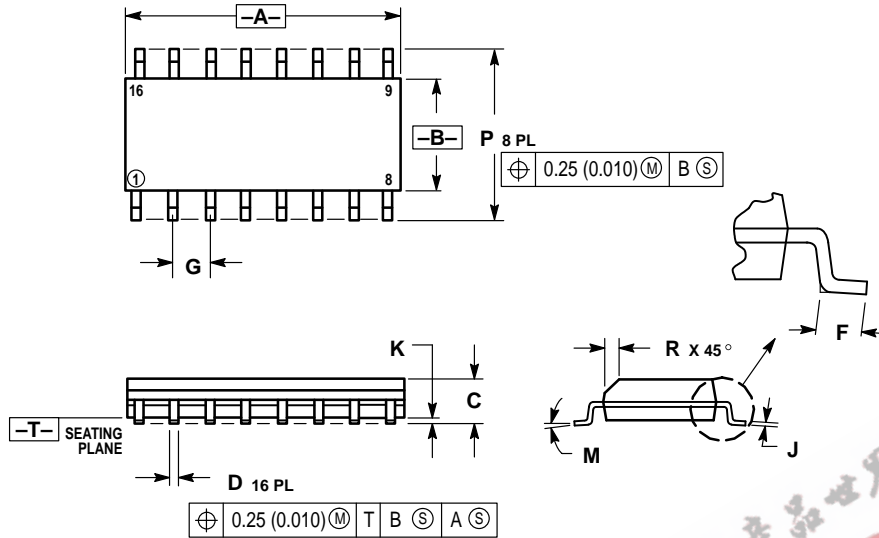

NOTES:

1. DIMENSIONING AND TOLERANCING PER ANSI Y14.5M, 1982.
2. CONTROLLING DIMENSION: MILLIMETER.
3. DIMENSIONS A AND B DO NOT INCLUDE MOLD PROTRUSION.
4. MAXIMUM MOLD PROTRUSION 0.15 (0.006) PER SIDE.
5. DIMENSION D DOES NOT INCLUDE DAMBAR PROTRUSION. ALLOWABLE DAMBAR PROTRUSION SHALL BE 0.127 (0.005) TOTAL IN EXCESS OF THE D DIMENSION AT MAXIMUM MATERIAL CONDITION.

DIM	MILLIMETERS		INCHES	
	MIN	MAX	MIN	MAX
A	9.80	10.00	0.386	0.393
B	3.80	4.00	0.150	0.157
C	1.35	1.75	0.054	0.068
D	0.35	0.49	0.014	0.019
F	0.40	1.25	0.016	0.049
G	1.27 BSC		0.050 BSC	
J	0.19	0.25	0.008	0.009
K	0.10	0.25	0.004	0.009
M	0°	7°	0°	7°
P	5.80	6.20	0.229	0.244
R	0.25	0.50	0.010	0.019

L SUFFIX CERAMIC DIP PACKAGE CASE 726-04 ISSUE G

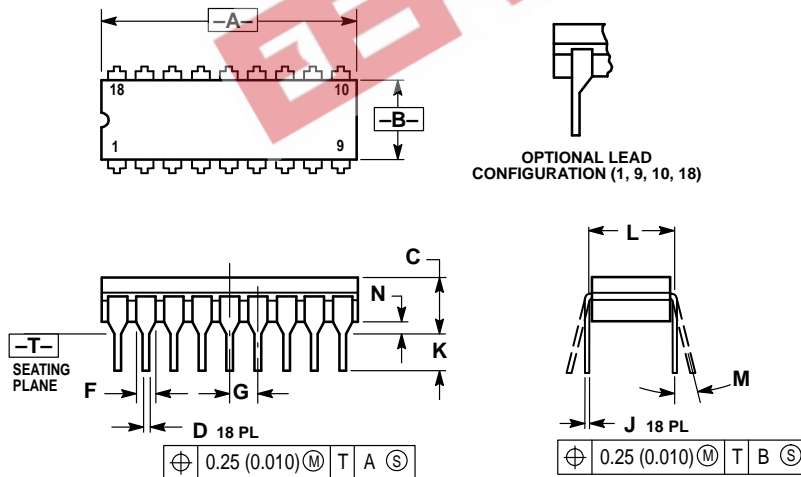

NOTES:

1. DIMENSIONING AND TOLERANCING PER ANSI Y14.5M, 1982.
2. CONTROLLING DIMENSION: INCH.
3. DIMENSION L TO CENTER OF LEAD WHEN FORMED PARALLEL.
4. DIMENSION F FOR FULL LEADS. HALF LEADS OPTIONAL AT LEAD POSITIONS 1, 9, 10, AND 18.

DIM	INCHES		MILLIMETERS	
	MIN	MAX	MIN	MAX
A	0.880	0.910	22.35	23.11
B	0.240	0.295	6.10	7.49
C	—	0.200	—	5.08
D	0.015	0.021	0.38	0.53
F	0.055	0.070	1.40	1.78
G	0.100 BSC		2.54 BSC	
J	0.008	0.012	0.20	0.30
K	0.125	0.170	3.18	4.32
L	0.300 BSC		7.62 BSC	
M	0°	15°	0°	15°
N	0.020	0.040	0.51	1.02

**P SUFFIX
PLASTIC DIP PACKAGE
CASE 707-02
ISSUE C**

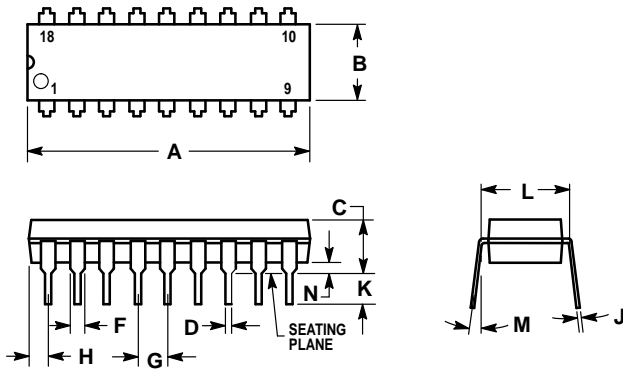

NOTES:

1. POSITIONAL TOLERANCE OF LEADS (D), SHALL BE WITHIN 0.25 (0.010) AT MAXIMUM MATERIAL CONDITION, IN RELATION TO SEATING PLANE AND EACH OTHER.
2. DIMENSION L TO CENTER OF LEADS WHEN FORMED PARALLEL.
3. DIMENSION B DOES NOT INCLUDE MOLD FLASH.

DIM	MILLIMETERS		INCHES	
	MIN	MAX	MIN	MAX
A	22.22	23.24	0.875	0.915
B	6.10	6.60	0.240	0.260
C	3.56	4.57	0.140	0.180
D	0.36	0.56	0.014	0.022
F	1.27	1.78	0.050	0.070
G	2.54 BSC		0.100 BSC	
H	1.02	1.52	0.040	0.060
J	0.20	0.30	0.008	0.012
K	2.92	3.43	0.115	0.135
L	7.62 BSC		0.300 BSC	
M	0°	15°	0°	15°
N	0.51	1.02	0.020	0.040



Motorola reserves the right to make changes without further notice to any products herein. Motorola makes no warranty, representation or guarantee regarding the suitability of its products for any particular purpose, nor does Motorola assume any liability arising out of the application or use of any product or circuit, and specifically disclaims any and all liability, including without limitation consequential or incidental damages. "Typical" parameters which may be provided in Motorola data sheets and/or specifications can and do vary in different applications and actual performance may vary over time. All operating parameters, including "Typicals" must be validated for each customer application by customer's technical experts. Motorola does not convey any license under its patent rights nor the rights of others. Motorola products are not designed, intended, or authorized for use as components in systems intended for surgical implant into the body, or other applications intended to support or sustain life, or for any other application in which the failure of the Motorola product could create a situation where personal injury or death may occur. Should Buyer purchase or use Motorola products for any such unintended or unauthorized application, Buyer shall indemnify and hold Motorola and its officers, employees, subsidiaries, affiliates, and distributors harmless against all claims, costs, damages, and expenses, and reasonable attorney fees arising out of, directly or indirectly, any claim of personal injury or death associated with such unintended or unauthorized use, even if such claim alleges that Motorola was negligent regarding the design or manufacture of the part. Motorola and are registered trademarks of Motorola, Inc. Motorola, Inc. is an Equal Opportunity/Affirmative Action Employer.

How to reach us:

USA/EUROPE/Locations Not Listed: Motorola Literature Distribution;
P.O. Box 20912; Phoenix, Arizona 85036. 1-800-441-2447 or 602-303-5454

JAPAN: Nippon Motorola Ltd.; Tatsumi-SPD-JLDC, 6F Seibu-Butsuryu-Center,
3-14-2 Tatsumi Koto-Ku, Tokyo 135, Japan. 03-81-3521-8315

MFAX: RMFAX0@email.sps.mot.com – TOUCHTONE 602-244-6609
INTERNET: <http://Design-NET.com>

ASIA/PACIFIC: Motorola Semiconductors H.K. Ltd.; 8B Tai Ping Industrial Park,
51 Ting Kok Road, Tai Po, N.T., Hong Kong. 852-26629298



MC14597B/D

