

P10C68/P11C68

(Previously PNC10C68 and PNC11C68)

CMOS/SNOS NVSRAM

HIGH PERFORMANCE 8 K x 8 NON-VOLATILE STATIC RAM

(Supersedes DS3159-1.3, DS3160-1.3, DS3234-1.1, DS3235-1.1)

The P10C68 and P11C68 are fast static RAMs (35 and 45 ns) with a non-volatile electrically-erasable PROM (EEPROM) cell incorporating in each static memory cell. The SRAM can be read and written an unlimited number of times while independent non-volatile data resides in PROM.

On the P10C68 data may easily be transferred from the SRAM to the EEPROM (STORE) and from the EEPROM back to the SRAM (RECALL) using the NE (bar) pin. The Store and Recall cycles are initiated through software sequences on the P11C68. These devices combine the high performance and ease of use of a fast SRAM with the data integrity of non-volatility.

The P10C68 and P11C68 feature the industry standard pinout for non-volatile RAMs in a 28-pin 0.3-inch plastic and ceramic dual-in-line packages.

FEATURES

- Non-Volatile Data Integrity
- 10 year Data Retention in EEPROM
- 35ns and 45ns Address and Chip Enable Access Times
- 20ns and 25ns Output Enable Access
- Unlimited Read and Write to SRAM
- Unlimited Recall Cycles from EEPROM
- 10⁴ Store Cycles to EEPROM
- Automatic Recall on Power up
- Automatic Store Timing
- Hardware Store Protection
- Single 5V ± 10% Operation
- Available in Standard Package 28-pin 0.3-inch DIL plastic and ceramic
- Commercial and Industrial temperature ranges

ORDERING INFORMATION

(See back page)

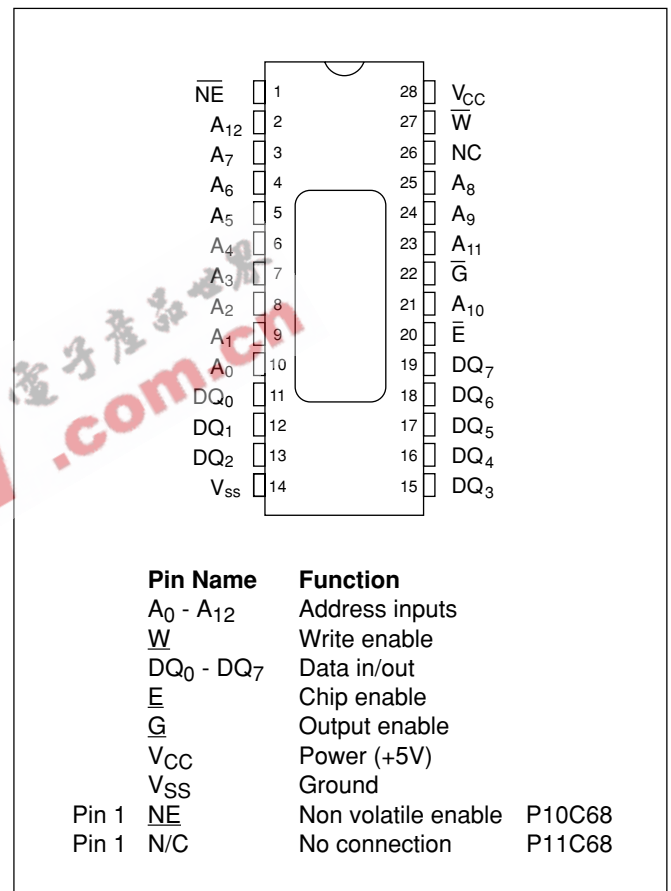

Figure 1. Pin connections - top view.

P10C68/P11C68

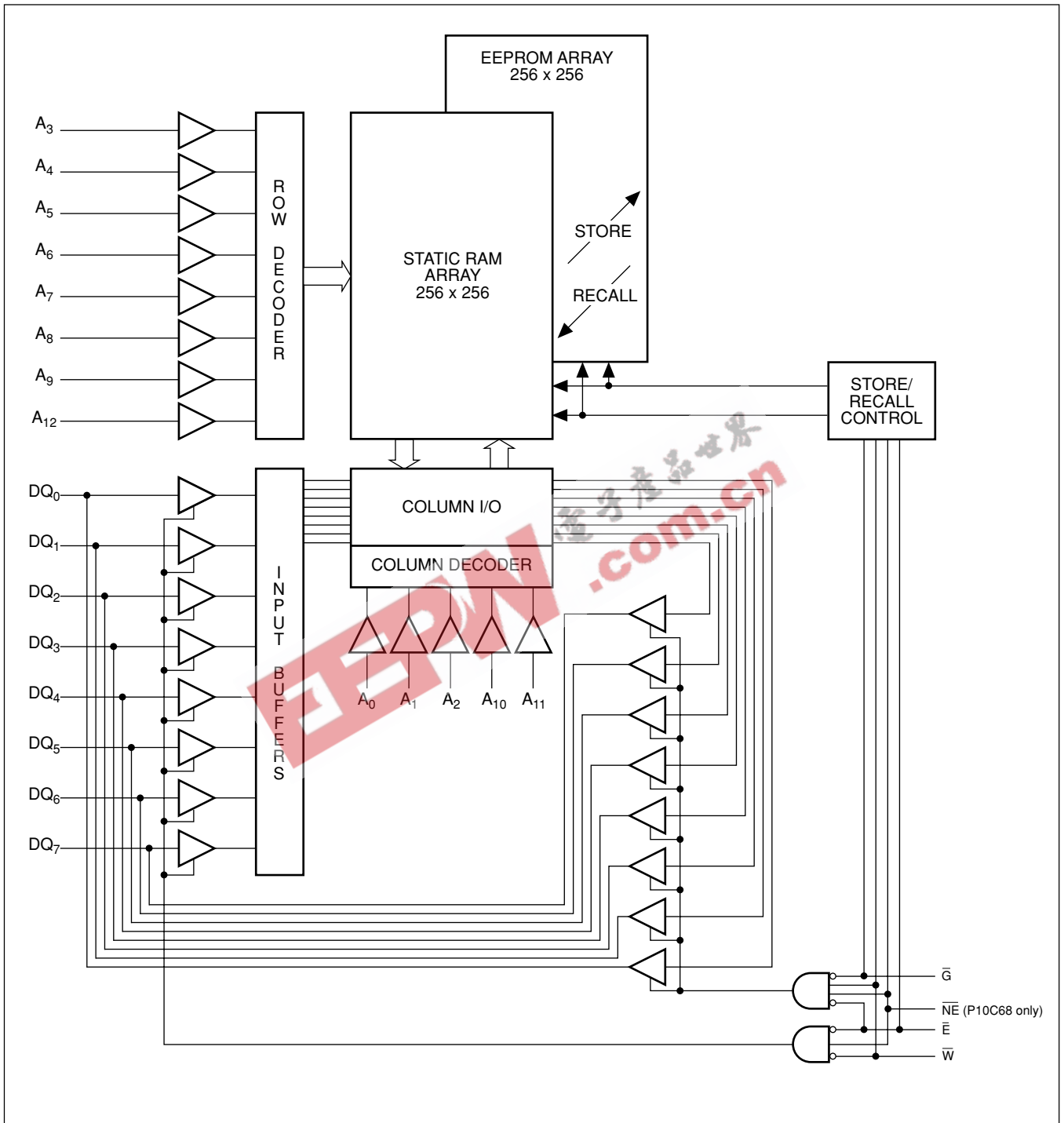

Figure 2. Logic block diagram.

ABSOLUTE MAXIMUM RATINGS

Voltage on typical input relative to VSS	-0.6V to 7.0V
Voltage on DQ0-7 and G(bar)	-0.5V to (V _{CC} + 0.5V)
Temperature under Bias	-55°C to + 125°C
Storage temperature	-65°C to + 150°C
Power dissipation	1W
DC output current (one output at a time, one second duration)	15mA

NOTE

Stresses greater than those listed in the Absolute Maximum Ratings may cause permanent damage to the device. These are stress ratings only; functional operation of the device at any other conditions than those indicated in the operational sections of the specification is not implied. Exposure to absolute maximum ratings conditions for extended periods may affect reliability.

DC OPERATING CONDITIONS

Parameter	Symbol	Value			Units	Conditions
		Min.	Typ.	Max.		
Supply voltage	V _{CC}		5.0		V	
Input logic '1' voltage	V _{IH}	2.2		V _{CC} + 0.5	V	All inputs
Input logic '0' voltage	V _{IL}	V _{SS} - 0.5		0.8	V	All inputs
Ambient operating temperature commercial	T _{amb}	0		+70	°C	
industrial	T _{amb}	-40		+85	°C	

DC ELECTRICAL CHARACTERISTICS

Commercial temperature range

Test conditions (unless otherwise stated):

T_{amb} = 0°C to 70°C, V_{CC} = +5V (See notes 1, 2 and 3)

Characteristic	Symbol	Value		Units	Conditions
		Min.	Max.		
Average power supply current	I _{CC1}		75 65	mA mA	t _{AVAV} = 35ns t _{AVAV} = 45ns
Average power supply current during STORE cycle	I _{CC2}		50	mA	All inputs at V _{IN} ≤ 0.2V
Average power supply current (standby, cycling TTL input levels)	I _{SB1}		23 20	mA mA	t _{AVAV} = 35ns t _{AVAV} = 45ns E(bar) ≥ V _{IH} , all other inputs cycling
Average power supply current (standby, stable CMOS input levels)	I _{SB2}		1	mA	E (bar) ≥ (V _{CC} - 0.2V), all other inputs at V _{IN} ≤ 0.2V or ≥ (V _{CC} - 0.2V)
Input leakage current (any input)	I _{ILK}		±1	µA	V _{CC} = max, V _{IN} = V _{SS} to V _{CC}
Off state output leakage current	I _{OLK}		±5	µA	V _{CC} = max, V _{IN} = V _{SS} to V _{CC}
Output logic '1' voltage	V _{OH}	2.4		V	I _{OUT} = 4mA
Output voltage '0' voltage	V _{OL}		0.4	V	I _{OUT} = 8mA

NOTES

- I_{CC1} is dependent on output loading and cycle rate. The specified values are obtained with outputs unloaded.
- Bringing E (bar) ≥ V_{IH} will not produce standby currents levels until any non-volatile cycle in progress has timed out. See Mode Selection table.
- I_{CC2} is the average current required for the duration of the STORE cycle (t_{STORE}) after the sequence that initiates the cycle.

P10C68/P11C68

Industrial temperature range

Test conditions (unless otherwise stated):

T_{amb} = -40°C to 70°C, V_{cc} = +5V ± 10% (See notes 4, 5 and 6)

Characteristic	Symbol	Value		Units	Conditions
		Min.	Max.		
Average power supply current	I _{CC1}		80 75	mA mA	t _{AVAV} = 35ns t _{AVAV} = 45ns
Average power supply current during STORE cycle	I _{CC2}		50	mA	All inputs at V _{IN} ≤ 0.2V
Average power supply current (standby, cycling TTL input levels)	I _{SB1}		27 23	mA mA	t _{AVAV} = 35ns t _{AVAV} = 45ns E(bar) ≥ V _{IH} , all other inputs cycling
Average power supply current (standby, stable CMOS input levels)	I _{SB2}		1	mA	E (bar) ≥ (V _{CC} - 0.2V), all other inputs at V _{IN} ≤ 0.2V or ≥ (V _{CC} - 0.2V)
Input leakage current (any input)	I _{ILK}		±1	μA	V _{CC} = max, V _{IN} = V _{SS} to V _{CC}
Off state output leakage current	I _{OLK}		±5	μA	V _{CC} = max, V _{IN} = V _{SS} to V _{CC}
Output logic '1' voltage	V _{OH}	2.4		V	I _{OUT} = 4mA
Output voltage '0' voltage	V _{OL}		0.4	V	I _{OUT} = 8mA

NOTES

- I_{CC1} is dependent on output loading and cycle rate. The specified values are obtained with outputs unloaded.
- Bringing E (bar) ≥ V_{IH} will not produce standby currents levels until any non-volatile cycle in progress has timed out. See Mode Selection table.
- I_{CC2} is the average current required for the duration of the STORE cycle (t_{STORE}) after the sequence that initiates the cycle.

AC TEST CONDITIONS

Input pulse levels	V _{SS} to 3V
Input rise and fall times	≤5ns
Input and output timing reference levels	1.5V
Output load	See Figure 3

CAPACITANCE T_{amb} = 25°C, f = 1.0MHz (see note 7)

Parameter	Symbol	Max.	Units	Conditions
Input capacitance	C _{IN}	5	pF	ΔV=0 to 3V
Output capacitance	C _{OUT}	7	pF	ΔV=0 to 3V

NOTE

- These parameters are characterised but not 100% tested.

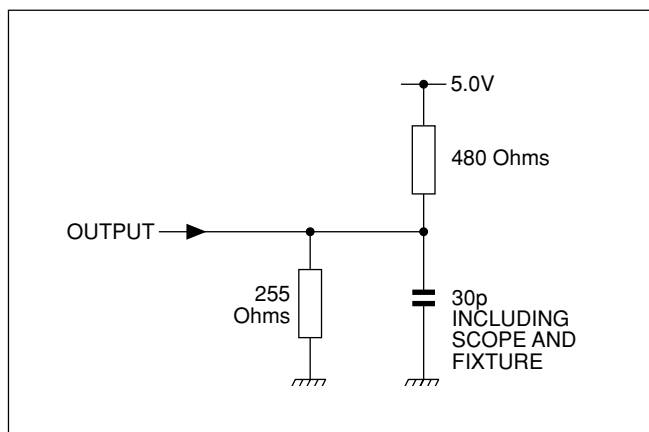

Figure 3. AC output loading.

SRAM MEMORY OPERATION

Test conditions (unless otherwise stated):
Commercial and Industrial Temperature Range
 Tamb = -40°C to + 85°C, Vcc = + 5V ± 10%

READ CYCLES 1 AND 2 (See note 8)

Symbol		Parameter	P10C68-35 P11C68-35		P10C68-45 P11C68-45		Units	Notes
Standard	Alternative		Min.	Max.	Min.	Max.		
t _{ELQV}	t _{ACS}	Chip enable access time		35		45	ns	
t _{AVAV}	t _{RC}	Read cycle time	35	35	45	45	ns	9
t _{AVQV}	t _{AA}	Address access time		35		45	ns	10
t _{GLQV}	t _{OE}	Output enable to data valid		20		25	ns	
t _{AXQX}	t _{OH}	Output hold after address change	5		5		ns	
t _{ELQX}	t _{LZ}	Chip enable to output active	5		5		ns	
t _{EHQZ}	t _{OHZ}	Chip disable to output inactive		20		25	ns	11
t _{GLQX}	t _{OLZ}	Output enable to output active	0		0		ns	
t _{GHQZ}	t _{HZ}	Output disable to output inactive		15		20	ns	11
t _{ELICCH}	t _{PA}	Chip enable to power active	0		0		ns	12
t _{EHICCL}	t _{PS}	Chip disable to power standby		25		25	ns	12
t _{WHQV}	t _{WR}	Write recovery time		45		55	ns	

NOTES

8. E (bar), G (bar) and W (bar) must make the transition between VIH(min) to VIL(max), or VIL(max) to VIH(min) in a monotonic fashion. NE (bar) must be ≥ VIH during entire cycle.
9. For READ CYCLE 1 and 2, W (bar) and NE (bar) must be high for entire cycle.
10. Device is continuously selected with E (bar) low, and G (bar) low.
11. Measured ±200mV from steady state output voltage. Load capacitance is 5pF.
12. Parameter guaranteed but not tested.

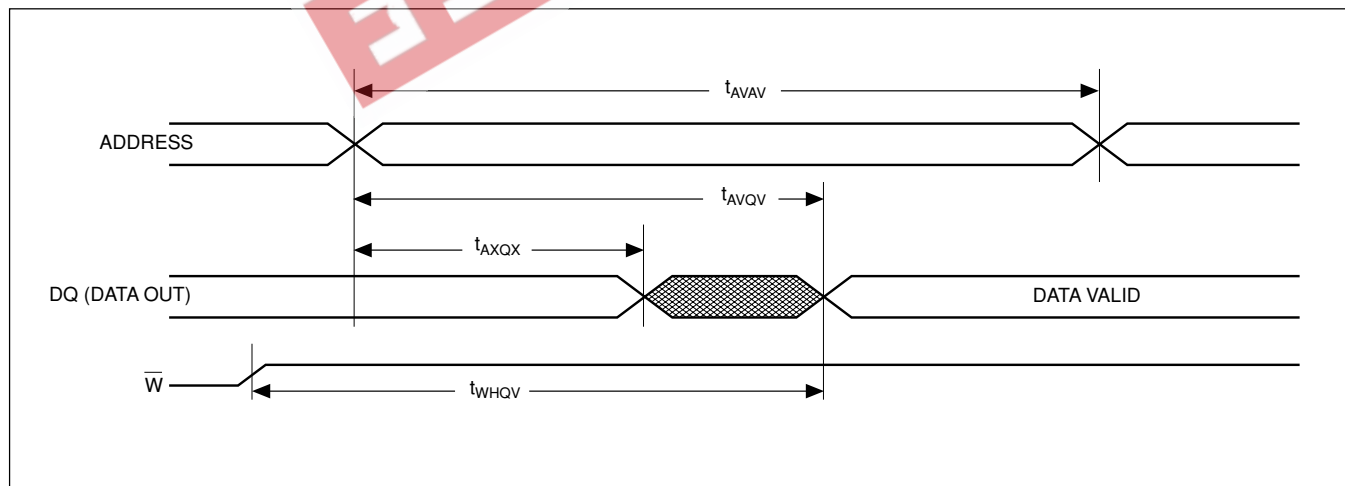

Figure 4. READ CYCLE 1 timing diagram (see notes 9 and 10).

P10C68/P11C68

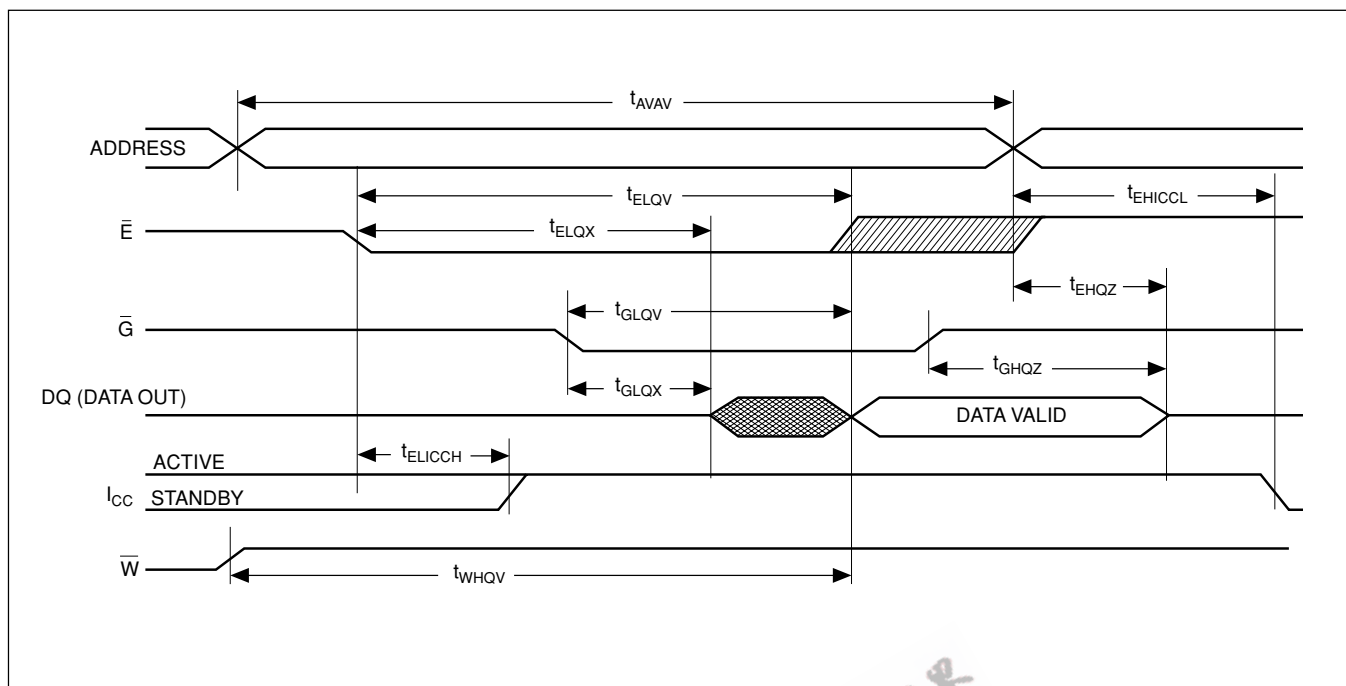

Figure 5. READ CYCLE 2 timing diagram (see note 9).

WRITE CYCLE 1 : W (BAR) CONTROLLED (See notes 8 and 13) Commercial and Industrial Temperature Range

Symbol		Parameter	P10C68-35 P11C68-35		P10C68-45 P11C68-45		Units	Notes
Standard	Alternative		Min.	Max.	Min.	Max.		
tAVAV	tWC	Write cycle time	45		45		ns	
tWLWH	tWP	Write pulse width	35		35		ns	
tELWH	tCW	Chip enable to end of write	35		35		ns	
tDVWH	tDW	Data set-up to end of write	30		30		ns	
tWHDX	tDH	Data hold after end of write	0		0		ns	
tAVWH	tAW	Address set-up to end of write	35		35		ns	
tAVWL	tAS	Address set-up to start of write	0		0		ns	
tWHAX	tWR	Address hold after end of write	0		0		ns	
tWLQZ	tWZ	Write enable to output disable		35		35	ns	11, 14
tWHQZ	tOW	Output active after end of write	5		5		ns	

NOTES

- E (bar) or W (bar) must be $\geq V_{IH}$ during address transitions.
- If W (bar) is low when E (bar) goes low, the outputs remain in the high impedance state.

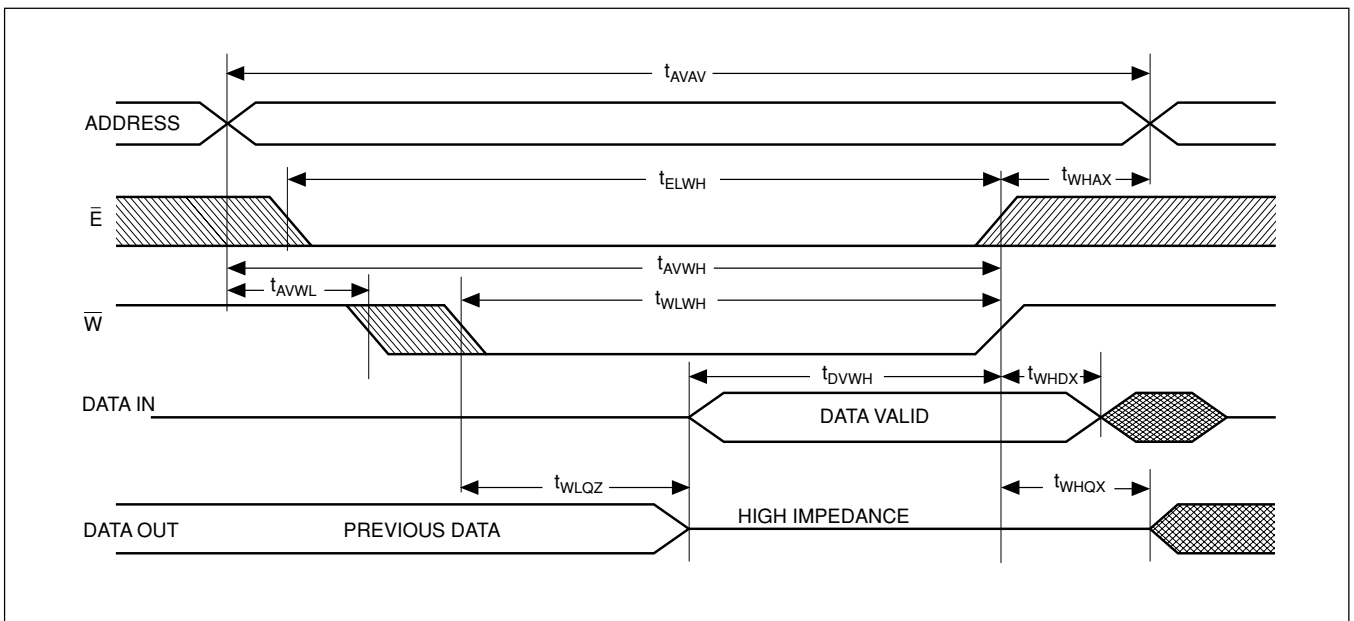

Figure 6. WRITE CYCLE 1: W (bar) controlled timing diagram (see notes 8 and 13).

WRITE CYCLE 2 : E (BAR) CONTROLLED (See notes 8 and 13)

Symbol		Parameter	P10C68-35 P11C68-35		P10C68-45 P11C68-45		Units	Notes
Standard	Alternative		Min.	Max.	Min.	Max.		
t_{AVAV}	t_{WC}	Write cycle time	45		45		ns	
t_{WLEH}	t_{WP}	Write pulse width	35		35		ns	
t_{ELEH}	t_{CW}	Chip enable to end of write	35		35		ns	
t_{DVEH}	t_{DW}	Data set-up to end of write	30		30		ns	
t_{EHDX}	t_{DH}	Data hold after end of write	0		0		ns	
t_{AVEH}	t_{AW}	Address set-up to end of write	35		35		ns	
t_{EHAX}	t_{WR}	Address hold after end of write	0		0		ns	
t_{AVWL}	t_{AS}	Address set-up to start of write	0		0		ns	

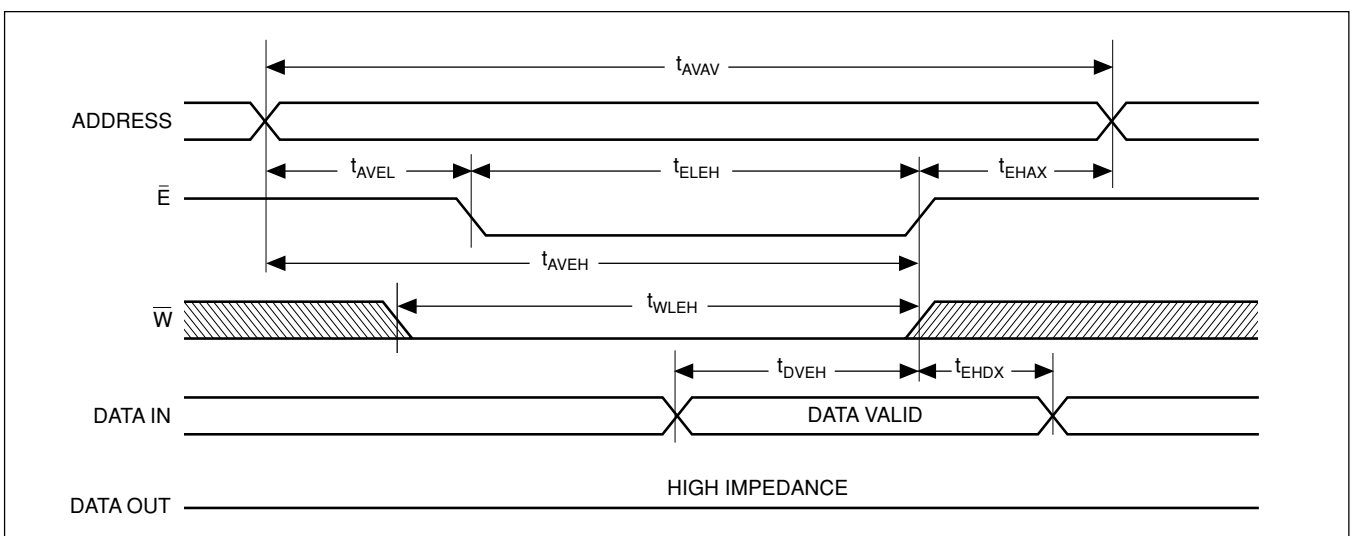

Figure 7. WRITE CYCLE 2: E (bar) controlled timing diagram (see notes 8 and 13).

P10C68/P11C68

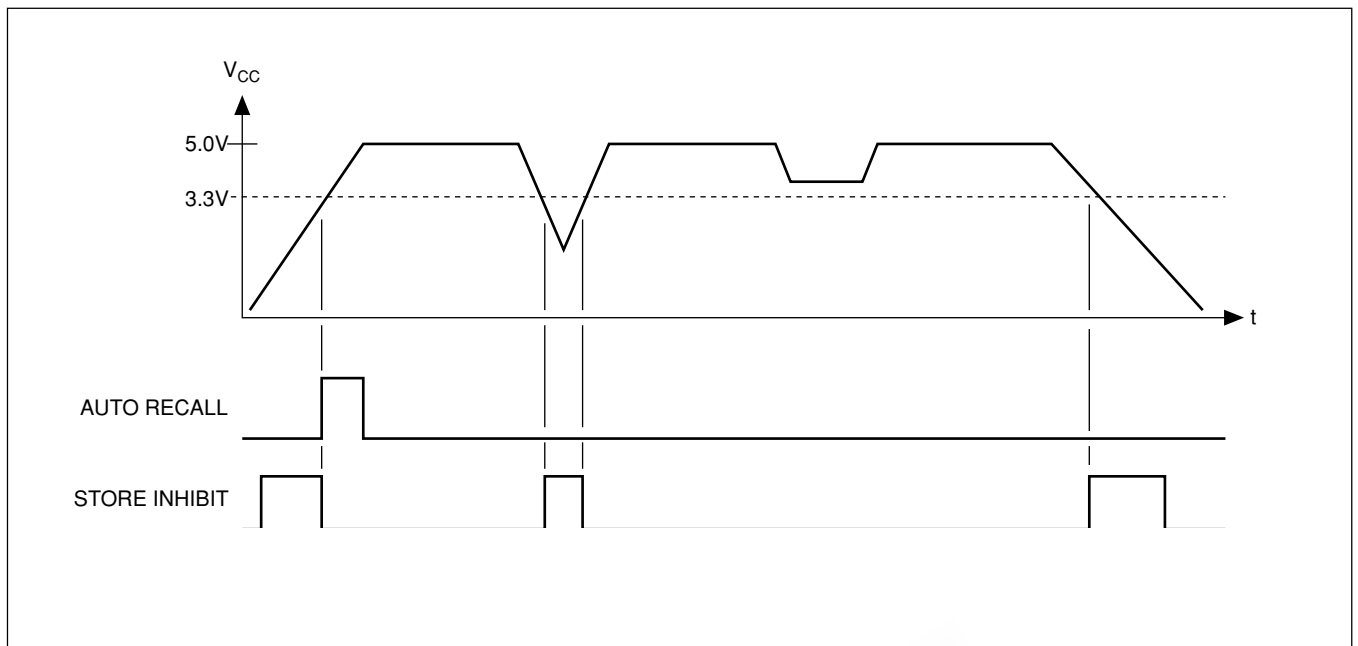

Figure 8. Automatic RECALL and STORE inhibit.

NON-VOLATILE MEMORY OPERATION OF P10C68 MODE SELECTION

<u>E</u>	<u>W</u>	<u>G</u>	<u>NE</u>	Mode	Power
H	X	X	X	Not selected	Standby
L	H	L	H	Read RAM	Active
L	L	X	H	Write RAM	Active
L	H	L	L	Non-volatile recall (Note 15)	Active
L	L	H	L	Non-volatile store	I_{CC2}
L	L	L	L	No operation	Active
L	H	H	X		

NOTE

15. An automatic RECALL also takes place on chip power-up, starting when V_{CC} exceeds 3.3V, and taking t_{RECALL} from the time at which V_{CC} exceeds 3.3V. V_{CC} must not drop below 3.3V once it has exceeded it for the RECALL to function properly.

STORE CYCLE 1 : W (BAR) CONTROLLED (See note 16)

Symbol		Parameter	P10C68-35		P10C68-45		Units	Notes
Standard	Alternative		Min.	Max.	Min.	Max.		
t_{WLQX}	t_{STORE}	Store cycle time		10		10	ms	17
t_{GHNL}		Output disable set-up to NE (bar) fall	0		0		ns	
t_{NLWL}		Non-volatile set-up to write low	0		0		ns	
t_{WLNH}	t_{WC}	Write low to NE (bar) rise	45		45		ns	18
t_{ELWL}		Chip enable SET-UP	0		0		ns	

STORE CYCLE 2 : E (BAR) CONTROLLED (See note 13)

Symbol		Parameter	P10C68-35		P10C68-45		Units	Notes
Standard	Alternative		Min.	Max.	Min.	Max.		
t_{ELQX1}	t_{STORE}	Store cycle time		10		10	ms	17
t_{NLEL}		NE (bar) set-up to chip enable	0		0		ns	
t_{WLEL}		Write enable wet-up to chip enable	0		0		ns	
t_{ELNH}	t_{WC}	Chip enable to NE (bar) rise	45		45		ns	18
t_{GHEL}		Output disable set-up to E (bar) fall	0		0		ns	

NOTES

16. E (bar), G (bar), NE (bar) and W (bar) must make the transition between VIH(max) to VIL(max), or VIL(max) to VIH(min) in a monotonic fashion.

17. Measured with W (bar) and NE (bar) both returned high, and G (bar) returned low. Note that store cycles are inhibited/aborted by $V_{CC} < 3.3V$ (STORE inhibit).

18. Once t_{wc} has been satisfied by NE (bar), G (bar), W (bar) and E (bar) the store cycle is completed automatically, ignoring all inputs. Any of NE (bar), G (bar), W (bar) or E (bar) may be used to terminate the store initiation cycle.

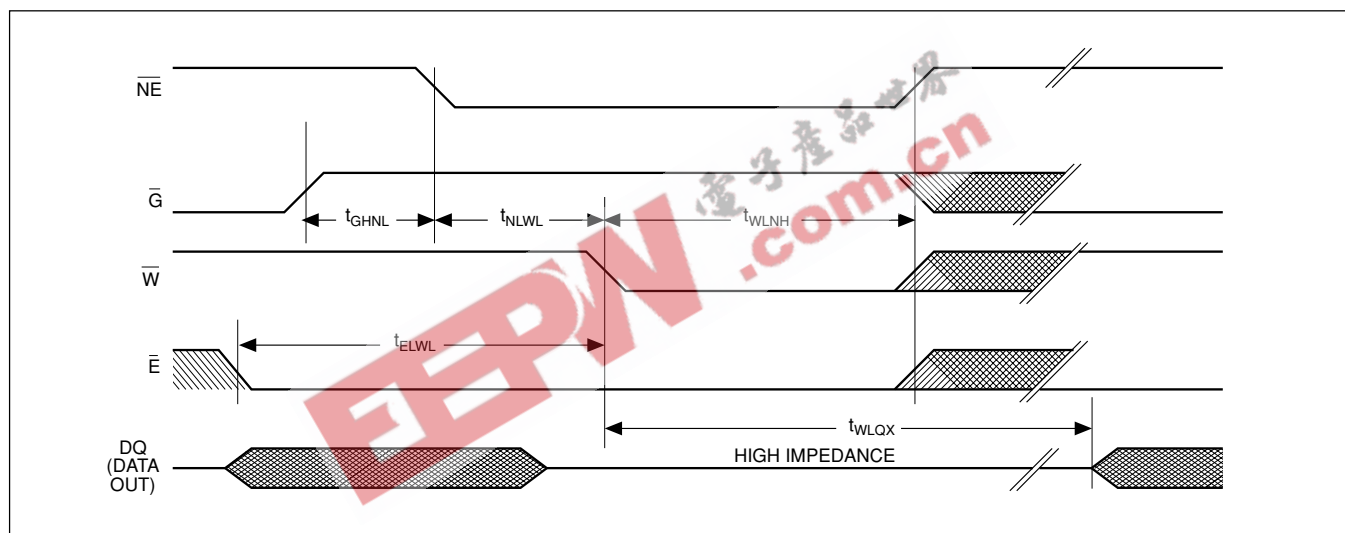

Figure 9. STORE CYCLE 1: W (bar) controlled timing diagram (see note 16).

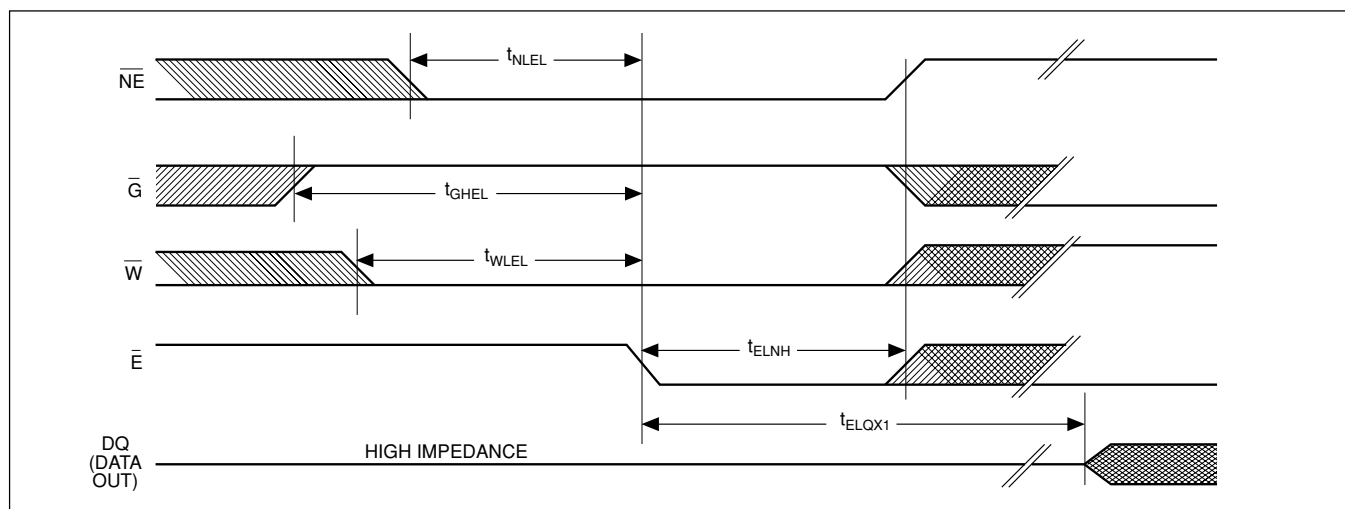

Figure 10. STORE CYCLE 2: E (bar) controlled timing diagram (see note 16).

P10C68/P11C68

P10C68 RECALL CYCLE 1 : NE (BAR) CONTROLLED (See note 16)

Symbol		Parameter	P10C68-35		P10C68-45		Units	Notes
Standard	Alternative		Min.	Max.	Min.	Max.		
t _{NLQX}	t _{RECALL}	Recall cycle time		20		20	μs	19
t _{NLNH}	t _{RC}	Recall initiation cycle time	25		25		μs	20
t _{GLNL}		Output enable set-up	0		0		ns	
t _{WHNL}		Write enable set-up	0		0		ns	
t _{ELNL}		Chip enable set-up	0		0		ns	
t _{NLQZ}		NE (bar) fall to output inactive		25		25	ns	

P10C68 RECALL CYCLE 2 : E (BAR) CONTROLLED (See note 16)

Symbol		Parameter	P10C68-35		P10C68-45		Units	Notes
Standard	Alternative		Min.	Max.	Min.	Max.		
t _{ELQX2}	t _{RECALL}	Recall cycle time		20		20	μs	19
t _{ELNH}	t _{RC}	Recall initiation cycle time	25		25		ns	20
t _{NLEL}		NE (bar) set-up	0		0		ns	
t _{GLEL}		Output enable set-up	0		0		ns	
t _{WHEL}		Write enable set-up	0		0		ns	

P10C68 RECALL CYCLE 3 : G (BAR) CONTROLLED (See note 16)

Symbol		Parameter	P10C68-35		P10C68-45		Units	Notes
Standard	Alternative		Min.	Max.	Min.	Max.		
t _{GLQX2}	t _{RECALL}	Recall cycle time		20		20	μs	19
t _{GLNH}	t _{RC}	Recall initiation cycle time	25		25		ns	20
t _{NLGL}		NE (bar) set-up	0		0		ns	
t _{WHGL}		Write enable set-up	0		0		ns	
t _{ELGL}		Chip enable set-up	0		0		ns	

NOTES

- Measured with W (bar) and NE (bar) both returned high, and G (bar) returned low. Address transitions may not occur on any address pin during this time.
- Once t_{RC} has been satisfied by NE (bar), G (bar), W (bar) and E (bar) the RECALL cycle is completed automatically. Any of NE (bar), G (bar) or E (bar) may be used to terminate the RECALL initiation cycle.

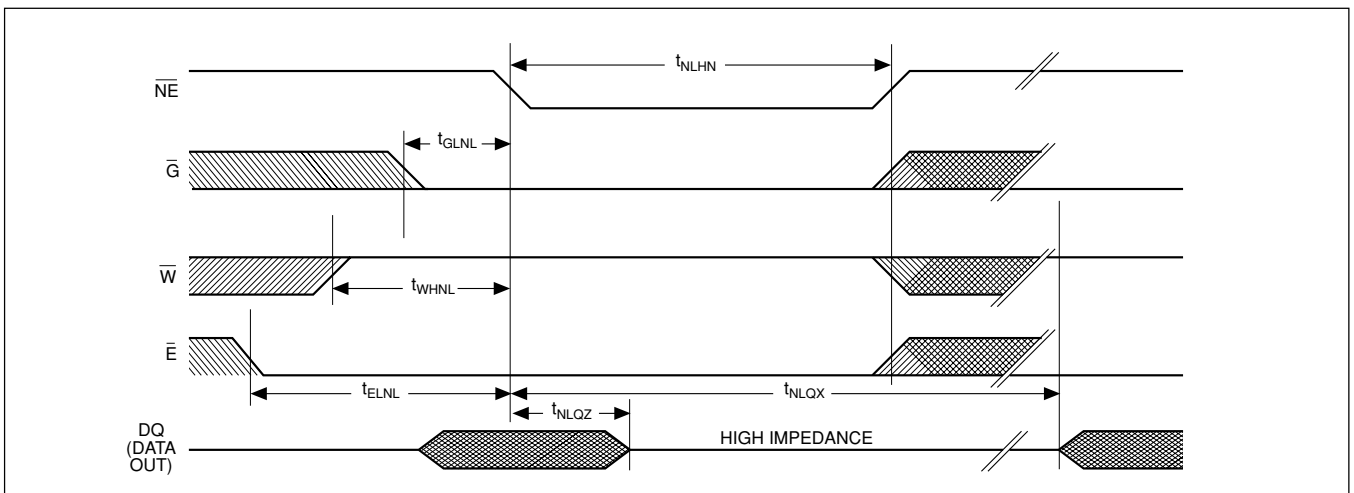

Figure 11. P10C68 RECALL CYCLE 1: NE (bar) controlled timing diagram (see note 16).

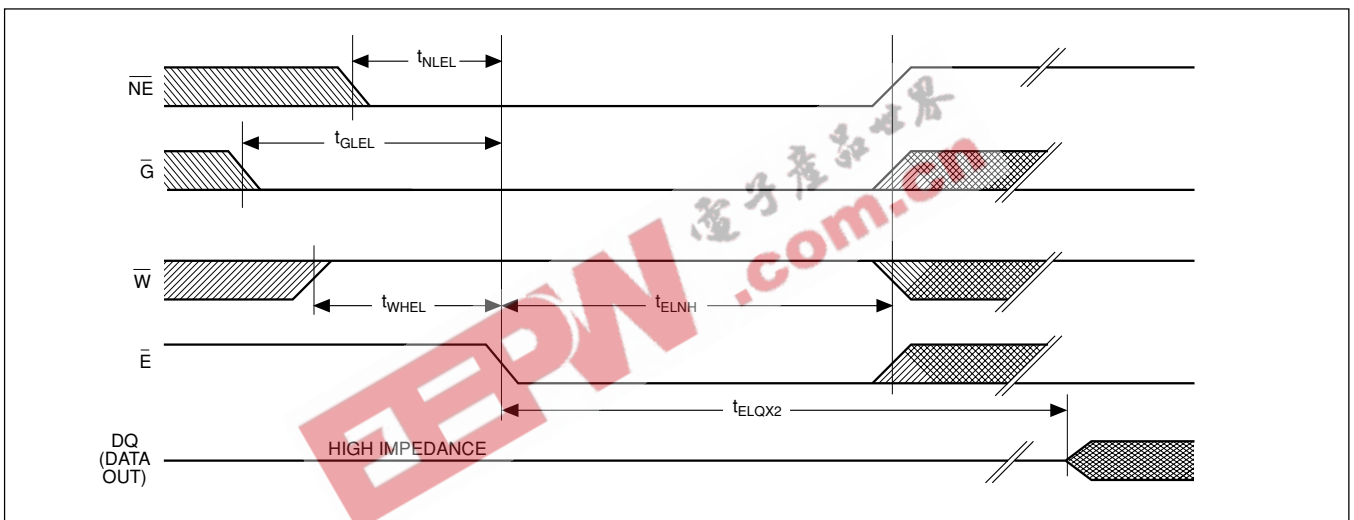

Figure 12. P10C68 RECALL CYCLE 2: E (bar) controlled timing diagram (see note 16).

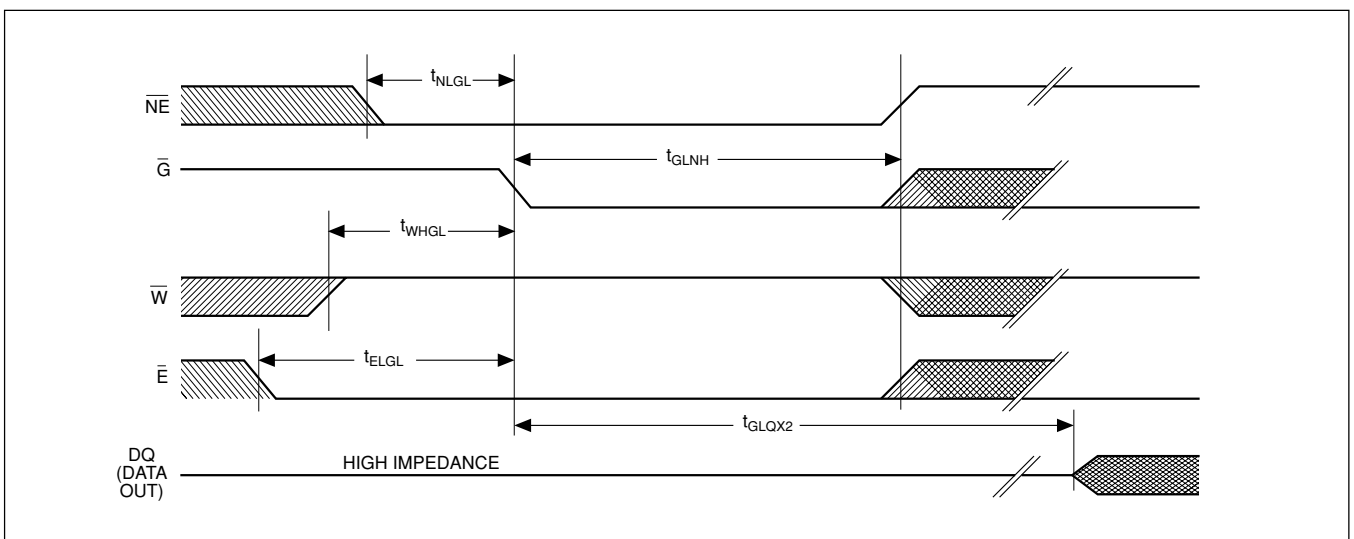

Figure 13. P10C68 RECALL CYCLE 3: E (bar) controlled timing diagram (see note 16).

P10C68/P11C68

NON-VOLATILE MEMORY OPERATION OF P11C68 MODE SELECTION

E	W	A ₁₂ -A ₀ (hex)	Mode	I/O	Power	Notes
H	X	X	Not selected	Output High Z	Standby	
L	H	X	Read RAM	Output data	Active	22
L	L	X	Write RAM	Input Data	Active	
L	H	0000	Read RAM	Output Data	Active	21, 22
		1555	Read RAM	Output Data		21, 22
		0AAA	Read RAM	Output Data		21, 22
		1FFF	Read RAM	Output Data		21, 22
		10F0	Read RAM	Output Data		21, 22
		0F0F	Non-volatile STORE	Output High Z		I _{CC2}
L	H	0000	Read RAM	Output Data	Active	21, 22
		1555	Read RAM	Output Data		21, 22
		0AAA	Read RAM	Output Data		21, 22
		1FFF	Read RAM	Output Data		21, 22
		10F0	Read RAM	Output Data		21, 22
		0F0E	Non-volatile RECALL	Output High Z		

NOTES

- The six consecutive addresses must be in order listed - (0000, 1555, 0AAA, 1FFF, 10F0, 0F0F) for a STORE cycle or (0000, 1555, 0AAA, 1FFF, 10F0, 0F0E) for a RECALL cycle. W (bar) must be high during all six consecutive cycles. See STORE CYCLE and RECALL CYCLE tables and diagrams for further details.
- I/O state assumes that G (bar) $\geq V_{IL}$. Activation of non-volatile cycles does not depend on the state of G (bar).

STORE / RECALL CYCLES 1 AND 2 (See notes 24 and 29)

Symbol		Parameter	P11C68-35		P11C68-45		Units	Notes
Standard	Alternative		Min.	Max.	Min.	Max.		
t _{AVAV}	t _{ACS}	Read cycle time	35		45		ns	
t _{AXAV}	t _{SKEW}	Skew between sequentially adjacent addresses		5		5	ns	23
t _{AVQZ}	t _{ELQZ}	Address valid to output inactive		75		75	ns	25
	t _{STORE}	Store cycle time		10		10	ms	26
	t _{RECALL}	Recall cycle time		20		20	μs	26, 30
t _{AVEL}	t _{AE}	Address set-up to chip enable	0		0		ns	27
t _{ELEH}	t _{EP}	Chip enable pulse width	35		45		ns	27
t _{EHAX}	t _{EA}	Chip disable to address change	0		0		ns	27

NOTES

- Skew spec may be avoided by using E (bar) (STORE/RECALL CYCLE 2).
- W (bar) $\geq V_{IH}$ during entire address sequence to initiate a non-volatile cycle. Required address sequences are shown in the Mode Selection table.
- Once the software STORE or RECALL cycle is initiated, it completes automatically, ignoring all inputs.
- Measured with W (bar) high, G (bar) low and E (bar) low. Note that STORE cycles (but not RECALLS) are aborted by V_{CC} < 3.3V (STORE Inhibit).
- E (bar) must make the transition between V_{IH}(max) to V_{IL}(max), or V_{IL}(max) to V_{IH}(min) in a monotonic fashion.
- Chip is continuously selected with E (bar) low.
- Addresses 1 through 6 are found in the Mode Selection table. Address 6 determines whether the P11C68 performs a STORE or RECALL. A RECALL cycle is performed automatically at power up when V_{CC} exceeds 3.3V. V_{CC} must not drop below 3.3V once it has exceeded it for the RECALL to function properly, t_{RECALL} is measured from the point at which V_{CC} exceeds 3.3V.
- Address transitions may not occur on any address pin during this time.

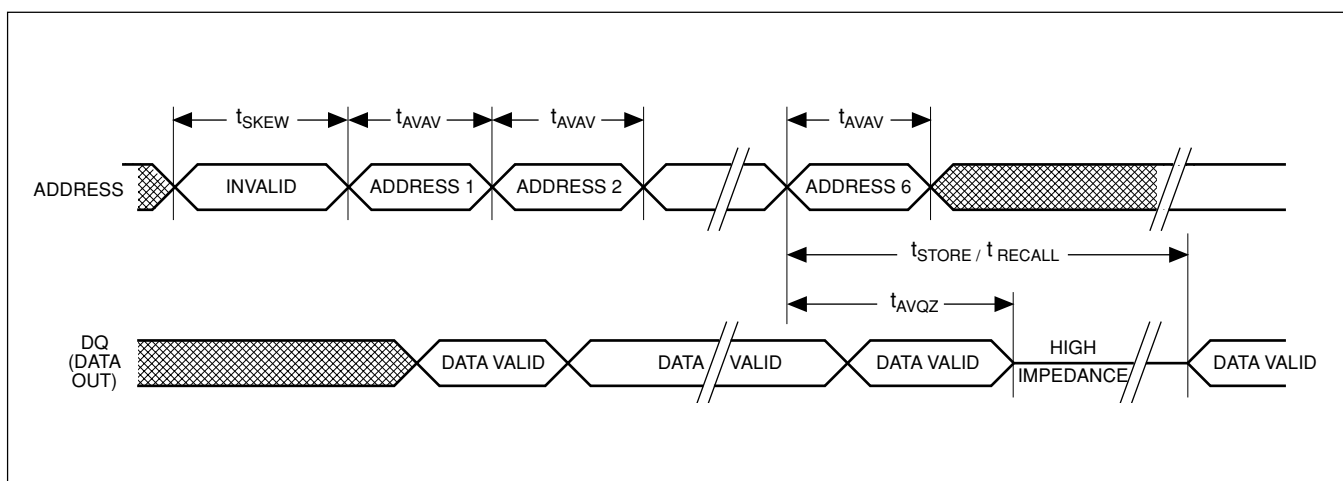

Figure 14. STORE/RECALL cycle 1. Address controlled timing diagram (see notes 22, 26 and 27).

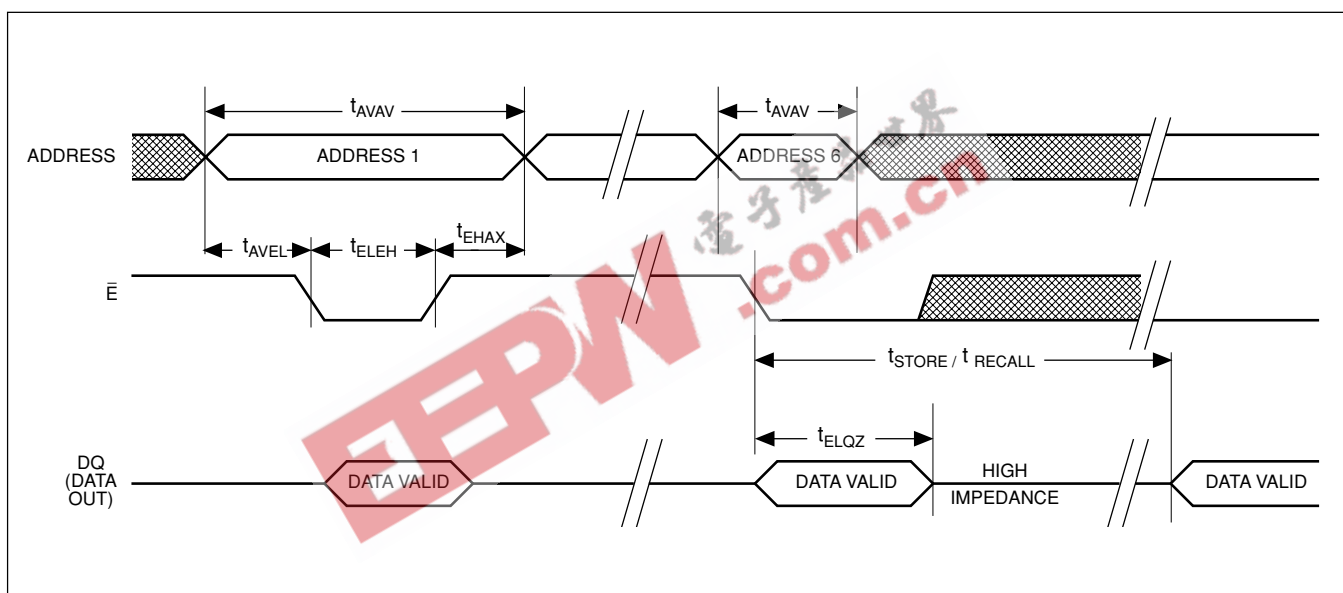

Figure 15. STORE/RECALL cycle 2. E (bar) controlled timing diagram (see notes 22, 25 and 27).

OPERATING NOTES

Note: References to NE (bar) should be taken as applying to P10C68 only and can be ignored for P11C68.

The devices have two separate modes of operation: SRAM mode and non-volatile mode. In SRAM mode, the memory operates as an ordinary static RAM. While in non-volatile mode, data is transferred in parallel from SRAM to EEPROM or from EEPROM to SRAM.

SRAM READ

The devices perform a read cycle when ever E (bar) and G (bar) are LOW and NE (bar) and W (bar) are HIGH. The address specified by the thirteen address pins A_{0-12} determine which of the 8192 data bytes will be accessed. When the READ is initiated by an address transition, the outputs will be valid after a delay of t_{AVQV} (READ CYCLE 1).

If the READ is initiated by E (bar) or G (bar), the outputs will be valid at t_{ELQV} or t_{GLQV} , whichever is later. (READ CYCLE 2). The data outputs will repeatedly respond to address changes within the t_{AVQV} access time without the need for transitions on any control input pins and will remain valid until another address change or until E (bar) or G (bar) is brought HIGH or W (bar) or NE (bar) is brought LOW.

SRAM WRITE

A write cycle is performed whenever E (bar) and W (bar) are LOW and NE (bar) is HIGH. The address inputs must be stable prior to entering the WRITE cycle and must remain stable until either E (bar) or W (bar) go HIGH at the end of the cycle. The data on the eight pins DQ_{0-7} , will be written into the memory location specified by the address inputs if valid t_{DVWH} before the end of a W (bar) controlled WRITE or t_{DVEH} before the end of an E (bar) controlled WRITE.

P10C68/P11C68

It is recommended that G (bar) be kept HIGH during the entire WRITE cycle to avoid data bus contention on the common I/O lines. If G (bar) is left LOW, internal circuitry will turn off the output buffers t_{WHQZ} after W (bar) goes LOW.

Non-Volatile STORE - P10C68

A STORE cycle is performed when NE, (bar) E (bar) and W (bar) are LOW and G (bar) is HIGH. While any sequence to achieve this state will initiate a STORE, only W(bar) initiation (STORE CYCLE 1) and E (bar) initiation (STORE CYCLE 2) are practical without risking an unintentional SRAM WRITE that would disturb SRAM data. During the STORE cycle, previous non-volatile data is erased and the SRAM contents are then programmed into non-volatile elements. Once a STORE cycle is initiated, further input and output is disabled and the DQ₀₋₇ pins are tri-stated until the cycle is completed.

If E (bar) and G (bar) are LOW and W (bar) and NE (bar) are HIGH at the end of the cycle, a READ will be performed and the outputs will go active, signalling the end of the STORE.

The P10C68 will not be activated into either a STORE or RECALL cycle by the software sequence required for the P11C68.

Hardware Protect - P10C68

The P10C68 offers two levels of protection to suppress inadvertent STORE cycles. If the clock signals remain in the STORE condition at the end of a STORE cycle, a second STORE cycle will not be started. The STORE will be initiated only after a HIGH to LOW transition on NE (bar) Because the STORE cycle is initiated by an NE (bar) transition, powering-up the chip with NE (bar) Low will not initiate a STORE cycle either.

In addition to multi-trigger protection, the P10C68 offers hardware protection through Vcc Sense. A STORE cycle will not be initiated, and one in progress will discontinue, if Vcc goes below 3.3V.

Non-Volatile RECALL - P10C68

A RECALL cycle is performed when E (bar), G (bar) and NE (bar) are LOW and W (bar) is HIGH. Like the STORE cycle, RECALL is initiated when the last of the four clock signals goes to the RECALL state. Once initiated, the RECALL cycle will take t_{NLQX} to complete, during which all inputs are ignored. When the RECALL completes, any READ or WRITE state on the input pins will take effect.

Internally, RECALL is a two step procedure. First the SRAM data is cleared and second, the non-volatile information is transferred into the SRAM cells. The RECALL operation in no way alters the data in the non-volatile cells. The non-volatile data can be recalled an unlimited number of times. Address transitions may not occur during the RECALL cycle. Like the STORE cycle, a transition must occur on the NE (bar) pin to cause a RECALL, preventing inadvertent multi-triggering. On power-up, once Vcc exceeds Vcc sense voltage of 3.3V, a RECALL cycle is automatically initiated. The voltage on the Vcc pin must not drop below 3.3V once it has risen above it in order for the RECALL to operate properly. Due to the automatic RECALL, SRAM operation cannot commence until t_{NLQX} after Vcc exceeds 3.3V.

The P11C68 STORE cycle is initiated by executing sequential READ cycles from six specific address locations. By relying on READ cycles only, the P11C68 implements non-volatile operation while remaining pin-for-pin compatible with standard 8Kx8 SRAMs. During the STORE cycle, an erase of the previous non-volatile data is first performed, followed by a program of the non-volatile elements. The program operation copies the SRAM data into non-volatile storage. Once a STORE cycle is initiated, further input and output are disabled until the cycle is completed. Because a sequence of addresses is used for STORE initiation, it is critical that no invalid address states intervene in the sequence or the sequence will be aborted. The maximum skew between address inputs A0-12 for each address state is t_{SKEW} (STORE CYCLE 1).

If t_{SKEW} is exceeded it is possible that the transitional data state will be interpreted as a valid address and the sequence will be aborted. If E (bar) controlled READ cycles are used for the sequence (STORE CYCLE 2), address skew is no longer a concern.

To enable the STORE cycle the following READ sequence must be performed.

1. Read address 0000 (hex) Valid READ
2. Read address 1555 (hex) Valid READ
3. Read address 0AAA (hex) Valid READ
4. Read address 1FFF (hex) Valid READ
5. Read address 10F0 (hex) Valid READ
6. Read address 0F0F (hex) Initiate STORE Cycle

Once the sixth address in the sequence has been entered, the STORE cycle will commence and the chip will be disabled. It is important that READ cycles and not WRITE cycles be used in the sequence, although it is not necessary that G (bar) be LOW for the sequence to be valid. After the t_{STORE} cycle time has been fulfilled, the SRAM will again be activated for READ and WRITE operation.

Once the first of the six reads has taken place, the read sequence must either complete or terminate with an incorrect address (other than 0000 hex) before it may be started anew.

The P11C68 offers hardware protection against inadvertent STORE cycles through Vcc Sense. A STORE cycle will not be initiated, and one in progress will discontinue, if Vcc goes below 3.3V.

A RECALL of the EEPROM data into the SRAM is initiated with a sequence of READ operations in a manner similar to the STORE initiation. To initiate the RECALL cycle the following sequence of READ operations must be performed:

1. Read address 0000 (hex) Valid READ
2. Read address 1555 (hex) Valid READ
3. Read address 0AAA (hex) Valid READ
4. Read address 1FFF (hex) Valid READ
5. Read address 10F0 (hex) Valid READ
6. Read address 0F0E (hex) Initiate RECALL Cycle

Internally, RECALL is a two step procedure. First, the SRAM data is cleared and second the non-volatile information is transferred into the SRAM cells. The RECALL operation in no way alters the data in the EEPROM cells. The non-volatile data can be recalled an unlimited number of times. Address transitions may not occur during the RECALL cycle.

On power-up, once V_{CC} exceeds the V_{CC} sense voltage of 3.3V, a RECALL cycle is automatically initiated. The voltage on the V_{CC} pin must not drop below 3.3V once it has risen above it in order for the RECALL to operate properly. Due to this automatic RECALL, SRAM operation cannot commence until t_{RECALL} after V_{CC} exceeds 3.3V.

The automatic RECALL feature can be adversely affected by factors such as supply rise time, temperature and elapsed time since the last STORE cycle. For this reason it is recommended that the user initiate a RECALL cycle after power-up for critical applications.

PACKAGE DETAILS

Dimensions are shown thus: mm (in). For further package information please contact your local Customer Service Centre.

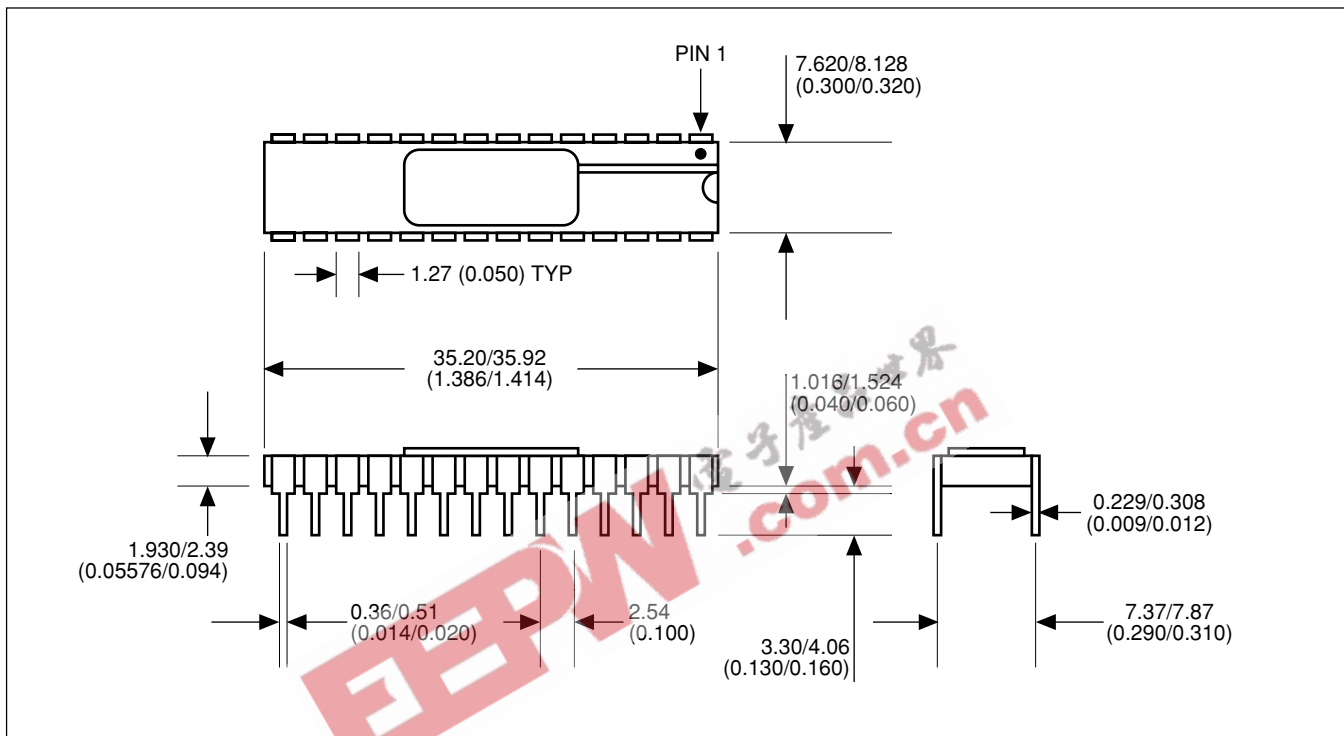

Figure 16, 28-lead sidebrazed ceramic DIL (0.3in) DCB

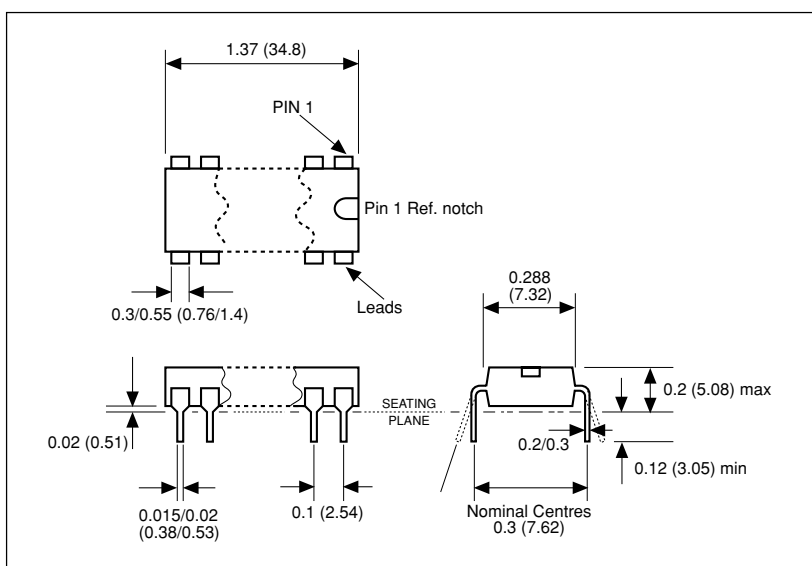
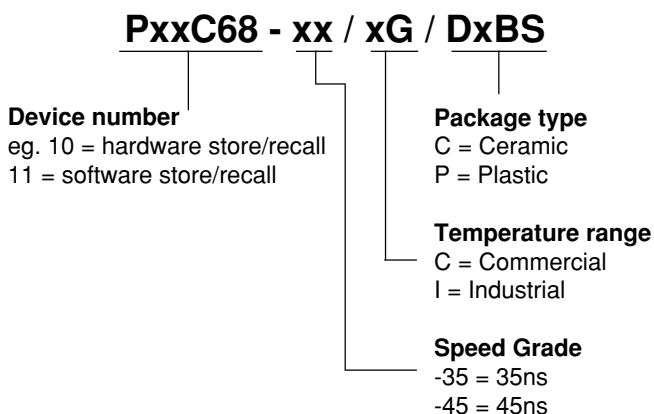

Figure 17, 28 plastic DIL Package (0.3in) DPB

P10C68/P11C68

ORDERING INFORMATION



EEPW 电子产品世界 .com.cn



HEADQUARTERS OPERATIONS
GEC PLESSEY SEMICONDUCTORS
Cheney Manor, Swindon,
Wiltshire SN2 2QW, United Kingdom.
Tel: (0793) 518000 Tx: 449637
Fax: (0793) 518411

GEC PLESSEY SEMICONDUCTORS
Sequoia Research Park, 1500 Green Hills Road,
Scotts Valley, California 95066,
United States of America. Tel (408) 438 2900
ITT Telex: 4940840 Fax: (408) 438 5576

CUSTOMER SERVICE CENTRES

- **FRANCE & BENELUX** Les Ulis Cedex Tel: (1) 64 46 23 45 Tx: 602858F
Fax : (1) 64 46 06 07
 - **GERMANY** Munich Tel: (089) 3609 06-0 Tx: 523980 Fax : (089) 3609 06-55
 - **ITALY** Milan Tel: (02) 66040867 Fax: (02) 66040993
 - **JAPAN** Tokyo Tel: (03) 3296-0281 Fax: (03) 3296-0228
 - **NORTH AMERICA Integrated Circuits and Microwave Products**, Scotts Valley, USA
Tel (408) 438 2900 ITT Tx: 4940840 Fax: (408) 438 7023.
Hybrid Products, Farmingdale, USA Tel (516) 293 8686
Fax: (516) 293 0061.
 - **SOUTH EAST ASIA** Singapore Tel: 2919291 Fax: 2916455
 - **SWEDEN** Johanneshov Tel: 46 8 702 97 70 Fax: 46 8 640 47 36
 - **UNITED KINGDOM & SCANDINAVIA**
Swindon Tel: (0793) 518510 Tx: 444410 Fax : (0793) 518582
- These are supported by Agents and Distributors in major countries world-wide.

© GEC Plessey Semiconductors Year Publication No. XX XXXX Issue No. X.X Month Year

This publication is issued to provide information only which (unless agreed by the Company in writing) may not be used, applied or reproduced for any purpose nor form part of any order or contract nor to be regarded as a representation relating to the products or services concerned. No warranty or guarantee express or implied is made regarding the capability, performance or suitability of any product or service. The Company reserves the right to alter without prior knowledge the specification, design or price of any product or service. Information concerning possible methods of use is provided as a guide only and does not constitute any guarantee that such methods of use will be satisfactory in a specific piece of equipment. It is the user's responsibility to fully determine the performance and suitability of any equipment using such information and to ensure that any publication or data used is up to date and has not been superseded. These products are not suitable for use in any medical products whose failure to perform may result in significant injury or death to the user. All products and materials are sold and services provided subject to the Company's conditions of sale, which are available on request.



**For more information about all Zarlink products
visit our Web Site at**

www.zarlink.com

Information relating to products and services furnished herein by Zarlink Semiconductor Inc. trading as Zarlink Semiconductor or its subsidiaries (collectively "Zarlink") is believed to be reliable. However, Zarlink assumes no liability for errors that may appear in this publication, or for liability otherwise arising from the application or use of any such information, product or service or for any infringement of patents or other intellectual property rights owned by third parties which may result from such application or use. Neither the supply of such information or purchase of product or service conveys any license, either express or implied, under patents or other intellectual property rights owned by Zarlink or licensed from third parties by Zarlink, whatsoever. Purchasers of products are also hereby notified that the use of product in certain ways or in combination with Zarlink, or non-Zarlink furnished goods or services may infringe patents or other intellectual property rights owned by Zarlink.

This publication is issued to provide information only and (unless agreed by Zarlink in writing) may not be used, applied or reproduced for any purpose nor form part of any order or contract nor to be regarded as a representation relating to the products or services concerned. The products, their specifications, services and other information appearing in this publication are subject to change by Zarlink without notice. No warranty or guarantee express or implied is made regarding the capability, performance or suitability of any product or service. Information concerning possible methods of use is provided as a guide only and does not constitute any guarantee that such methods of use will be satisfactory in a specific piece of equipment. It is the user's responsibility to fully determine the performance and suitability of any equipment using such information and to ensure that any publication or data used is up to date and has not been superseded. Manufacturing does not necessarily include testing of all functions or parameters. These products are not suitable for use in any medical products whose failure to perform may result in significant injury or death to the user. All products and materials are sold and services provided subject to Zarlink's conditions of sale which are available on request.

Purchase of Zarlink's I²C components conveys a licence under the Philips I²C Patent rights to use these components in an I²C System, provided that the system conforms to the I²C Standard Specification as defined by Philips.

Zarlink and the Zarlink Semiconductor logo are trademarks of Zarlink Semiconductor Inc.

Copyright 2001, Zarlink Semiconductor Inc. All Rights Reserved.

TECHNICAL DOCUMENTATION - NOT FOR RESALE
