

P4C164

ULTRA HIGH SPEED 8K x 8

STATIC CMOS RAMS



FEATURES

- Full CMOS, 6T Cell
- High Speed (Equal Access and Cycle Times)
 - 8/10/12/15/20/25/35/70/100 ns (Commercial)
 - 10/12/15/20/25/35/70/100 ns (Industrial)
 - 12/15/20/25/35/45/70/100 ns (Military)
- Low Power Operation
- Output Enable and Dual Chip Enable Control Functions
- Single 5V±10% Power Supply
- Data Retention with 2.0V Supply, 10 µA Typical Current (P4C164L Military)
- Common Data I/O
- Fully TTL Compatible Inputs and Outputs
- Standard Pinout (JEDEC Approved)
 - 28-Pin 300 mil Plastic DIP, SOJ
 - 28-Pin 600 mil Plastic DIP (70 & 100ns)
 - 28-Pin 300 mil SOP (70 & 100ns)
 - 28-Pin 300 mil Ceramic DIP
 - 28-Pin 600 mil Ceramic DIP
 - 28-Pin 350 x 550 mil LCC
 - 32-Pin 450 x 550 mil LCC
 - 28-Pin CERPACK



DESCRIPTION

The P4C164 is a 65,536-bit ultra high-speed static RAM organized as 8K x 8. The CMOS memory requires no clocks or refreshing and has equal access and cycle times. Inputs are fully TTL-compatible. The RAM operates from a single 5V±10% tolerance power supply. With battery backup, data integrity is maintained with supply voltages down to 2.0V. Current drain is typically 10 µA from a 2.0V supply.

Access times as fast as 8 nanoseconds are available, permitting greatly enhanced system operating speeds.

The P4C164 is available in 28-pin 300 mil DIP and SOJ, 28-pin 600 mil plastic and ceramic DIP, 28-pin 350 x 550 mil LCC, 32-pin 450 x 550 mil LCC, and 28-pin CERPACK. The 70ns and 100ns P4C164s are available in the 600 mil plastic DIP.



FUNCTIONAL BLOCK DIAGRAM

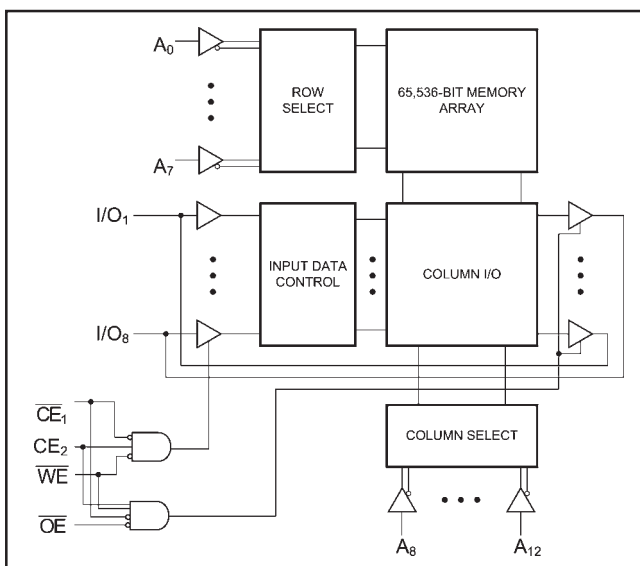

PIN CONFIGURATIONS

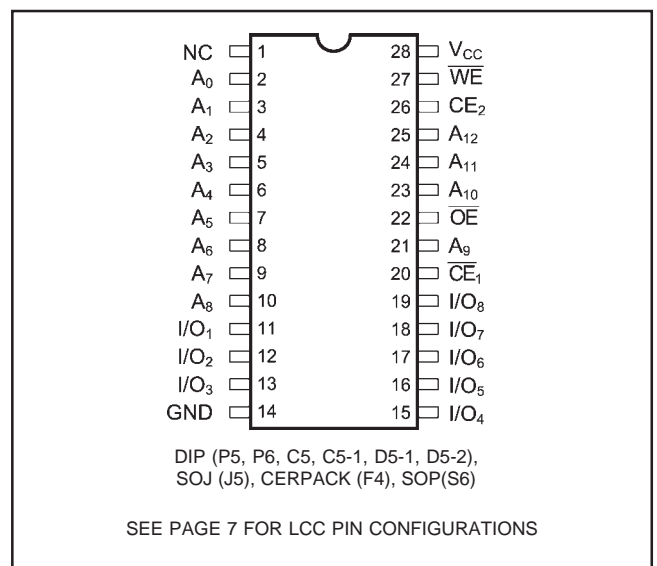

MAXIMUM RATINGS⁽¹⁾

Symbol	Parameter	Value	Unit
V _{CC}	Power Supply Pin with Respect to GND	-0.5 to +7	V
V _{TERM}	Terminal Voltage with Respect to GND (up to 7.0V)	-0.5 to V _{CC} +0.5	V
T _A	Operating Temperature	-55 to +125	°C

Symbol	Parameter	Value	Unit
T _{BIAS}	Temperature Under Bias	-55 to +125	°C
T _{STG}	Storage Temperature	-65 to +150	°C
P _T	Power Dissipation	1.0	W
I _{OUT}	DC Output Current	50	mA

RECOMMENDED OPERATING TEMPERATURE AND SUPPLY VOLTAGE

Grade ⁽²⁾	Ambient Temperature	GND	V _{CC}
Military	-55°C to +125°C	0V	5.0V ± 10%
Industrial	-40°C to +85°C	0V	5.0V ± 10%
Commercial	0°C to +70°C	0V	5.0V ± 10%

CAPACITANCES⁽⁴⁾

V_{CC} = 5.0V, T_A = 25°C, f = 1.0MHz

Symbol	Parameter	Conditions	Typ.	Unit
C _{IN}	Input Capacitance	V _{IN} = 0V	5	pF
C _{OUT}	Output Capacitance	V _{OUT} = 0V	7	pF

DC ELECTRICAL CHARACTERISTICS

Over recommended operating temperature and supply voltage⁽²⁾

Symbol	Parameter	Test Conditions	P4C164		P4C164L		Unit
			Min	Max	Min	Max	
V _{IH}	Input High Voltage		2.2	V _{CC} +0.5	2.2	V _{CC} +0.5	V
V _{IL}	Input Low Voltage		-0.5 ⁽³⁾	0.8	-0.5 ⁽³⁾	0.8	V
V _{HC}	CMOS Input High Voltage		V _{CC} -0.2	V _{CC} +0.5	V _{CC} -0.2	V _{CC} +0.5	V
V _{LC}	CMOS Input Low Voltage		-0.5 ⁽³⁾	0.2	-0.5 ⁽³⁾	0.2	V
V _{CD}	Input Clamp Diode Voltage	V _{CC} = Min., I _{IN} = -18 mA		-1.2		-1.2	V
V _{OL}	Output Low Voltage (TTL Load)	I _{OL} = +8 mA, V _{CC} = Min.		0.4		0.4	V
V _{OH}	Output High Voltage (TTL Load)	I _{OH} = -4 mA, V _{CC} = Min.	2.4		2.4		V
I _{IU}	Input Leakage Current	V _{CC} = Max. Mil. V _{IN} = GND to V _{CC} Ind./Com'l.	-10 -5	+10 +5	-5 n/a	+5 n/a	µA
I _{LO}	Output Leakage Current	V _{CC} = Max., $\overline{CE} = V_{IH}$, Mil. V _{OUT} = GND to V _{CC} Ind./Com'l.	-10 -5	+10 +5	-5 n/a	+5 n/a	µA
I _{SB}	Standby Power Supply Current (TTL Input Levels)	$\overline{CE}_1 \geq V_{IH}$ or Mil. $\overline{CE}_2 \leq V_{IL}$, Ind./Com'l. V _{CC} = Max, f = Max., Outputs Open	— —	40 30	— —	40 n/a	mA
I _{SB1}	Standby Power Supply Current (CMOS Input Levels)	$\overline{CE}_1 \geq V_{HC}$ or Mil. $\overline{CE}_2 \leq V_{LC}$, Ind./Com'l. V _{CC} = Max, f = 0, Outputs Open V _{IN} ≤ V _{LC} or V _{IN} ≥ V _{HC}	— —	25 15	— —	1 n/a	mA

Notes:

1. Stresses greater than those listed under MAXIMUM RATINGS may cause permanent damage to the device. This is a stress rating only and functional operation of the device at these or any other conditions above those indicated in the operational sections of this specification is not implied. Exposure to MAXIMUM rating conditions for extended periods may affect reliability.
2. Extended temperature operation guaranteed with 400 linear feet per minute of air flow.
3. Transient inputs with V_{IL} and I_{IL} not more negative than -3.0V and -100mA, respectively, are permissible for pulse widths up to 20ns.
4. This parameter is sampled and not 100% tested.

POWER DISSIPATION CHARACTERISTICS VS. SPEED

Symbol	Parameter	Temperature Range	-8	-10	-12	-15	-20	-25	-35	45	-70	-100	Unit
I _{CC}	Dynamic Operating Current*	Commercial	200	180	170	160	155	150	145	N/A	130	125	mA
		Industrial	N/A	190	180	170	160	155	150	N/A	145	140	mA
		Military	N/A	N/A	180	170	160	155	150	145	145	145	mA

*V_{CC} = 5.5V. Tested with outputs open. f = Max. Switching inputs are 0V and 3V. $\overline{CE}_1 = V_{IL}$, CE₂ = V_{IH}, $\overline{OE} = V_{IH}$

DATA RETENTION CHARACTERISTICS (P4C164L, Military Temperature Only)

Symbol	Parameter	Test Condition	Min	Typ.*		Max		Unit
				V _{CC} = 2.0V	V _{CC} = 3.0V	V _{CC} = 2.0V	V _{CC} = 3.0V	
V _{DR}	V _{CC} for Data Retention		2.0					V
I _{CCDR}	Data Retention Current	$\overline{CE}_1 \geq V_{CC} - 0.2V$ or CE ₂ ≤ 0.2V, V _{IN} ≥ V _{CC} - 0.2V or V _{IN} ≤ 0.2V		10	15	200	300	μA
t _{CDR}	Chip Deselect to Data Retention Time		0					ns
t _R [†]	Operation Recovery Time		t _{RC} [§]					ns

*T_A = +25°C

§t_{RC} = Read Cycle Time

†This parameter is guaranteed but not tested.

DATA RETENTION WAVEFORM

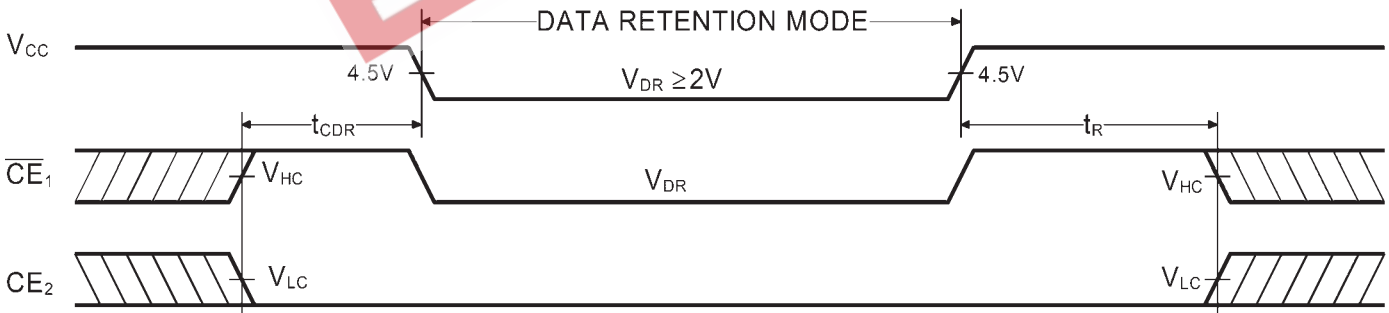

AC ELECTRICAL CHARACTERISTICS—READ CYCLE

($V_{CC} = 5V \pm 10\%$, All Temperature Ranges)⁽²⁾

Symbol	Parameter	-8		-10		-12		-15		-20		-25		-35		-45		-70		-100		Unit
		Min	Max	Min	Max	Min	Max	Min	Max	Min	Max	Min	Max	Min	Max	Min	Max	Min	Max	Min	Max	
t_{RC}	Read Cycle Time	8		10		12		15		20		25		35		45		70		100		ns
t_{AA}	Address Access Time		8		10		12		15		20		25		35		45		70		100	ns
t_{AC}	Chip Enable Access Time		8		10		12		15		20		25		35		45		70		100	ns
t_{OH}	Output Hold from Address Change	3		3		3		3		3		3		3		3		3		3		ns
t_{LZ}	Chip Enable to Output in Low Z	2		2		2		2		2		2		2		2		2		2		ns
t_{HZ}	Chip Disable to Output in High Z		5		6		7		8		8		10		15		20		35		45	ns
t_{OE}	Output Enable Low to Data Valid		5		6		7		9		10		13		18		20		35		45	ns
t_{OLZ}	Output Enable Low to Low Z	2		2		2		2		2		2		2		2		2		2		ns
t_{OHZ}	Output Enable High to High Z		5		6		7		9		9		12		15		20		35		45	ns
t_{PU}	Chip Enable to Power Up Time	0		0		0		0		0		0		0		0		0		0		ns
t_{PD}	Chip Disable to Power Down Time		8		10		12		15		20		20		20		25		35		45	ns

TIMING WAVEFORM OF READ CYCLE NO. 1 (\overline{OE} CONTROLLED)⁽⁵⁾

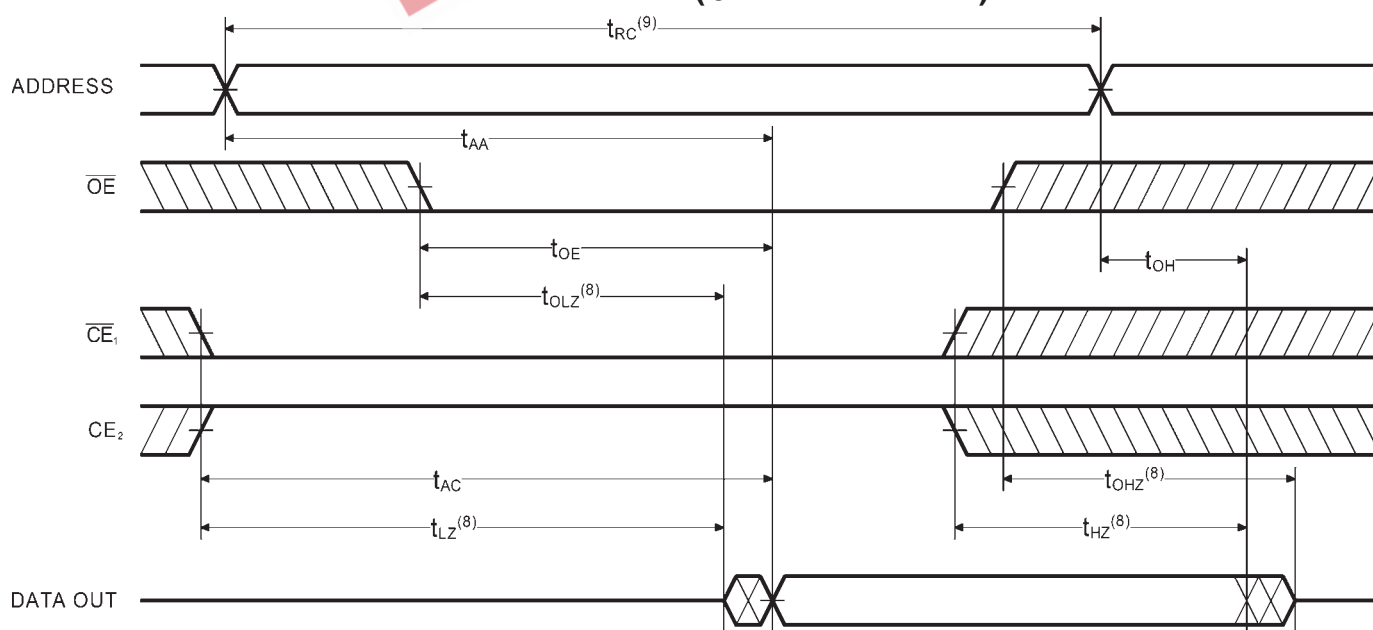

Notes:

- 5. \overline{WE} is HIGH for READ cycle.
- 6. \overline{CE}_1 is LOW, \overline{CE}_2 is HIGH and \overline{OE} is LOW for READ cycle.
- 7. ADDRESS must be valid prior to, or coincident with \overline{CE}_1 transition LOW and \overline{CE}_2 transition HIGH.

- 8. Transition is measured ± 200 mV from steady state voltage prior to change, with loading as specified in Figure 1. This parameter is sampled and not 100% tested.

TIMING WAVEFORM OF READ CYCLE NO. 2 (ADDRESS CONTROLLED)^(5,6)

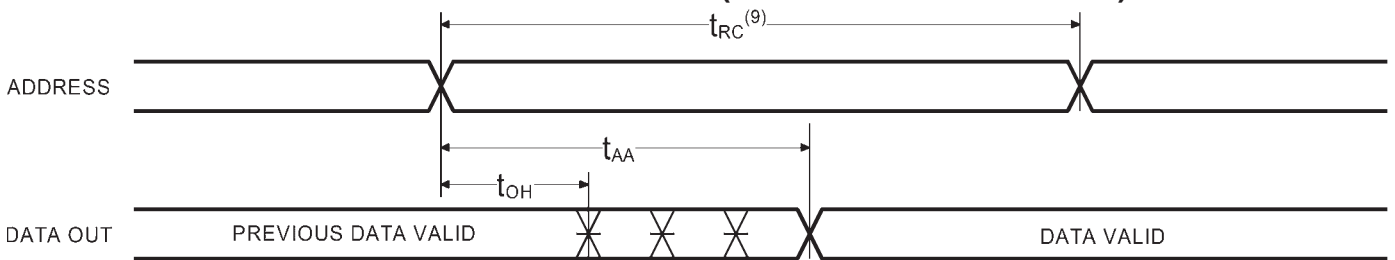

TIMING WAVEFORM OF READ CYCLE NO. 3 (\overline{CE}_1 , CE_2 CONTROLLED)^(5,7,10)

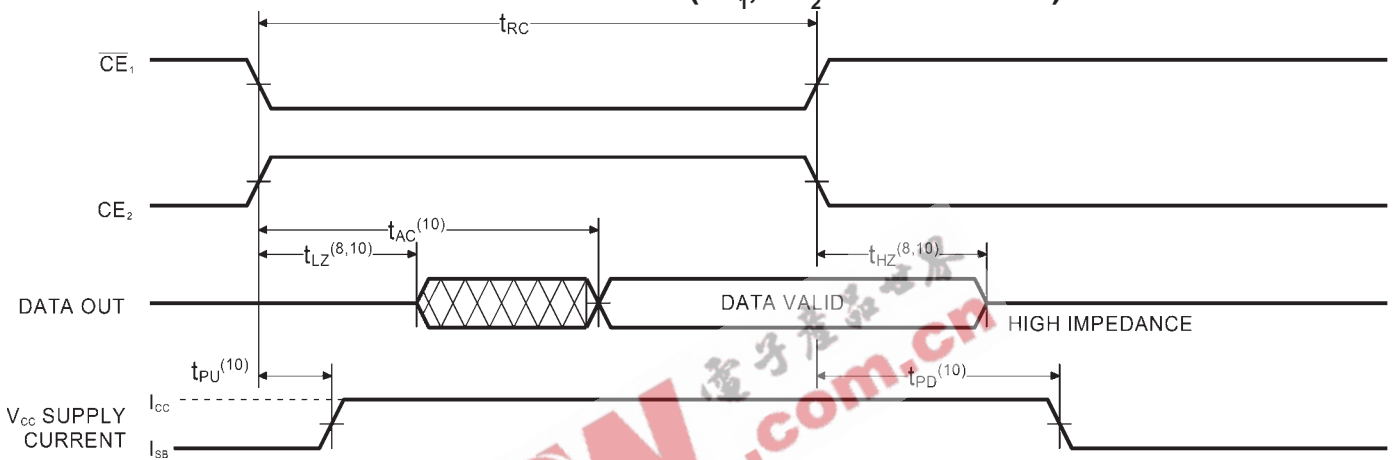

Notes:

9. READ Cycle Time is measured from the last valid address to the first transitioning address.

10. Transitions caused by a chip enable control have similar delays irrespective of whether \overline{CE}_1 or CE_2 causes them.

AC CHARACTERISTICS—WRITE CYCLE

($V_{CC} = 5V \pm 10\%$, All Temperature Ranges)⁽²⁾

Symbol	Parameter	-8		-10		-12		-15		-20		-25		-35		-45		-70		-100		Unit
		Min	Max	Min	Max	Min	Max	Min	Max	Min	Max	Min	Max	Min	Max	Min	Max	Min	Max	Min	Max	
t_{WC}	Write Cycle Time	8		10		12		15		20		25		35		45		70		100		ns
t_{CW}	Chip Enable Time to End of Write	6		7		8		12		15		18		25		33		50		70		ns
t_{AW}	Address Valid to End of Write	7		8		10		12		15		18		25		33		50		70		ns
t_{AS}	Address Set-up Time	0		0		0		0		0		0		0		0		0		0		ns
t_{WP}	Write Pulse Width	7		8		9		12		15		18		20		25		40		50		ns
t_{AH}	Address Hold Time	0		0		0		0		0		0		0		0		0		0		ns
t_{DW}	Data Valid to End of Write	6		7		8		9		11		13		15		20		30		40		ns
t_{DH}	Date Hold Time	0		0		0		0		0		0		0		0		0		0		ns
t_{WZ}	Write Enable to Output in High Z		6		7		7		7		8		10		14		18		30		40	ns
t_{OW}	Output Active from End of Write	3		3		3		3		3		3		3		3		3		3		ns

TIMING WAVEFORM OF WRITE CYCLE NO. 1 (\overline{WE} CONTROLLED)⁽¹¹⁾

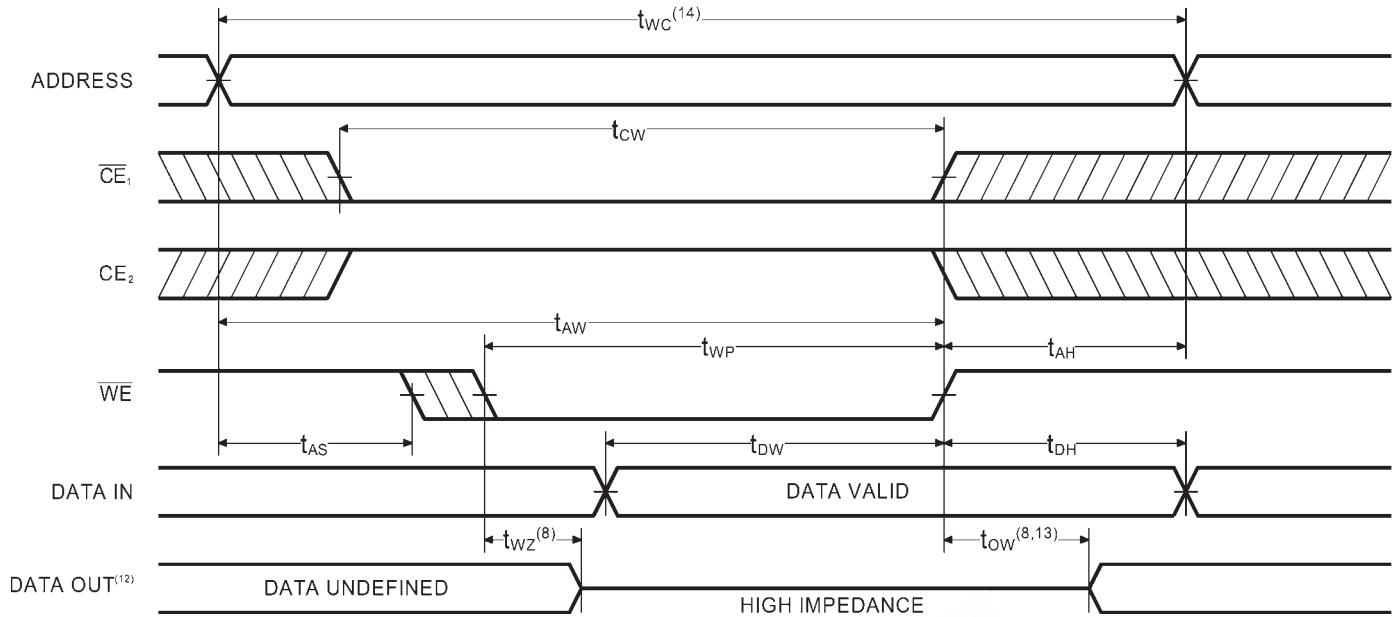

TIMING WAVEFORM OF WRITE CYCLE NO. 2 (\overline{CE} CONTROLLED)⁽¹¹⁾

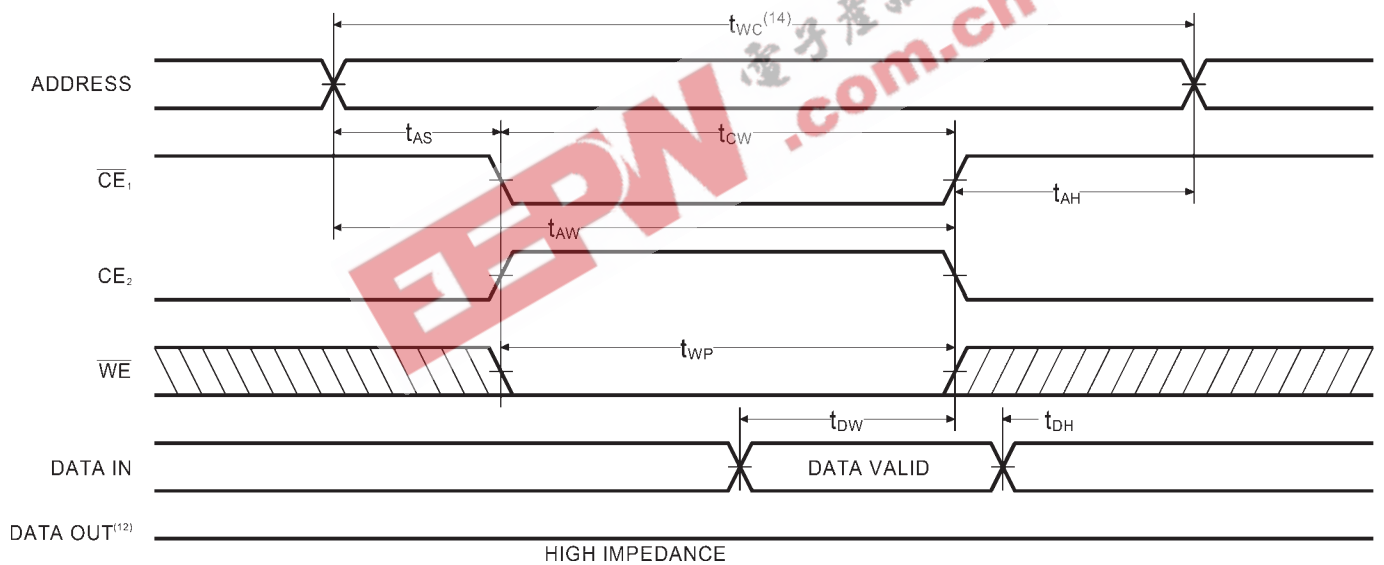

Notes:

- 11. \overline{CE}_1 and \overline{WE} must be LOW, and CE_2 HIGH for WRITE cycle.
- 12. \overline{OE} is LOW for this WRITE cycle to show t_{WZ} and t_{OW} .
- 13. If \overline{CE}_1 goes HIGH, or CE_2 goes LOW, simultaneously with \overline{WE} HIGH, the output remains in a high impedance state.
- 14. Write Cycle Time is measured from the last valid address to the first transitioning address.

AC TEST CONDITIONS

Input Pulse Levels	GND to 3.0V
Input Rise and Fall Times	3ns
Input Timing Reference Level	1.5V
Output Timing Reference Level	1.5V
Output Load	See Figures 1 and 2

TRUTH TABLE

Mode	\overline{CE}_1	CE_2	\overline{OE}	\overline{WE}	I/O	Power
Standby	H	X	X	X	High Z	Standby
Standby	X	L	X	X	High Z	Standby
D_{OUT} Disabled	L	H	H	H	High Z	Active
Read	L	H	L	H	D_{OUT}	Active
Write	L	H	X	L	High Z	Active

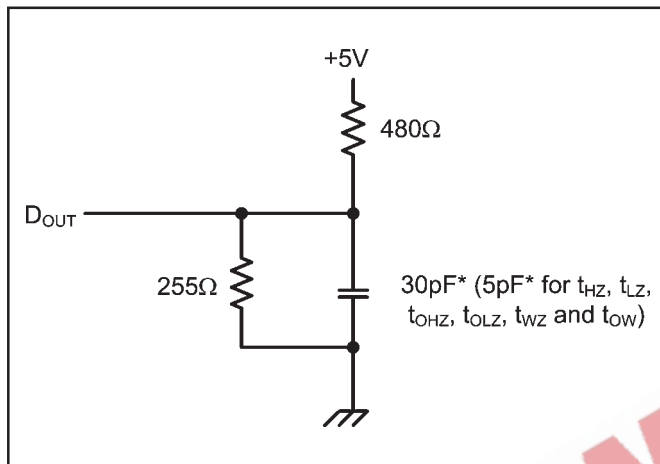

Figure 1. Output Load

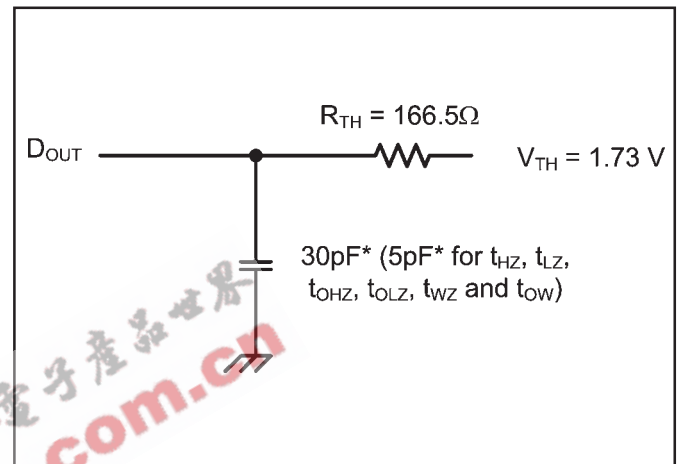

Figure 2. Thevenin Equivalent

* including scope and test fixture.

Note:

Because of the high speed of the P4C164/L, care must be taken when testing this device; an inadequate setup can cause a normal functioning part to be rejected as faulty. Long high-inductance leads that cause supply bounce must be avoided by bringing the V_{CC} and ground planes directly up to the contactor fingers. A 0.01 μ F high frequency capacitor is also required between V_{CC} and ground. To avoid signal reflections,

proper termination must be used; for example, a 50 Ω test environment should be terminated into a 50 Ω load with 1.73V (Thevenin Voltage) at the comparator input, and a 116 Ω resistor must be used in series with D_{OUT} to match 166 Ω (Thevenin Resistance).

LCC PIN CONFIGURATIONS

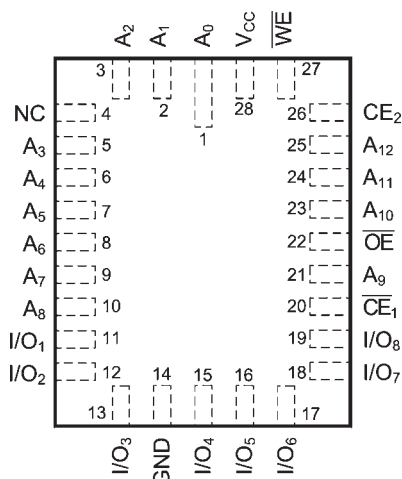

LCC (L5)
"L" - STANDARD PIN-OUT

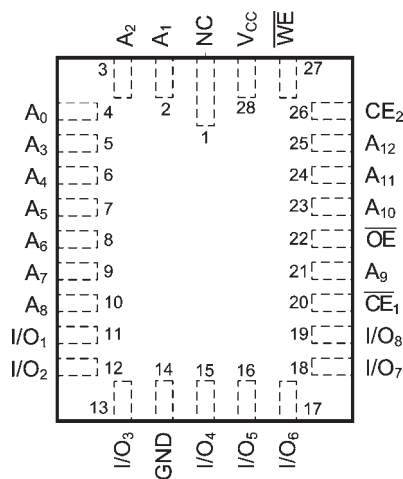

LCC (L5)
"LS" - SPECIAL PIN-OUT

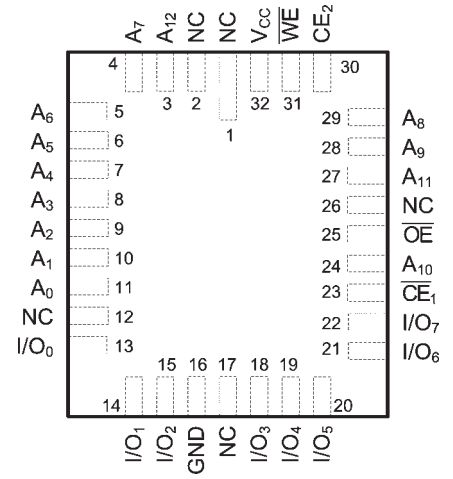

LCC (L6)

ORDERING INFORMATION

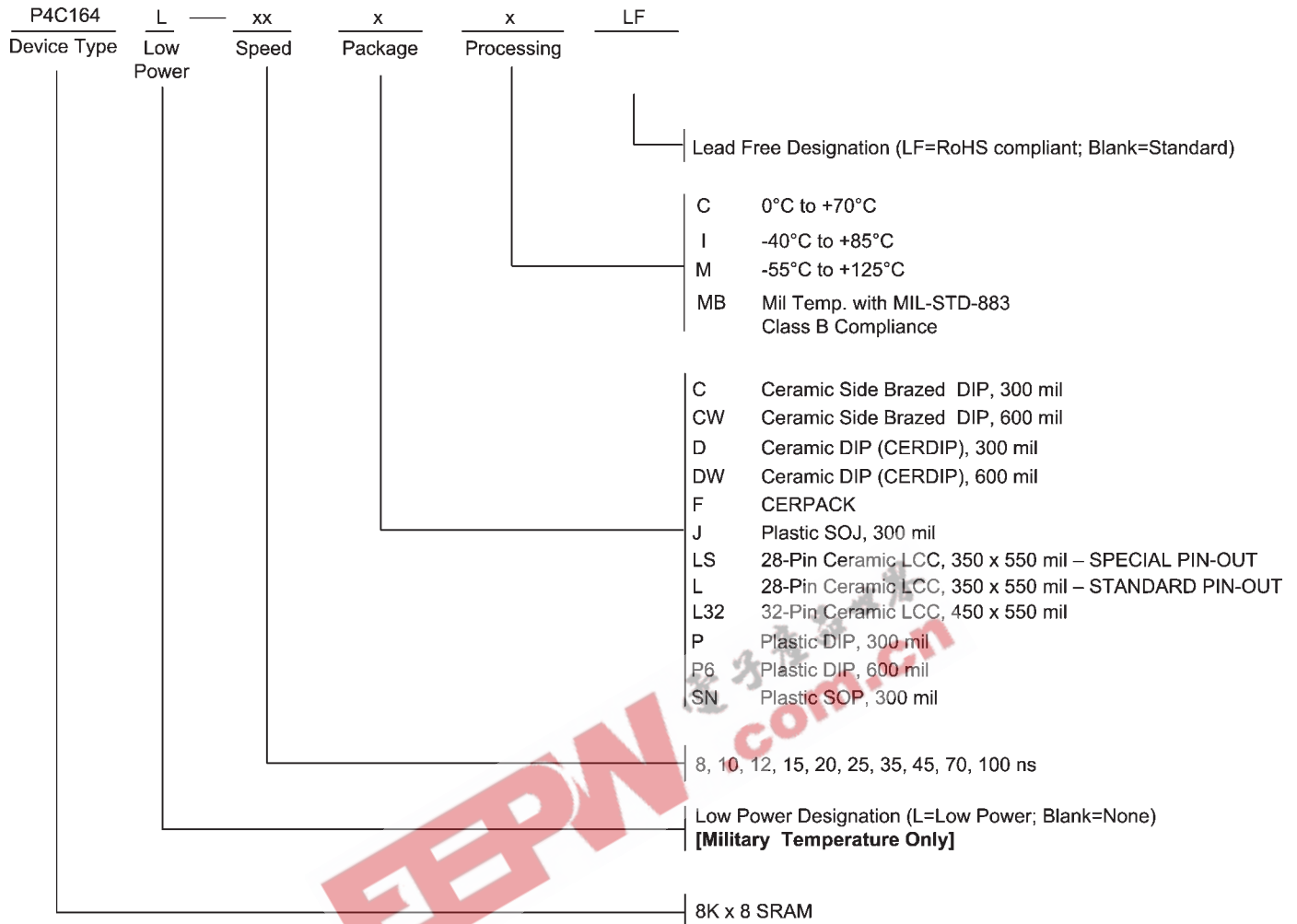

SELECTION GUIDE

The P4C164 is available in the following temperature, speed and package options. The P4C164L is available only over the military temperature range.

Temperature Range	Package	Speed (ns)									
		8	10	12	15	20	25	35	45	70	100
Commercial	Plastic DIP (300 mil)	-8PC	-10PC	-12PC	-15PC	-20PC	-25PC	-35PC	N/A	N/A	N/A
	Plastic DIP (600 mil)	N/A	N/A	N/A	N/A	N/A	N/A	N/A	N/A	-70P6C	-100P6C
	Plastic SOJ	-8JC	-10JC	-12JC	-15JC	-20JC	-25JC	-35JC	N/A	N/A	N/A
	Plastic SOP	N/A	N/A	N/A	N/A	N/A	N/A	N/A	N/A	-70SNC	-100SNC
Industrial	Plastic DIP (300 mil)	N/A	-10PI	-12PI	-15PI	-20PI	-25PI	-35PI	N/A	N/A	N/A
	Plastic DIP (600 mil)	N/A	N/A	N/A	N/A	N/A	N/A	N/A	N/A	-70P6I	-100P6I
	Plastic SOJ	N/A	-10JI	-12JI	-15JI	-20JI	-25JI	-35JI	N/A	N/A	N/A
	Plastic SOP	N/A	N/A	N/A	N/A	N/A	N/A	N/A	N/A	-70SNI	-100SNI

N/A = Not available

SELECTION GUIDE (continued)

Temperature Range	Package	Speed (ns)									
		8	10	12	15	20	25	35	45	70	100
Military Temperature	Side Brazed DIP	N/A	N/A	-12CM	-15CM	-20CM	-25CM	-35CM	-45CM	-70CM	-100CM
	CERDIP (300 mil)	N/A	N/A	-12DM	-15DM	-20DM	-25DM	-35DM	-45DM	-70DM	-100DM
	CERDIP (600 mil)	N/A	N/A	-12DWM	-15DWM	-20DWM	-25DWM	-35DWM	-45DWM	-70DWM	-100DWM
	CERPACK	N/A	N/A	-12FM	-15FM	-20FM	-25FM	-35FM	-45FM	-70FM	-100FM
	28-Pin LCC	N/A	N/A	-12LM	-15LM	-20LM	-25LM	-35LM	-45LM	-70LM	-100LM
	28-Pin LCC **	N/A	N/A	-12LSM	-15LSM	-20LSM	-25LSM	-35LSM	-45LSM	-70LSM	-100LSM
	32-Pin LCC	N/A	N/A	-12L32M	-15L32M	-20L32M	-25L32M	-35L32M	-45L32M	-70L32M	-100L32M
Military Processed *	Side Brazed DIP	N/A	N/A	-12CMB	-15CMB	-20CMB	-25CMB	-35CMB	-45CMB	-70CMB	-100CMB
	CERDIP (300 mil)	N/A	N/A	-12DMB	-15DMB	-20DMB	-25DMB	-35DMB	-45DMB	-70DMB	-100DMB
	CERDIP (600 mil)	N/A	N/A	-12DWMB	-15DWMB	-20DWMB	-25DWMB	-35DWMB	-45DWMB	-70DWMB	-100DWMB
	CERPACK	N/A	N/A	-12FMB	-15FMB	-20FMB	-25FMB	-35FMB	-45FMB	-70FMB	-100FMB
	28-Pin LCC	N/A	N/A	-12LMB	-15LMB	-20LMB	-25LMB	-35LMB	-45LMB	-70LMB	-100LMB
	28-Pin LCC **	N/A	N/A	-12LSMB	-15LSMB	-20LSMB	-25LSMB	-35LSMB	-45LSMB	-70LSMB	-100LSMB
	32-Pin LCC	N/A	N/A	-12L32MB	-15L32MB	-20L32MB	-25L32MB	-35L32MB	-45L32MB	-70L32MB	-100L32MB

* Military temperature range with MIL-STD-883, Class B processing.

**SPECIAL PINOUT

N/A = Not available

EEPW.com.cn 电子产品世界

Pkg #	C5	
# Pins	28 (300 mil)	
Symbol	Min	Max
A	-	0.225
b	0.014	0.026
b2	0.045	0.065
C	0.008	0.018
D	-	1.485
E	0.240	0.310
eA	0.300 BSC	
e	0.100 BSC	
L	0.125	0.200
Q	0.015	0.070
S1	0.005	-
S2	0.005	-

SIDE BRAZED DUAL IN-LINE PACKAGE (300 mils)

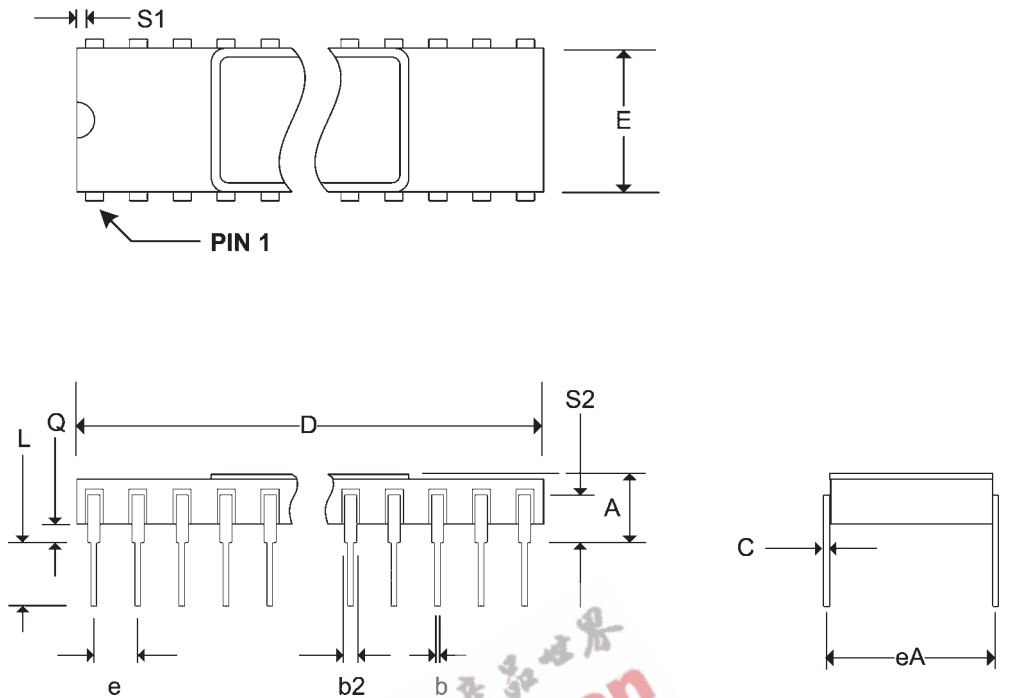

Pkg #	C5-1	
# Pins	28 (600 mil)	
Symbol	Min	Max
A	-	0.232
b	0.014	0.026
b2	0.045	0.065
C	0.008	0.018
D	-	1.490
E	0.500	0.610
eA	0.600 BSC	
e	0.100 BSC	
L	0.125	0.200
Q	0.015	0.060
S1	0.005	-
S2	0.005	-

SIDE BRAZED DUAL IN-LINE PACKAGE (600 mils)

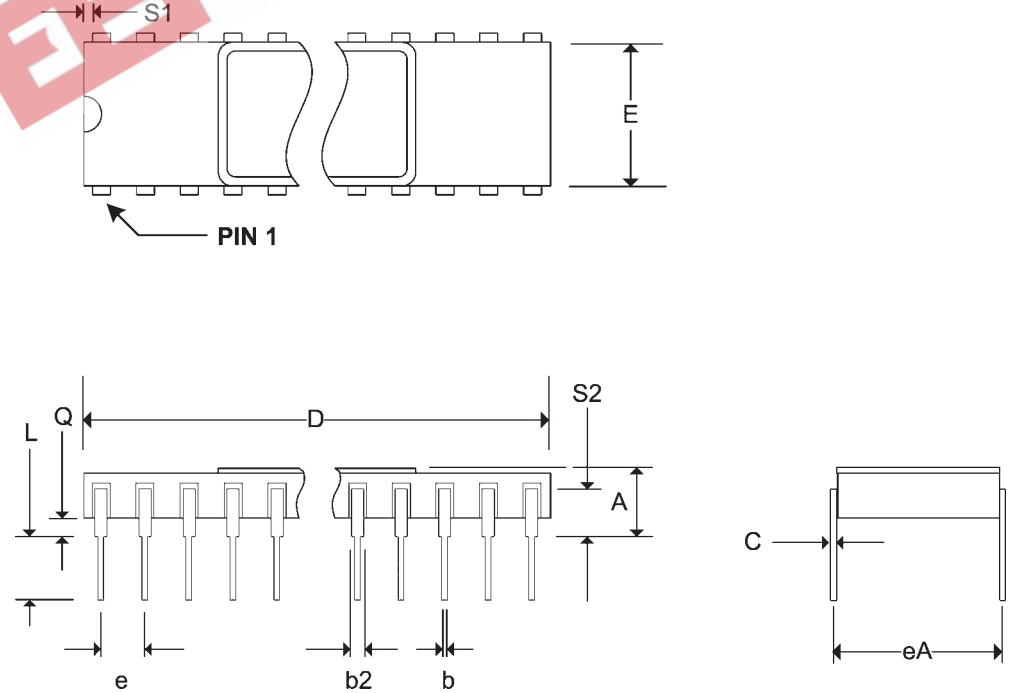

Pkg #	D5-1	
# Pins	28 (600 mil)	
Symbol	Min	Max
A	-	0.232
b	0.014	0.026
b2	0.045	0.065
C	0.008	0.018
D	-	1.490
E	0.500	0.610
eA	0.600 BSC	
e	0.100 BSC	
L	0.125	0.200
Q	0.015	0.060
S1	0.005	-
α	0°	15°

CERDIP DUAL IN-LINE PACKAGE

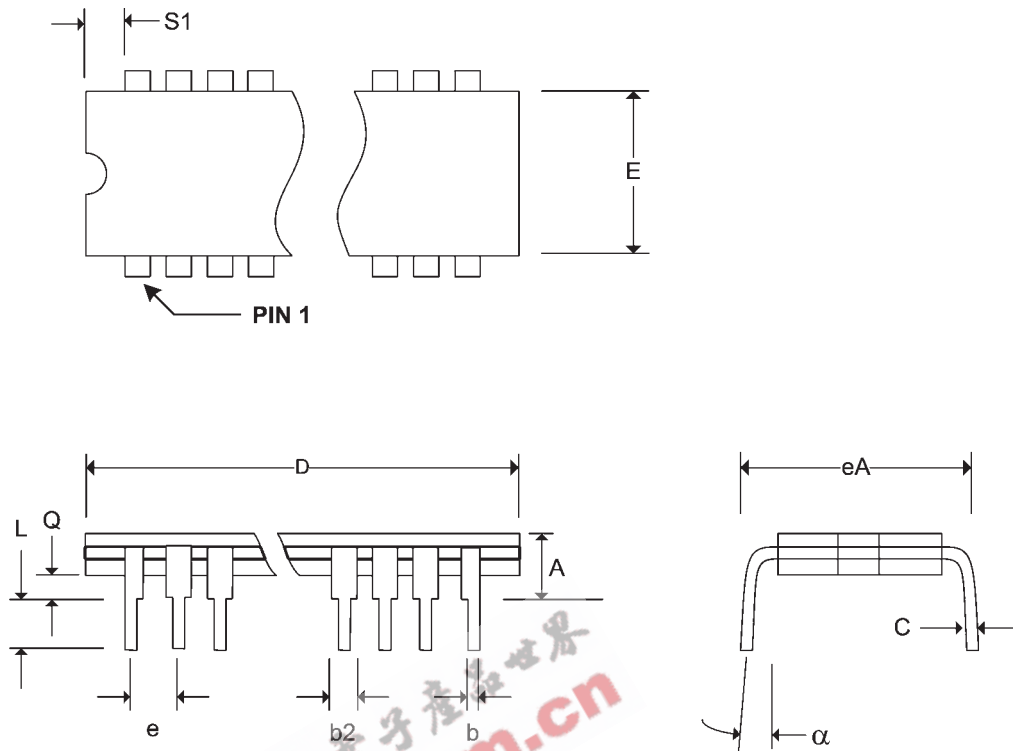

Pkg #	D5-2	
# Pins	28 (300 mil)	
Symbol	Min	Max
A	-	0.225
b	0.014	0.026
b2	0.045	0.065
C	0.008	0.018
D	-	1.485
E	0.240	0.310
eA	0.300 BSC	
e	0.100 BSC	
L	0.125	0.200
Q	0.015	0.060
S1	0.005	-
α	0°	15°

CERDIP DUAL IN-LINE PACKAGE

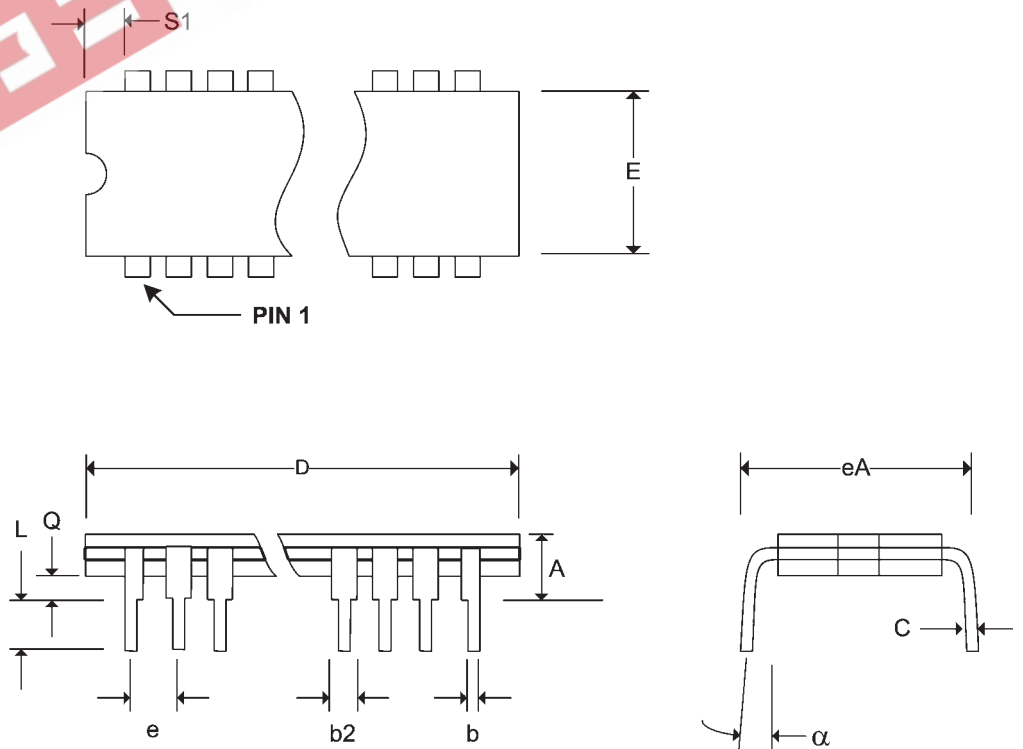

Pkg #	F4	
# Pins	28	
Symbol	Min	Max
A	0.060	0.090
b	0.015	0.022
c	0.004	0.009
D	-	0.730
E	0.330	0.380
e	0.050 BSC	
k	0.005	0.018
L	0.250	0.370
Q	0.026	0.045
S	-	0.085
S1	0.005	-

CERPACK CERAMIC FLAT PACKAGE

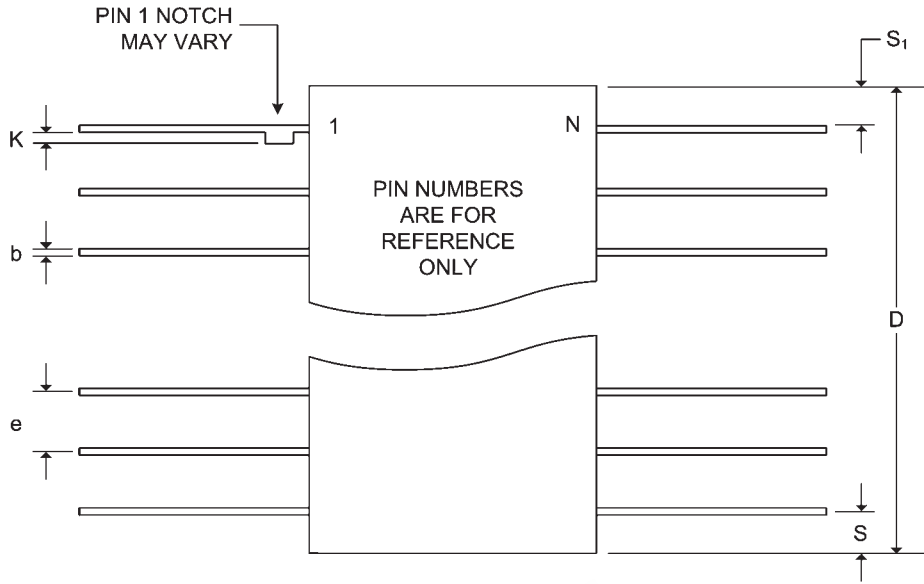

Pkg #	J5	
# Pins	28 (300 mil)	
Symbol	Min	Max
A	0.120	0.148
A1	0.078	-
b	0.014	0.020
C	0.007	0.011
D	0.700	0.730
e	0.050 BSC	
E	0.335 BSC	
E1	0.292	0.300
E2	0.267 BSC	
Q	0.025	-

SOJ SMALL OUTLINE IC PACKAGE

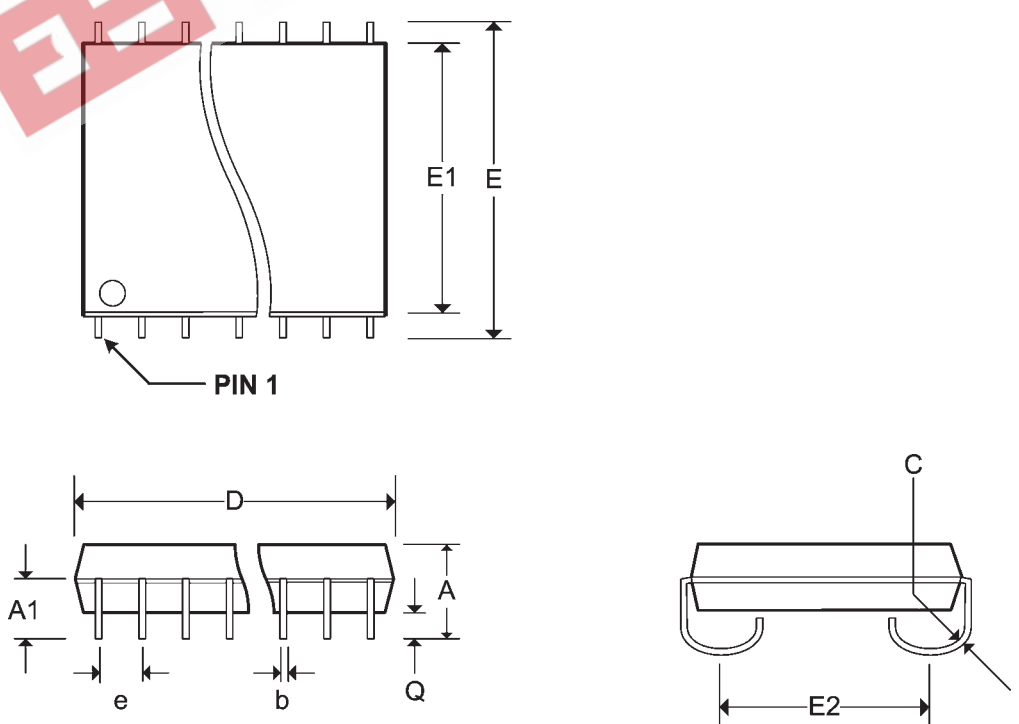

Pkg #	L5	
# Pins	28	
Symbol	Min	Max
A	0.060	0.075
A1	0.050	0.065
B1	0.022	0.028
D	0.342	0.358
D1	0.200 BSC	
D2	0.100 BSC	
D3	-	0.358
E	0.540	0.560
E1	0.400 BSC	
E2	0.200 BSC	
E3	-	0.558
e	0.050 BSC	
h	0.040 REF	
j	0.020 REF	
L	0.045	0.055
L1	0.045	0.055
L2	0.075	0.095
ND	5	
NE	9	

RECTANGULAR LEADLESS CHIP CARRIER

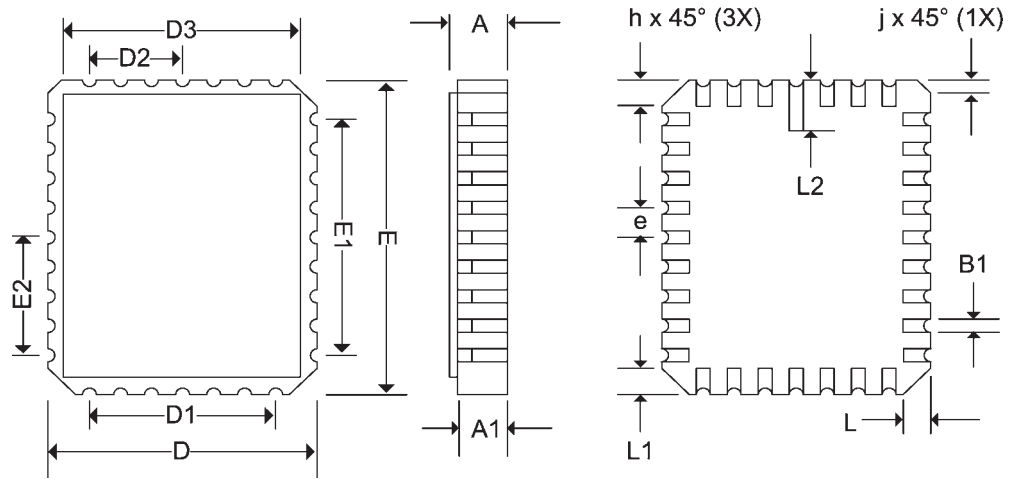

Pkg #	L6	
# Pins	32	
Symbol	Min	Max
A	0.060	0.075
A1	0.050	0.065
B1	0.022	0.028
D	0.442	0.458
D1	0.300 BSC	
D2	0.150 BSC	
D3	-	0.458
E	0.540	0.560
E1	0.400 BSC	
E2	0.200 BSC	
E3	-	0.558
e	0.050 BSC	
h	0.040 REF	
j	0.020 REF	
L	0.045	0.055
L1	0.045	0.055
L2	0.075	0.095
ND	7	
NE	9	

RECTANGULAR LEADLESS CHIP CARRIER

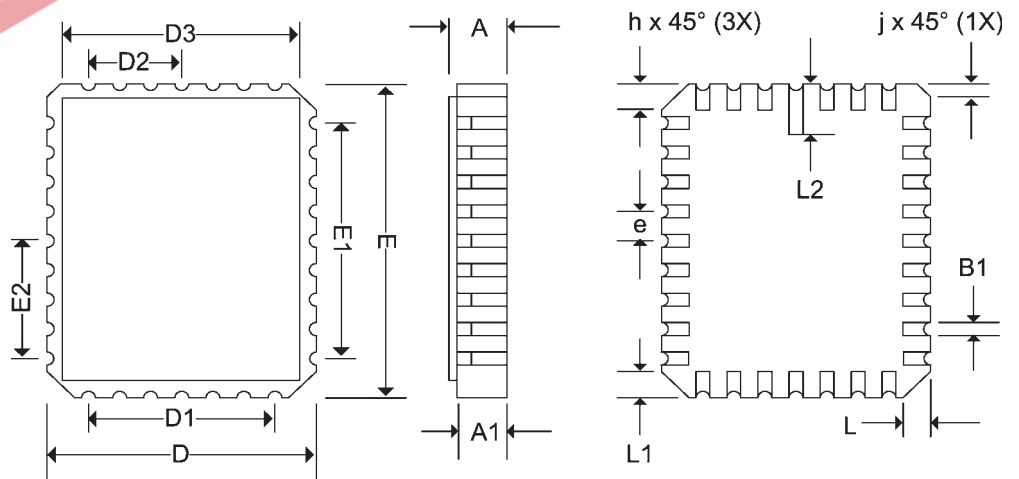

Pkg #	P5	
# Pins	28 (300 mil)	
Symbol	Min	Max
A	-	0.210
A1	-	-
b	0.014	0.023
b2	0.045	0.070
C	0.008	0.014
D	1.345	1.400
E1	0.270	0.300
E	0.300	0.380
e	0.100 BSC	
eB	-	0.430
L	0.115	0.150
α	0°	15°

PLASTIC DUAL IN-LINE PACKAGE (300 mils)

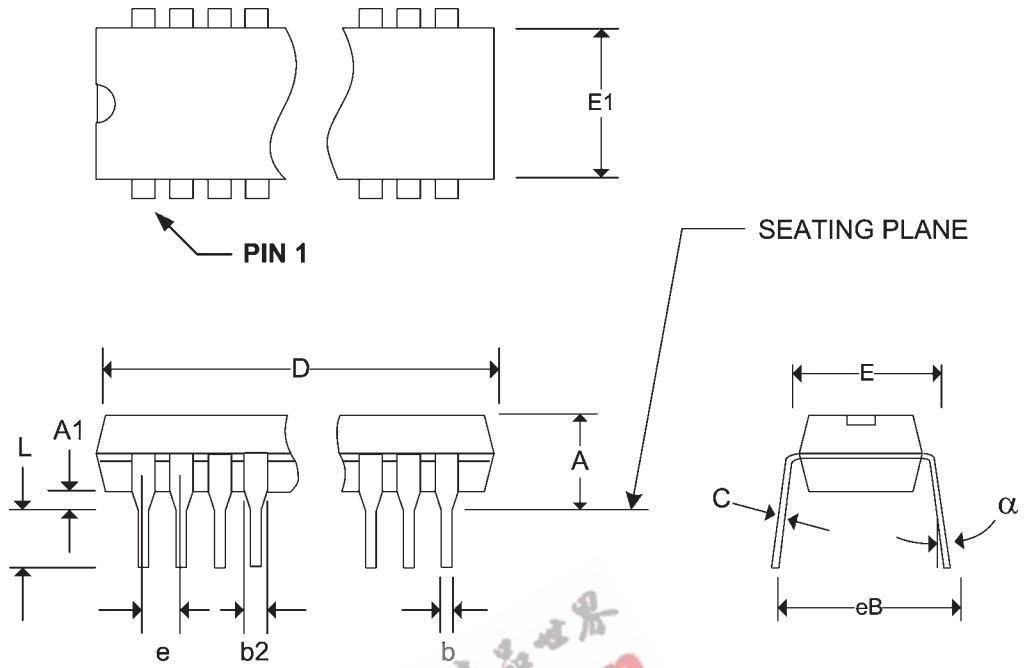

Pkg #	P6	
# Pins	28 (600 mil)	
Symbol	Min	Max
A	0.090	0.200
A1	0.000	0.070
b	0.014	0.020
b2	0.015	0.065
C	0.008	0.012
D	1.380	1.480
E1	0.485	0.550
E	0.600	0.625
e	0.100 BSC	
eB	0.600 TYP	
L	0.100	0.200
α	0°	15°

PLASTIC DUAL IN-LINE PACKAGE (600 mils)

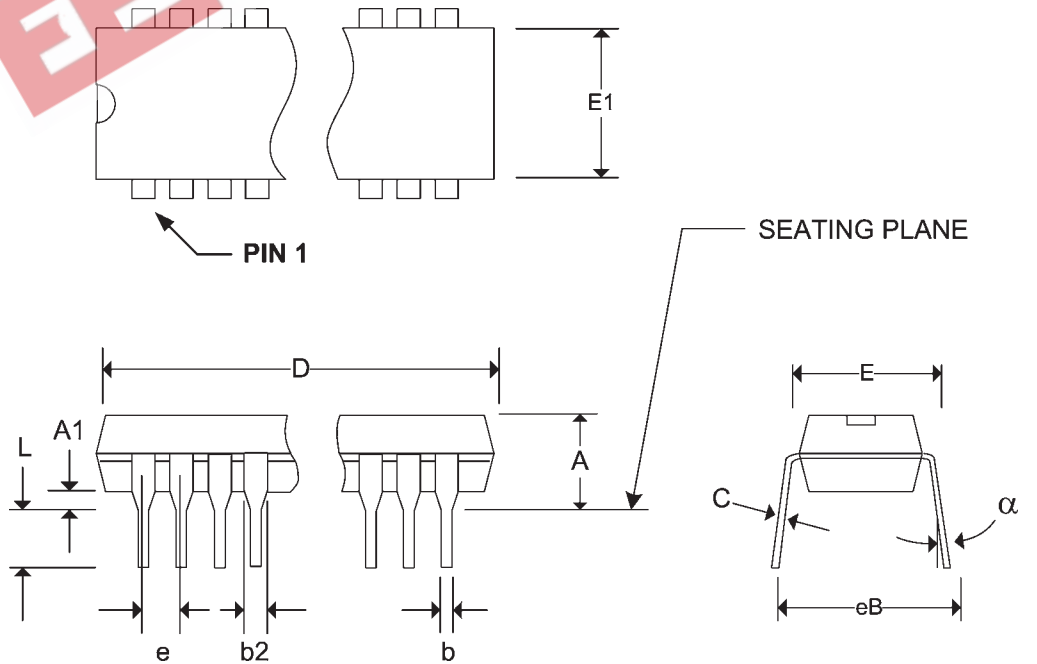

Pkg #	S6	
# Pins	28 (300 mil)	
Symbol	Min	Max
A	0.090	0.110
A1	0.003	0.010
B	0.012	0.020
C	0.004	0.012
D	0.700	0.716
e	0.050 BSC	
E	0.290	0.300
H	0.465	0.485
L	0.016	0.050
α	0°	9°

SOIC/SOP SMALL OUTLINE IC PACKAGE (SN)

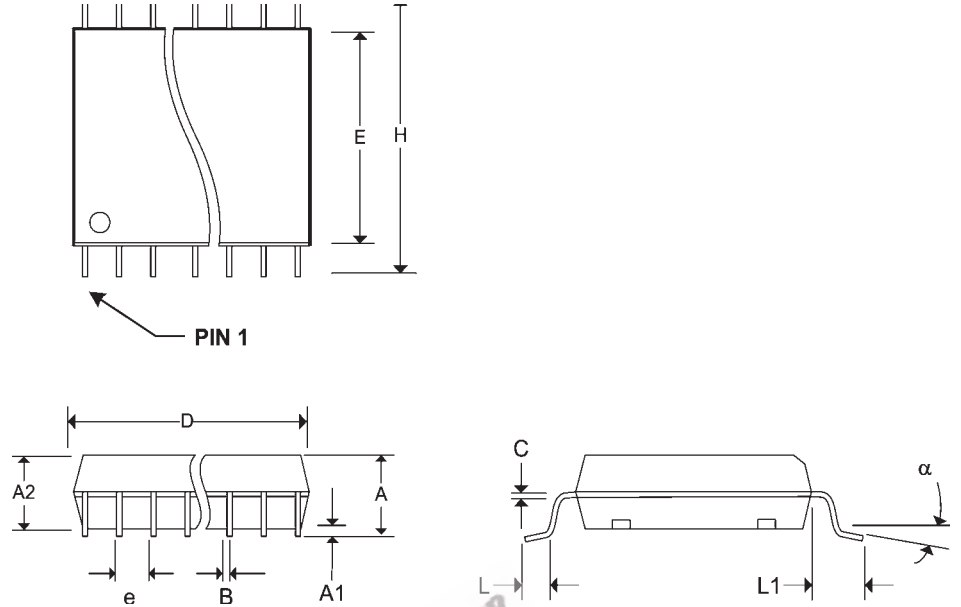

EEPW.com.cn 电子产品世界

REVISIONS

DOCUMENT NUMBER:		SRAM115	
DOCUMENT TITLE:		P4C164 ULTRA HIGH SPEED 8K x 8 STATIC CMOS RAMS	
REV.	ISSUE DATE	ORIG. OF CHANGE	DESCRIPTION OF CHANGE
OR	1997	DAB	New Data Sheet
A	Oct-05	JDB	Change logo to Pyramid
B	Jun-06	JDB	Added 28-pin ceramic DIP
C	Aug-06	JDB	Added Lead Free Designation
D	Aug-06	JDB	Added "LS" - SPECIAL PIN-OUT
E	Aug-06	JDB	Updated SOJ package information
F	Jun-07	JDB	Corrected SOP package details