

8-Port 10 Mbit/s Switch

FEATURES

- Single-chip, 8-port, 10BaseT Ethernet switch device for low-cost unmanaged and managed networks.
- On-chip SmartPath™ 50 MHz RISC CPU core, multi-channel DMA controller, MAC-layer interface logic, FIFOs, PCI-based expansion port, and a flexible memory controller.
- CPU supports background applications running on local OS (e.g., SNMP), and real-time data-oriented applications (e.g., packet forwarding and filtering decisions).
- Concurrently switches packets between eight independent, half-duplex ports at the full Ethernet rate of 10 Mbit/s.
- Fully compatible with the PM3351, 1-port 10/100 Mbit/s switch device; may be used to create a compact and inexpensive mixed 10/100 Mbit/s switching hub.
- Store-and-forward operation with full error checking and filtering.
- Low-latency operation in both unicast and broadcast modes.
- Filtering and switching at wire rates (up to 148,800 packets per second), supporting a mix of Ethernet and IEEE 802.3 protocols.
- Performs all address learning, address table management, and aging functions for up to 32,768 MAC addresses (limited by external memory) with an address learning rate of up to 10,000 addresses per second.
- Maximum broadcast/multicast rate of 14,880 packets per second per port with configurable broadcast storm rate limiting.
- Backpressure flow control with configurable per-port buffer thresholds and limits.
- Expandable to 64 ports without loss in throughput using multiple PM3350 devices via an on-chip 1 Gbit/s expansion port.
- Expansion port supports a peak system bandwidth of 1 Gbit/s, and is compatible with industry-standard PCI bus (version 2.1).
- Interfaces directly to industry-standard 10BaseT Ethernet Medium Access Unit devices (LXT944 or similar) with no glue logic.
- Configuration, management, MIB statistics, and diagnostics available in-band (via on-chip SNMP agent with integral TCP/UDP/IP stack).
- Maintains and collects per-port and per-host statistics at wire rates.
- Fully static CMOS operation at 50 MHz clock rates.
- Implemented with a 3.3 V core and a 5 V-compatible I/O.
- Available in a 256-pin Ball Grid Array (BGA) package.

BLOCK DIAGRAM

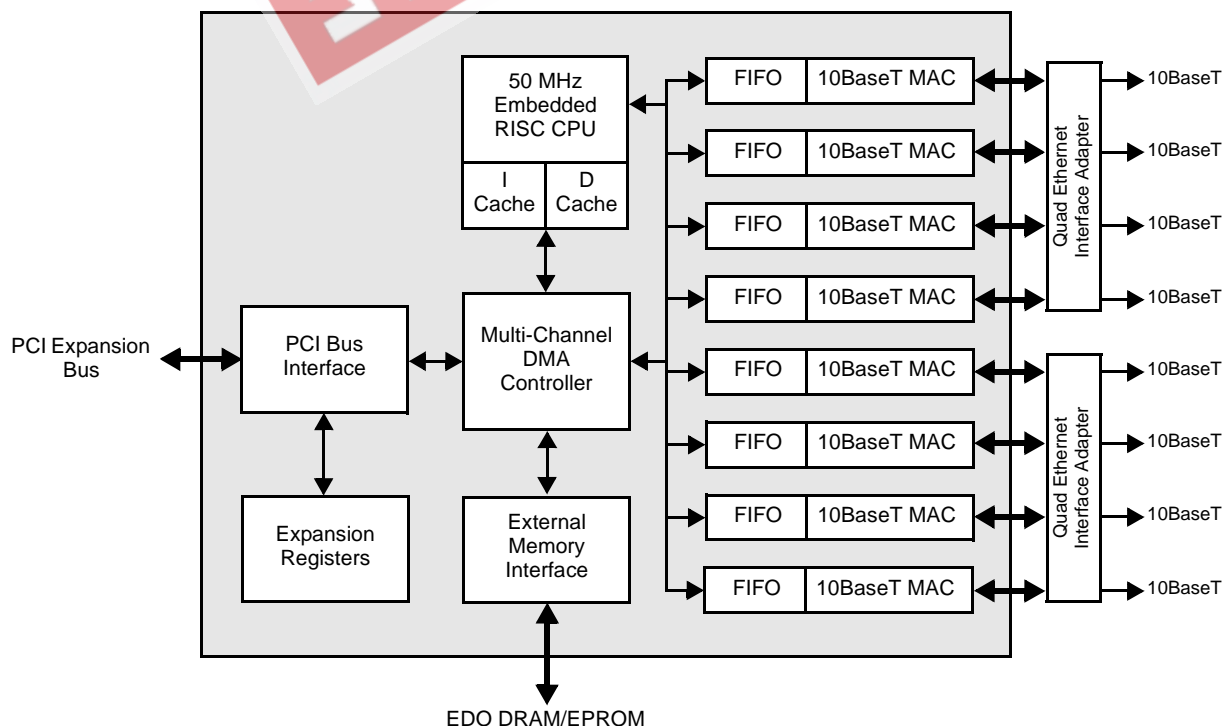

8-Port 10 Mbit/s Switch

TYPICAL APPLICATIONS

LOW-COST 10 Mbit/s SWITCHES

The ELAN 8x10 chip can act as a stand-alone managed or unmanaged switching device in low-cost, compact switch applications. Eight to sixty-four ports of 10BaseT switches can be built using the internal PCI expansion port. A typical system would use the following:

- PM3350 (one for every eight ports),
- two 256k × 16-bit 60 ns EDO or Fast Page Mode DRAM chips per ELAN 8x10 chip,
- an EPROM or EEPROM (initialization, configuration, SNMP support firmware),
- quad Ethernet interface adapters (LXT944), and
- appropriate passive components.

A block diagram of a typical 8-port 10BaseT stackable switch is shown.

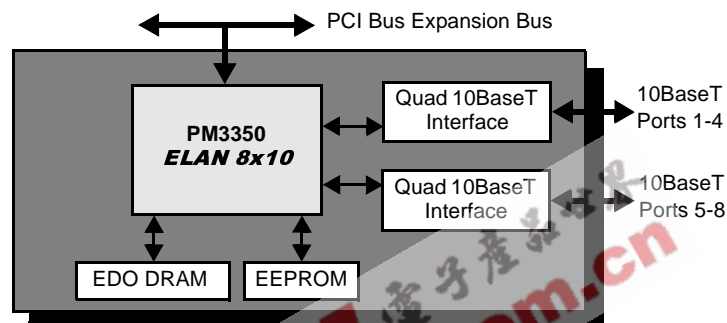

LOW-COST 10/100 Mbit/s SWITCHES

The ELAN 8x10 chip can be part of a fully managed 10/100 switch using the PM3351 ELAN 1x100 10/100 Mbit/s switch chip. Together they can form a workgroup or desktop application. A block diagram of a typical 32-port 10BaseT stackable switch with two 10/100 Mbit/s ports is shown. The PCI expansion bus is used to seamlessly connect the ELAN 8x10s and ELAN 1x100s.

