

SRAM

32K X 8 LOW POWER CMOS STATIC RAM

FEATURES

- Access time: 35ns/70ns
- Low power consumption : Active 200 mW(typ.)
- Low operating current : 50mA
- Single + 3.3V power supply
- Fully static operation – No clock or refreshing required
- All inputs and outputs directly LVTTTL compatible
- Common I/O capability
- Available packages : 28-pin 300 mil SOJ, 28-pin SOP, TSOP-I (forward type).
- Output enable (\overline{OE}) available for very fast access

GENERAL DESCRIPTION

The T15L256A is a high speed, low power CMOS static RAM organized as 32,768 x 8 bits that operates on a single 3.3-volt power supply. This device is packaged in standard 28-pin 300 mil SOJ , 28-pin SOP, TSOP-I forward.

BLOCK DIAGRAM

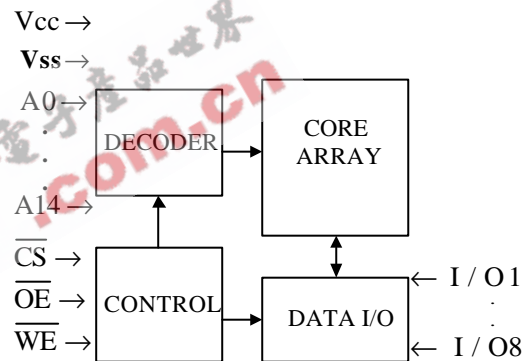

PIN CONFIGURATION

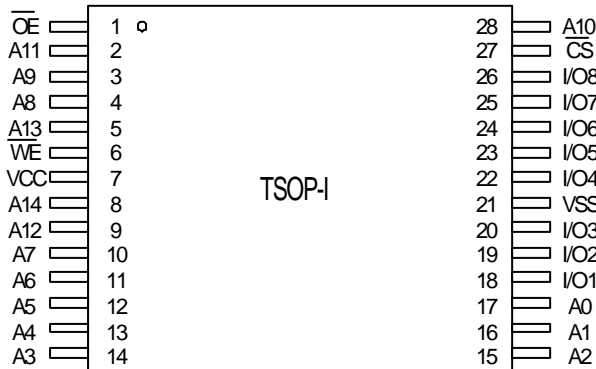
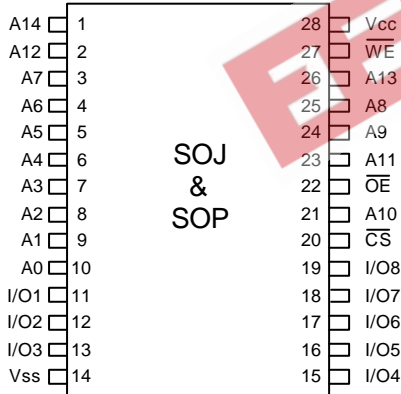

PIN DESCRIPTION

SYMBOL	DESCRIPTION
A0 - A14	Address Inputs
I/O1 - I/O8	Data Inputs/Outputs
\overline{CS}	Chip Select Inputs
\overline{WE}	Write Enable
\overline{OE}	Output Enable
Vcc	Power Supply
Vss	Ground

PART NUMBER EXAMPLES

	PACKAGE	SPEED
T15L256A-35J	SOJ	35ns
T15L256A-70P	TSOP-I	70ns
T15L256A-70D	SOP	70ns

DC CHARACTERISTICS ABSOLUTE MAXIMUM RATINGS

PARAMETER	RATING	UNIT
Supply Voltage to Vss Potential	-0.5 to + 4.6	V
Inputs to Vss Potential	-0.5 to Vcc +0.5	V
Power Dissipation	0.5	W
Storage Temperature	-60 to +150	°C

RECOMMENDED OPERATING CONDITIONS

PARAMETER	SYM	MIN	TYP	MAX	UNIT
Supply Voltage	Vcc	Typ-5%	3.3	Typ+5%	V
Input Voltage, low	V _{IL}	-0.3	-	0.8	V
Input Voltage, high	V _{IH}	2.1	-	Vcc+0.3	V
Ambient Temperature	T _A	0	-	70	°C

TRUTH TABLE

CS	OE	WE	MODE	I/O1- I/O8	Vcc
H	X	X	Not Selected	High-Z	I _{SB} , I _{SBI}
L	H	H	Output Disable	High-Z	I _{cc}
L	L	H	Read	Data Out	I _{cc}
L	X	L	Write	Data In	I _{cc}

OPERATING CHARACTERISTICS

(Vcc = 3.3V± 5%, Vss = 0V, Ta = 0 to 70°C)

PARAMETER	SYM	TEST CONDITIONS	MIN.	TYP.	MAX.	UNIT	
Input Leakage Current	I _{LI}	Vin=Vss to Vcc	-10	-	+10	uA	
Output Leakage Current	I _{LO}	V _{I/O} =Vss to Vcc, CS = V _{IH} or OE= V _{IH} or WE = V _{IL}	-10	-	+10	uA	
Output Low Voltage	V _{OL}	I _{OL} = + 8.0mA	-	-	0.4	V	
Output High Voltage	V _{OH}	I _{OH} = - 4.0mA	2.4	-	-	V	
Operating Power Supply Current	I _{cc}	CS = V _{IL} , I/O=0mA Cycle = MIN. Duty = 100%	-35	-	-	40	mA
			-70	-	-	35	mA
Standby Power Supply Current	I _{SB}	CS = V _{IH} , Cycle=MIN, Duty=100%	-	-	8	mA	
	I _{SBI}	CS ≥ V _{cc} -0.2V, f=0MHZ	-	-	0.8	mA	

Note: Typical characteristics are at Vcc = 3.3V, Ta = 25°C

CAPACITANCE

(V_{CC} = 3.3V, Ta = 25°C, f = 1 MHz)

PARAMETER	SYMBOL	CONDITION	MAX.	UNIT
Input Capacitance	C _{IN}	V _{IN} = 0V	6	pF
Input/ Output Capacitance	C _{I/O}	V _{OUT} = 0V	8	pF

Note: These parameters are sampled but not 100% tested.

AC TEST CONDITIONS

PARAMETER	CONDITIONS
Input Pulse Levels	0V to 3V
Input Rise and Fall Times	3 ns
Input and Output Timing Reference Level	1.5V
Output Load	C _L = 30pF, I _{OH} /I _{OL} = -4mA/8mA

AC TEST LOADS AND WAVEFORM

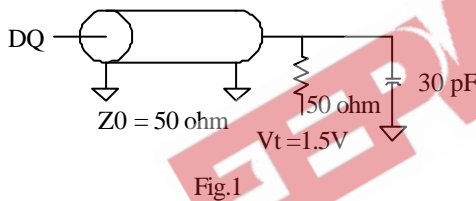

Fig.1

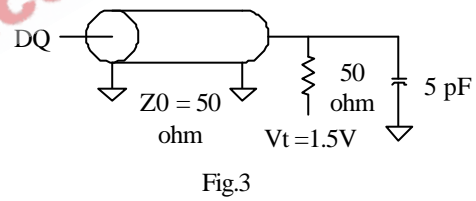

Fig.3

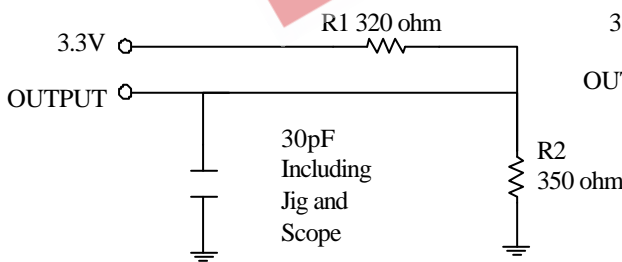

Fig.2

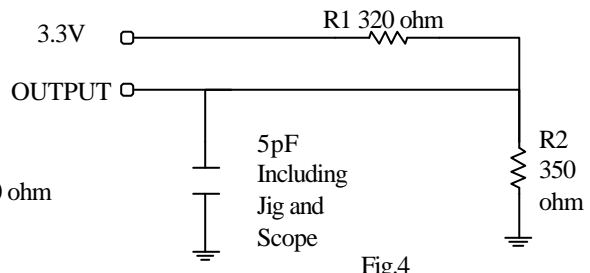

Fig.4

(For TCLZ, TOLZ, TCHZ, TOHZ, TWHZ, TOW)

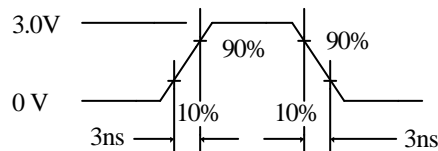

Fig.5

AC CHARACTERISTICS

(V_{CC} = 3.3V ± 5%, V_{SS} = 0V, Ta = 0 to 70°C)

(1) READ CYCLE

PARAMETER	SYM.	T15M256A-35		T15M256A-70		UNIT
		MIN.	MAX.	MIN.	MAX.	
Read Cycle Time	T _{RC}	35	-	70	-	ns
Address Access Time	T _{AA}	-	35	-	70	ns
Chip Select Access Time	T _{ACS}	-	35	-	70	ns
Output Enable to Output Valid	T _{AOE}	-	25	-	35	ns
Chip Selection to Output in Low Z	T _{CLZ*}	3	-	3	-	ns
Output Enable to Output in Low Z	T _{OLZ}	0	-	0	-	ns
Chip Deselection to Output in High Z	T _{CHZ*}	-	25	-	35	ns
Output Disable to Output in High Z	T _{OHZ*}	-	25	-	35	ns
Output Hold from Address Change	T _{OH}	3	-	3	-	ns

* These parameters are sampled but not 100% tested.

(2) WRITE CYCLE

PARAMETER	SYM.	T15M256A-35		T15M256A-70		UNIT
		MIN.	MAX.	MIN.	MAX.	
Write Cycle Time	T _{WC}	35	-	70	-	ns
Chip Selection to End of Write	T _{CW}	30	-	60	-	ns
Address Valid to End of Write	T _{AW}	30	-	60	-	ns
Address Setup Time	T _{AS}	0	-	0	-	ns
Write Pulse Width	T _{WP}	25	-	50	-	ns
Write Recovery Time	T _{WR}	0	-	0	-	ns
Data Valid to End of Write	T _{DW}	20	-	30	-	ns
Data Hold from End of Write	T _{DH}	0	-	0	-	ns
Write to Output in High Z	T _{WHZ}	-	10	-	25	ns
Output Disable to Output in High Z	T _{OHZ}	-	10	-	25	ns
Output Active from End of Write	T _{OW}	0	-	0	-	ns

* These parameters are sampled but not 100% tested.

TIMING WAVEFORMS

READ CYCLE 1

(Address Controlled)

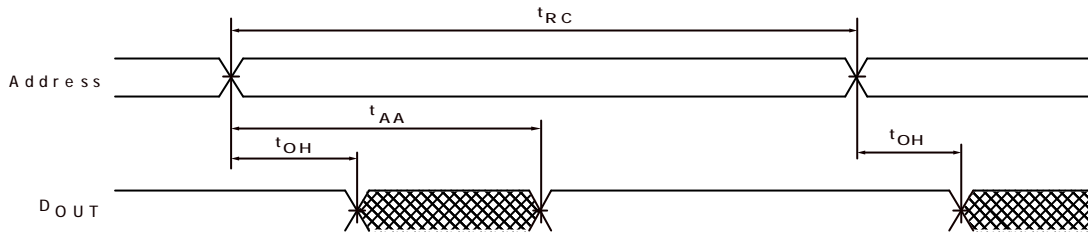

READ CYCLE 2

(Chip Select Controlled)

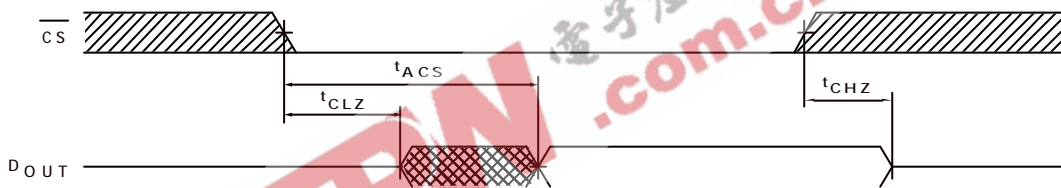

READ CYCLE 3

(Output Enable Controlled)

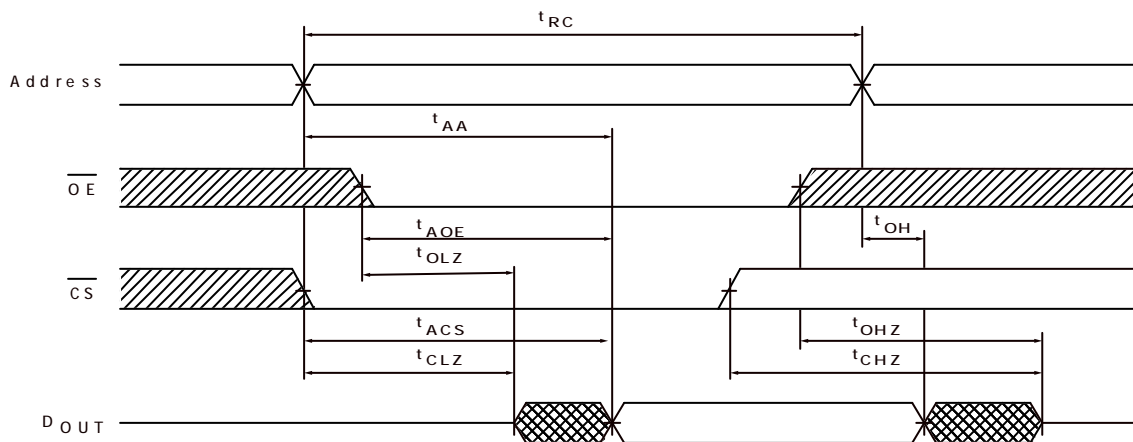

[Hatched Box] DON'T CARE
 [Cross-hatched Box] UNDEFINED

WRITE CYCLE 1 (\overline{OE} CLOCK)

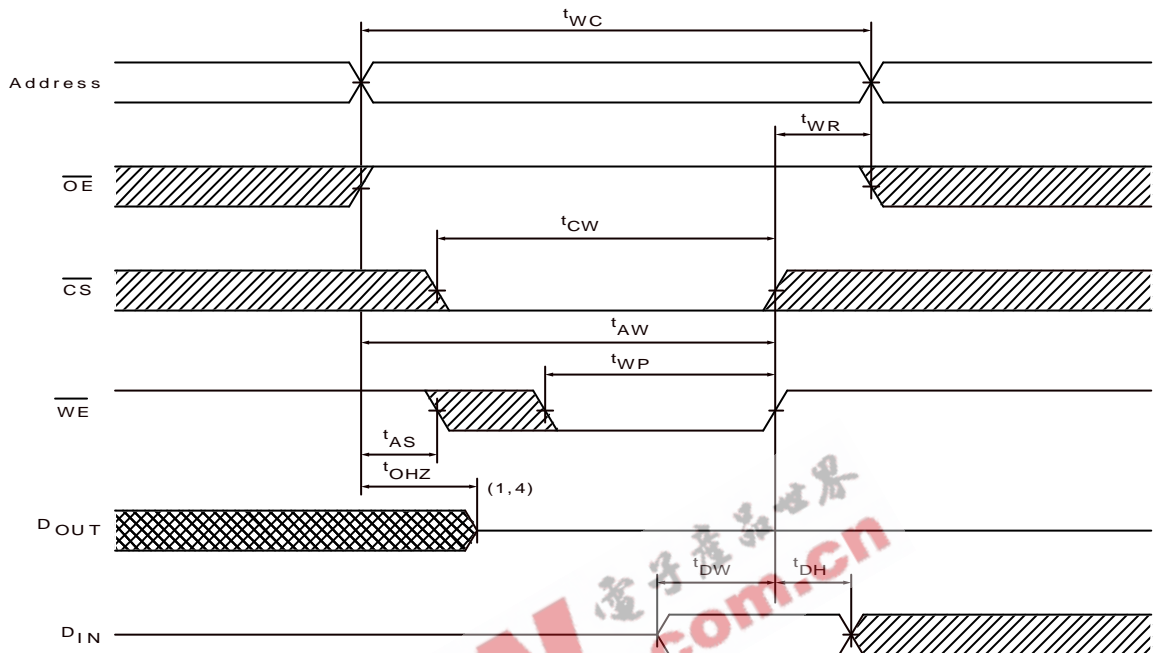

WRITE CYCLE 2 ($\overline{OE} = V_{IL}$ Fixed)

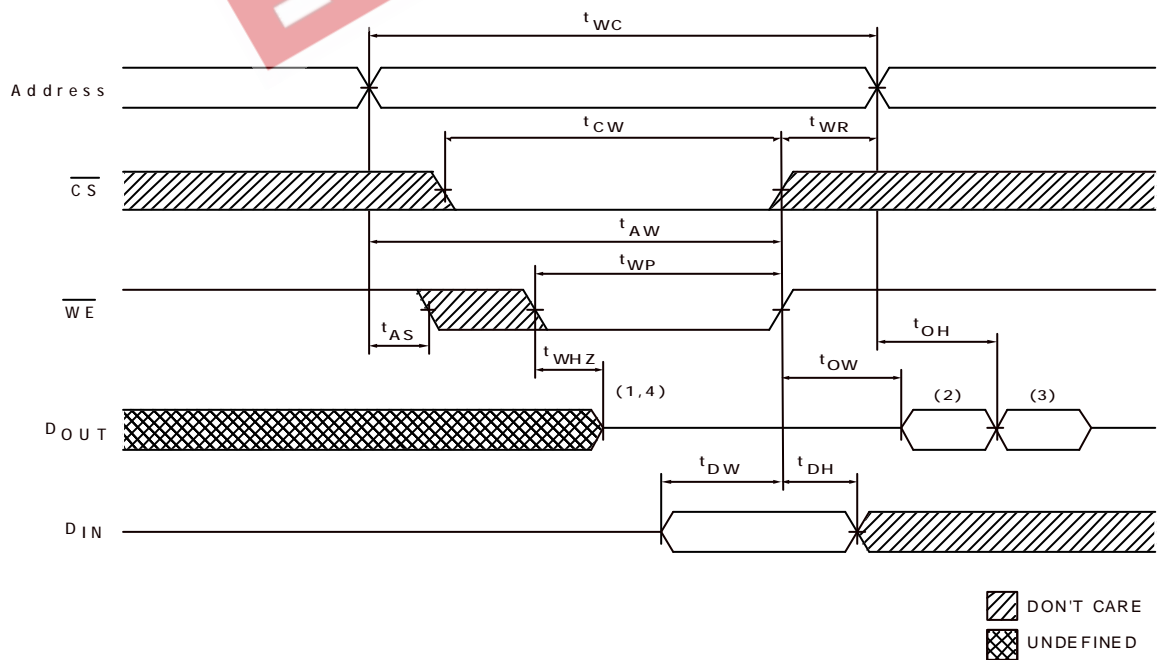

 DON'T CARE
 UNDEFINED

- Notes:
1. During this period, I/O pins are in the output state, so input signals of opposite phase to the outputs should not be applied.
 2. The data output from D_{OUT} are the same as the data written to D_{IN} during the write cycle.
 3. D_{OUT} provides the read data for the next address.
 4. Transition is measured ± 500 mV from steady state with $C_L = 5$ pF. This parameter is guaranteed but not 100% tested.
 5. If \overline{OE} is low during a \overline{WE} controlled write cycle, the write pulse width must be the larger of t_{WP} or $(t_{WHZ} + t_{DW})$ to allow the I/O drivers to turn off and data to be placed on the bus for the required t_{DW} . If \overline{OE} is high during a \overline{WE} controlled write cycle, this requirement does not apply and the write pulse can be as short as the specified t_{WP} .

EEPW 电子產品世界
.com.cn

PACKAGE DIMENSIONS
28-LEAD SOJ SRAM (300 mil)

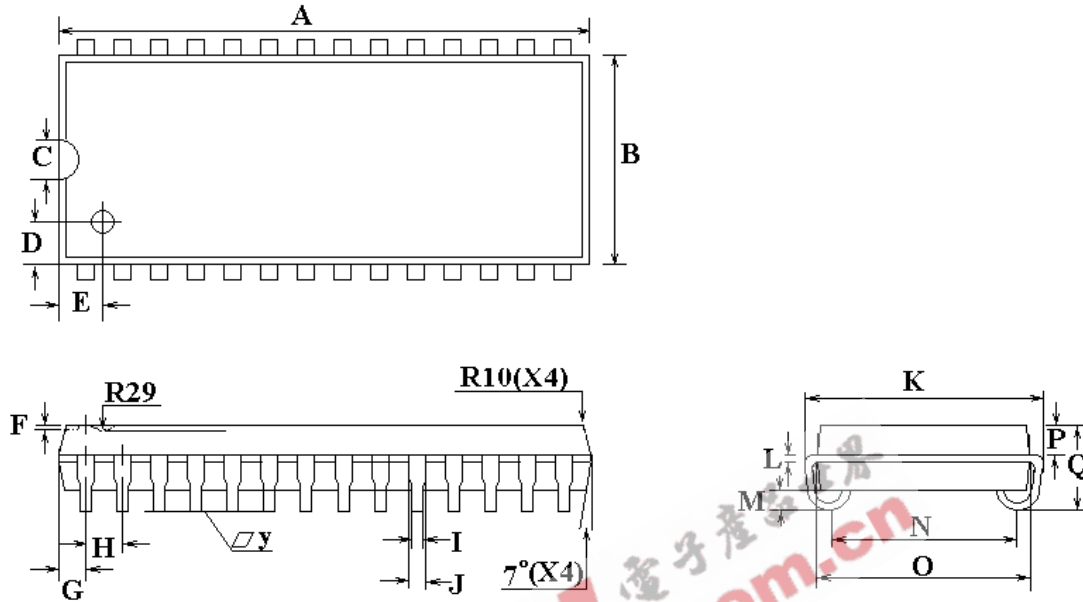

SYMBOL	DIMENSIONS IN INCHES	DIMENSIONS IN MM
A	0.710±0.002	18.03±0.05
B	0.300±0.005	7.62±0.13
C	0.060±0.002	1.52±0.05
D	0.050±0.001	1.27±0.03
E	0.063±0.001	1.63±0.03
F	0.015±0.002	0.38±0.05
G	0.030±0.002	0.76±0.05
H	0.050±0.002	1.27±0.05
I	0.018±0.002	0.46±0.05
J	0.028±0.002	0.71±0.05
K	0.337±0.002	8.56±0.05
L	0.010±0.001	0.25±0.03
M	0.026±0.002	0.66±0.05
N	0.268±0.003	6.81±0.08
O	0.300±0.002	7.62±0.05
P	0.053±0.001	1.35±0.03
Q	0.140±0.004	3.56±0.10
y	0.004(MAX)	0.10(MAX)

PACKAGE DIMENSIONS
28-LEAD TSOP-I SRAM (8X13.4mm)

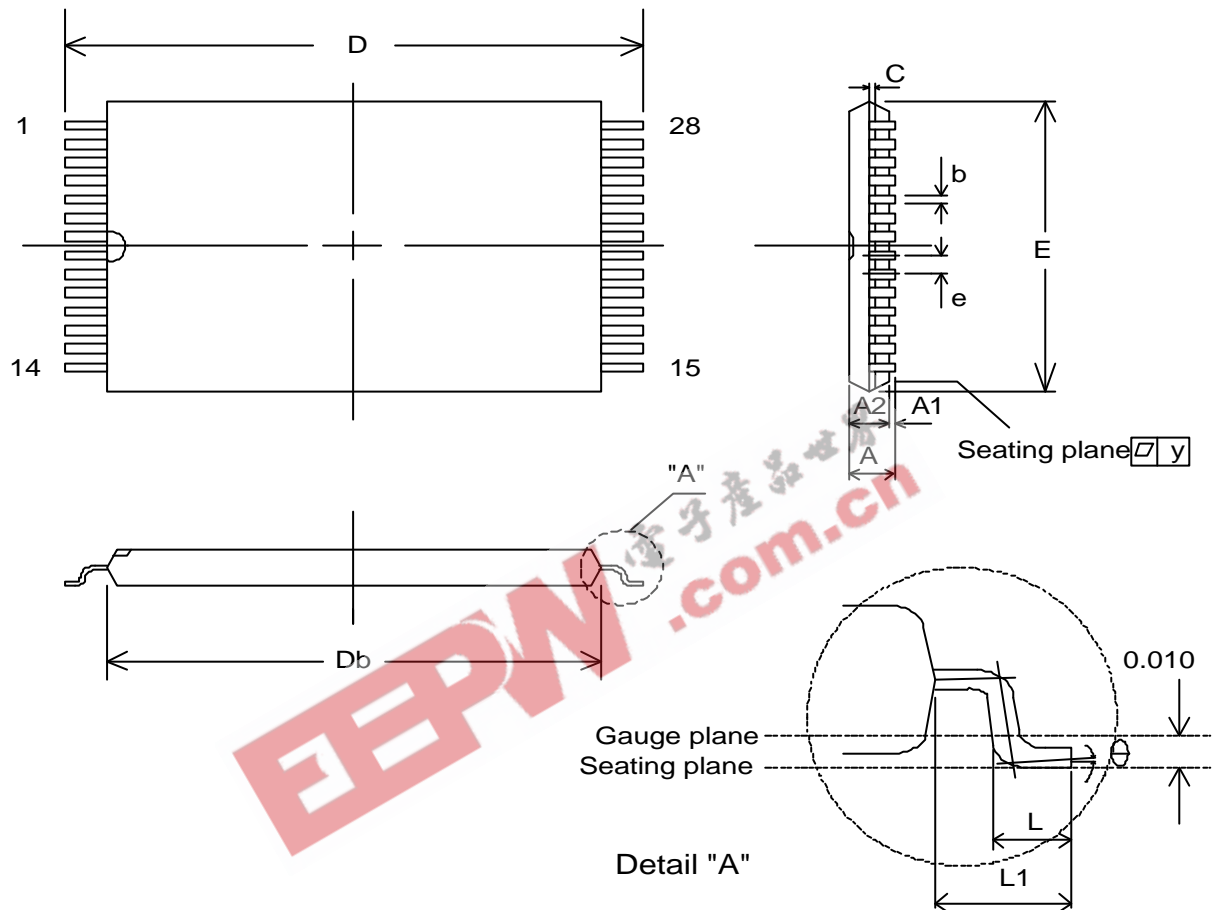

SYMBOL	DIMENSIONS IN INCHES	DIMENSIONS IN MM
A	0.047(max.)	1.20(max.)
A1	0.004±0.002	0.10±0.05
A2	0.039±0.002	1.00±0.05
b	0.008(typ.)	0.20(typ.)
c	0.006(typ.)	0.15(typ.)
Db	0.465±0.004	11.80±0.10
E	0.315±0.004	8.00±0.10
e	0.022(typ.)	0.55(typ.)
D	0.528±0.008	13.40±0.20
L	0.020±0.004	0.50±0.10
L1	0.0315±0.004	0.80±0.10
y	0.004(max.)	0.10(max.)
θ	0°~5°	0°~5°

PACKAGE DIMENSIONS
28-LEAD SOP

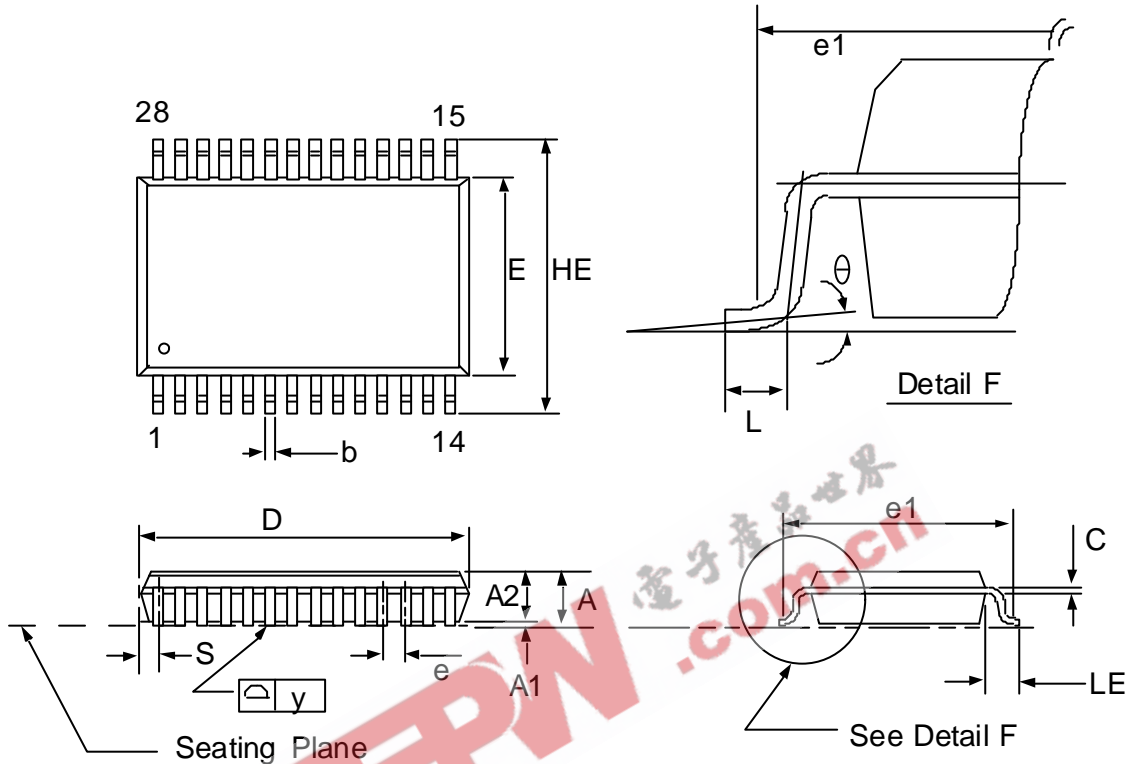

Symbol	Dimension in inches			Dimension in mm		
	min.	typ.	max	min.	typ.	max.
A	-	-	0.098	-	-	2.5
A1	0.01	-	-	0.25	-	-
A2	0.083	0.085	0.087	2.13	2.15	2.17
b	0.014	0.016	0.018	0.39	0.4	0.41
C	0.004	0.006	0.008	0.1	0.15	0.2
D	724	0.728	0.732	18.4	18.5	18.6
E	0.342	0.346	0.350	8.7	8.8	8.9
e	0.044	0.050	0.056	1.12	1.27	1.42
HE	0.453	0.465	0.476	11.5	11.8	12.1
L	0.026	0.033	0.041	0.65	0.85	1.05
LE	0.047	0.059	0.071	1.2	1.5	1.8
S	-	39	-	-	1.0	-
y	-	-	0.005	-	-	0.12
q	0°	-	10°	0°	-	10°

Notes :

1. Dimensions D max. & S include mold flash or tie bar burrs.
2. Dimension b does not include dambar protrusion / intrusion.
3. Dimensions D & E include mold mismatch and determined at the mold parting line.
4. controlling dimension : inches
5. general appearance spec should be based on final visual inspection spec.