



# STK17T88

## nvTime™ Event Data Recorder

### 32K x 8 AutoStore™ nvSRAM

### With Real-Time Clock

#### FEATURES

- Data Integrity of Simtek nvSRAM Combined with Full-Featured Real-Time Clock
  - Low Power, 300 nA Max, RTC current
  - Capacitor or battery backup for RTC
- Watchdog Timer
- Clock Alarm with programmable Interrupts
- 25ns, 35ns and 45ns Access Times
- “Hands-off” Automatic STORE on Power Down with only a small capacitor
- STORE to QuantumTrap™ Initiated by Software, device pin, or on Power Down
- RECALL to SRAM Initiated by Software or Power Up
- Unlimited READ, WRITE and RECALL Cycles
- High-reliability
  - Endurance to 1 Million Cycles
  - Retention to 100 years at 125 °C
- 5mA Typical I<sub>CC</sub> at 200ns Cycle Time
- Single 3V +20%, -10% Operation
- SSOP and DIP Packages, (ROHS compliant)

#### DESCRIPTION

The Simtek STK17T88 combines a 256 Kbit nonvolatile static RAM with a full-featured real-time clock in a reliable, monolithic integrated circuit. The embedded nonvolatile elements incorporate Simtek's QuantumTrap™ technology producing the world's most reliable nonvolatile memory. The SRAM can be read and written an unlimited number of times, while independent, nonvolatile data resides in the nonvolatile elements.

The Real-Time Clock function provides an accurate clock with leap year tracking and a programmable, high accuracy oscillator. The Alarm function is programmable for one-time alarms or periodic seconds, minutes, hours, or days. There is also a programmable Watchdog Timer for process control.

#### BLOCK DIAGRAM

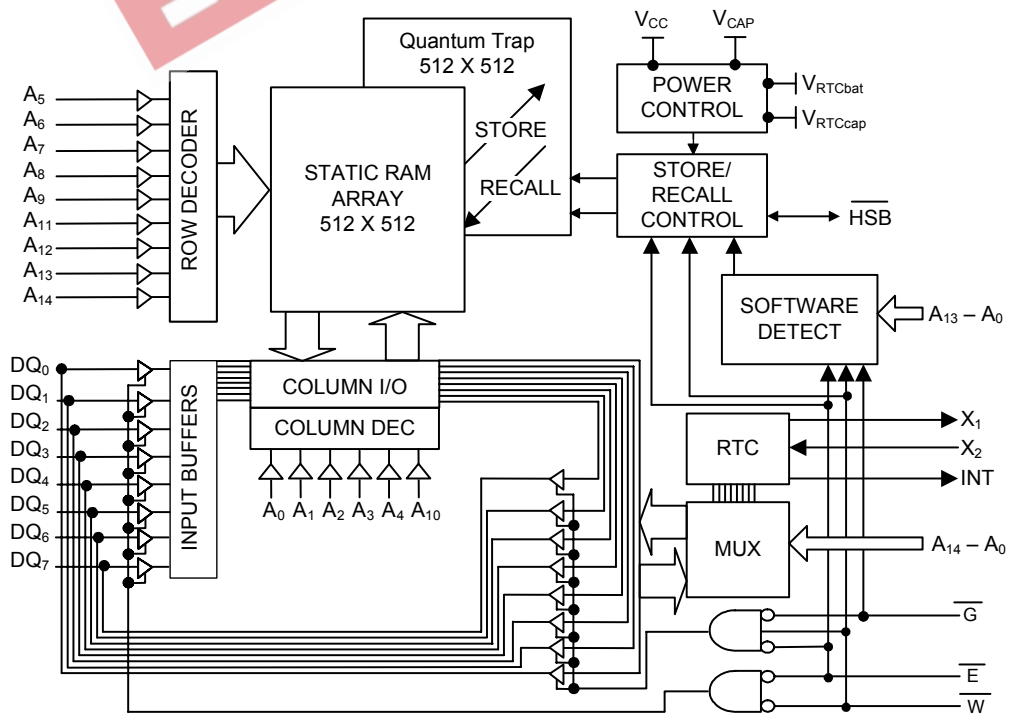
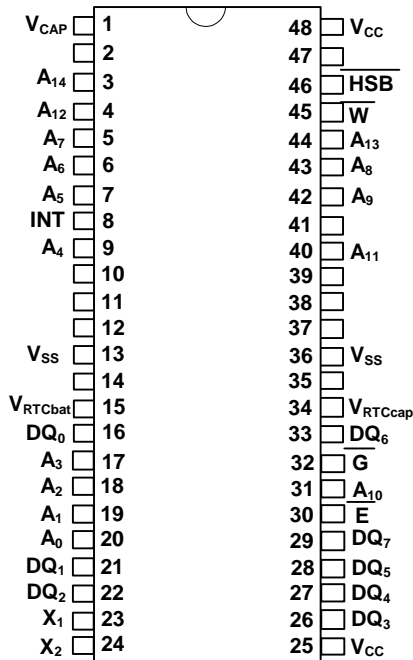
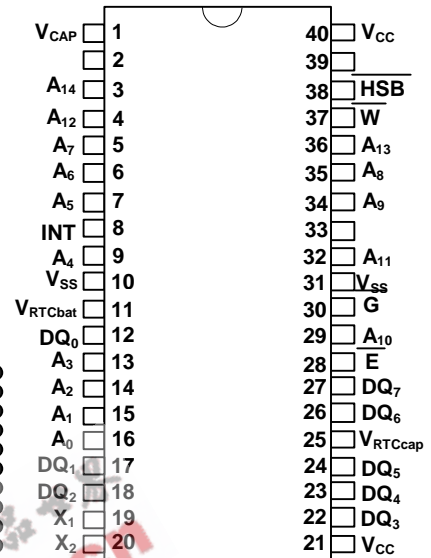

Figure 1. Block Diagram

PACKAGES



48 Pin SSOP



40 Pin PDIP



Relative PCB area usage.  
See website for detailed  
package size specifications.

PIN DESCRIPTIONS

Pin Name	I/O	Description
A <sub>14</sub> – A <sub>0</sub>	Input	Address: The 15 address inputs select one of 32,752 bytes in the nvSRAM array or one of 16 bytes in the clock register map.
DQ <sub>7</sub> – DQ <sub>0</sub>	I/O	Data: Bi-directional 8-bit data bus for accessing the nvSRAM array and RTC.
$\overline{E}$	Input	Chip Enable: The active low $\overline{E}$ input selects the device.
$\overline{W}$	Input	Write Enable: The active low $\overline{W}$ enables data on the DQ pins to be written to the address location latched by the falling edge of $\overline{E}$ .
$\overline{G}$	Input	Output Enable: The active low $\overline{G}$ input enables the data output buffers during read cycles. De-asserting $\overline{G}$ high causes the DQ pins to tri-state.
X <sub>1</sub>	Output	Crystal Connection, drives crystal on startup.
X <sub>2</sub>	Input	Crystal Connection for 32.768 kHz crystal.
V <sub>RTCCap</sub>	Power Supply	Capacitor supplied backup RTC supply voltage. (Left unconnected if V <sub>RTCbatt</sub> is used.)
V <sub>RTCbatt</sub>	Power Supply	Battery supplied backup RTC supply voltage. (Left unconnected if V <sub>RTCCap</sub> is used.)
V <sub>CC</sub>	Power Supply	Power 3.0V +20%, -10%
$\overline{HSB}$	I/O	Hardware Store Busy: When low this output indicates a Hardware Store is in progress. When pulled low external to the chip it will initiate a nonvolatile STORE operation. A weak internal pull up resistor keeps this pin high if not connected. (Connection Optional)
INT	Output	Interrupt Output: Can be programmed to respond to the clock alarm, the watchdog timer and the power monitor. Programmable to either active high (push/pull) or active low (open-drain).
V <sub>CAP</sub>	Power Supply	Autostore Capacitor: Supplies power to nvSRAM during power loss to store data from SRAM to nonvolatile elements.
V <sub>SS</sub>	Power Supply	Ground
(Blank)	No Connect	Unlabeled pins have no internal connection.

## ABSOLUTE MAXIMUM RATINGS<sup>a</sup>

Power Supply Voltage	-0.5V to +4.1V
Voltage on Input Relative to $V_{SS}$	-0.5V to ( $V_{CC} + 0.5V$ )
Voltage on Outputs	-0.5V to ( $V_{CC} + 0.5V$ )
Temperature under Bias	-55°C to 125°C
Junction Temperature	-55°C to 140°C
Storage Temperature	-65°C to 150°C
Power Dissipation	1W
DC Output Current (1 output at a time, 1s duration)	15mA

### Notes

a: Stresses greater than those listed under "Absolute Maximum Ratings" may cause permanent damage to the device. This is a stress rating only, and functional operation of the device at conditions above those indicated in the operational sections of this specification is not implied. Exposure to absolute maximum rating conditions for extended periods may affect reliability.

Package Thermal Characteristics see website: <http://www.simtek.com/>

## DC CHARACTERISTICS

Symbol	Parameter	Commercial		Industrial		Units	Notes
		MIN	MAX	MIN	MAX		
$I_{CC1}$	Average $V_{CC}$ Current		65 55 50		70 60 55	mA mA mA	$t_{AVAV} = 25ns$ $t_{AVAV} = 35ns$ $t_{AVAV} = 45ns$ Dependent on output loading and cycle rate. Values obtained without output loads.
$I_{CC2}$	Average $V_{CC}$ Current during STORE		3		3	mA	All Inputs Don't Care, $V_{CC} = \max$ Average current for duration of STORE cycle ( $t_{STORE}$ ).
$I_{CC3}$	Average $V_{CC}$ Current at $t_{AVAV} = 200ns$ 3V, 25°C, Typical		5		5	mA	$\overline{W} \geq (V_{CC} - 0.2V)$ All Others Inputs Cycling, at CMOS Levels. Dependent on output loading and cycle rate. Values obtained without output loads.
$I_{CC4}$	Average $V_{CAP}$ Current during AutoStore™ Cycle		3		3	mA	All Inputs Don't Care Average current for duration of STORE cycle ( $t_{STORE}$ ).
$I_{SB}$	$V_{CC}$ Standby Current (Standby, Stable CMOS Input Levels)		2		2	mA	$\overline{E} \geq (V_{CC} - 0.2V)$ All Others $V_{IN} \leq 0.2V$ or $\geq (V_{CC} - 0.2V)$ Standby current level after nonvolatile cycle is complete.
$I_{ILK}$	Input Leakage Current		$\pm 1$		$\pm 1$	$\mu A$	$V_{CC} = \max$ $V_{IN} = V_{SS}$ to $V_{CC}$
$I_{OLK}$	Off-State Output Leakage Current		$\pm 1$		$\pm 1$	$\mu A$	$V_{CC} = \max$ $V_{IN} = V_{SS}$ to $V_{CC}$ , $\overline{E}$ or $\overline{G} \geq V_{IH}$
$V_{IH}$	Input Logic "1" Voltage	2.0	$V_{CC} + 0.3$	2.0	$V_{CC} + 0.3$	V	All Inputs
$V_{IL}$	Input Logic "0" Voltage	$V_{SS} - 0.5$	0.8	$V_{SS} - 0.5$	0.8	V	All Inputs
$V_{OH}$	Output Logic "1" Voltage	2.4		2.4		V	$I_{OUT} = -2mA$
$V_{OL}$	Output Logic "0" Voltage		0.4		0.4	V	$I_{OUT} = 4mA$
$T_A$	Operating Temperature	0	70	-40	85	°C	
$V_{CC}$	Operating Voltage	2.7	3.6	2.7	3.6	V	3.0V +20%, -10%
$V_{CAP}$	Storage Capacitor	17	57	17	57	$\mu F$	Between Vcap pin and Vss, 6.3V rated.

**AC TEST CONDITIONS**

Input Pulse Levels	0V to 3V
Input Rise and Fall Times	≤ 5ns
Input and Output Timing Reference Levels	1.5V
Output Load	See Figure 2 and Figure 3

**CAPACITANCE<sup>b</sup>** (T<sub>A</sub> = 25°C, f = 1.0MHz)

SYMBOL	PARAMETER	MAX	UNITS	CONDITIONS
C <sub>IN</sub>	Input Capacitance	7	pF	ΔV = 0 to 3V
C <sub>OUT</sub>	Output Capacitance	7	pF	ΔV = 0 to 3V

Notes

b: These parameters are guaranteed but not tested

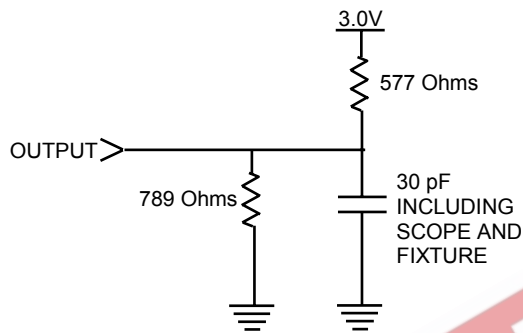

Figure 2. AC Output Loading

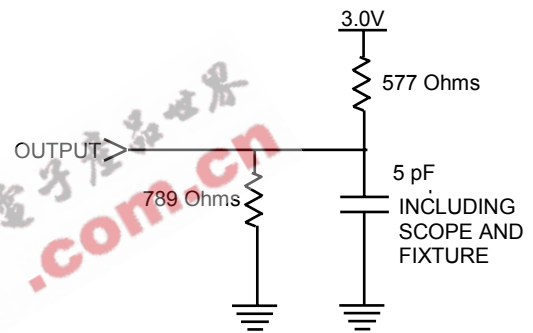
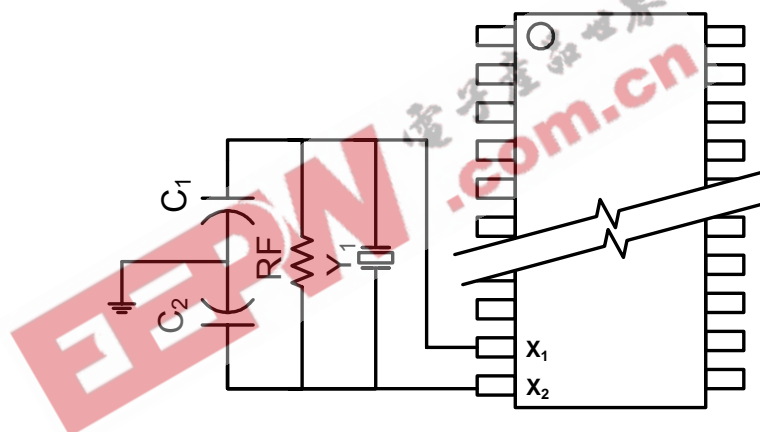

Figure 3. AC Output Loading, for tristate specs ( t<sub>HZ</sub>, t<sub>LZ</sub>, t<sub>WLQZ</sub>, t<sub>WHQZ</sub>, t<sub>GLQX</sub>, t<sub>GHQZ</sub> )

## RTC DC CHARACTERISTICS

Symbol	Parameter	Commercial		Industrial		Units	Notes
		MIN	MAX	MIN	MAX		
$I_{BAK}$	RTC Backup Current	-	300	-	350	nA	From either $V_{RTCcap}$ or $V_{RTCbat}$
$V_{RTCbat}$	RTC Battery Pin Voltage	1.8	3.3	1.8	3.3	V	Typical = 3.0 Volts during normal operation
$V_{RTCcap}$	RTC Capacitor Pin Voltage	1.2	2.7	1.2	2.7	V	Typical = 2.4 Volts during normal operation
$t_{OSCS}$	RTC Oscillator time to start	-	1	-	1	min	@ MIN Temperature from Power up or Enable
		-	10	-	10	sec	@25°C from Power up or Enable

## RTC RECOMMENDED COMPONENT CONFIGURATION



### Recommended Values

$$Y_1 = 32.768 \text{ KHz}$$

$$R_F = 10 \text{ M Ohm}$$

$$C_1 = 2.2 \text{ pF}$$

$$C_2 = 47 \text{ pF}$$

Figure 4. RTC COMPONENT CONFIGURATION

SRAM READ CYCLES #1 & #2

NO.	SYMBOLS			PARAMETER	STK17T88-25		STK17T88-35		STK17T88-45		UNITS
	#1	#2	Alt.		MIN	MAX	MIN	MAX	MIN	MAX	
1		$t_{ELQV}$	$t_{ACS}$	Chip Enable Access Time		25		35		45	ns
2	$t_{AVAV}^c$	$t_{AVAV}^c$	$t_{RC}$	Read Cycle Time	25		35		45		ns
3	$t_{AVQV}^d$		$t_{AA}$	Address Access Time		25		35		45	ns
4		$t_{GLQV}$	$t_{OE}$	Output Enable to Data Valid		12		15		20	ns
5	$t_{XQX}^d$		$t_{OH}$	Output Hold after Address Change	3		3		3		ns
6		$t_{ELQX}$	$t_{LZ}$	Chip Enable to Output Active	3		3		3		ns
7		$t_{EHQZ}^e$	$t_{HZ}$	Chip Disable to Output Inactive		10		13		15	ns
8		$t_{GLQX}$	$t_{OLZ}$	Output Enable to Output Active	0		0		0		ns
9		$t_{GHQZ}^e$	$t_{OHZ}$	Output Disable to Output Inactive		10		13		15	ns
10		$t_{ELICC}^b$	$t_{PA}$	Chip Enable to Power Active	0		0		0		ns
11		$t_{EHICC}^b$	$t_{PS}$	Chip Disable to Power Standby		25		35		45	ns

Notes

- c:  $\overline{W}$  must be high during SRAM READ cycles
- d: Device is continuously selected with  $\overline{E}$  and  $\overline{G}$  both low
- e: Measured  $\pm 200mV$  from steady state output voltage
- f:  $\overline{HSB}$  must remain high during READ and WRITE cycles.

SRAM READ CYCLE #1: Address Controlled<sup>c,d,f</sup>

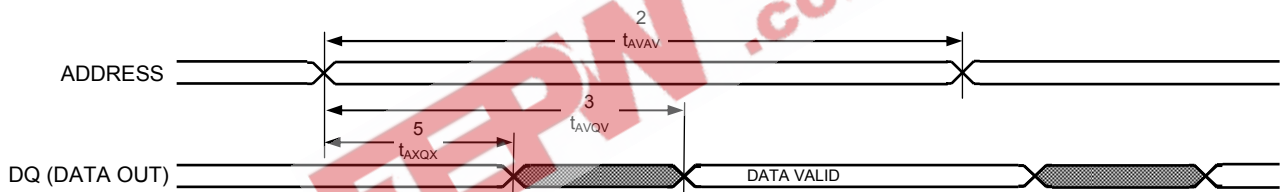

SRAM READ CYCLE #2:  $\overline{E}$  Controlled<sup>c,f</sup>

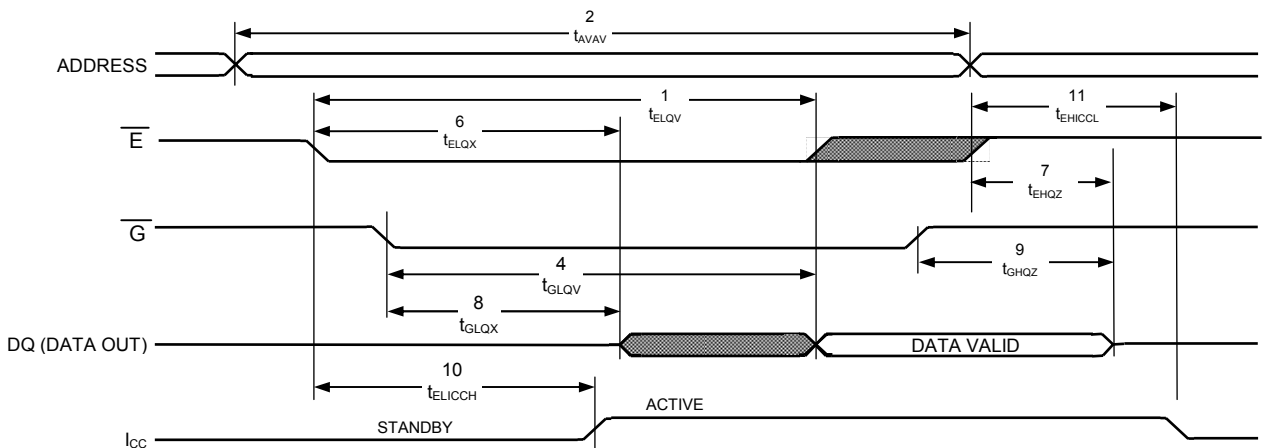

SRAM WRITE CYCLES #1 & #2

NO.	SYMBOLS			PARAMETER	STK17T88-25		STK17T88-35		STK17T88-45		UNITS
	#1	#2	Alt.		MIN	MAX	MIN	MAX	MIN	MAX	
12	$t_{AVAV}$	$t_{AVAV}$	$t_{WC}$	Write Cycle Time	25		35		45		ns
13	$t_{WLWH}$	$t_{WLEH}$	$t_{WP}$	Write Pulse Width	20		25		30		ns
14	$t_{ELWH}$	$t_{ELEH}$	$t_{CW}$	Chip Enable to End of Write	20		25		30		ns
15	$t_{DVWH}$	$t_{DVEH}$	$t_{DW}$	Data Set-up to End of Write	10		12		15		ns
16	$t_{WHDX}$	$t_{EHDX}$	$t_{DH}$	Data Hold after End of Write	0		0		0		ns
17	$t_{AVWH}$	$t_{AVEH}$	$t_{AW}$	Address Set-up to End of Write	20		25		30		ns
18	$t_{AVWL}$	$t_{AVEL}$	$t_{AS}$	Address Set-up to Start of Write	0		0		0		ns
19	$t_{WHAX}$	$t_{EHAX}$	$t_{WR}$	Address Hold after End of Write	0		0		0		ns
20	$t_{WLOZ}^{eg}$		$t_{WZ}$	Write Enable to Output Disable		10		13		15	ns
21	$t_{WHQX}$		$t_{OW}$	Output Active after End of Write	3		3		3		ns

Notes

g: If  $\overline{W}$  is low when  $\overline{E}$  goes low, the outputs remain in the high-impedance state.

h:  $\overline{E}$  or  $\overline{W}$  must be  $\geq V_{IH}$  during address transitions.

SRAM WRITE CYCLE #1:  $\overline{W}$  Controlled<sup>h,f</sup>

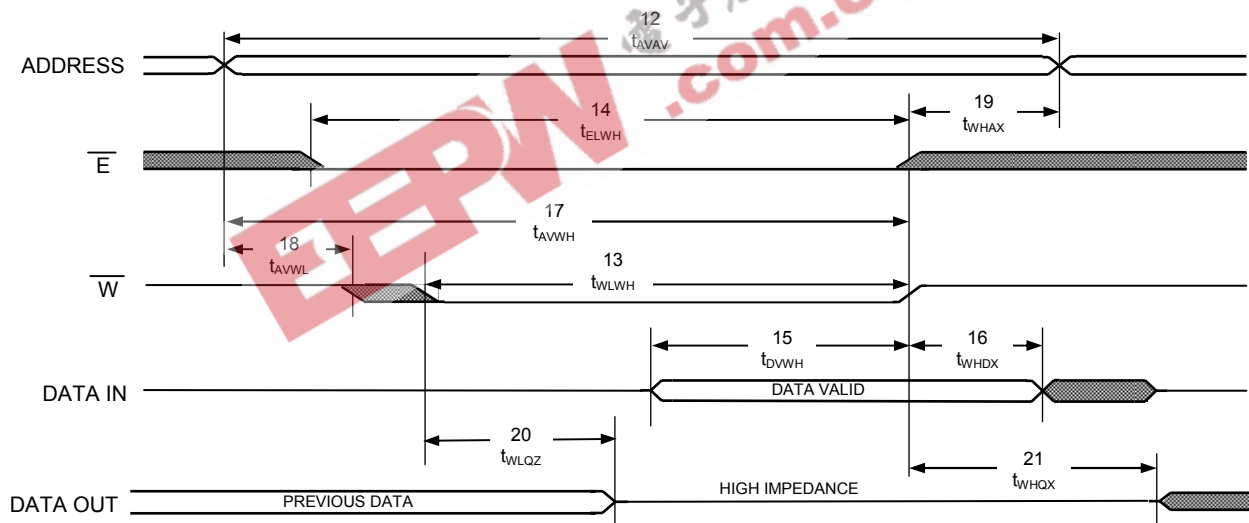

SRAM WRITE CYCLE #2:  $\overline{E}$  Controlled<sup>h,f</sup>

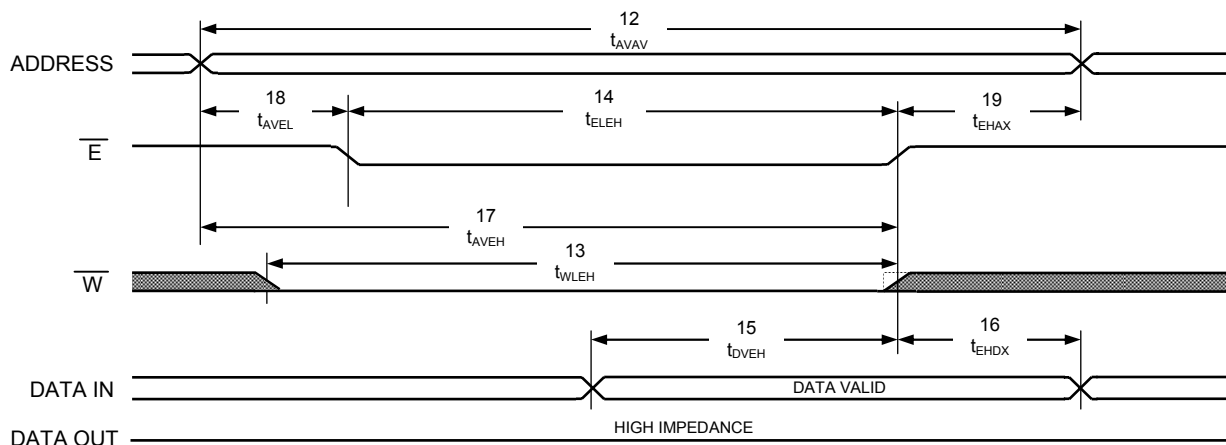

**MODE SELECTION**

$\overline{E}$	$\overline{W}$	$\overline{G}$	A <sub>13</sub> - A <sub>0</sub>	MODE	I/O	POWER	NOTES
H	X	X	X	Not Selected	Output High Z	Standby	
L	H	L	X	Read SRAM	Output Data	Active	
L	L	X	X	Write SRAM	Input Data	Active	
L	H	L	0x0E38 0x31C7 0x03E0 0x3C1F 0x303F 0x03F8	Read SRAM Read SRAM Read SRAM Read SRAM Read SRAM Autostore Disable	Output Data Output Data Output Data Output Data Output Data Output Data	Active	i, j, k
L	H	L	0x0E38 0x31C7 0x03E0 0x3C1F 0x303F 0x07F0	Read SRAM Read SRAM Read SRAM Read SRAM Read SRAM Autostore Enable	Output Data Output Data Output Data Output Data Output Data Output Data	Active	i, j, k
L	H	L	0x0E38 0x31C7 0x03E0 0x3C1F 0x303F 0x0FC0	Read SRAM Read SRAM Read SRAM Read SRAM Read SRAM Nonvolatile Store	Output Data Output Data Output Data Output Data Output Data Output High Z	Active ICC2	i, j, k
L	H	L	0x0E38 0x31C7 0x03E0 0x3C1F 0x303F 0x0C63	Read SRAM Read SRAM Read SRAM Read SRAM Read SRAM Nonvolatile Recall	Output Data Output Data Output Data Output Data Output Data Output High Z	Active	i, j, k

Notes

- i: The six consecutive addresses must be in the order listed.  $\overline{W}$  must be high during all six consecutive cycles to enable a nonvolatile cycle.
- j: While there are 15 addresses on the STK17T88, only the lower 14 are used to control software modes
- k: I/O state depends on the state of  $\overline{G}$ . The I/O table shown assumes  $\overline{G}$  low.



### AutoStore™ /POWER-UP RECALL

NO.	SYMBOLS		PARAMETER	STK17T88		UNITS	NOTES
	Standard	Alternate		MIN	MAX		
22	$t_{HRECALL}$		Power-up RECALL Duration		20	ms	l
23	$t_{STORE}$	$t_{HLHZ}$	STORE Cycle Duration		12.5	ms	m
24	$V_{SWITCH}$		Low Voltage Trigger Level	2.55	2.65	V	
25	$t_{VCCRISE}$		$V_{CC}$ Rise Time	150		$\mu$ s	

Notes

l:  $t_{HRECALL}$  starts from the time  $V_{CC}$  rises above  $V_{SWITCH}$

m: If an SRAM WRITE has not taken place since the last nonvolatile cycle, no STORE will take place

### AutoStore™/POWER-UP RECALL

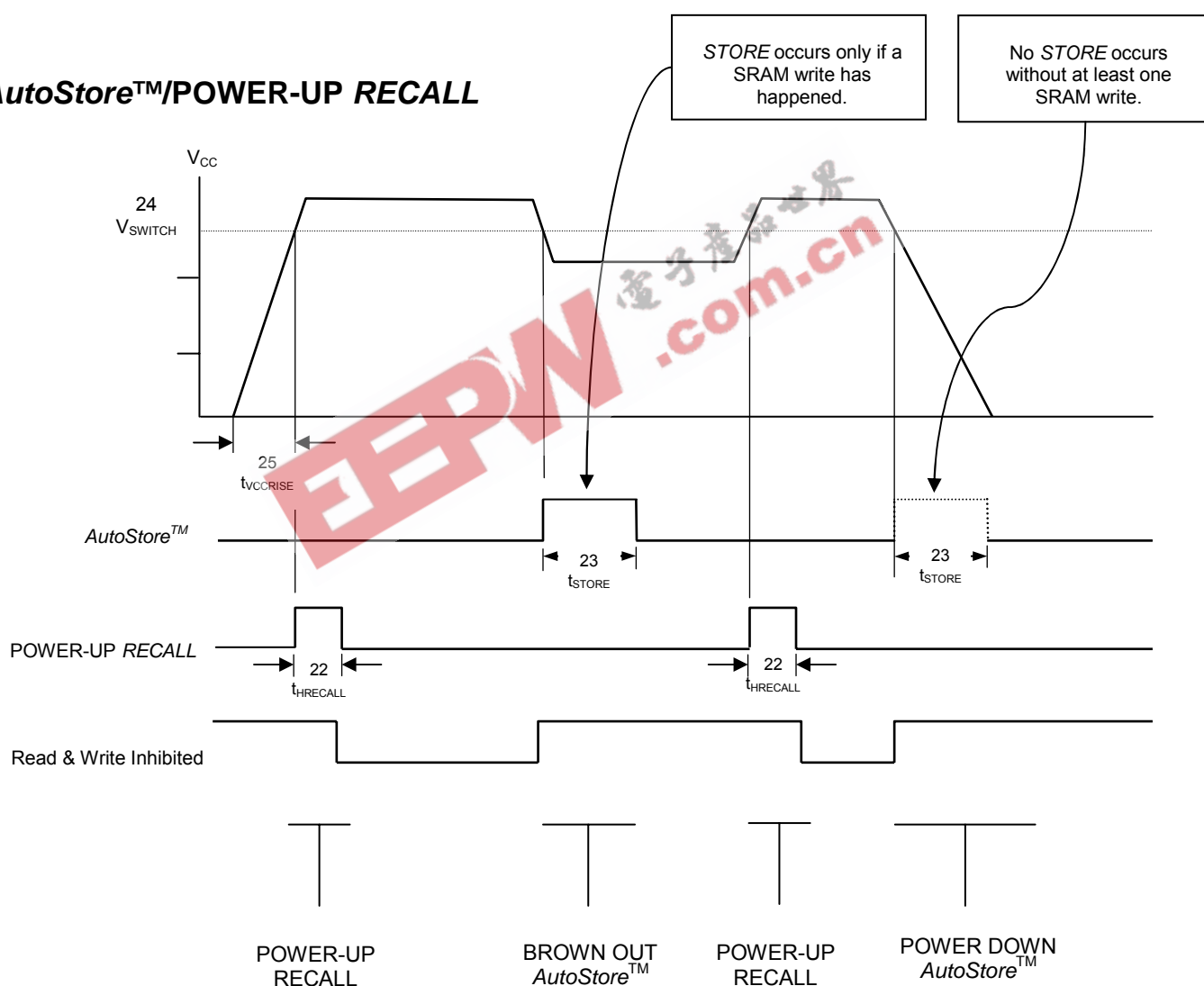

Note: Read and Write cycles will be ignored during STORE, RECALL and while  $V_{CC}$  is below  $V_{SWITCH}$ .

**SOFTWARE-CONTROLLED STORE/RECALL CYCLE<sup>n,o</sup>**

NO.	SYMBOLS			PARAMETER	STK17T88-25		STK17T88-35		STK17T88-45		UNITS	NOTES
	$\overline{E}$ cont	$\overline{G}$ cont	Alt.		MIN	MAX	MIN	MAX	MIN	MAX		
26	$t_{AVAV}$	$t_{AVAV}$	$t_{RC}$	STORE/RECALL Initiation Cycle Time	25		35		45		ns	<sup>o</sup>
27	$t_{AVEL}$	$t_{AVGL}$	$t_{AS}$	Address Set-up Time	0		0		0		ns	
28	$t_{ELEH}$	$t_{GLGH}$	$t_{CW}$	Clock Pulse Width	20		25		30		ns	
29	$t_{ELAX}$	$t_{GLAX}$		Address Hold Time	20		20		20		ns	
30	$t_{RECALL}$	$t_{RECALL}$		RECALL Duration		40		40		40	$\mu$ s	

Notes

- n: The software sequence is clocked with  $\overline{E}$  controlled READs or  $\overline{G}$  controlled READs.
- o: The six consecutive addresses must be read in the order listed in the Mode Selection Table.  $\overline{W}$  must be high during all six consecutive cycles.

**SOFTWARE STORE/RECALL CYCLE:  $\overline{E}$  Controlled<sup>o</sup>**

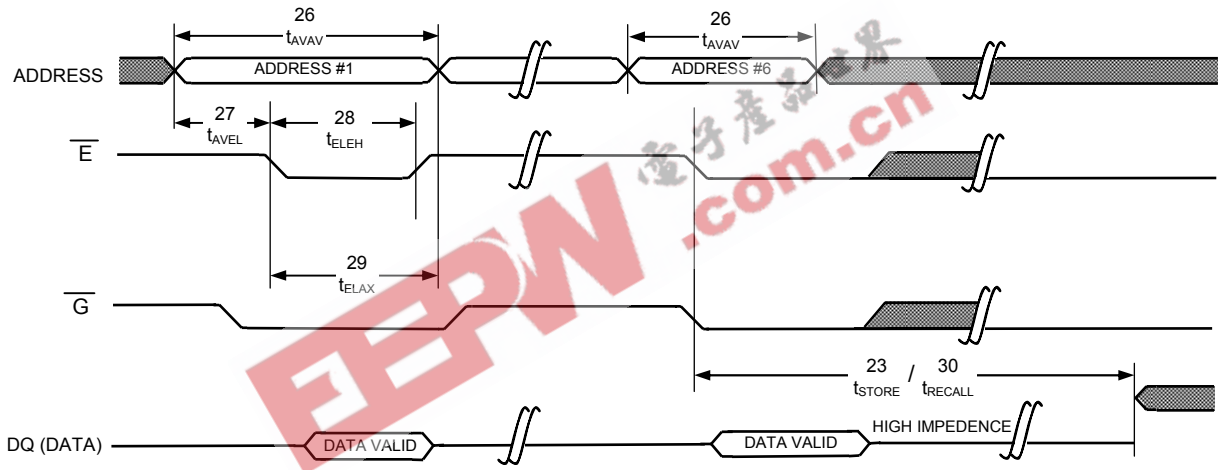

**SOFTWARE STORE/RECALL CYCLE:  $\overline{G}$  Controlled<sup>o</sup>**

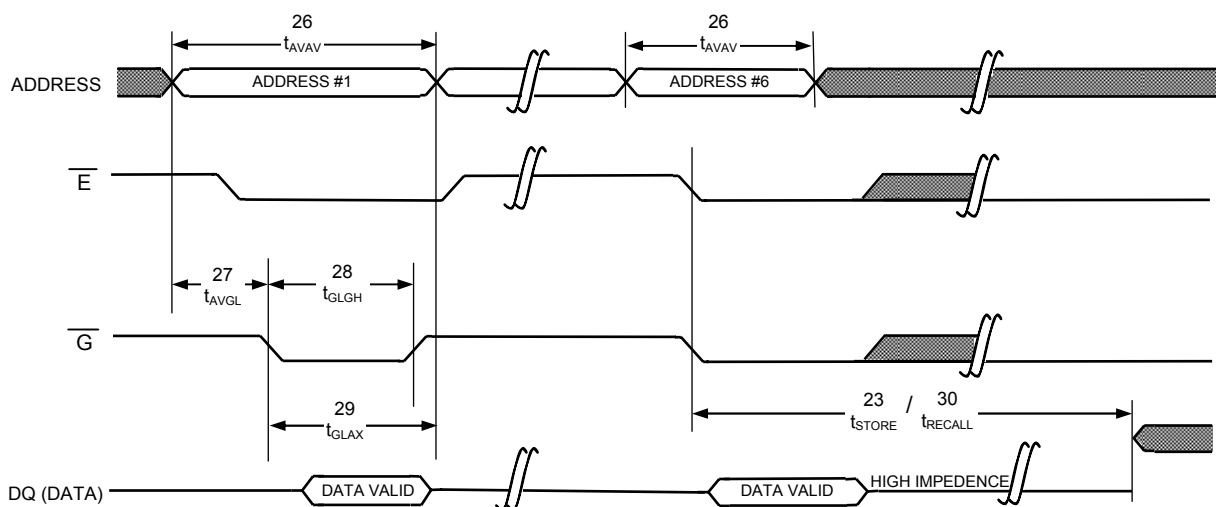

### HARDWARE STORE CYCLE

NO.	SYMBOLS		PARAMETER	STK17T88		UNITS	NOTES
	Standard	Alternate		MIN	MAX		
31	$t_{\text{DELAY}}$	$t_{\text{HLOZ}}$	Time Allowed to Complete SRAM Cycle	1		$\mu\text{s}$	p
32	$t_{\text{HLHX}}$		Hardware STORE Pulse Width	15		ns	
33	$t_{\text{HLBL}}$		Hardware STORE Low to STORE Busy		300	ns	

Notes

p: Read and Write cycles in progress before  $\overline{\text{HSB}}$  is asserted are given this amount of time to complete.

### HARDWARE STORE CYCLE

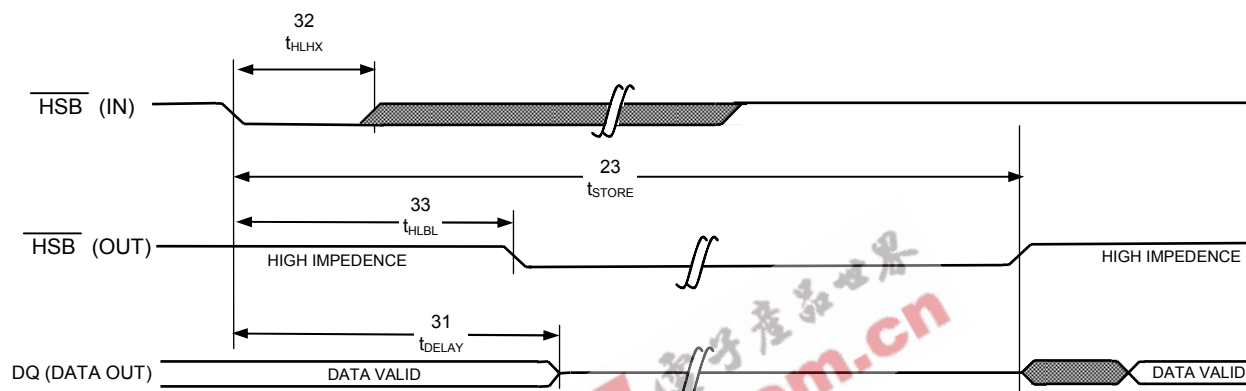

# DEVICE OPERATION

## nvSRAM

The STK17T88 nvSRAM is made up of two functional components paired in the same physical cell. These are a SRAM memory cell and a nonvolatile *QuantumTrap™* cell. The SRAM memory cell operates as a standard fast static RAM. Data in the SRAM can be transferred to the nonvolatile cell (the *STORE* operation), or from the nonvolatile cell to SRAM (the *RECALL* operation). This unique architecture allows all cells to be stored and recalled in parallel. During the *STORE* and *RECALL* operations SRAM READ and WRITE operations are inhibited. The STK17T88 supports unlimited reads and writes just like a typical SRAM. In addition, it provides unlimited *RECALL* operations from the nonvolatile cells and up to 1 million *STORE* operations.

## SRAM READ

The STK17T88 performs a READ cycle whenever  $\overline{E}$  and  $\overline{G}$  are low while  $\overline{W}$  and  $\overline{HSB}$  are high. The address specified on pins A<sub>14-0</sub> determines which of the 32,752 data bytes will be accessed. When the READ is initiated by an address transition, the outputs will be valid after a delay of  $t_{AVQV}$  (READ cycle #1). If the READ is initiated by  $\overline{E}$  or  $\overline{G}$ , the outputs will be valid at  $t_{ELQV}$  or at  $t_{GLQV}$ , whichever is later (READ cycle #2). The data outputs will repeatedly respond to address changes within the  $t_{AVQV}$  access time without the need for transitions on any control input pins, and will remain valid until another address change or until  $\overline{E}$  or  $\overline{G}$  is brought high, or  $\overline{W}$  or  $\overline{HSB}$  is brought low.

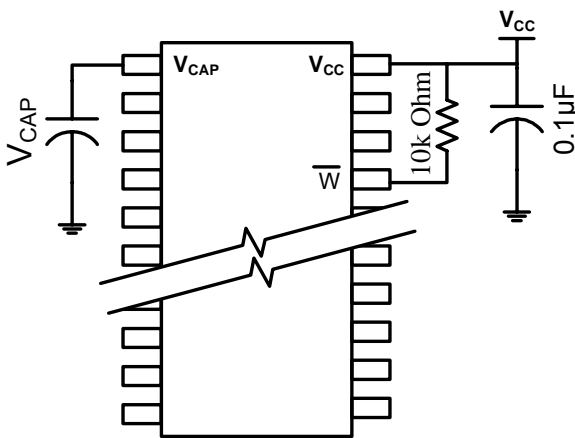

Figure 5: *AutoStore™* Mode

## SRAM WRITE

A WRITE cycle is performed whenever  $\overline{E}$  and  $\overline{W}$  are low and  $\overline{HSB}$  is high. The address inputs must be stable prior to entering the WRITE cycle and must remain stable until either  $\overline{E}$  or  $\overline{W}$  goes high at the end of the cycle. The data on the common I/O pins DQ<sub>0-7</sub> will be written into the memory if it is valid  $t_{DVWH}$  before the end of a  $\overline{W}$  controlled WRITE or  $t_{DVEH}$  before the end of an  $\overline{E}$  controlled WRITE.

It is recommended that  $\overline{G}$  be kept high during the entire WRITE cycle to avoid data bus contention on common I/O lines. If  $\overline{G}$  is left low, internal circuitry will turn off the output buffers  $t_{WLQZ}$  after  $\overline{W}$  goes low.

## *AutoStore™* OPERATION

The STK17T88 stores data to nvSRAM using one of three storage operations. These three operations are Hardware Store, activated by  $\overline{HSB}$ , Software Store, activated by an address sequence, and *AutoStore™*, on device power down.

*AutoStore™* operation is a unique feature of Simtek *QuantumTrap™* technology and is enabled by default on the STK17T88.

During normal operation, the device will draw current from Vcc to charge a capacitor connected to the Vcap pin. This stored charge will be used by the chip to perform a single STORE operation. If the voltage on the Vcc pin drops below Vswitch, the part will automatically disconnect the Vcap pin from Vcc. A STORE operation will be initiated with power provided by the Vcap capacitor.

Figure 5 shows the proper connection of the storage capacitor (Vcap) for automatic store operation. Refer to the DC CHARACTERISTICS table for the size of Vcap. The voltage on the Vcap pin is driven to 5V by a charge pump internal to the chip. A pull up should be placed on  $\overline{W}$  to hold it inactive during power up.

To reduce unneeded nonvolatile stores, *AutoStore™* and Hardware Store operations will be ignored unless at least one WRITE operation has taken place since the most recent *STORE* or *RECALL* cycle. Software initiated *STORE* cycles are performed regardless of whether a WRITE operation has taken place. The  $\overline{HSB}$  signal can be monitored by the system to detect an *AutoStore™* cycle is in progress.

## HARDWARE STORE ( $\overline{\text{HSB}}$ ) OPERATION

The STK17T88 provides the  $\overline{\text{HSB}}$  pin for controlling and acknowledging the *STORE* operations. The HSB pin can be used to request a hardware *STORE* cycle. When the  $\overline{\text{HSB}}$  pin is driven low, the STK17T88 will conditionally initiate a *STORE* operation after  $t_{\text{DELAY}}$ . An actual *STORE* cycle will only begin if a *WRITE* to the SRAM took place since the last *STORE* or *RECALL* cycle. The  $\overline{\text{HSB}}$  pin also acts as an open drain driver that is internally driven low to indicate a busy condition while the *STORE* (initiated by any means) is in progress.

SRAM READ and WRITE operations that are in progress when  $\overline{\text{HSB}}$  is driven low by any means are given time to complete before the *STORE* operation is initiated. After  $\overline{\text{HSB}}$  goes low, the STK17T88 will continue SRAM operations for  $t_{\text{DELAY}}$ . During  $t_{\text{DELAY}}$ , multiple SRAM READ operations may take place. If a *WRITE* is in progress when  $\overline{\text{HSB}}$  is pulled low it will be allowed a time,  $t_{\text{DELAY}}$ , to complete. However, any SRAM *WRITE* cycles requested after  $\overline{\text{HSB}}$  goes low will be inhibited until  $\overline{\text{HSB}}$  returns high.

During any *STORE* operation, regardless of how it was initiated, the STK17T88 will continue to drive the  $\overline{\text{HSB}}$  pin low, releasing it only when the *STORE* is complete. Upon completion of the *STORE* operation the STK17T88 will remain disabled until the  $\overline{\text{HSB}}$  pin returns high.

If  $\overline{\text{HSB}}$  is not used, it should be left unconnected.

## HARDWARE RECALL (POWER-UP)

During power up, or after any low-power condition ( $V_{\text{CC}} < V_{\text{SWITCH}}$ ), an internal *RECALL* request will be latched. When  $V_{\text{CC}}$  once again exceeds the sense voltage of  $V_{\text{SWITCH}}$ , a *RECALL* cycle will automatically be initiated and will take  $t_{\text{HRECALL}}$  to complete.

## SOFTWARE STORE

Data can be transferred from the SRAM to the nonvolatile memory by a software address sequence. The STK17T88 software *STORE* cycle is initiated by executing sequential  $\overline{\text{E}}$  controlled READ cycles from six specific address locations in exact order. During the *STORE* cycle an erase of the previous nonvolatile data is first performed, followed by a program of the nonvolatile elements. Once a *STORE* cycle is initiated, further input and output are disabled until the cycle is completed.

Because a sequence of READs from specific addresses is used for *STORE* initiation, it is important that no other READ or WRITE accesses intervene in the sequence, or the sequence will be aborted and no *STORE* or *RECALL* will take place.

To initiate the software *STORE* cycle, the following READ sequence must be performed:

1. Read address	0x0E38	Valid READ
2. Read address	0x31C7	Valid READ
3. Read address	0x03E0	Valid READ
4. Read address	0x3C1F	Valid READ
5. Read address	0x303F	Valid READ
6. Read address	0x0FC0	Initiate <i>STORE</i> cycle

The software sequence may be clocked with  $\overline{\text{E}}$  controlled READs or  $\overline{\text{C}}$  controlled READs.

Once the sixth address in the sequence has been entered, the *STORE* cycle will commence and the chip will be disabled. It is important that READ cycles and not WRITE cycles be used in the sequence, although it is not necessary that  $\overline{\text{C}}$  be low for the sequence to be valid. After the  $t_{\text{STORE}}$  cycle time has been fulfilled, the SRAM will again be activated for READ and WRITE operation.

## SOFTWARE RECALL

Data can be transferred from the nonvolatile memory to the SRAM by a software address sequence. A software *RECALL* cycle is initiated with a sequence of READ operations in a manner similar to the software *STORE* initiation. To initiate the *RECALL* cycle, the following sequence of  $\overline{\text{E}}$  controlled READ operations must be performed:

1. Read address	0x0E38	Valid READ
2. Read address	0x31C7	Valid READ
3. Read address	0x03E0	Valid READ
4. Read address	0x3C1F	Valid READ
5. Read address	0x303F	Valid READ
6. Read address	0x0C63	Initiate <i>RECALL</i> cycle

Internally, *RECALL* is a two-step procedure. First, the SRAM data is cleared, and second, the nonvolatile information is transferred into the SRAM cells. After the  $t_{RECALL}$  cycle time the SRAM will once again be ready for READ and WRITE operations. The *RECALL* operation in no way alters the data in the nonvolatile elements.

**PREVENTING AUTOSTORE™**

The *AutoStore*™ function can be disabled by initiating an *AutoStore Disable* sequence. A sequence of read operations is performed in a manner similar to the software *STORE* initiation. To initiate the *AutoStore Disable* sequence, the following sequence of  $\overline{E}$  controlled read operations must be performed:

- 1. Read address 0x0E38 Valid READ
- 2. Read address 0x31C7 Valid READ
- 3. Read address 0x03E0 Valid READ
- 4. Read address 0x3C1F Valid READ
- 5. Read address 0x303F Valid READ
- 6. Read address 0x03F8 *AutoStore Disable*

The *AutoStore*™ can be re-enabled by initiating an *AutoStore Enable* sequence. A sequence of read operations is performed in a manner similar to the software *RECALL* initiation. To initiate the *AutoStore Enable* sequence, the following sequence of  $\overline{E}$  controlled read operations must be performed:

- 1. Read address 0x0E38 Valid READ
- 2. Read address 0x31C7 Valid READ
- 3. Read address 0x03E0 Valid READ
- 4. Read address 0x3C1F Valid READ
- 5. Read address 0x303F Valid READ
- 6. Read address 0x07F0 *AutoStore Enable*

If the *AutoStore*™ function is disabled or re-enabled a manual *STORE* operation (Hardware or Software) needs to be issued to save the *AutoStore* state through subsequent power down cycles. The part comes from the factory with *AutoStore*™ enabled.

**DATA PROTECTION**

The STK17T88 protects data from corruption during low-voltage conditions by inhibiting all externally initiated *STORE* and *WRITE* operations. The low-voltage condition is detected when  $V_{CC} < V_{SWITCH}$ .

If the STK17T88 is in a *WRITE* mode (both  $\overline{E}$  and  $\overline{W}$  low) at power-up, after a *RECALL*, or after a *STORE*, the *WRITE* will be inhibited until a negative transition on  $\overline{E}$  or  $\overline{W}$  is detected. This protects against inadvertent writes during power up or brown out conditions.

**NOISE CONSIDERATIONS**

The STK17T88 is a high-speed memory and so must have a high-frequency bypass capacitor of approximately 0.1µF connected between  $V_{CC}$  and  $V_{SS}$ , using leads and traces that are as short as possible. As with all high-speed CMOS ICs, careful routing of power, ground and signals will reduce circuit noise.

**LOW AVERAGE ACTIVE POWER**

CMOS technology provides the STK17T88 this the benefit of drawing significantly less current when it is cycled at times longer than 50ns. Figure 6 shows the relationship between  $I_{CC}$  and READ/WRITE cycle time. Worst-case current consumption is shown for commercial temperature range,  $V_{CC} = 3.6V$ , and chip enable at maximum frequency. Only standby current is drawn when the chip is disabled. The overall average current drawn by the STK17T88 depends on the following items:

- 1. The duty cycle of chip enable.
- 2. The overall cycle rate for accesses.
- 3. The ratio of READs to WRITEs.
- 4. The operating temperature.
- 5. The  $V_{CC}$  level.
- 6. I/O loading.

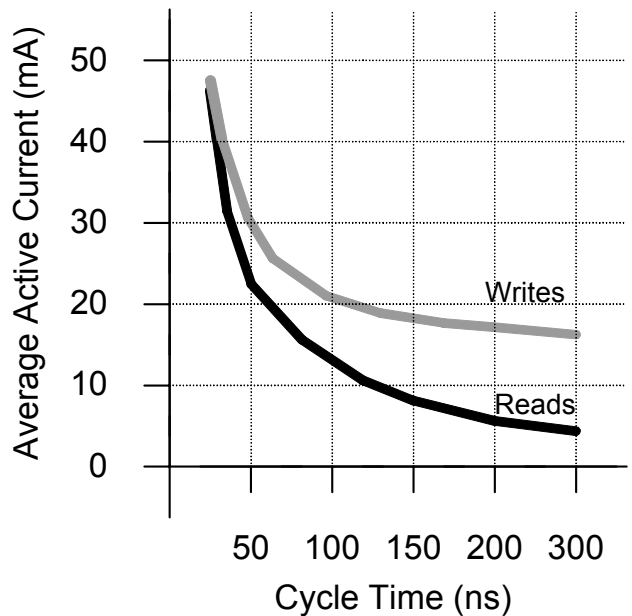

Figure 6 Current vs. Cycle time

## REAL TIME CLOCK OPERATION

### nvTIME OPERATION

The STK17T88 offers internal registers that contain Clock, Alarm, Watchdog, Interrupt, and Control functions. Internal double buffering of the clock and the clock/timer information registers prevents accessing transitional internal clock data during a read or write operation. Double buffering also circumvents disrupting normal timing counts or clock accuracy of the internal clock while accessing clock data. Clock and Alarm Registers store data in BCD format.

### CLOCK OPERATIONS

The clock registers maintain time up to 9,999 years in one second increments. The user can set the time to any calendar time and the clock automatically keeps track of days of the week and month, leap years and century transitions. There are eight registers dedicated to the clock functions which are used to set time with a write cycle and to read time during a read cycle. These registers contain the Time of Day in BCD format. Bits defined as "X" are currently not used and are reserved for future use by Simtek.

### READING THE CLOCK

While the double-buffered RTC register structure reduces the chance of reading incorrect data from the clock, the user should halt internal updates to the STK17T88 clock registers before reading clock data to prevent the reading of data in transition. Stopping the internal register updates does not affect clock accuracy.

The updating process is stopped by writing a "1" to the read bit "R" (in the flags register at 0x7FF0), and will not restart until a "0" is written to the read bit. The RTC registers can then be read while the internal clock continues to run.

Within 20ms after a "0" is written to the read bit, all STK17T88 registers are simultaneously updated.

### SETTING THE CLOCK

Setting the write bit "W" (in the flags register at 0x7FF0) to a "1" halts updates to the STK17T88 registers. The correct day, date and time can then be written into the registers in 24-hour BCD format. The time written is referred to as the "Base Time." This value is stored in nonvolatile registers and used in calculation of the current time. Resetting the write bit to "0" transfers those values to the actual clock counters, after which the clock resumes normal operation.

### BACKUP POWER

The RTC in the STK17T88 is intended for permanently powered operation. Either the  $V_{RTCcap}$  or  $V_{RTCbatt}$  pin is connected depending on whether a capacitor or battery is chosen for the application. When primary power,  $V_{CC}$ , fails and drops below  $V_{switch}$  the device will switch to the backup power supply.

The clock oscillator uses very little current, which maximizes the backup time available from the backup source. Regardless of clock operation with the primary source removed, the data stored in nvSRAM is secure, having been stored in the nonvolatile elements as power was lost. Factors to be considered when choosing a backup power source include: the expected duration of power outages and the cost trade-off of using a battery versus a capacitor.

During backup operation the STK17T88 consumes a maximum of 300 nanoamps at 2 volts. Capacitor or battery values should be chosen according to the application. Backup time values based on maximum current specs are shown below. Nominal times are approximately 3 times longer.

Capacitor Value	Backup Time
0.1 F	72 hours
0.47 F	14 days
1.0 F	30 days

Using a capacitor has the obvious advantage of recharging the backup source each time the system is powered up.

If a battery is used, a 3V lithium is recommended and the STK17T88 will only source current from the battery when the primary power is removed. The battery will not, however, be recharged at any time by the STK17T88. The battery capacity should be chosen for total anticipated cumulative down-time required over the life of the system.

### STOPPING AND STARTING THE OSCILLATOR

The  $\overline{\text{OSCEN}}$  bit in calibration register at 0x7FF8 controls the starting and stopping of the oscillator. This bit is nonvolatile and shipped to customers in the "enabled" (set to 0) state. To preserve battery life while system is in storage  $\overline{\text{OSCEN}}$  should be set to a 1. This will turn off the oscillator circuit extending the battery life. If the  $\overline{\text{OSCEN}}$  bit goes from disabled to enabled, it will take approximately 5 seconds (10 seconds max) for the oscillator to start.

The STK17T88 has the ability to detect oscillator failure. This is recorded in the OSCF (Oscillator Failed bit) of the flags register at address 0x7FF0. When the device is powered on ( $V_{CC}$  goes above  $V_{\text{switch}}$ ) the  $\overline{\text{OSCEN}}$  bit is checked for "enabled" status. If the  $\overline{\text{OSCEN}}$  bit is enabled and the oscillator is not active, the OSCF bit is set. The user should check for this condition and then write a 0 to clear the flag. It should be noted that in addition to setting the OSCF flag bit, the time registers are reset to the "Base Time" (see the section "Setting the Clock"), which is the value last written to the timekeeping registers. The Control/Calibration register and the  $\overline{\text{OSCEN}}$  bit are not affected by the oscillator failed condition.

If the voltage on the backup supply (either  $V_{\text{RTCcap}}$  or  $V_{\text{RTCbatt}}$ ) falls below their respective minimum level the oscillator may fail, leading to the oscillator failed condition which can be detected when system power is restored.

The value of OSCF should be reset to 0 when the time registers are written for the first time. This will initialize the state of this bit which may have become set when the system was first powered on.

### CALIBRATING THE CLOCK

The RTC is driven by a quartz controlled oscillator with a nominal frequency of 32.768 KHz. Clock accuracy will depend on the quality of the crystal, usually specified to 35 ppm limits at 25°C. This error could equate to  $\pm 1.53$  minutes per month. The STK17T88 employs a calibration circuit that can improve the accuracy to +1/-2 ppm at 25°C. The

calibration circuit adds or subtracts counts from the oscillator divider circuit.

The number of times pulses are suppressed (subtracted, negative calibration) or split (added, positive calibration) depends upon the value loaded into the five calibration bits found in calibration register at 0x7FF8. Adding counts speeds the clock up; subtracting counts slows the clock down. The Calibration bits occupy the five lower order bits in the control register 8. These bits can be set to represent any value between 0 and 31 in binary form. Bit D5 is a Sign bit, where a "1" indicates positive calibration and a "0" indicates negative calibration. Calibration occurs within a 64 minute cycle. The first 62 minutes in the cycle may, once per minute, have one second either shortened by 128 or lengthened by 256 oscillator cycles.

If a binary "1" is loaded into the register, only the first 2 minutes of the 64 minute cycle will be modified; if a binary 6 is loaded, the first 12 will be affected, and so on. Therefore each calibration step has the effect of adding 512 or subtracting 256 oscillator cycles for every 125,829,120 actual oscillator cycles. That is +4.068 or -2.034 ppm of adjustment per calibration step in the calibration register.

In order to determine how to set the calibration one may set the CAL bit in the flags register at 0x7FF0 to 1, which causes the INT pin to toggle at a nominal 512 Hz. Any deviation measured from the 512 Hz will indicate the degree and direction of the required correction. For example, a reading of 512.010124 Hz would indicate a +20 ppm error, requiring a -10 (001010) to be loaded into the Calibration register. Note that setting or changing the calibration register does not affect the frequency test output frequency.

### ALARM

The alarm function compares user-programmed values to the corresponding time-of-day values. When a match occurs, the alarm event occurs. The alarm drives an internal flag, AF, and may drive the INT pin if desired.

There are four alarm match fields. They are date, hours, minutes and seconds. Each of these fields also has a Match bit that is used to determine if the field is used in the alarm match logic. Setting the Match bit to "0" indicates that the corresponding field will be used in the match process.

Depending on the Match bits, the alarm can occur as specifically as one particular second on one day of the month, or as frequently as once per second



continuously. The MSB of each alarm register is a Match bit. Selecting none of the Match bits (all 1's) indicates that no match is required. The alarm occurs every second. Setting the match select bit for seconds to "0" causes the logic to match the seconds alarm value to the current time of day. Since a match will occur for only one value per minute, the alarm occurs once per minute. Likewise, setting the seconds and minutes Match bits causes an exact match of these values. Thus, an alarm will occur once per hour. Setting seconds, minutes and hours causes a match once per day. Lastly, selecting all match values causes an exact time and date match. Selecting other bit combinations will not produce meaningful results; however the alarm circuit should follow the functions described.

There are two ways a user can detect an alarm event, by reading the AF flag or monitoring the INT pin. The AF flag in the flags register at 0x7FF0 will indicate that a date/time match has occurred. The AF bit will be set to 1 when a match occurs. Reading the Flags/Control register clears the alarm flag bit (and all others). A hardware interrupt pin may also be used to detect an alarm event.

**WATCHDOG TIMER**

The watchdog timer is a free running down counter that uses the 32 Hz clock (31.25 ms) derived from the crystal oscillator. The oscillator must be running for the watchdog to function. It begins counting down from the value loaded in the Watchdog Timer register.

The counter consists of a loadable register and a free running counter. On power up, the watchdog time-out value in register 0x7FF7 is loaded into the counter load register. Counting begins on power up and restarts from the loadable value any time the Watchdog Strobe (WDS) bit is set to 1. The counter is compared to the terminal value of 0. If the counter reaches this value, it causes an internal flag and an optional interrupt output. The user can prevent the time-out interrupt by setting WDS bit to 1 prior to the counter reaching 0. This causes the counter to be reloaded with the watchdog time-out value and to be restarted. As long as the user sets the WDS bit prior to the counter reaching the terminal value, the interrupt and flag never occurs.

New time-out values can be written by setting the watchdog write bit to 0. When the  $\overline{WDW}$  is 0 (from the previous operation), new writes to the watchdog time-out value bits D<sub>5</sub>-D<sub>0</sub> allow the time-out value to be modified. When  $\overline{WDW}$  is a 1, then writes to bits D<sub>5</sub>-D<sub>0</sub> will be ignored. The  $\overline{WDW}$  function allows a user to

set the WDS bit without concern that the watchdog timer value will be modified. A logical diagram of the watchdog timer is shown below. Note that setting the watchdog time-out value to 0 would be otherwise meaningless and therefore disables the watchdog function.

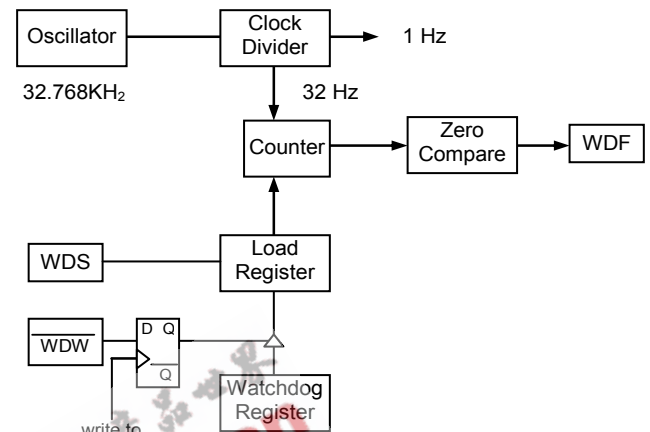

Figure 7. Watchdog Timer Block Diagram

The output of the watchdog timer is a flag bit WDF that is set if the watchdog is allowed to time-out. The flag is set upon a watchdog time-out and cleared when the Flags/Control register is read by the user. The user can also enable an optional interrupt source to drive the INT pin if the watchdog time-out occurs.

**POWER MONITOR**

The STK17T88 provides a power management scheme with power-fail interrupt capability. It also controls the internal switch to backup power for the clock and protects the memory from low-V<sub>CC</sub> access. The power monitor is based on an internal band-gap reference circuit that compares the V<sub>CC</sub> voltage to various thresholds.

As described in the *AutoStore*<sup>TM</sup> section previously, when V<sub>switch</sub> is reached as V<sub>CC</sub> decays from power loss, a data store operation is initiated from SRAM to the nonvolatile elements, securing the last SRAM data state. Power is also switched from V<sub>CC</sub> to the backup supply (battery or capacitor) to operate the RTC oscillator.

When operating from the backup source no data may be read or written and the clock functions are not available to the user. The clock continues to operate in the background. Updated clock data is available to

## STK17T88

the user after  $t_{HRECALL}$  delay (See *AutoStore™ /POWER-UP RECALL*) after  $V_{CC}$  has been restored to the device.

### INTERRUPTS

The STK17T88 provides three potential interrupt sources. They include the watchdog timer, the power monitor, and the clock/calendar alarm. Each can be individually enabled and assigned to drive the INT pin. In addition, each has an associated flag bit that the host processor can use to determine the cause of the interrupt.

Some of the sources have additional control bits that determine functional behavior. In addition, the pin driver has three bits that specify its behavior when an interrupt occurs. A functional diagram of the interrupt logic is shown below.

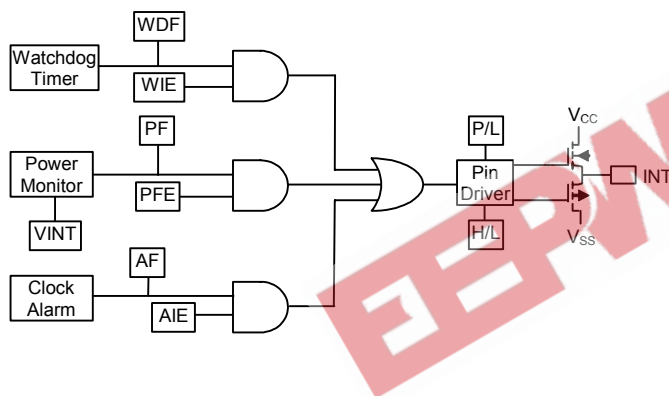

Figure 8. Interrupt Block Diagram

The three interrupts each have a source and an enable. Both the source and the enable must be active (true high) in order to generate an interrupt output. Only one source is necessary to drive the pin. The user can identify the source by reading the Flags/Control register, which contains the flags associated with each source. All flags are cleared to 0 when the register is read. The cycle must be a complete read cycle ( $\overline{WE}$  high); otherwise the flags will not be cleared. The power monitor has two programmable settings that are explained in the power monitor section.

Once an interrupt source is active, the pin driver determines the behavior of the output. It has two programmable settings as shown below. Pin driver control bits are located in the Interrupts register.

According to the programming selections, the pin can be driven in the backup mode for an alarm interrupt. In addition, the pin can be an active low (open-drain) or an active high (push-pull) driver. If programmed for operation during backup mode, it can only be active low. Lastly, the pin can provide a one-shot function so that the active condition is a pulse or a level condition. In one-shot mode, the pulse width is internally fixed at approximately 200 ms. This mode is intended to reset a host microcontroller. In level mode, the pin goes to its active polarity until the Flags/Control register is read by the user. This mode is intended to be used as an interrupt to a host microcontroller. The control bits are summarized as follows:

**Watchdog Interrupt Enable - WIE.** When set to 1, the watchdog timer drives the INT pin as well as an internal flag when a watchdog time-out occurs. When WIE is set to 0, the watchdog timer affects only the internal flag.

**Alarm Interrupt Enable - AIE.** When set to 1, the alarm match drives the INT pin as well as an internal flag. When set to 0, the alarm match only affects to internal flag.

**Power Fail Interrupt Enable - PFE.** When set to 1, the power fail monitor drives the pin as well as an internal flag. When set to 0, the power fail monitor affects only the internal flag.

**High/Low - H/L.** When set to a 1, the INT pin is active high and the driver mode is push-pull. The INT pin can drive high only when  $V_{CC} > V_{switch}$ . When set to a 0, the INT pin is active low and the drive mode is open-drain. Active low (open drain) is operational even in battery backup mode.

**Pulse/Level - P/L.** When set to a 1 and an interrupt occurs, the INT pin is driven for approximately 200 ms. When P/L is set to a 0, the INT pin is driven high or low (determined by H/L) until the Flags/Control register is read.

When an enabled interrupt source activates the INT pin, an external host can read the Flags/Control register to determine the cause. Remember that all flags will be cleared when the register is read. If the INT pin is programmed for Level mode, then the condition will clear and the INT pin will return to its inactive state. If the pin is programmed for Pulse mode, then reading the flag also will clear the flag and the pin. The pulse will not complete its specified duration if the Flags/Control register is read. If the INT pin is used as a host reset, then the Flags/Control register should not be read during a reset.

During a power-on reset with no battery, the interrupt register is automatically loaded with the value 24h. This causes power-fail interrupt to be enabled with an active-low pulse.

RTC Register Map

Register	BCD Format Data								Function / Range
	D7	D6	D5	D4	D3	D2	D1	D0	
0x7FFF	10s Years				Years				Years: 00-99
0x7FFE	0	0	0	10s Months	Months				Months: 01-12
0x7FFD	0	0	10s Day of Month		Day of Month				Day of Month: 01-31
0x7FFC	0	0	0	0	0	Day of Week			Day of week: 01-07
0x7FFB	0	0	10s Hours			Hours			Hours: 00-23
0x7FFA	0	10s Minutes			Minutes			Minutes: 00-59	
0x7FF9	10s Seconds			Seconds				Seconds: 00-59	
0x7FF8	$\overline{\text{OSCEN}}$	0	Cal Sign	Calibration				Calibration values*	
0x7FF7	WDS	$\overline{\text{WDW}}$	WDT				Watchdog*		
0x7FF6	WIE	AIE	PFE	ABE	$\overline{\text{H/L}}$	$\overline{\text{P/L}}$	0	0	Interrupts*
0x7FF5	$\overline{\text{M}}$	0	10s Alarm Date		Alarm Day				Alarm, Day of Month: 01-31
0x7FF4	$\overline{\text{M}}$	0	10s Alarm Hours		Alarm Hours				Alarm, hours: 00-23
0x7FF3	$\overline{\text{M}}$	10 Alarm Minutes			Alarm Minutes				Alarm, minutes: 00-59
0x7FF2	$\overline{\text{M}}$	10 Alarm Seconds			Alarm Seconds				Alarm, seconds: 00-59
0x7FF1	10s Centuries				Centuries				Centuries: 00-99
0x7FF0	WDF	AF	PF	OSCF	0	CAL	W	R	Flags*

\* - Is a binary value, not a BCD value.  
 0 - Not implemented, reserved for future use.

Register Map Detail

0x7FFF	Timekeeping – Years							
	D7	D6	D5	D4	D3	D2	D1	D0
	10s Years				Years			
	Contains the lower two BCD digits of the year. Lower nibble contains the value for years; upper nibble contains the value for 10s of years. Each nibble operates from 0 to 9. The range for the register is 0-99.							
0x7FFE	Timekeeping – Months							
	D7	D6	D5	D4	D3	D2	D1	D0
	0	0	0	10s Month	Months			
	Contains the BCD digits of the month. Lower nibble contains the lower digit and operates from 0 to 9; upper nibble (one bit) contains the upper digit and operates from 0 to 1. The range for the register is 1-12.							
0x7FFD	Timekeeping – Date							
	D7	D6	D5	D4	D3	D2	D1	D0
	0	0	10s Day of month		Day of month			
	Contains the BCD digits for the date of the month. Lower nibble contains the lower digit and operates from 0 to 9; upper nibble contains the upper digit and operates from 0 to 3. The range for the register is 1-31. Leap years are automatically adjusted for.							
0x7FFC	Timekeeping – Day							
	D7	D6	D5	D4	D3	D2	D1	D0
	0	0	0	0	0	Day of week		
	Lower nibble contains a value that correlates to day of the week. Day of the week is a ring counter that counts from 1 to 7 then returns to 1. The user must assign meaning to the day value, as the day is not integrated with the date.							
0x7FFB	Timekeeping – Hours							
	D7	D6	D5	D4	D3	D2	D1	D0
	12/24	0	10s Hours		Hours			
	Contains the BCD value of hours in 24 hour format. Lower nibble contains the lower digit and operates from 0 to 9; upper nibble (two bits) contains the upper digit and operates from 0 to 2. The range for the register is 0-23.							
0x7FFA	Timekeeping – Minutes							
	D7	D6	D5	D4	D3	D2	D1	D0
	0	10s Minutes			Minutes			
	Contains the BCD value of minutes. Lower nibble contains the lower digit and operates from 0 to 9; upper nibble contains the upper minutes digit and operates from 0 to 5. The range for the register is 0-59.							
0x7FF9	Timekeeping – Seconds							
	D7	D6	D5	D4	D3	D2	D1	D0
	0	10s Seconds			Seconds			
	Contains the BCD value of seconds. Lower nibble contains the lower digit and operates from 0 to 9; upper nibble contains the upper digit and operates from 0 to 5. The range for the register is 0-59.							

0x7FF8	Calibration / Control								
	D7	D6	D5	D4	D3	D2	D1	D0	
	OSCEN	0	Calibration Sign	Calibration					
OSCEN	Oscillator Enable. When set to 1, the oscillator is halted. When set to 0, the oscillator runs. Disabling the oscillator saves battery/capacitor power during storage. On a no-battery power-up, this bit is set to 0.								
Calibration Sign	Determines if the calibration adjustment is applied as an addition to or as a subtraction from the time-base.								
Calibration	These five bits control the calibration of the clock.								

0x7FF7	Watchdog Timer								
	D7	D6	D5	D4	D3	D2	D1	D0	
	WDS	WDW	WDT						
WDS	Watchdog Strobe. Setting this bit to 1 reloads and restarts the watchdog timer. Setting the bit to 0 has no affect. The bit is cleared automatically once the watchdog timer is reset. The WDS bit is write only. Reading it always will return a 0.								
WDW	Watchdog Write Enable. Setting this bit to 1 masks the watchdog time-out value (WDT5-WDT0) so it cannot be written. This allows the user to strobe the watchdog without disturbing the time-out value. Setting this bit to 0 allows bits 5-0 to be written on the next write to the Watchdog register. The new value will be loaded on the next internal watchdog clock after the write cycle is complete. This function is explained in more detail in the watchdog timer section.								
WDT	Watchdog time-out selection. The watchdog timer interval is selected by the 6-bit value in this register. It represents a multiplier of the 32 Hz count (31.25 ms). The minimum range or time-out value is 31.25 ms (a setting of 1) and the maximum time-out is 2 seconds (setting of 3Fh). Setting the watchdog timer register to 0 disables the timer. These bits can be written only if the WDW bit was cleared to 0 on a previous cycle.								

0x7FF6	Interrupt Status / Control							
	D7	D6	D5	D4	D3	D2	D1	D0
	WIE	AIE	PFIE	ABE	H/L	P/L	0	0
WIE	Watchdog Interrupt Enable. When set to 1 and a watchdog time-out occurs, the watchdog timer drives the INT pin as well as the WDF flag. When set to 0, the watchdog time-out affects only the WDF flag.							
AIE	Alarm Interrupt Enable. When set to 1, the alarm match drives the INT pin as well as the AF flag. When set to 0, the alarm match only affects the AF flag.							
PFIE	Power-Fail Enable. When set to 1, the alarm match drives the INT pin as well as the AF flag. When set to 0, the power-fail monitor affects only the PF flag.							
ABE	Alarm Battery-backup Enable. When set to 1, the alarm interrupt (as controlled by AIE) will function even in battery backup mode. When set to 0, the alarm will occur only when $V_{cc} > V_{switch}$ .							
H/L	High/Low. When set to a 1, the INT pin is driven active high. When set to 0, the INT pin is open drain, active low.							
P/L	Pulse/Level. When set to a 1, the INT pin is driven active (determined by H/L ) by an interrupt source for approximately 200 ms. When set to a 0, the INT pin is driven to an active level (as set by H/L ) until the Flags/Control register is read.							

0x7FF5	Alarm – Day							
	D7	D6	D5	D4	D3	D2	D1	D0
	$\overline{M}$	0	10s Alarm Date		Alarm Date			
	Contains the alarm value for the date of the month and the mask bit to select or deselect the date value.							
$\overline{M}$	Match. Setting this bit to 0 causes the date value to be used in the alarm match. Setting this bit to 1 causes the match circuit to ignore the date value.							
0x7FF4	Alarm – Hours							
	D7	D6	D5	D4	D3	D2	D1	D0
	$\overline{M}$	0	10s Alarm Hours		Alarm Hours			
	Contains the alarm value for the hours and the mask bit to select or deselect the hours value.							
$\overline{M}$	Match. Setting this bit to 0 causes the hours value to be used in the alarm match. Setting this bit to 1 causes the match circuit to ignore the hours value.							
0x7FF3	Alarm – Minutes							
	D7	D6	D5	D4	D3	D2	D1	D0
	$\overline{M}$	10s Alarm Minutes			Alarm Minutes			
	Contains the alarm value for the minutes and the mask bit to select or deselect the minutes value.							
$\overline{M}$	Match. Setting this bit to 0 causes the minutes value to be used in the alarm match. Setting this bit to 1 causes the match circuit to ignore the minutes value.							
0x7FF2	Alarm – Seconds							
	D7	D6	D5	D4	D3	D2	D1	D0
	$\overline{M}$	10s Alarm Seconds			Alarm Seconds			
	Contains the alarm value for the seconds and the mask bit to select or deselect the seconds' value.							
$\overline{M}$	Match. Setting this bit to 0 causes the seconds' value to be used in the alarm match. Setting this bit to 1 causes the match circuit to ignore the seconds value.							
0x7FF1	Timekeeping – Centuries							
	D7	D6	D5	D4	D3	D2	D1	D0
	0	0	10s Centuries		Centuries			

0x7FF0	Flags							
	D7	D6	D5	D4	D3	D2	D1	D0
	WDF	AF	PF	OSCF	0	CAL	W	R
WDF	Watchdog Timer Flag. This read-only bit is set to 1 when the watchdog timer is allowed to reach 0 without being reset by the user. It is cleared to 0 when the Flags/Control register is read.							
AF	Alarm Flag. This read-only bit is set to 1 when the time and date match the values stored in the alarm registers with the match bits = 0. It is cleared when the Flags/Control register is read.							
PF	Power-fail Flag. This read-only bit is set to 1 when power falls below the power-fail threshold $V_{switch}$ . It is cleared to 0 when the Flags/Control register is read.							
OSCF	Oscillator Fail Flag. Set to 1 on power-up only if the oscillator is not running in the first 5ms of power-on operation. This indicates that time counts are no longer valid. The user must reset this bit to 0 to clear this condition. The chip will not clear this flag. This bit survives power cycles.							
CAL	Calibration Mode. When set to 1, a 512Hz square wave is output on the INT pin. When set to 0, the INT pin resumes normal operation. This bit defaults to 0 (disabled) on power up.							
W	Write Time. Setting the W bit to 1 freeze updates of the timekeeping registers. The user can then write them with updated values. Setting the W bit to 0 causes the contents of the time registers to be transferred to the timekeeping counters.							
R	Read Time. Setting the R bit to 1 copies a static image of the timekeeping registers and places them in a holding register. The user can then read them without concerns over changing values causing system errors. The R bit going from 0 to 1 causes the timekeeping capture, so the bit must be returned to 0 prior to reading again.							

EEPW.com.cn  
电子產品世界

### ORDERING INFORMATION

STK17T88 - R F 45 I

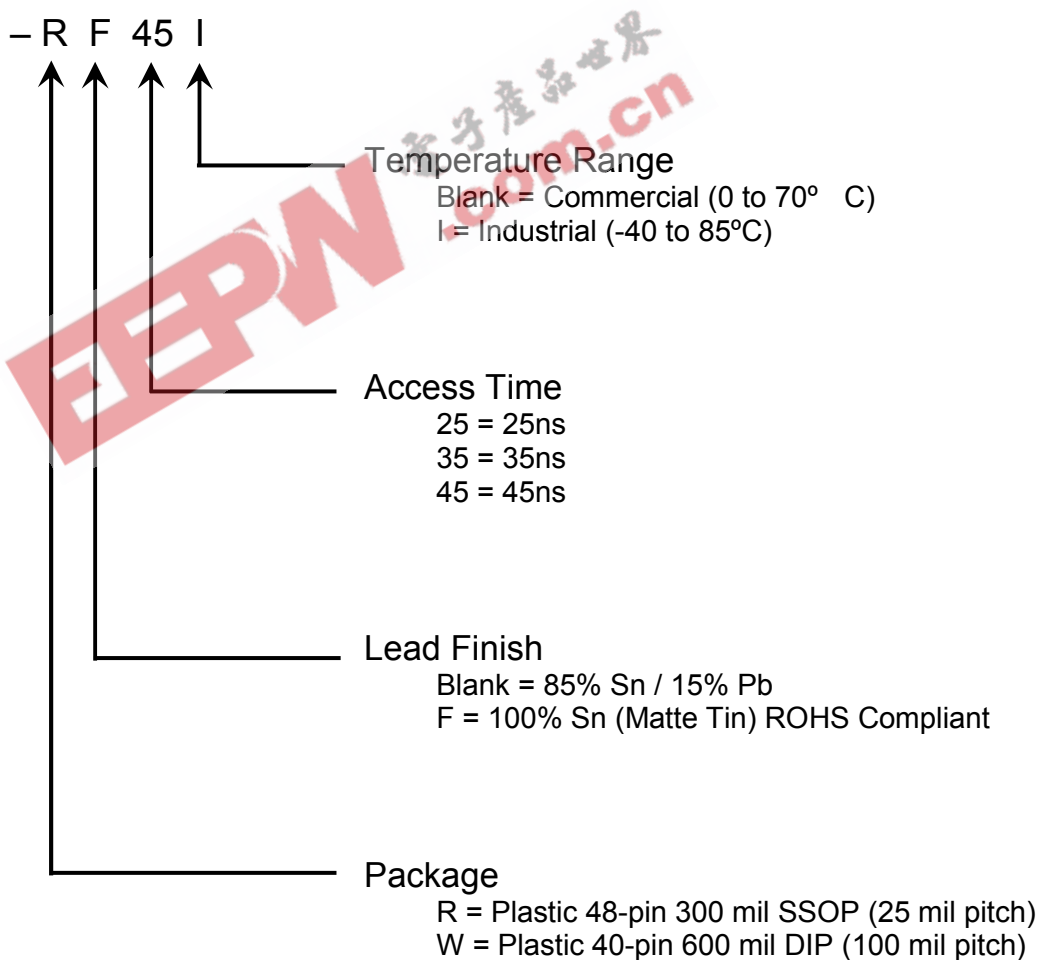



**Document Revision History**

Revision	Date	Summary																																																												
0.0	February 2003	Publish new datasheet																																																												
0.1	March 2003	Remove 525 mil SOIC, Add 48 Pin SSOP and 40 Pin DIP packages; Modified Block Diagram in <i>AutoStore</i> description section																																																												
1.0	December 2004	<table border="1"> <thead> <tr> <th>Parameter</th> <th>Old Value</th> <th>New Value</th> <th>Notes</th> </tr> </thead> <tbody> <tr> <td>Vcap Min</td> <td>10<math>\mu</math>F</td> <td>17 <math>\mu</math>F</td> <td></td> </tr> <tr> <td>t<sub>VCCRISE</sub></td> <td>NA</td> <td>150 <math>\mu</math>s</td> <td>New Spec</td> </tr> <tr> <td>I<sub>CC1</sub> Max Com.</td> <td>35 mA</td> <td>50 mA</td> <td>@ 45ns access</td> </tr> <tr> <td>I<sub>CC1</sub> Max Com.</td> <td>40 mA</td> <td>55 mA</td> <td>@ 35ns access</td> </tr> <tr> <td>I<sub>CC1</sub> Max Com.</td> <td>50 mA</td> <td>65 mA</td> <td>@ 25ns access</td> </tr> <tr> <td>I<sub>CC1</sub> Max Ind.</td> <td>35 mA</td> <td>55 mA</td> <td>@ 45ns access</td> </tr> <tr> <td>I<sub>CC1</sub> Max Ind.</td> <td>45 mA</td> <td>60 mA</td> <td>@ 35ns access</td> </tr> <tr> <td>I<sub>CC1</sub> Max Ind.</td> <td>55 mA</td> <td>70 mA</td> <td>@ 25ns access</td> </tr> <tr> <td>I<sub>CC2</sub> Max</td> <td>1.5 mA</td> <td>3.0 mA</td> <td>Com. &amp; Ind.</td> </tr> <tr> <td>I<sub>CC4</sub> Max</td> <td>0.5 mA</td> <td>3 mA</td> <td>Com &amp; Ind.</td> </tr> <tr> <td>t<sub>HRECALL</sub></td> <td>5 ms</td> <td>20 ms</td> <td></td> </tr> <tr> <td>t<sub>STORE</sub></td> <td>10 ms</td> <td>12.5 ms</td> <td></td> </tr> <tr> <td>t<sub>RECALL</sub></td> <td>20 <math>\mu</math>s</td> <td>40 <math>\mu</math>s</td> <td></td> </tr> <tr> <td>t<sub>GLQV</sub></td> <td>10 ns</td> <td>12 ns</td> <td>@ 25ns access</td> </tr> </tbody> </table>	Parameter	Old Value	New Value	Notes	Vcap Min	10 $\mu$ F	17 $\mu$ F		t <sub>VCCRISE</sub>	NA	150 $\mu$ s	New Spec	I <sub>CC1</sub> Max Com.	35 mA	50 mA	@ 45ns access	I <sub>CC1</sub> Max Com.	40 mA	55 mA	@ 35ns access	I <sub>CC1</sub> Max Com.	50 mA	65 mA	@ 25ns access	I <sub>CC1</sub> Max Ind.	35 mA	55 mA	@ 45ns access	I <sub>CC1</sub> Max Ind.	45 mA	60 mA	@ 35ns access	I <sub>CC1</sub> Max Ind.	55 mA	70 mA	@ 25ns access	I <sub>CC2</sub> Max	1.5 mA	3.0 mA	Com. & Ind.	I <sub>CC4</sub> Max	0.5 mA	3 mA	Com & Ind.	t <sub>HRECALL</sub>	5 ms	20 ms		t <sub>STORE</sub>	10 ms	12.5 ms		t <sub>RECALL</sub>	20 $\mu$ s	40 $\mu$ s		t <sub>GLQV</sub>	10 ns	12 ns	@ 25ns access
		Parameter	Old Value	New Value	Notes																																																									
		Vcap Min	10 $\mu$ F	17 $\mu$ F																																																										
		t <sub>VCCRISE</sub>	NA	150 $\mu$ s	New Spec																																																									
		I <sub>CC1</sub> Max Com.	35 mA	50 mA	@ 45ns access																																																									
		I <sub>CC1</sub> Max Com.	40 mA	55 mA	@ 35ns access																																																									
		I <sub>CC1</sub> Max Com.	50 mA	65 mA	@ 25ns access																																																									
		I <sub>CC1</sub> Max Ind.	35 mA	55 mA	@ 45ns access																																																									
		I <sub>CC1</sub> Max Ind.	45 mA	60 mA	@ 35ns access																																																									
		I <sub>CC1</sub> Max Ind.	55 mA	70 mA	@ 25ns access																																																									
		I <sub>CC2</sub> Max	1.5 mA	3.0 mA	Com. & Ind.																																																									
		I <sub>CC4</sub> Max	0.5 mA	3 mA	Com & Ind.																																																									
		t <sub>HRECALL</sub>	5 ms	20 ms																																																										
		t <sub>STORE</sub>	10 ms	12.5 ms																																																										
		t <sub>RECALL</sub>	20 $\mu$ s	40 $\mu$ s																																																										
t <sub>GLQV</sub>	10 ns	12 ns	@ 25ns access																																																											
1.1	January 2005	Changed "N" package reference to "R" package.																																																												
1.2	April 2005	Changed RTC register unused bits "X" to require zero "0" value when writing values.																																																												

SIMTEK STK17T88 Data Sheet, April 2005

Copyright 2005, Simtek Corporation. All rights reserved.

This datasheet may only be printed for the express use of Simtek Customers. No part of this datasheet may be reproduced in any other form or means without express written permission from Simtek Corporation. The information contained in this publication is believed to be accurate, but changes may be made without notice. Simtek does not assume responsibility for, or grant or imply any warranty, including MERCHANTABILITY or FITNESS FOR A PARTICULAR PURPOSE regarding this information, the product or its use. Nothing herein constitutes a license, grant or transfer of any rights to any Simtek patent, copyright, trademark or other proprietary right.