



ST92163

8/16-BIT FULL SPEED USB MCU FOR COMPOSITE DEVICES WITH 16 ENDPOINTS, 20K ROM, 2K RAM, I²C, SCI, & MFT

PRELIMINARY DATA

- Internal Memories: 20 Kbytes ROM/EPROM/OTP, 2 Kbytes RAM
- Register oriented 8/16 bit core
- 224 general purpose registers available as RAM, accumulators or index pointers
- Minimum instruction cycle time: 167 ns (@24 MHz CPU frequency)
- Low power modes: WFI, SLOW, HALT and STOP
- DMA controller for reduced processor overhead
- Full speed USB interface with DMA, compliant with USB specifications version 1.1 (in normal voltage mode)
- USB Embedded Functions with 16 fully configurable endpoints (buffer size programmable), supporting all USB data transfer types (Isochronous included)
- On-chip USB transceiver and 3.3 voltage regulator
- Multimaster I²C-bus serial interface up to 400KHz. with DMA capability
- Serial Communications Interface (SCI) with DMA capability:
 - Asynchronous mode up to 315 Kb/s
 - Synchronous mode up to 3 MHz
- External memory interface (8-bit data/16-bit address) with DMA capability from the USB
- 16-bit Multi-Function Timer (12 operating modes) with DMA capability
- 16-bit Timer with 8-bit prescaler and Watchdog
- 6-channel, 8-bit A/D Converter (ADC)
- 15 interrupt pins on 8 interrupt channels
- 14 pins programmable as wake-up or additional external interrupts
- 42 (DIP56) or 44 (QFP64) fully programmable I/Os with 6 or 8 high sink pads (10 mA @ 1 V)
- Programmable PLL clock generator (RCCU) using a low frequency external quartz (8 MHz)
- On-chip RC oscillator for low power operation

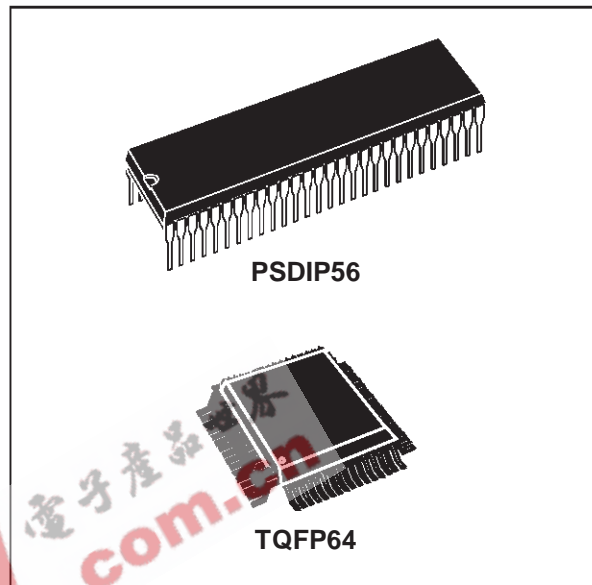

- Low Voltage Detector Reset on some devices¹
- Rich instruction set with 14 addressing modes
- Several operating voltage modes available on some devices¹:
 - Normal Voltage Mode
 - 8-MHz Low Voltage Mode
 - 16-MHz Low Voltage Mode
- 0 - 24 MHz CPU clock operation @ 4.0-5.5 V (all devices)
- 0 - 8 MHz CPU clock operation @ 3.0-4.0 V (8-MHz and 16-MHz Low Voltage devices)
- 0 - 16 MHz CPU clock operation @ 3.0-4.0 V (16-MHz Low Voltage devices only)
- Division-by-zero trap generation
- 0 °C to 70 °C temperature range
- Low EMI design supporting single sided PCB
- Complete development tools, including assembler, linker, C-compiler, archiver, source level debugger and hardware emulators, and Real Time Operating System

Note 1: Refer to "Device Summary" on page 6

Rev. 1.9

January 2000

1/224

This is preliminary information on a new product in development or undergoing evaluation. Details are subject to change without notice.

Table of Contents

ST92163	1
1 GENERAL DESCRIPTION	6
1.1 INTRODUCTION	6
1.1.1 Core Architecture	9
1.1.2 Instruction Set	9
1.1.3 External MEMORY INTERFACE	9
1.1.4 OPERATING MODES	9
1.1.5 On-chip Peripherals	10
1.2 PIN DESCRIPTION	11
1.3 I/O PORT PINS	13
1.4 MEMORY MAP	19
1.5 ST92163 REGISTER MAP	20
2 DEVICE ARCHITECTURE	27
2.1 CORE ARCHITECTURE	27
2.2 MEMORY SPACES	27
2.2.1 Register File	27
2.2.2 Register Addressing	29
2.3 SYSTEM REGISTERS	30
2.3.1 Central Interrupt Control Register	30
2.3.2 Flag Register	31
2.3.3 Register Pointing Techniques	32
2.3.4 Paged Registers	35
2.3.5 Mode Register	35
2.3.6 Stack Pointers	36
2.4 MEMORY ORGANIZATION	38
2.5 MEMORY MANAGEMENT UNIT	39
2.6 ADDRESS SPACE EXTENSION	40
2.6.1 Addressing 16-Kbyte Pages	40
2.6.2 Addressing 64-Kbyte Segments	41
2.7 MMU REGISTERS	41
2.7.1 DPR[3:0]: Data Page Registers	41
2.7.2 CSR: Code Segment Register	43
2.7.3 ISR: Interrupt Segment Register	43
2.7.4 DMASR: DMA Segment Register	43
2.8 MMU USAGE	45
2.8.1 Normal Program Execution	45
2.8.2 Interrupts	45
2.8.3 DMA	45
3 INTERRUPTS	46
3.1 INTRODUCTION	46
3.2 INTERRUPT VECTORING	47
3.2.1 Divide by Zero trap	47
3.2.2 Segment Paging During Interrupt Routines	48
3.3 INTERRUPT PRIORITY LEVELS	48

Table of Contents

3.4	PRIORITY LEVEL ARBITRATION	48
3.4.1	Priority level 7 (Lowest)	48
3.4.2	Maximum depth of nesting	48
3.4.3	Simultaneous Interrupts	48
3.4.4	Dynamic Priority Level Modification	49
3.5	ARBITRATION MODES	49
3.5.1	Concurrent Mode	49
3.5.2	Nested Mode	52
3.6	EXTERNAL INTERRUPTS	54
3.7	MANAGEMENT OF WAKE-UP LINES AND EXTERNAL INTERRUPT LINES	56
3.8	TOP LEVEL INTERRUPT	57
3.9	ON-CHIP PERIPHERAL INTERRUPTS	57
3.10	INTERRUPT RESPONSE TIME	58
3.11	INTERRUPT REGISTERS	59
3.12	WAKE-UP / INTERRUPT LINES MANAGEMENT UNIT (WUIMU)	63
3.12.1	Introduction	63
3.12.2	Main Features	63
3.12.3	Functional Description	64
3.12.4	Programming Considerations	66
3.12.5	Register Description	67
4	ON-CHIP DIRECT MEMORY ACCESS (DMA)	70
4.1	INTRODUCTION	70
4.2	DMA PRIORITY LEVELS	70
4.3	DMA TRANSACTIONS	71
4.4	DMA CYCLE TIME	73
4.5	SWAP MODE	73
4.6	DMA REGISTERS	74
5	RESET AND CLOCK CONTROL UNIT (RCCU)	75
5.1	INTRODUCTION	75
5.2	CLOCK CONTROL UNIT	75
5.2.1	Clock Control Unit Overview	75
5.3	CLOCK MANAGEMENT	77
5.3.1	PLL Clock Multiplier Programming	78
5.3.2	CPU Clock Prescaling	78
5.3.3	Peripheral Clock	78
5.3.4	Low Power Modes	79
5.3.5	Interrupt Generation	79
5.4	CLOCK CONTROL REGISTERS	81
5.5	OSCILLATOR CHARACTERISTICS	85
5.6	RESET/STOP MANAGER	86
5.6.1	Reset Pin Timing	87
5.7	STOP MODE	87
5.8	LOW VOLTAGE DETECTOR (LVD) RESET	88

Table of Contents

6 EXTERNAL MEMORY INTERFACE (EXTMI)	89
6.1 INTRODUCTION	89
6.2 EXTERNAL MEMORY SIGNALS	90
6.2.1 AS: Address Strobe	90
6.2.2 DS: Data Strobe	90
6.2.3 DS2: Data Strobe 2	90
6.2.4 RW: Read/Write	93
6.2.5 BREQ, BACK: Bus Request, Bus Acknowledge	93
6.2.6 PORT 0	94
6.2.7 PORT 1	94
6.2.8 WAIT: External Memory Wait	94
6.3 REGISTER DESCRIPTION	95
7 I/O PORTS	98
7.1 INTRODUCTION	98
7.2 SPECIFIC PORT CONFIGURATIONS	98
7.3 PORT CONTROL REGISTERS	98
7.4 INPUT/OUTPUT BIT CONFIGURATION	99
7.5 ALTERNATE FUNCTION ARCHITECTURE	103
7.5.1 Pin Declared as I/O	103
7.5.2 Pin Declared as an Alternate Input	103
7.5.3 Pin Declared as an Alternate Function Output	103
7.6 I/O STATUS AFTER WFI, HALT AND RESET	103
8 ON-CHIP PERIPHERALS	104
8.1 TIMER/WATCHDOG (WDT)	104
8.1.1 Introduction	104
8.1.2 Functional Description	105
8.1.3 Watchdog Timer Operation	106
8.1.4 WDT Interrupts	108
8.1.5 Register Description	109
8.2 MULTIFUNCTION TIMER (MFT)	111
8.2.1 Introduction	111
8.2.2 Functional Description	113
8.2.3 Input Pin Assignment	116
8.2.4 Output Pin Assignment	120
8.2.5 Interrupt and DMA	122
8.2.6 Register Description	124
8.3 USB PERIPHERAL (USB)	135
8.3.1 Introduction	135
8.3.2 Main Features	135
8.3.3 Functional Description	135
8.3.4 Register Description	138
8.3.5 Register pages summary	148
8.4 SERIAL COMMUNICATIONS INTERFACE (SCI)	150
8.4.1 Introduction	150
8.4.2 Functional Description	151
8.4.3 SCI Operating Modes	152

Table of Contents

8.4.4	Serial Frame Format	155
8.4.5	Clocks And Serial Transmission Rates	158
8.4.6	SCI Initialization Procedure	158
8.4.7	Input Signals	160
8.4.8	Output Signals	160
8.4.9	Interrupts and DMA	161
8.4.10	Register Description	164
8.5	I2C BUS INTERFACE	175
8.5.1	Introduction	175
8.5.2	Main Features	175
8.5.3	Functional Description	176
8.5.4	I2C State Machine	178
8.5.5	Interrupt Features	183
8.5.6	DMA Features	184
8.5.7	Register Description	186
8.6	A/D CONVERTER (A/D)	197
8.6.1	Introduction	197
8.6.2	Main Features	197
8.6.3	General Description	197
8.6.4	Register Description	199
9	ELECTRICAL CHARACTERISTICS	201
10	GENERAL INFORMATION	218
10.1	EPROM/OTP PROGRAMMING	218
10.2	PACKAGE DESCRIPTION	219
10.3	ORDERING INFORMATION	221
10.4	TRANSFER OF CUSTOMER CODE	221

1 GENERAL DESCRIPTION

1.1 INTRODUCTION

The ST9216x family brings the enhanced ST9 register-based architecture to a new range of high-performance microcontrollers specifically designed for USB (Universal Serial Bus) applications. Their performance derives from the use of a flexible 256-register programming model for ultra-fast context switching and real-time event response. The intelligent on-chip peripherals offload the ST9 core from I/O and data management processing tasks allowing critical application tasks to get the maximum use of core resources. The ST9 MCU devices support low power consumption and low voltage operation for power-efficient and low-cost embedded systems. In the ST92163 family, four different types of device are available:

Normal Voltage Devices with LVD function

They operate in Normal Voltage Mode only (4.0-5.5V @ 24MHz) and include the Low Voltage Detector (LVD) function.

Normal Voltage Devices without LVD function

They operate in Normal Voltage Mode only (4.0-5.5V @ 24MHz) and do not include the Low Voltage Detector (LVD) function.

8-MHz Low Voltage Devices

They do not include the Low Voltage Detector (LVD) function and they support two operating voltage modes:

- Normal Voltage mode (4.0-5.5V @ 24MHz) with full functionality including USB.
- 8-MHz Low Voltage mode (3.0-4.0V @ 8MHz) without the USB interface.

16-MHz Low Voltage Devices

They do not include the Low Voltage Detector (LVD) function and they support three operating voltage modes:

- Normal Voltage mode (4.0-5.5V @ 24MHz) with full functionality including USB.
- 8-MHz Low Voltage mode (3.0-4.0V @ 8MHz) without the USB interface.
- 16-MHz Low Voltage mode (3.0-4.0V @ 16MHz) without the USB interface.

Figure 1, on page 7 shows the operating range of the ST92163 devices.

Device Summary

Device	Package	Program Memory	RAM	16-MHz Low Voltage Mode	8-MHz Low Voltage Mode	LVD	USB
ST92163 ¹	PSDIP56/	20K ROM	2K	No	No	Yes	Yes
ST92T163	TQFP64	20K OTP					
ST92E163	CSDIP56/	20K EPROM					
ST92163E ¹	PSDIP56/	20K ROM					
ST92T163E	TQFP64	20K OTP					
ST92E163E	CSDIP56/	20K EPROM					
ST92163L ¹	TQFP64	20K ROM		No	Yes	No	In Normal Mode only
ST92T163L		20K OTP					
ST92E163L	CQFP64	20K EPROM					
ST92163V ¹	TQFP64	20K ROM		Yes			
ST92T163V ¹		20K OTP					
ST92E163V ¹	CQFP64	20K EPROM					

¹ Contact sales office for availability

INTRODUCTION (Cont'd)

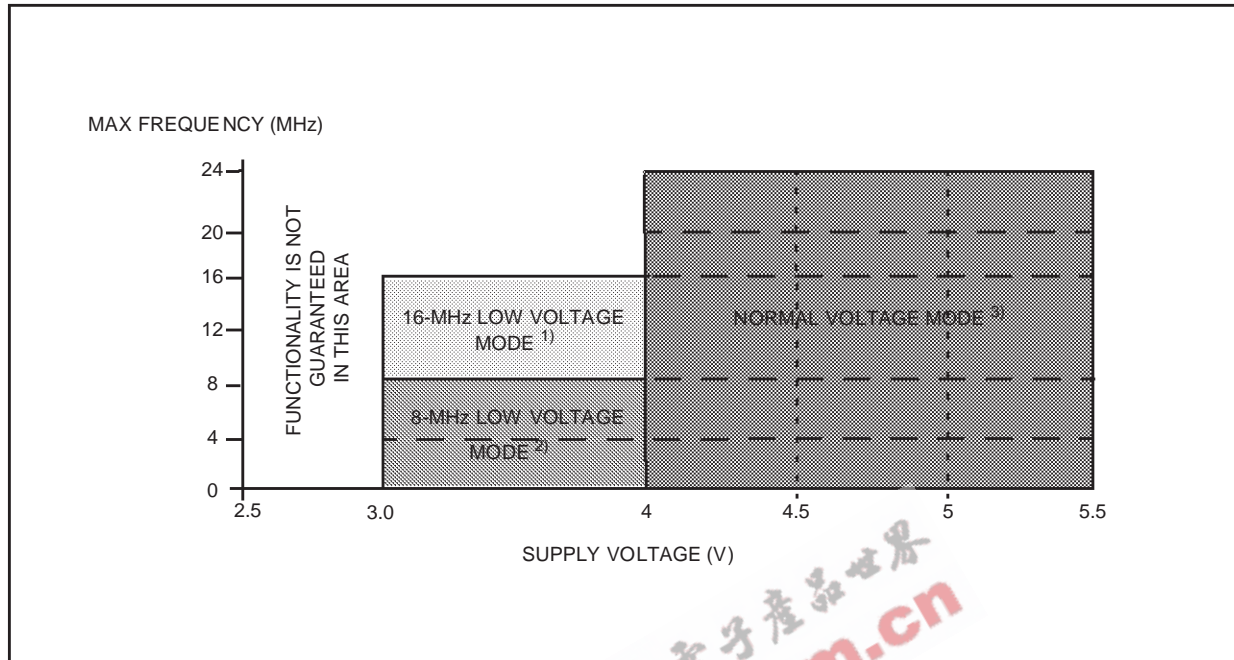
Figure 1. Maximum Operating Frequency (f_{MAX}) versus Supply Voltage (V_{DD})**Notes:**

- 1) This mode is supported by 16-MHz Low Voltage devices only
- 2) This mode is supported by 8-MHz Low Voltage devices and 16-MHz Low Voltage devices
- 3) This mode is supported by all devices

ST92163 - GENERAL DESCRIPTION

INTRODUCTION (Cont'd)

Figure 2. ST92163 Architectural Block Diagram

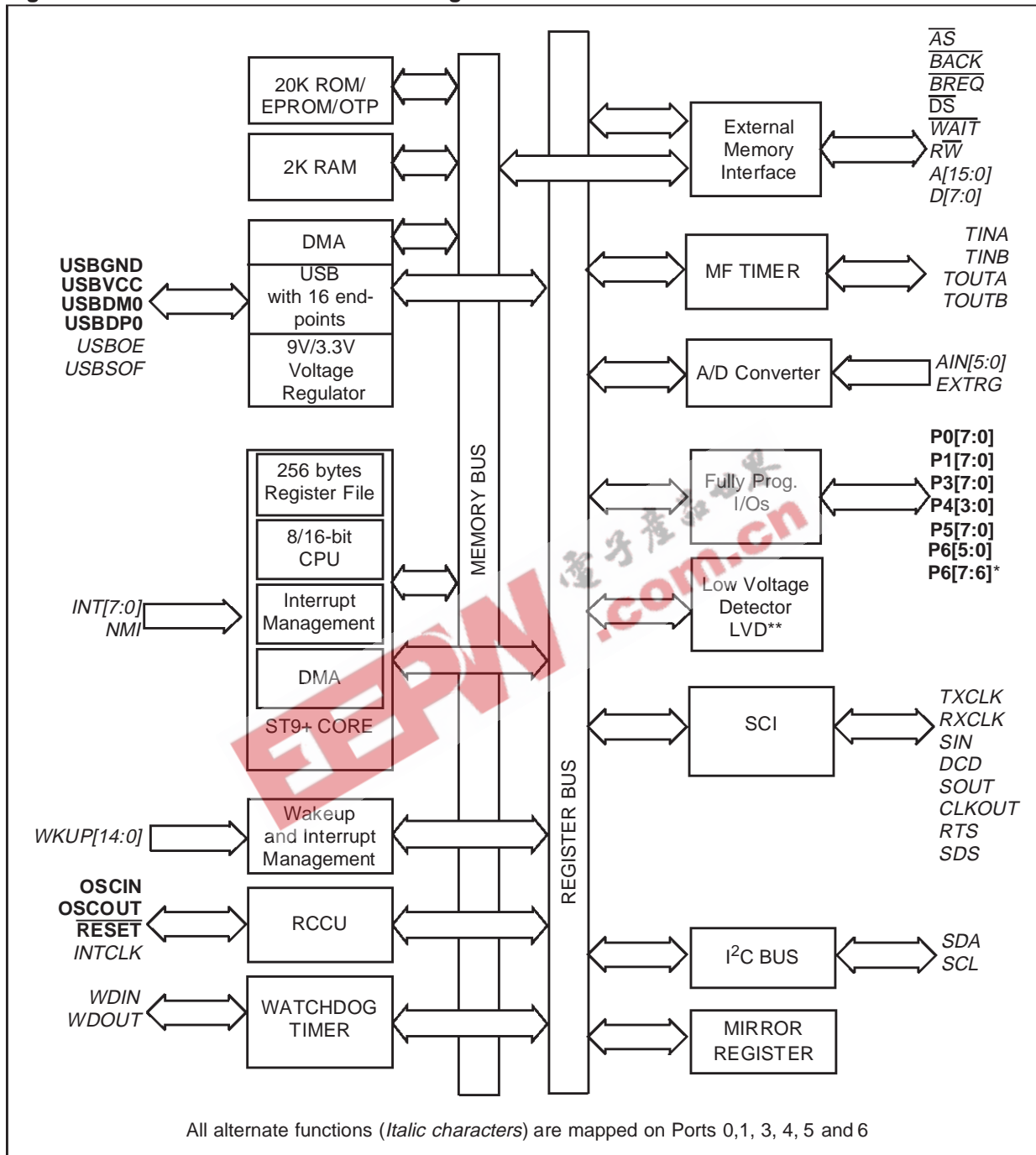

*64-pin devices only

**on some devices only (refer to "Device Summary" on page 6)

INTRODUCTION (Cont'd)

1.1.1 Core Architecture

The nucleus of the ST92163 is the enhanced ST9 Core that includes the Central Processing Unit (CPU), the register file, the interrupt and DMA controller, and the Memory Management Unit (MMU).

Three independent buses are controlled by the Core: a 22-bit memory bus, an 8-bit register addressing bus and a 6-bit interrupt/DMA bus which connects the interrupt and DMA controllers in the on-chip peripherals with the core.

This multiple bus architecture makes the ST9 family devices highly efficient for accessing on and off-chip memory and fast exchange of data with the on-chip peripherals.

The general-purpose registers can be used as accumulators, index registers, or address pointers. Adjacent register pairs make up 16-bit registers for addressing or 16-bit processing. Although the ST9 has an 8-bit ALU, the chip handles 16-bit operations, including arithmetic, loads/stores, and memory/register and memory/memory exchanges. Many opcodes specify byte or word operations, the hardware automatically handles 16-bit operations and accesses.

For interrupts or subroutine calls, the CPU uses a system stack in conjunction with the stack pointer (SP). A separate user stack has its own SP. The separate stacks, without size limitations, can be in on-chip RAM (or in Register File) or off-chip memory.

1.1.2 Instruction Set

The ST9 instruction set consists of 94 instruction types, including instructions for bit handling, byte (8-bit) and word (16-bit) data, as well as BCD and Boolean formats. Instructions have been added to facilitate large program and data handling through the MMU, as well as to improve the performance and code density of C Function calls. 14 addressing modes are available, including powerful indirect addressing capabilities.

The bit-manipulation instructions of the ST9 are set, clear, complement, test and set, load, and various logic instructions (AND, OR, and XOR). Math

functions include add, subtract, increment, decrement, decimal adjust, multiply and divide.

1.1.3 External MEMORY INTERFACE

The ST92163 device has a 16-bit external address bus allowing it to address up to 64K bytes of external memory.

1.1.4 OPERATING MODES

To optimize performance versus the power consumption of the device, ST9 devices now support a range of operating modes that can be dynamically selected depending on the performance and functionality requirements of the application at a given moment.

Run Mode. This is the full speed execution mode with CPU and peripherals running at the maximum clock speed delivered by the Phase Locked Loop (PLL) of the Clock Control Unit (CCU).

Slow Mode. Power consumption can be significantly reduced by running the CPU and the peripherals at reduced clock speed using the CPU Prescaler and CCU Clock Divider.

Wait For Interrupt Mode. The Wait For Interrupt (WFI) instruction suspends program execution until an interrupt request is acknowledged. During WFI, the CPU clock is halted while the peripheral and interrupt controller keep running at a frequency programmable via the CCU. In this mode, the power consumption of the device can be reduced by more than 95% (LP WFI).

Halt Mode. When executing the HALT instruction, and if the Watchdog is not enabled, the CPU and its peripherals stop operating and the status of the machine remains frozen (the clock is also stopped). A reset is necessary to exit from Halt mode.

Stop Mode. Under user program control, (see Wake-up and Interrupt Management Unit), the CPU and its peripherals stop operating and the status of the machine remains frozen (the clock is also stopped) until program execution is woken up by an event on an external Wake-up pin.

INTRODUCTION (Cont'd)

1.1.5 On-chip Peripherals

USB Interface

The USB interface provides a full speed USB 1.1 compliant port with embedded transceiver and voltage regulator. Up to 16 endpoints are available supporting up to 8 USB devices. Separate transmit and receive DMA channels are available for each device for fast data transfers with internal RAM.

Parallel I/O Ports

The ST9 is provided with dedicated lines for input/output. These lines, grouped into 8-bit ports, can be independently programmed to provide parallel input/output or to carry input/output signals to or from the on-chip peripherals and core. All ports have active pull-ups and pull-down resistors compatible with TTL loads. In addition pull-ups can be turned off for open drain operation and weak pull-ups can be turned on to save chip resistive pull-ups. Input buffers can be either TTL or CMOS compatible.

High Current (10 mA) outputs are available for driving external devices such as LEDs.

Multifunction Timer

The Multifunction Timer has a 16-bit Up/Down counter supported by two 16-bit compare registers, two 16-bit input capture registers and two DMA channels. Timing resolution can be programmed using an 8-bit prescaler. 12 operating modes allow a range of different timing functions to be easily performed such as complex waveform generation, measurement or PWM output.

16-bit Timer/Watchdog

The Timer/Watchdog peripheral can be used as a watchdog or for a wide range of other timing functions such as generating periodic interrupts, measuring input signal pulse widths, requesting an interrupt after a set number of events. It can also generate a square wave or PWM output signal.

Serial Communications Controller

The SCI provides a synchronous or asynchronous serial I/O port using two DMA channels. Baud rates and data formats are programmable. Controller applications can further benefit from the self test and address wake-up facility offered by the character search mode.

I²C Bus Interface

The I²C bus is a synchronous serial bus for connecting multiple devices using a data line and a clock line. Multimaster and slave modes are supported. Data transfer between the bus and memory is performed by DMA. The I²C interface supports 7 and 10-bit addressing. It operates in multimaster or slave mode and supports speeds of up to 400 KHz. Bus events (Bus busy, slave address recognized) and error conditions are automatically flagged in peripheral registers and interrupts are optionally generated.

Analog/Digital Converter

The ADC provides up to 6 analog inputs with on-chip sample and hold, fast conversion time and 8-bit resolution. Conversion can be triggered by a signal from the Multifunction Timer (MFT).

1.2 PIN DESCRIPTION

Figure 3. 64-Pin Package Pin-Out

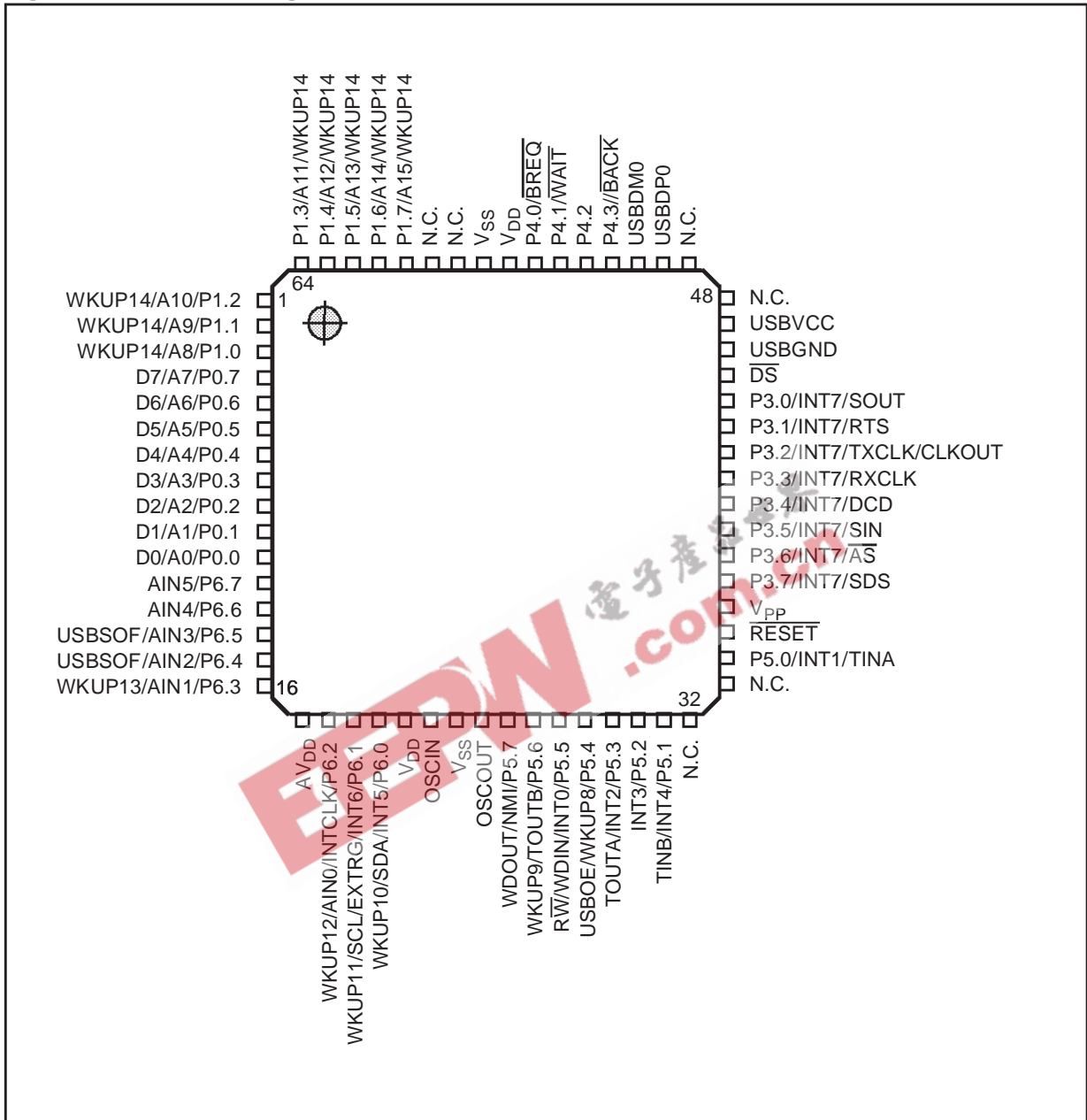

N.C. = Not connected

ST92163 - GENERAL DESCRIPTION

Figure 4. 56-Pin Package Pin-Out

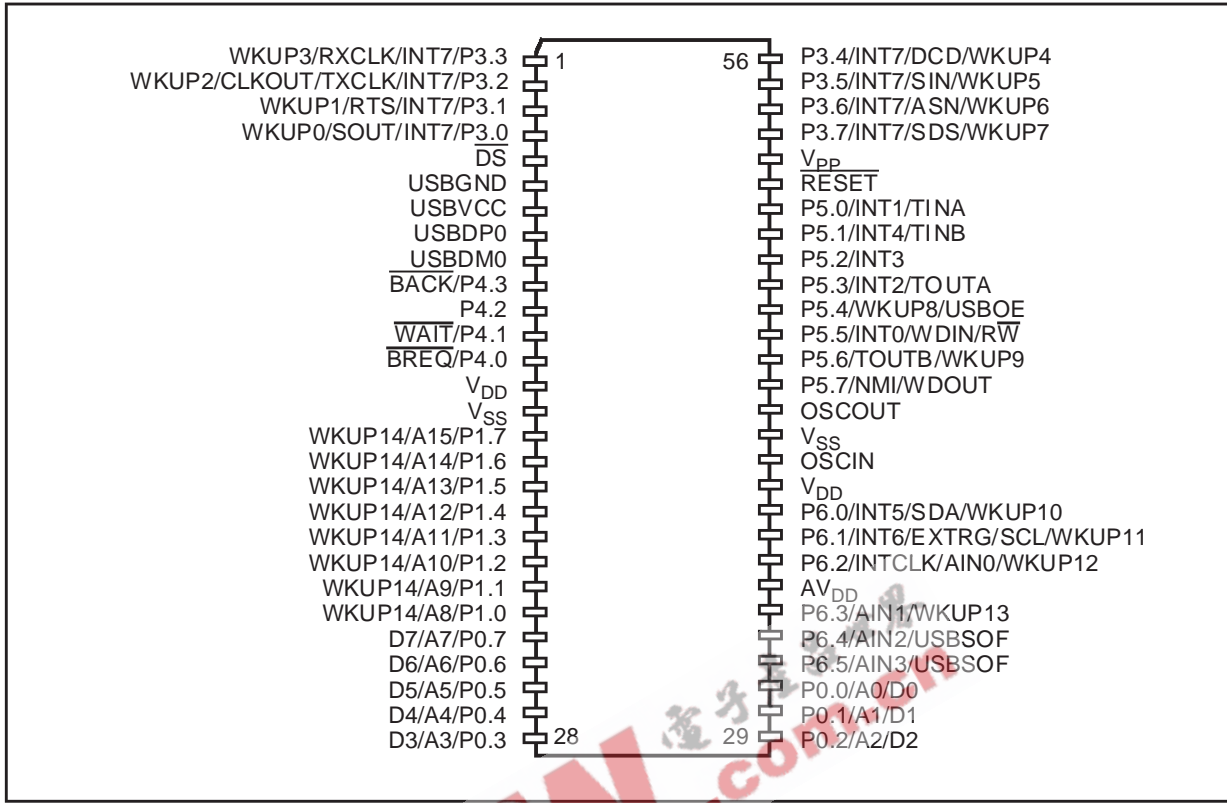

Table 1. Power Supply Pins

Name	Function	DIP56	QFP64
V _{DD}	Main Power Supply Voltage (2 pins internally connected)	14	21
		39	56
V _{SS}	Digital Circuit Ground (2 pins internally connected)	15	23
		41	57
AV _{DD}	Analog Circuit Supply Voltage	35	17
V _{PP}	EPROM Programming Voltage. Must be connected to ground in normal operating mode.	52	36

Table 2. Primary Function pins

Name	Function	DIP56	QFP64
DS	Data Strobe	5	45
OSCIN	Oscillator Input	40	22
OSCOUT	Oscillator Output	42	24
RESET	Reset to initialize the ST9	51	35
USBGND	USB bus ground level	6	46
USBVCC	USB voltage regulator output	7	47
USBDM0	USB Upstream port Data- line	9	51
USBDM0	USB Upstream port Data+ line	8	50

1.3 I/O Port Pins

All the ports of the device can be programmed as Input/Output or in Input mode, compatible with TTL or CMOS levels (except where Schmitt Trigger is present). Each bit can be programmed individually (Refer to the I/O ports chapter).

TTL/CMOS Input

For all those port bits where no input schmitt trigger is implemented, it is always possible to program the input level as TTL or CMOS compatible by programming the relevant PxC2.n control bit. Refer I/O Ports Chapter to the section titled "Input/Output Bit Configuration".

Push-Pull/OD Output

The output buffer can be programmed as push-pull or open-drain: attention must be paid to the fact that the open-drain option corresponds only to a disabling of P-channel MOS transistor of the buffer itself: it is still present and physically connected to the pin. Consequently it is not possible to increase the output voltage on the pin over $V_{DD}+0.3$ Volt, to avoid direct junction biasing.

Pure Open-drain Output

The user can increase the voltage on an I/O pin over $V_{DD}+0.3$ Volt where the P-channel MOS transistor is physically absent: this is allowed on all "Pure Open Drain" pins. Of course, in this case the push-pull option is not available and any weak pull-up must implemented externally.

Table 3. I/O Port Characteristics

	Input	Output	Weak Pull-Up	Reset State
Port 0[7:0]	TTL/CMOS	Push-Pull/OD	Yes	Bidirectional WPU
Port 1[7:0]	TTL/CMOS	Push-Pull/OD	Yes	Bidirectional WPU
Port 3[7:0]	Schmitt trigger	Push-Pull/OD	Yes	Bidirectional WPU
Port 4[3:0]	Schmitt trigger	Push-Pull/OD	Yes	Bidirectional WPU
Port 5[7:0]	Schmitt trigger	Push-Pull/OD	Yes	Bidirectional WPU
Port 6[1:0]	Schmitt trigger	Pure Open Drain with high sink capability	No	Bidirectional
Port 6[5:2]	TTL/CMOS	Push-Pull/OD with high sink capability	Yes	Bidirectional WPU
Port 6.6	Schmitt trigger	Push-Pull/OD with high sink capability	No	Bidirectional
Port 6.7	TTL/CMOS	Push-Pull/OD with high sink capability	No	Bidirectional

Legend: WPU = Weak Pull-Up, OD = Open Drain

ST92163 - GENERAL DESCRIPTION

Table 4. ST92163 Alternate Functions

Port Name	General Purpose I/O	Pin No.		Alternate Functions		
		DIP56	QFP64			
P0.0	All ports useable for general purpose I/O (input, output or bidirectional)	31	11	A0/D0	I/O	Ext. Mem. Address/Data bit 0
P0.1		30	10	A1/D1	I/O	Ext. Mem. Address/Data bit 1
P0.2		29	9	A2/D2	I/O	Ext. Mem. Address/Data bit 2
P0.3		28	8	A3/D3	I/O	Ext. Mem. Address/Data bit 3
P0.4		27	7	A4/D4	I/O	Ext. Mem. Address/Data bit 4
P0.5		26	6	A5/D5	I/O	Ext. Mem. Address/Data bit 5
P0.6		25	5	A6/D6	I/O	Ext. Mem. Address/Data bit 6
P0.7		24	4	A7/D7	I/O	Ext. Mem. Address/Data bit 7
P1.0		23	3	A8	I/O	Ext. Mem. Address bit 8
				WKUP14	I	Wakeup Line 14 (***)
P1.1		22	2	A9	I/O	Ext. Mem. Address bit 9
				WKUP14	I	Wakeup Line 14 (***)
P1.2		21	1	A10	I/O	Ext. Mem. Address bit 10
				WKUP14	I	Wakeup Line 14 (***)
P1.3		20	64	A11	I/O	Ext. Mem. Address bit 11
				WKUP14	I	Wakeup Line 14 (***)
P1.4		19	63	A12	I/O	Ext. Mem. Address bit 12
				WKUP14	I	Wakeup Line 14 (***)
P1.5		18	62	A13	I/O	Ext. Mem. Address bit 13
				WKUP14	I	Wakeup Line 14 (***)
P1.6		17	61	A14	I/O	Ext. Mem. Address bit 14
				WKUP14	I	Wakeup Line 14 (***)
P1.7		16	60	A15	I/O	Ext. Mem. Address bit 15
				WKUP14	I	Wakeup Line 14 (***)
P3.0	4	44	WKUP0	I	Wakeup Line 0	
			INT7	I	External Interrupt 7 (*)	
			SOUT	O	SCI Data Output	
P3.1	3	43	WKUP1	O	Wakeup Line 1	
			INT7	I	External Interrupt 7 (*)	
			RTS	O	SCI Request to Send	

Port Name	General Purpose I/O	Pin No.		Alternate Functions		
		DIP56	QFP64			
P3.2	All ports useable for general purpose I/O (input, output or bidirectional)	2	42	WKUP2	I	Wakeup Line 2
INT7				I	External Interrupt 7 (*)	
TXCLK				I	SCI Transmit CK Input	
CLKOUT				O	SCI Clock Output	
P3.3		1	41	WKUP3	I	Wakeup Line 3
INT7				I	External Interrupt 7 (*)	
RXCLK				I	SCI Receive CK Input	
				O		
P3.4		56	40	WKUP4	I	Wakeup Line 4
INT7				I	External Interrupt 7 (*)	
DCD				I	SCI Data Carrier Detect	
				O		
P3.5		55	39	WKUP5	I	Wakeup Line 5
INT7				I	External Interrupt 7 (*)	
SIN				I	SCI Data Input	
				O		
P3.6	54	38	WKUP6	I	Wakeup Line 6	
INT7			I	External Interrupt 7 (*)		
AS (**)			O	Ext. Mem. Address Strobe		
P3.7	53	37	WKUP7	I	Wakeup Line 7	
INT7			I	External Interrupt 7 (*)		
SDS			O	SCI Synchronous Data Send		
P4.0	13	55	BREQ	I	Ext. Mem. Bus Request	
P4.1	12	54	WAIT	I	Ext. Mem. Wait Input	
			RW	O	Ext. Mem. Read/Write Mode Select	
P4.2	11	53		I		
			AS (**)	O	Ext. Mem. Address Strobe	
P4.3	10	52		I		
			BACK	O	Ext. Mem. bus acknow	

ST92163 - GENERAL DESCRIPTION

Port Name	General Purpose I/O	Pin No.		Alternate Functions		
		DIP56	QFP64			
P5.0	All ports useable for general purpose I/O (input, output or bidirectional)	50	34	INT1	I	External Interrupt 1
				TINA	I	MF Timer Input A
					O	
P5.1		49	31	INT4	I	External Interrupt 4
				TINB	I	MF Timer Input B
					O	
P5.2		48	30	INT3	I	External Interrupt 3
P5.3		47	29	INT2	I	External Interrupt 2
				TOUTA	O	MF Timer Output A
P5.4		46	28	WKUP8	I	Wakeup Line 8
				USBOE	O	USB Output enable
P5.5		45	27	WDIN	I	Watchdog Timer Input
				INT0	I	External Interrupt 0
				R \bar{W}	O	Ext. Mem. Read/Write Mode Select
P5.6		44	26	WKUP9	I	Wakeup Line 9
	TOUTB			O	MF Timer Output B	
P5.7	43	25	NMI	I	Non Maskable Interrupt	
			WDOUT	O	Watchdog Timer Output	
P6.0	38	20	WKUP10	I	Wakeup Line 10	
			INT5	I	External Interrupt 5	
			SDAI	I	I ² C Bus Data In	
			SDAO	O	I ² C Bus Data Out	
P6.1	37	19	WKUP11	I	Wakeup Line 11	
			INT6	I	External Interrupt 6	
			SCLI	I	I ² C Bus Clock In	
			EXTRG	I	A/D External Trigger	
			SCLO	O	I ² C Bus Clock Out	
P6.2	36	18	AIN0	I	A/D Analog Input 0	
			WKUP12	I	Wakeup Line 12	
			INTCLK	O	Internal Clock	
P6.3	34	16	WKUP13	I	Wakeup Line 13	
			AIN1	I	A/D Analog Input 1	
				O		

Port Name	General Purpose I/O	Pin No.		Alternate Functions		
		DIP56	QFP64			
P6.4	All ports useable for general purpose I/O (input, output or bidirectional)	33	15	AIN2	I	A/D Analog Input 2
				USBSOF	O	USB SOF Synchro
P6.5		32	14	AIN3	I	A/D Analog Input 3
				USBSOF	O	USB SOF Synchro
P6.6		-	13	AIN4	I	A/D Analog Input 4
					O	
P6.7		-	12	AIN5	I	A/D Analog Input 5
					O	

*Eight interrupt lines internally connected to INT7 through a boolean AND function.

** \overline{AS} cannot be disabled by software if the ASAF bit is set (Page Register 245) once the corresponding P3.6 bit is configured as an Alternate Function output.

***Eight wakeup lines internally connected to WKUP14 through a boolean AND function.

Note: The reset state of Port 0 and Port 1 is Input, Weak Pull-Up. To interface external memory, the ports must be configured by software as alternate function output.

How to configure the I/O ports

To configure the I/O ports, use the information in Table 3 and Table 4 and the Port Bit Configuration Table in the I/O Ports Chapter on page 100.

I/O Note = the hardware characteristics fixed for each port line.

Inputs:

- If I/O note = TTL/CMOS, either TTL or CMOS input level can be selected by software.
- If I/O note = Schmitt trigger, selecting CMOS or TTL input by software has no effect, the input will always be Schmitt Trigger.

Outputs:

- If I/O note = Push-Pull, either Push Pull or Open Drain can be selected by software.
- If I/O note = Open Drain, selecting Push-Pull by software has no effect, the input will always be Open Drain.

Alternate Functions (AF) = More than one AF cannot be assigned to an external pin at the same time: it can be selected as follows, but simultaneous availability of several functions of one pin is obviously impossible.

AF Inputs:

- AF is selected implicitly by enabling the corresponding peripheral. Exceptions to this are ADC

inputs which are selected explicitly as AF by software.

AF Outputs or Bidirectional Lines:

- In the case of Outputs or I/Os, AF is selected explicitly by software.

Example 1: Timer/Watchdog input

AF: WDIN, Port: P5.5, I/O note: Input Schmitt Trigger.

Write the port configuration bits:

P5C2.5=1

P5C1.5=0

P5C0.5=1

Enable the WDT peripheral by software as described in the WDT chapter.

Example 2: Timer/Watchdog output

AF: WDOUT, Port: P5.7, I/O note: None

Write the port configuration bits:

P5C2.7=0

P5C1.7=1

P5C0.7=1

Example 3: ADC input

AF: AIN0, Port: P6.2, I/O note: Does not apply to ADC

Write the port configuration bits:

P6C2.2=1

P6C1.2=1

P6C0.2=1

1.4 MEMORY MAP

Figure 5. ST92163 Memory Map

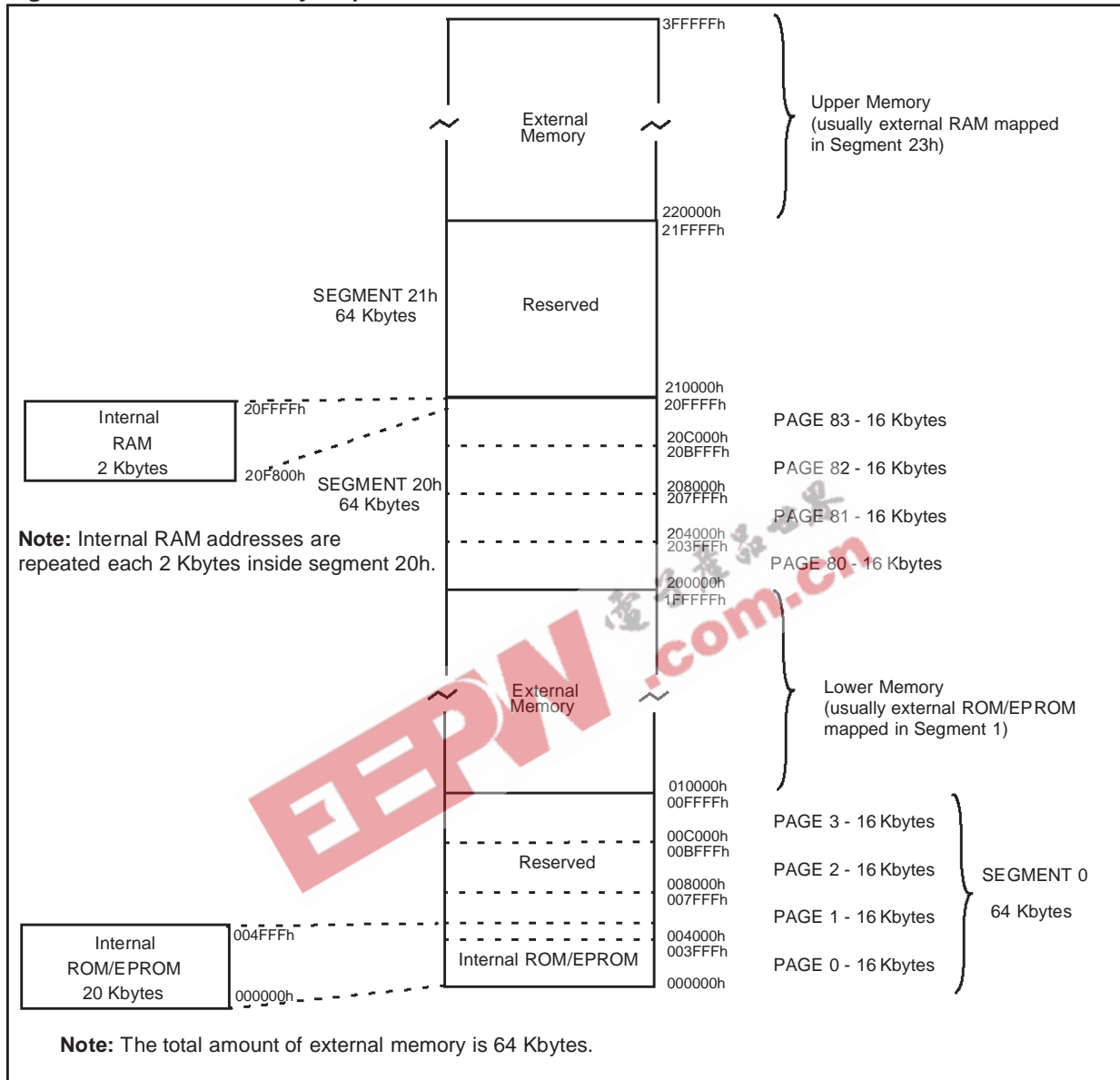

ST92163 - GENERAL DESCRIPTION

1.5 ST92163 REGISTER MAP

Table 6 contains the map of the group F peripheral pages.

The common registers used by each peripheral are listed in Table 5.

Be very careful to correctly program both:

- The set of registers dedicated to a particular function or peripheral.

– Registers common to other functions.

- In particular, double-check that any registers with “undefined” reset values have been correctly initialized.

Warning: Note that in the **EIVR** and each **IVR** register, all bits are significant. Take care when defining base vector addresses that entries in the Interrupt Vector table do not overlap.

Table 5. Common Registers

Function or Peripheral	Common Registers
SCI, MFT	CICR + NICR + DMA REGISTERS + I/O PORT REGISTERS
ADC	CICR + NICR + I/O PORT REGISTERS
WDT	CICR + NICR + EXTERNAL INTERRUPT REGISTERS + I/O PORT REGISTERS
I/O PORTS	I/O PORT REGISTERS + MODER
EXTERNAL INTERRUPT	INTERRUPT REGISTERS + I/O PORT REGISTERS
RCCU	INTERRUPT REGISTERS + MODER

Figure 6. ST92163 Register Groups

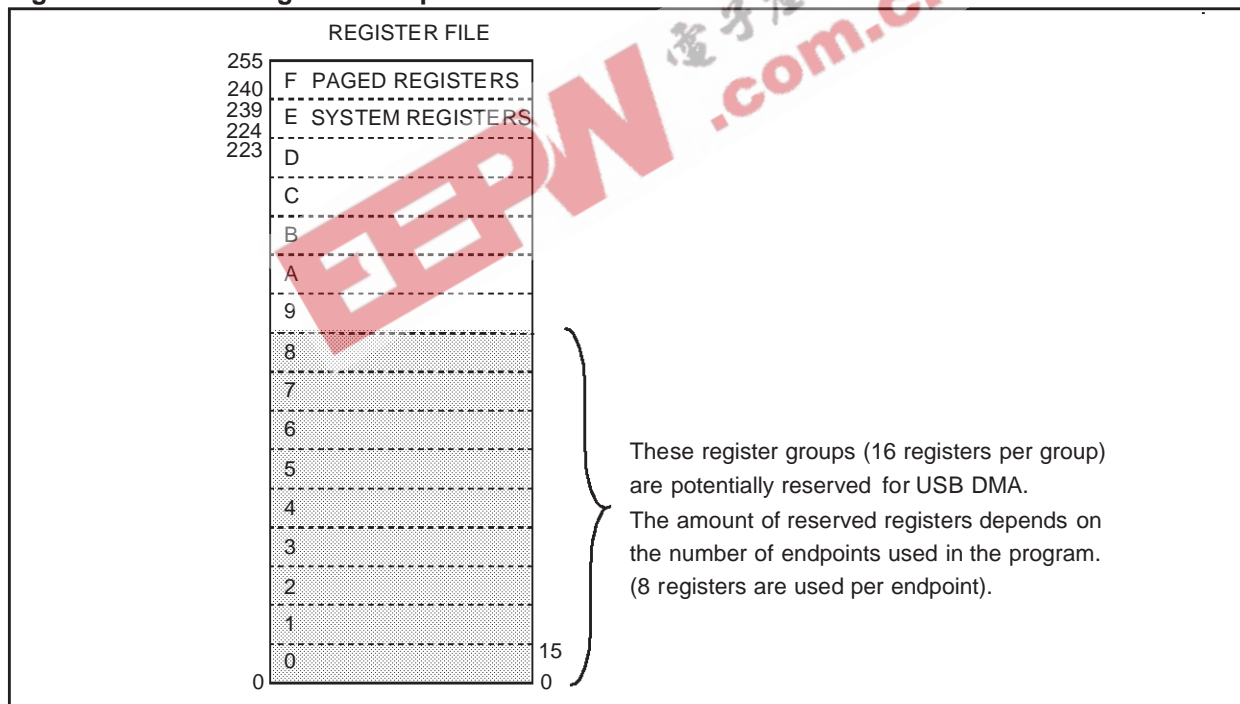

Table 6. Group F Pages Register Map

Resources available on the ST92163 device:

Register	Page														
	0	2	3	4	5	9	10	15	20	21	24	43	55	57	62
R255	Res.	Res.	Res.	USB Endpoints	Res.	MFT	USB Com- mon	I2C	MMU	SCI	Res.	Port 9	Res.	WUI MU	ADC
R254		Port 3													
R253	WCR														
R252															
R251	WDT	Port 6													
R250															
R249															
R248															
R247	EXT INT	Res.													
R246		Res.	Port 5												
R245															
R244															
R243	Res.														
R242	Res.	Port 4	MFT												
R241															
R240															

ST92163 - GENERAL DESCRIPTION

Table 7. Detailed Register Map

Page No.	Block	Reg. No.	Register Name	Description	Reset Value Hex.	Doc. Page
System	I/O Port 3:5	R227	P3DR	Port 3 Data Register	FF	98
		R228	P4DR	Port 4 Data Register	FF	
		R229	P5DR	Port 5 Data Register	FF	
	Core	R230	CICR	Central Interrupt Control Register	87	30
		R231	FLAGR	Flag Register	00	31
		R232	RP0	Pointer 0 Register	00	33
		R233	RP1	Pointer 1 Register	00	33
		R234	PPR	Page Pointer Register	54	35
		R235	MODER	Mode Register	E0	35
		R236	USPHR	User Stack Pointer High Register	xx	37
R237		USPLR	User Stack Pointer Low Register	xx	37	
R238		SSPHR	System Stack Pointer High Reg.	xx	37	
R239	SSPLR	System Stack Pointer Low Reg.	xx	37		
0	INT	R242	EITR	External Interrupt Trigger Register	00	59
		R243	EIPR	External Interrupt Pending Reg.	00	60
		R244	EIMR	External Interrupt Mask-bit Reg.	00	60
		R245	EIPLR	External Interrupt Priority Level Reg.	FF	60
		R246	EIVR	External Interrupt Vector Register	x6	61
		R247	NICR	Nested Interrupt Control	00	61
	WDT	R248	WDTHR	Watchdog Timer High Register	FF	109
		R249	WDTLR	Watchdog Timer Low Register	FF	109
		R250	WDTPR	Watchdog Timer Prescaler Reg.	FF	109
		R251	WDTCR	Watchdog Timer Control Register	12	109
R252	WCR	Wait Control Register	7F	110		
2	I/O Port 3	R252	P3C0	Port 3 Configuration Register 0	00	98
		R253	P3C1	Port 3 Configuration Register 1	00	
		R254	P3C2	Port 3 Configuration Register 2	00	
3	I/O Port 4	R240	P4C0	Port 4 Configuration Register 0	00	98
		R241	P4C1	Port 4 Configuration Register 1	00	
		R242	P4C2	Port 4 Configuration Register 2	00	
	I/O Port 5	R244	P5C0	Port 5 Configuration Register 0	00	
		R245	P5C1	Port 5 Configuration Register 1	00	
		R246	P5C2	Port 5 Configuration Register 2	00	
	I/O Port 6	R248	P6C0	Port 6 Configuration Register 0	00	
		R249	P6C1	Port 6 Configuration Register 1	00	
R250		P6C2	Port 6 Configuration Register 2	00		
R251		P6DR	Port 6 Data Register	FF		

Page No.	Block	Reg. No.	Register Name	Description	Reset Value Hex.	Doc. Page
4	USB End Points	R240	EP0RA	Endpoint 0 Register A (Transmission)	00	143
		R241	EP0RB	Endpoint 0 Register B (Reception)	00	
		R242	EP1RA	Endpoint 1 Register A (Transmission)	00	
		R243	EP1RB	Endpoint 1 Register B (Reception)	00	
		R244	EP2RA	Endpoint 2 Register A (Transmission)	00	
		R245	EP2RB	Endpoint 2 Register B (Reception)	00	
		R246	EP3RA	Endpoint 3 Register A (Transmission)	00	
		R247	EP3RB	Endpoint 3 Register B (Reception)	00	
		R248	EP4RA	Endpoint 4 Register A (Transmission)	00	
		R249	EP4RB	Endpoint 4 Register B (Reception)	00	
		R250	EP5RA	Endpoint 5 Register A (Transmission)	00	
		R251	EP5RB	Endpoint 5 Register B (Reception)	00	
		R252	EP6RA	Endpoint 6 Register A (Transmission)	00	
		R253	EP6RB	Endpoint 6 Register B (Reception)	00	
		R254	EP7RA	Endpoint 7 Register A (Transmission)	00	
R255	EP7RB	Endpoint 7 Register B (Reception)	00			
5	USB End Points	R240	EP8RA	Endpoint 8 Register A (Transmission)	00	
		R241	EP8RB	Endpoint 8 Register B (Reception)	00	
		R242	EP9RA	Endpoint 9 Register A (Transmission)	00	
		R243	EP9RB	Endpoint 9 Register B (Reception)	00	
		R244	EP10RA	Endpoint 10 Register A (Transmission)	00	
		R245	EP10RB	Endpoint 10 Register B (Reception)	00	
		R246	EP11RA	Endpoint 11 Register A (Transmission)	00	
		R247	EP11RB	Endpoint 11 Register B (Reception)	00	
		R248	EP12RA	Endpoint 12 Register A (Transmission)	00	
		R249	EP12RB	Endpoint 12 Register B (Reception)	00	
		R250	EP13RA	Endpoint 13 Register A (Transmission)	00	
R251	EP13RB	Endpoint 13 Register B (Reception)	00			
R252	EP14RA	Endpoint 14 Register A (Transmission)	00			
R253	EP14RB	Endpoint 14 Register B (Reception)	00			
R254	EP15RA	Endpoint 15 Register A (Transmission)	00			
R255	EP15RB	Endpoint 15 Register B (Reception)	00			
9	MFT	R240	DCPR	DMA Counter Pointer Register	xx	132
		R241	DAPR	DMA Address Pointer Register	xx	133
		R242	T_IVR	Interrupt Vector Register	xx	133
		R243	IDCR	Interrupt/DMA Control Register	C7	134
		R248	IOCR	I/O Connection Register	FC	134

ST92163 - GENERAL DESCRIPTION

Page No.	Block	Reg. No.	Register Name	Description	Reset Value Hex.	Doc. Page
10	MFT	R240	REG0HR	Capture Load Register 0 High	xx	125
		R241	REG0LR	Capture Load Register 0 Low	xx	125
		R242	REG1HR	Capture Load Register 1 High	xx	125
		R243	REG1LR	Capture Load Register 1 Low	xx	125
		R244	CMP0HR	Compare 0 Register High	00	125
		R245	CMP0LR	Compare 0 Register Low	00	125
		R246	CMP1HR	Compare 1 Register High	00	125
		R247	CMP1LR	Compare 1 Register Low	00	125
		R248	TCR	Timer Control Register	0x	126
		R249	TMR	Timer Mode Register	00	127
		R250	T_ICR	External Input Control Register	0x	128
		R251	PRSR	Prescaler Register	00	128
		R252	OACR	Output A Control Register	xx	129
		R253	OBCR	Output B Control Register	xx	130
		R254	T_FLAGR	Flags Register	00	31
R255	IDMR	Interrupt/DMA Mask Register	00	132		
15	USB Common	R240	DADDR0	Device Address Register 0	00	143
		R241	DADDR1	Device Address Register 1	00	
		R242	DADDR2	Device Address Register 2	00	
		R243	DADDR3	Device Address Register 3	00	
		R244	DADDR4	Device Address Register 4	00	
		R245	DADDR5	Device Address Register 5	00	
		R246	DADDR6	Device Address Register 6	00	
		R247	DADDR7	Device Address Register 7	00	
		R248	USBIVR	USB Interrupt Vector Register	xx	139
		R249	USBISTR	USB Interrupt Status Register	00	139
		R250	USBIMR	USB Interrupt Mask Register	00	140
		R251	USBIPR	USB Interrupt Priority Register	xx	140
		R252	USBCTLR	USB Control Register	17	141
		R253	CTRINF	CTR Interrupt Flags	xx	142
		R254	FNRH	Frame Number Register High	0x	142
R255	FNRL	Frame Number Register Low	xx	142		

Page No.	Block	Reg. No.	Register Name	Description	Reset Value Hex.	Doc. Page
20	I2C	R240	I2CCR	I ² C Control Register	00	186
		R241	I2CSR1	I ² C Status Register 1	00	187
		R242	I2CSR2	I ² C Status Register 2	00	189
		R243	I2CCCR	I ² C Clock Control Register	00	190
		R244	I2COAR1	I ² C Own Address Register 1	00	190
		R245	I2COAR2	I ² C Own Address Register 2	00	191
		R246	I2CDR	I ² C Data Register	00	191
		R247	I2CADR	I ² C General Call Address	A0	191
		R248	I2CISR	I ² C Interrupt Status Register	xx	192
		R249	I2CIVR	I ² C Interrupt Vector Register	xx	193
		R250	I2CRDAP	Receiver DMA Source Addr. Pointer	xx	193
		R251	I2CRDC	Receiver DMA Transaction Counter	xx	193
		R252	I2CTDAP	Transmitter DMA Source Addr. Pointer	xx	194
		R253	I2CTDC	Transmitter DMA Transaction Counter	xx	194
		R254	I2CECCR	I ² C Extended Clock Control Register	00	194
R255	I2CIMR	I ² C Interrupt Mask Register	x0	195		
21	MMU	R240	DPR0	Data Page Register 0	00	42
		R241	DPR1	Data Page Register 1	01	42
		R242	DPR2	Data Page Register 2	02	42
		R243	DPR3	Data Page Register 3	83	42
		R244	CSR	Code Segment Register	00	43
		R248	ISR	Interrupt Segment Register	x0	43
		R249	DMASR	DMA Segment Register	x0	43
	EXTMI	R245	EMR1	External Memory Register 1	80	95
		R246	EMR2	External Memory Register 2	0F	96
24	SCI	R240	RDCPR	Receiver DMA Transaction Counter Pointer	xx	165
		R241	RDAPR	Receiver DMA Source Address Pointer	xx	165
		R242	TDCPR	Transmitter DMA Transaction Counter Pointer	xx	165
		R243	TDAPR	Transmitter DMA Destination Address Pointer	xx	165
		R244	S_IVR	Interrupt Vector Register	xx	166
		R245	ACR	Address/Data Compare Register	xx	166
		R246	IMR	Interrupt Mask Register	x0	167
		R247	S_ISR	Interrupt Status Register	xx	43
		R248	RXBR	Receive Buffer Register	xx	169
		R248	TXBR	Transmitter Buffer Register	xx	169
		R249	IDPR	Interrupt/DMA Priority Register	xx	170
		R250	CHCR	Character Configuration Register	xx	171
		R251	CCR	Clock Configuration Register	00	172
		R252	BRGHR	Baud Rate Generator High Reg.	xx	173
		R253	BRGLR	Baud Rate Generator Low Register	xx	173
R254	SICR	Synchronous Input Control	03	173		
R255	SOCR	Synchronous Output Control	01	174		

ST92163 - GENERAL DESCRIPTION

Page No.	Block	Reg. No.	Register Name	Description	Reset Value Hex.	Doc. Page
43	I/O Port 8	R248	P8C0	Port 8 Configuration Register 0	00	98
		R249	P8C1	Port 8 Configuration Register 1	00	
		R250	P8C2	Port 8 Configuration Register 2	00	
		R251	P8DR	Port 8 Data Register	FF	
	I/O Port 9	R252	P9C0	Port 9 Configuration Register 0	00	
		R253	P9C1	Port 9 Configuration Register 1	00	
		R254	P9C2	Port 9 Configuration Register 2	00	
		R255	P9DR	Port 9 Data Register	FF	
55	RCCU	R240	CLKCTL	Clock Control Register	00	81
		R242	CLK_FLAG	Clock Flag Register	48, 28 or 08	82
		R246	PLLCONF	PLL Configuration Register	xx	83
59	WUIMU	R249	WUCTRL	Wake-Up Control Register	00	67
		R250	WUMRH	Wake-Up Mask Register High	00	68
		R251	WUMRL	Wake-Up Mask Register Low	00	68
		R252	WUTRH	Wake-Up Trigger Register High	00	69
		R253	WUTRL	Wake-Up Trigger Register Low	00	69
		R254	WUPRH	Wake-Up Pending Register High	00	69
		R255	WUPRL	Wake-Up Pending Register Low	00	69
60	USB	R244	DEVCONF1	USB device configuration 1	0F	146
		R245	DEVCONF2	USB device configuration 2	00	146
		R246	MIRRA	Mirror Register A	xx	147
		R247	MIRRB	Mirror Register B	xx	147
62	ADC	R240	ADDTR	Channel i Data Register	xx	199
		R241	ADCLR	Control Logic Register	00	199
		R242	ADINT	AD Interrupt Register	01	200

Note: xx denotes a byte with an undefined value, but some bits may have defined values. See register description for details.

2 DEVICE ARCHITECTURE

2.1 CORE ARCHITECTURE

The ST9+ Core or Central Processing Unit (CPU) features a highly optimised instruction set, capable of handling bit, byte (8-bit) and word (16-bit) data, as well as BCD and Boolean formats; 14 addressing modes are available.

Four independent buses are controlled by the Core: a 16-bit Memory bus, an 8-bit Register data bus, an 8-bit Register address bus and a 6-bit Interrupt/DMA bus which connects the interrupt and DMA controllers in the on-chip peripherals with the Core.

This multiple bus architecture affords a high degree of pipelining and parallel operation, thus making the ST9+ family devices highly efficient, both for numerical calculation, data handling and with regard to communication with on-chip peripheral resources.

2.2 MEMORY SPACES

There are two separate memory spaces:

- The Register File, which comprises 240 8-bit registers, arranged as 15 groups (Group 0 to E), each containing sixteen 8-bit registers plus up to 64 pages of 16 registers mapped in Group F,

which hold data and control bits for the on-chip peripherals and I/Os.

- A single linear memory space accommodating both program and data. All of the physically separate memory areas, including the internal ROM, internal RAM and external memory are mapped in this common address space. The total addressable memory space of 4 Mbytes (limited by the size of on-chip memory and the number of external address pins) is arranged as 64 segments of 64 Kbytes. Each segment is further subdivided into four pages of 16 Kbytes, as illustrated in Figure 1. A Memory Management Unit uses a set of pointer registers to address a 22-bit memory field using 16-bit address-based instructions.

2.2.1 Register File

The Register File consists of (see Figure 2):

- 224 general purpose registers (Group 0 to D, registers R0 to R223)
- 6 system registers in the System Group (Group E, registers R224 to R239)
- Up to 64 pages, depending on device configuration, each containing up to 16 registers, mapped to Group F (R240 to R255), see Figure 3.

Figure 7. Single Program and Data Memory Address Space

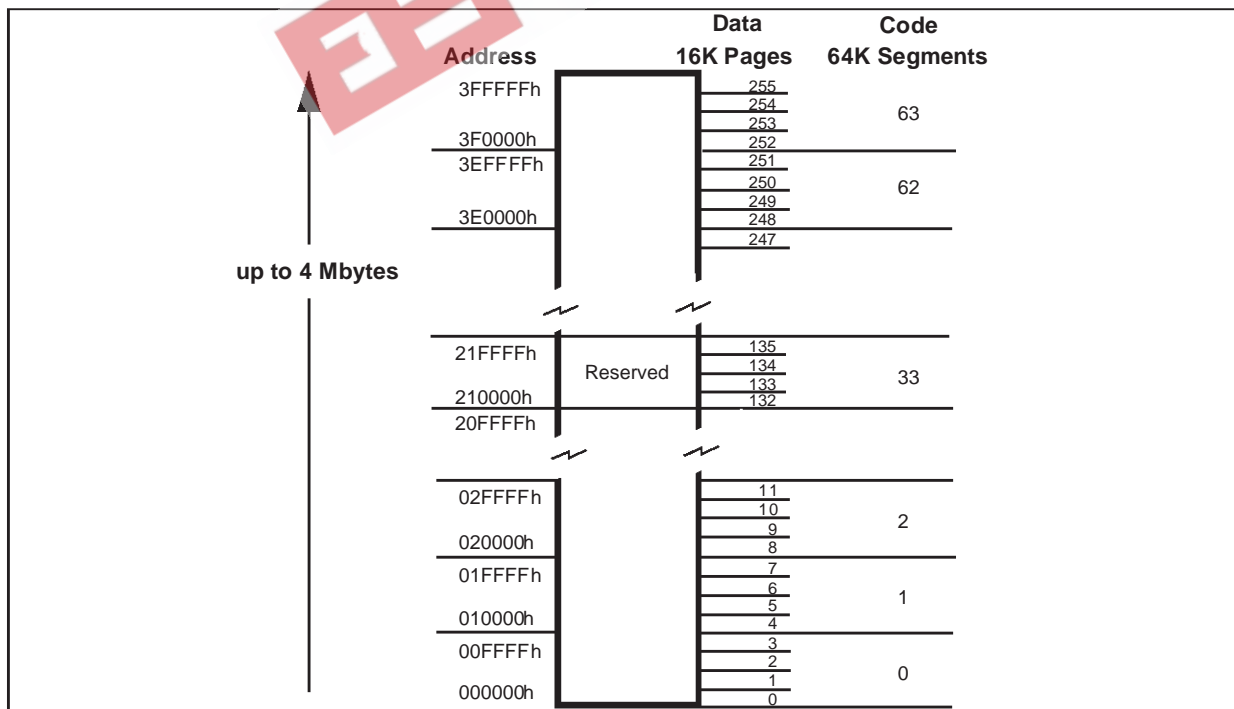

MEMORY SPACES (Cont'd)

Figure 8. Register Groups

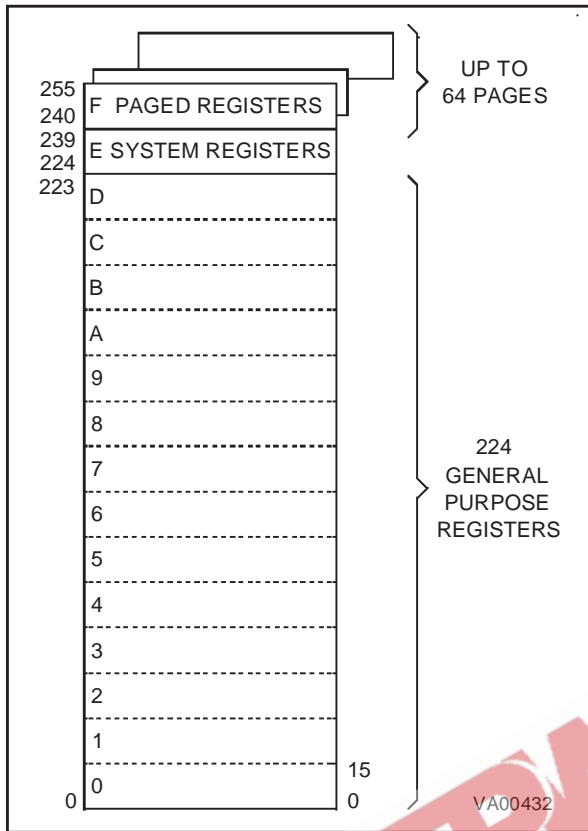

Figure 9. Page Pointer for Group F mapping

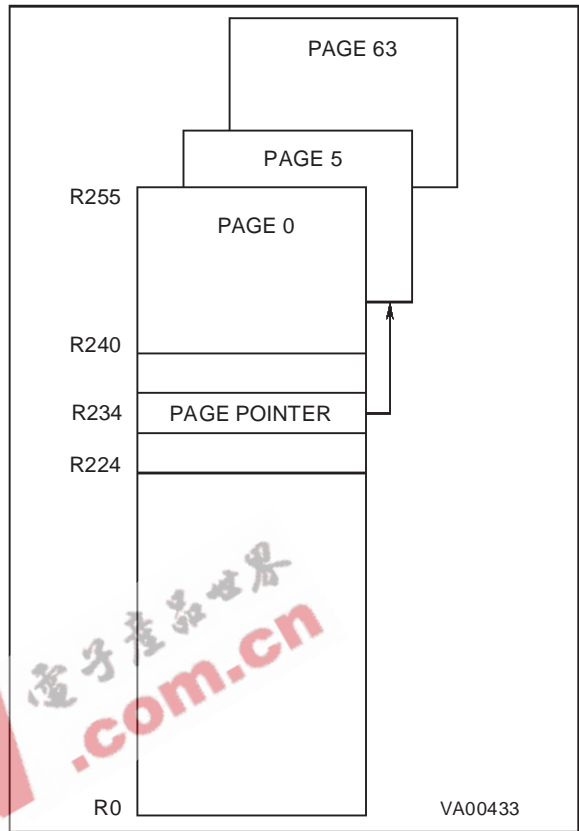
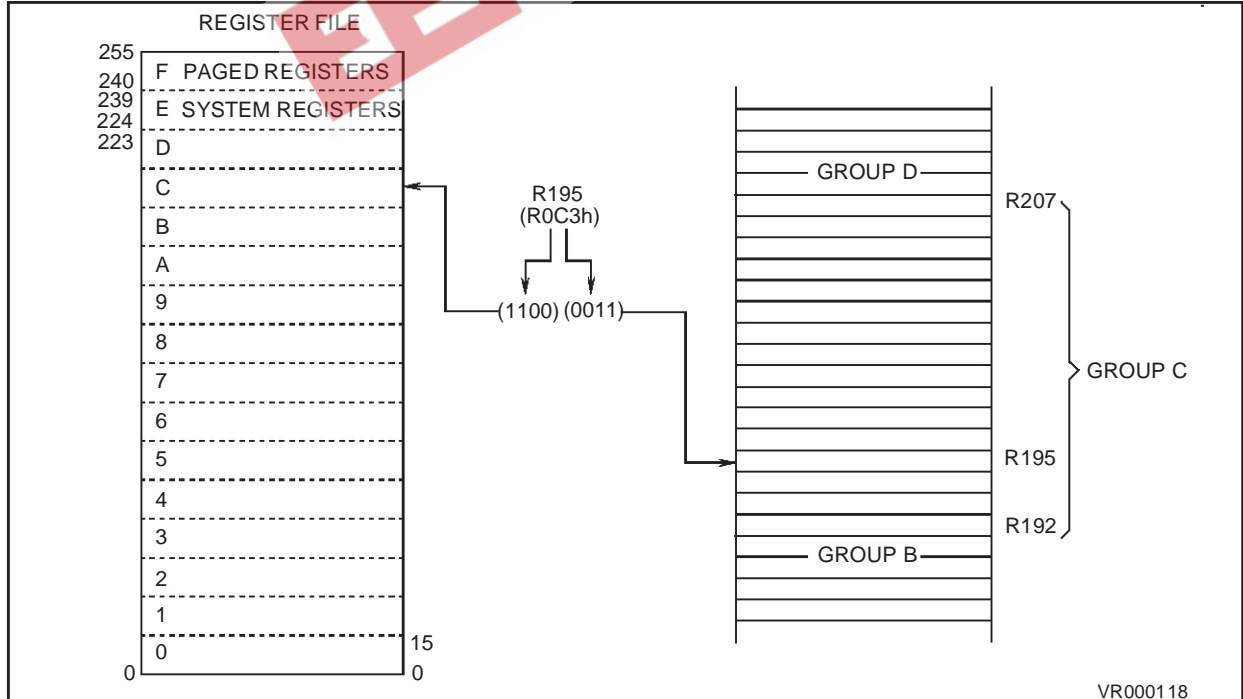

Figure 10. Addressing the Register File



MEMORY SPACES (Cont'd)

2.2.2 Register Addressing

Register File registers, including Group F paged registers (but excluding Group D), may be addressed explicitly by means of a decimal, hexadecimal or binary address; thus R231, RE7h and R11100111b represent the same register (see Figure 4). Group D registers can only be addressed in Working Register mode.

Note that an upper case “R” is used to denote this direct addressing mode.

Working Registers

Certain types of instruction require that registers be specified in the form “rx”, where x is in the range 0 to 15: these are known as Working Registers.

Note that a lower case “r” is used to denote this indirect addressing mode.

Two addressing schemes are available: a single group of 16 working registers, or two separately mapped groups, each consisting of 8 working registers. These groups may be mapped starting at any 8 or 16 byte boundary in the register file by means of dedicated pointer registers. This technique is described in more detail in Section 1.3.3, and illustrated in Figure 5 and in Figure 6.

System Registers

The 16 registers in Group E (R224 to R239) are System registers and may be addressed using any of the register addressing modes. These registers are described in greater detail in Section 1.3.

Paged Registers

Up to 64 pages, each containing 16 registers, may be mapped to Group F. These are addressed using any register addressing mode, in conjunction with the Page Pointer register, R234, which is one of the System registers. This register selects the page to be mapped to Group F and, once set, does not need to be changed if two or more registers on the same page are to be addressed in succession.

Therefore if the Page Pointer, R234, is set to 5, the instructions:

```
spp #5
ld R242, r4
```

will load the contents of working register r4 into the third register of page 5 (R242).

These paged registers hold data and control information relating to the on-chip peripherals, each peripheral always being associated with the same pages and registers to ensure code compatibility between ST9+ devices. The number of these registers therefore depends on the peripherals which are present in the specific ST9+ family device. In other words, pages only exist if the relevant peripheral is present.

Table 8. Register File Organization

Hex. Address	Decimal Address	Function	Register File Group
F0-FF	240-255	Paged Registers	Group F
E0-EF	224-239	System Registers	Group E
D0-DF	208-223	General Purpose Registers	Group D
C0-CF	192-207		Group C
B0-BF	176-191		Group B
A0-AF	160-175		Group A
90-9F	144-159		Group 9
80-8F	128-143		Group 8
70-7F	112-127		Group 7
60-6F	96-111		Group 6
50-5F	80-95		Group 5
40-4F	64-79		Group 4
30-3F	48-63		Group 3
20-2F	32-47		Group 2
10-1F	16-31		Group 1
00-0F	00-15		Group 0

2.3 SYSTEM REGISTERS

The System registers are listed in Table 2 System Registers (Group E). They are used to perform all the important system settings. Their purpose is described in the following pages. Refer to the chapter dealing with I/O for a description of the PORT[5:0] Data registers.

Table 9. System Registers (Group E)

R239 (EFh)	SSPLR
R238 (EEh)	SSPHR
R237 (EDh)	USPLR
R236 (ECh)	USPHR
R235 (EBh)	MODE REGISTER
R234 (EAh)	PAGE POINTER REGISTER
R233 (E9h)	REGISTER POINTER 1
R232 (E8h)	REGISTER POINTER 0
R231 (E7h)	FLAG REGISTER
R230 (E6h)	CENTRAL INT. CNTL REG
R229 (E5h)	PORT5 DATA REG.
R228 (E4h)	PORT4 DATA REG.
R227 (E3h)	PORT3 DATA REG.
R226 (E2h)	PORT2 DATA REG.
R225 (E1h)	PORT1 DATA REG.
R224 (E0h)	PORT0 DATA REG.

2.3.1 Central Interrupt Control Register

Please refer to the "INTERRUPT" chapter for a detailed description of the ST9 interrupt philosophy.

CENTRAL INTERRUPT CONTROL REGISTER (CICR)

R230 - Read/Write
 Register Group: E (System)
 Reset Value: 1000 0111 (87h)

7							0
GCEN	TLIP	TLI	IEN	IAM	CPL2	CPL1	CPL0

Bit 7 = **GCEN**: *Global Counter Enable*.
 This bit is the Global Counter Enable of the Multi-function Timers. The GCEN bit is ANDed with the CE bit in the TCR Register (only in devices featuring the MFT Multifunction Timer) in order to enable the Timers when both bits are set. This bit is set after the Reset cycle.

Note: If an MFT is not included in the ST9 device, then this bit has no effect.

Bit 6 = **TLIP**: *Top Level Interrupt Pending*.
 This bit is set by hardware when a Top Level Interrupt Request is recognized. This bit can also be set by software to simulate a Top Level Interrupt Request.

0: No Top Level Interrupt pending
 1: Top Level Interrupt pending

Bit 5 = **TLI**: *Top Level Interrupt bit*.
 0: Top Level Interrupt is acknowledged depending on the TLNM bit in the NICR Register.
 1: Top Level Interrupt is acknowledged depending on the IEN and TLNM bits in the NICR Register (described in the Interrupt chapter).

Bit 4 = **IEN**: *Interrupt Enable*.
 This bit is cleared by interrupt acknowledgement, and set by interrupt return (*iret*). IEN is modified implicitly by *iret*, *ei* and *di* instructions or by an interrupt acknowledge cycle. It can also be explicitly written by the user, but only when no interrupt is pending. Therefore, the user should execute a *di* instruction (or guarantee by other means that no interrupt request can arrive) before any write operation to the CICR register.
 0: Disable all interrupts except Top Level Interrupt.
 1: Enable Interrupts

Bit 3 = **IAM**: *Interrupt Arbitration Mode*.
 This bit is set and cleared by software to select the arbitration mode.
 0: Concurrent Mode
 1: Nested Mode.

Bit 2:0 = **CPL[2:0]**: *Current Priority Level*.
 These three bits record the priority level of the routine currently running (i.e. the Current Priority Level, CPL). The highest priority level is represented by 000, and the lowest by 111. The CPL bits can be set by hardware or software and provide the reference according to which subsequent interrupts are either left pending or are allowed to interrupt the current interrupt service routine. When the current interrupt is replaced by one of a higher priority, the current priority value is automatically stored until required in the NICR register.

SYSTEM REGISTERS (Cont'd)

2.3.2 Flag Register

The Flag Register contains 8 flags which indicate the CPU status. During an interrupt, the flag register is automatically stored in the system stack area and recalled at the end of the interrupt service routine, thus returning the CPU to its original status.

This occurs for all interrupts and, when operating in nested mode, up to seven versions of the flag register may be stored.

FLAG REGISTER (FLAGR)

R231- Read/Write

Register Group: E (System)

Reset value: 0000 0000 (00h)

7							0
C	Z	S	V	DA	H	-	DP

Bit 7 = **C**: Carry Flag.

The carry flag is affected by:

Addition (add, addw, adc, adcw),
 Subtraction (sub, subw, sbc, sbcw),
 Compare (cp, cpw),
 Shift Right Arithmetic (sra, srarw),
 Shift Left Arithmetic (sla, slarw),
 Swap Nibbles (swap),
 Rotate (rrc, rrcw, rlc, rlcw, ror, rol),
 Decimal Adjust (da),
 Multiply and Divide (mul, div, divws).

When set, it generally indicates a carry out of the most significant bit position of the register being used as an accumulator (bit 7 for byte operations and bit 15 for word operations).

The carry flag can be set by the Set Carry Flag (scf) instruction, cleared by the Reset Carry Flag (rcf) instruction, and complemented by the Complement Carry Flag (ccf) instruction.

Bit 6 = **Z**: Zero Flag. The Zero flag is affected by:

Addition (add, addw, adc, adcw),
 Subtraction (sub, subw, sbc, sbcw),
 Compare (cp, cpw),
 Shift Right Arithmetic (sra, srarw),
 Shift Left Arithmetic (sla, slarw),
 Swap Nibbles (swap),
 Rotate (rrc, rrcw, rlc, rlcw, ror, rol),
 Decimal Adjust (da),
 Multiply and Divide (mul, div, divws),
 Logical (and, andw, or, orw, xor, xorw, cpl),
 Increment and Decrement (inc, incw, dec,

decw),

Test (tm, tmw, tcm, tcmw, btset).

In most cases, the Zero flag is set when the contents of the register being used as an accumulator become zero, following one of the above operations.

Bit 5 = **S**: Sign Flag.

The Sign flag is affected by the same instructions as the Zero flag.

The Sign flag is set when bit 7 (for a byte operation) or bit 15 (for a word operation) of the register used as an accumulator is one.

Bit 4 = **V**: Overflow Flag.

The Overflow flag is affected by the same instructions as the Zero and Sign flags.

When set, the Overflow flag indicates that a two's-complement number, in a result register, is in error, since it has exceeded the largest (or is less than the smallest) number that can be represented in two's-complement notation.

Bit 3 = **DA**: Decimal Adjust Flag.

The DA flag is used for BCD arithmetic. Since the algorithm for correcting BCD operations is different for addition and subtraction, this flag is used to specify which type of instruction was executed last, so that the subsequent Decimal Adjust (da) operation can perform its function correctly. The DA flag cannot normally be used as a test condition by the programmer.

Bit 2 = **H**: Half Carry Flag.

The H flag indicates a carry out of (or a borrow into) bit 3, as the result of adding or subtracting two 8-bit bytes, each representing two BCD digits. The H flag is used by the Decimal Adjust (da) instruction to convert the binary result of a previous addition or subtraction into the correct BCD result. Like the DA flag, this flag is not normally accessed by the user.

Bit 1 = Reserved bit (must be 0).

Bit 0 = **DP**: Data/Program Memory Flag.

This bit indicates the memory area addressed. Its value is affected by the Set Data Memory (sdm) and Set Program Memory (spm) instructions. Refer to the Memory Management Unit for further details.

SYSTEM REGISTERS (Cont'd)

If the bit is set, data is accessed using the Data Pointers (DPRs registers), otherwise it is pointed to by the Code Pointer (CSR register); therefore, the user initialization routine must include a `Sdm` instruction. Note that code is always pointed to by the Code Pointer (CSR).

Note: In the ST9+, the DP flag is only for compatibility with software developed for the first generation of ST9 devices. With the single memory addressing space, its use is now redundant. It must be kept to 1 with a `Sdm` instruction at the beginning of the program to ensure a normal use of the different memory pointers.

2.3.3 Register Pointing Techniques

Two registers within the System register group, are used as pointers to the working registers. Register Pointer 0 (R232) may be used on its own as a single pointer to a 16-register working space, or in conjunction with Register Pointer 1 (R233), to point to two separate 8-register spaces.

For the purpose of register pointing, the 16 register groups of the register file are subdivided into 32 8-register blocks. The values specified with the Set Register Pointer instructions refer to the blocks to be pointed to in twin 8-register mode, or to the lower 8-register block location in single 16-register mode.

The Set Register Pointer instructions `srp`, `srp0` and `srp1` automatically inform the CPU whether the Register File is to operate in single 16-register mode or in twin 8-register mode. The `srp` instruction selects the single 16-register group mode and

specifies the location of the lower 8-register block, while the `srp0` and `srp1` instructions automatically select the twin 8-register group mode and specify the locations of each 8-register block.

There is no limitation on the order or position of these register groups, other than that they must start on an 8-register boundary in twin 8-register mode, or on a 16-register boundary in single 16-register mode.

The block number should always be an even number in single 16-register mode. The 16-register group will always start at the block whose number is the nearest even number equal to or lower than the block number specified in the `srp` instruction. Avoid using odd block numbers, since this can be confusing if twin mode is subsequently selected.

Thus:

`srp #3` will be interpreted as `srp #2` and will allow using R16..R31 as r0..r15.

In single 16-register mode, the working registers are referred to as r0 to r15. In twin 8-register mode, registers r0 to r7 are in the block pointed to by RP0 (by means of the `srp0` instruction), while registers r8 to r15 are in the block pointed to by RP1 (by means of the `srp1` instruction).

Caution: Group D registers can only be accessed as working registers using the Register Pointers, or by means of the Stack Pointers. They cannot be addressed explicitly in the form "Rxxx".

SYSTEM REGISTERS (Cont'd)**POINTER 0 REGISTER (RP0)**

R232 - Read/Write

Register Group: E (System)

Reset Value: xxxx xx00 (xxh)

7							0
RG4	RG3	RG2	RG1	RG0	RPS	0	0

Bit 7:3 = **RG[4:0]**: *Register Group number*. These bits contain the number (in the range 0 to 31) of the register block specified in the `srp0` or `srp` instructions. In single 16-register mode the number indicates the lower of the two 8-register blocks to which the 16 working registers are to be mapped, while in twin 8-register mode it indicates the 8-register block to which `r0` to `r7` are to be mapped.

Bit 2 = **RPS**: *Register Pointer Selector*.

This bit is set by the instructions `srp0` and `srp1` to indicate that the twin register pointing mode is selected. The bit is reset by the `srp` instruction to indicate that the single register pointing mode is selected.

0: Single register pointing mode

1: Twin register pointing mode

Bit 1:0: Reserved. Forced by hardware to zero.

POINTER 1 REGISTER (RP1)

R233 - Read/Write

Register Group: E (System)

Reset Value: xxxx xx00 (xxh)

7							0
RG4	RG3	RG2	RG1	RG0	RPS	0	0

This register is only used in the twin register pointing mode. When using the single register pointing mode, or when using only one of the twin register groups, the RP1 register must be considered as RESERVED and may NOT be used as a general purpose register.

Bit 7:3 = **RG[4:0]**: *Register Group number*. These bits contain the number (in the range 0 to 31) of the 8-register block specified in the `srp1` instruction, to which `r8` to `r15` are to be mapped.

Bit 2 = **RPS**: *Register Pointer Selector*.

This bit is set by the `srp0` and `srp1` instructions to indicate that the twin register pointing mode is selected. The bit is reset by the `srp` instruction to indicate that the single register pointing mode is selected.

0: Single register pointing mode

1: Twin register pointing mode

Bit 1:0: Reserved. Forced by hardware to zero.

SYSTEM REGISTERS (Cont'd)

Figure 11. Pointing to a single group of 16 registers

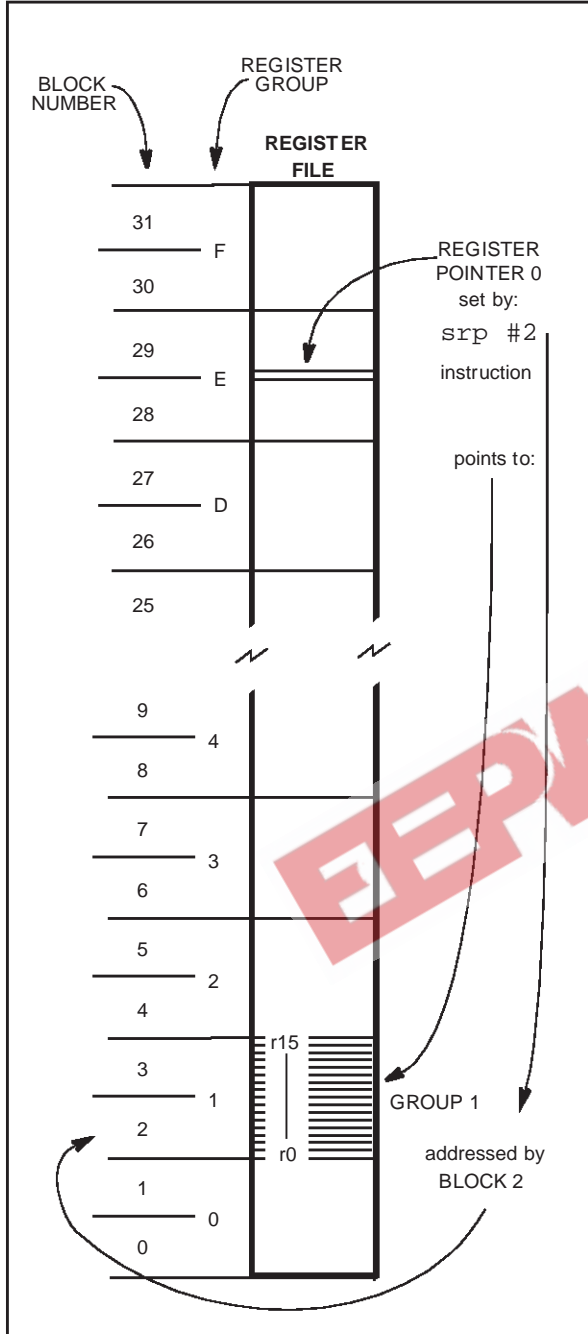
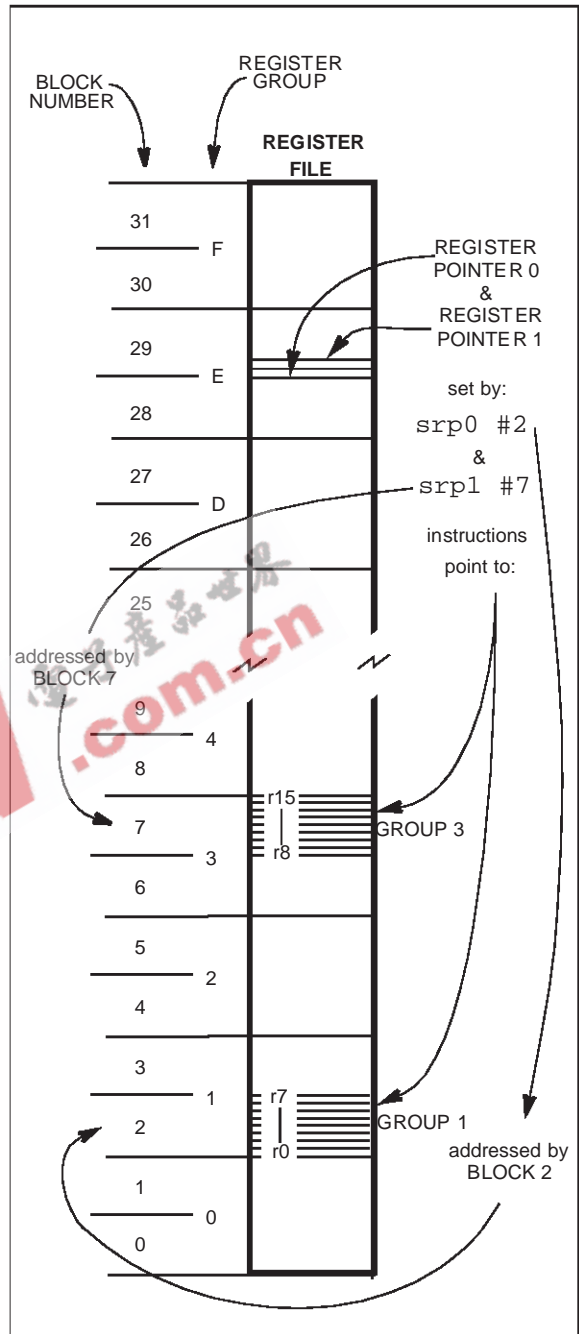

Figure 12. Pointing to two groups of 8 registers



SYSTEM REGISTERS (Cont'd)

2.3.4 Paged Registers

Up to 64 pages, each containing 16 registers, may be mapped to Group F. These paged registers hold data and control information relating to the on-chip peripherals, each peripheral always being associated with the same pages and registers to ensure code compatibility between ST9+ devices. The number of these registers depends on the peripherals present in the specific ST9 device. In other words, pages only exist if the relevant peripheral is present.

The paged registers are addressed using the normal register addressing modes, in conjunction with the Page Pointer register, R234, which is one of the System registers. This register selects the page to be mapped to Group F and, once set, does not need to be changed if two or more registers on the same page are to be addressed in succession.

Thus the instructions:

```
spp #5
ld R242, r4
```

will load the contents of working register r4 into the third register of page 5 (R242).

Warning: During an interrupt, the PPR register is not saved automatically in the stack. If needed, it should be saved/restored by the user within the interrupt routine.

PAGE POINTER REGISTER (PPR)

R234 - Read/Write
Register Group: E (System)
Reset value: xxxx xx00 (xxh)

7							0	
PP5	PP4	PP3	PP2	PP1	PP0	0	0	

Bit 7:2 = **PP[5:0]: Page Pointer.**
These bits contain the number (in the range 0 to 63) of the page specified in the spp instruction. Once the page pointer has been set, there is no need to refresh it unless a different page is required.

Bit 1:0: Reserved. Forced by hardware to 0.

2.3.5 Mode Register

The Mode Register allows control of the following operating parameters:

- Selection of internal or external System and User Stack areas,
- Management of the clock frequency,
- Enabling of Bus request and Wait signals when interfacing to external memory.

MODE REGISTER (MODER)

R235 - Read/Write
Register Group: E (System)
Reset value: 1110 0000 (E0h)

7							0	
SSP	USP	DIV2	PRS2	PRS1	PRS0	BRQEN	HIMP	

Bit 7 = **SSP: System Stack Pointer.**
This bit selects an internal or external System Stack area.
0: External system stack area, in memory space.
1: Internal system stack area, in the Register File (reset state).

Bit 6 = **USP: User Stack Pointer.**
This bit selects an internal or external User Stack area.
0: External user stack area, in memory space.
1: Internal user stack area, in the Register File (reset state).

Bit 5 = **DIV2: OSCIN Clock Divided by 2.**
This bit controls the divide-by-2 circuit operating on OSCIN.
0: Clock divided by 1
1: Clock divided by 2

Bit 4:2 = **PRS[2:0]: CPUCLK Prescaler.**
These bits load the prescaler division factor for the internal clock (INTCLK). The prescaler factor selects the internal clock frequency, which can be divided by a factor from 1 to 8. Refer to the Reset and Clock Control chapter for further information.

Bit 1 = **BRQEN: Bus Request Enable.**
0: External Memory Bus Request disabled
1: External Memory Bus Request enabled on the BREQ pin (where available).

Bit 0 = **HIMP: High Impedance Enable.**
When any of Ports 0, 1, 2 or 6 depending on device configuration, are programmed as Address and Data lines to interface external Memory, these lines and the Memory interface control lines (AS,

SYSTEM REGISTERS (Cont'd)

DS, R/W) can be forced into the High Impedance state by setting the HIMP bit. When this bit is reset, it has no effect.

Setting the HIMP bit is recommended for noise reduction when only internal Memory is used.

If Port 1 and/or 2 are declared as an address AND as an I/O port (for example: P10... P14 = Address, and P15... P17 = I/O), the HIMP bit has no effect on the I/O lines.

2.3.6 Stack Pointers

Two separate, double-register stack pointers are available: the System Stack Pointer and the User Stack Pointer, both of which can address registers or memory.

The stack pointers point to the “bottom” of the stacks which are filled using the push commands and emptied using the pop commands. The stack pointer is automatically pre-decremented when data is “pushed” in and post-incremented when data is “popped” out.

The push and pop commands used to manage the System Stack may be addressed to the User Stack by adding the suffix “u”. To use a stack instruction for a word, the suffix “w” is added. These suffixes may be combined.

When bytes (or words) are “popped” out from a stack, the contents of the stack locations are unchanged until fresh data is loaded. Thus, when data is “popped” from a stack area, the stack contents remain unchanged.

Note: Instructions such as: `pushuw RR236` or `pushw RR238`, as well as the corresponding `pop` instructions (where R236 & R237, and R238 & R239 are themselves the user and system stack pointers respectively), must not be used, since the pointer values are themselves automatically changed by the `push` or `pop` instruction, thus corrupting their value.

System Stack

The System Stack is used for the temporary storage of system and/or control data, such as the Flag register and the Program counter.

The following automatically push data onto the System Stack:

– **Interrupts**

When entering an interrupt, the PC and the Flag Register are pushed onto the System Stack. If the ENCSR bit in the EMR2 register is set, then the

Code Segment Register is also pushed onto the System Stack.

– **Subroutine Calls**

When a `call` instruction is executed, only the PC is pushed onto stack, whereas when a `calls` instruction (call segment) is executed, both the PC and the Code Segment Register are pushed onto the System Stack.

– **Link Instruction**

The `link` or `linku` instructions create a C language stack frame of user-defined length in the System or User Stack.

All of the above conditions are associated with their counterparts, such as return instructions, which pop the stored data items off the stack.

User Stack

The User Stack provides a totally user-controlled stacking area.

The User Stack Pointer consists of two registers, R236 and R237, which are both used for addressing a stack in memory. When stacking in the Register File, the User Stack Pointer High Register, R236, becomes redundant but must be considered as reserved.

Stack Pointers

Both System and User stacks are pointed to by double-byte stack pointers. Stacks may be set up in RAM or in the Register File. Only the lower byte will be required if the stack is in the Register File. The upper byte must then be considered as reserved and must not be used as a general purpose register.

The stack pointer registers are located in the System Group of the Register File, this is illustrated in Table 2 System Registers (Group E).

Stack location

Care is necessary when managing stacks as there is no limit to stack sizes apart from the bottom of any address space in which the stack is placed. Consequently programmers are advised to use a stack pointer value as high as possible, particularly when using the Register File as a stacking area.

Group D is a good location for a stack in the Register File, since it is the highest available area. The stacks may be located anywhere in the first 14 groups of the Register File (internal stacks) or in RAM (external stacks).

Note. Stacks must not be located in the Paged Register Group or in the System Register Group.

SYSTEM REGISTERS (Cont'd)

USER STACK POINTER HIGH REGISTER (USPHR)

R236 - Read/Write
 Register Group: E (System)
 Reset value: undefined



USER STACK POINTER LOW REGISTER (USPLR)

R237 - Read/Write
 Register Group: E (System)
 Reset value: undefined

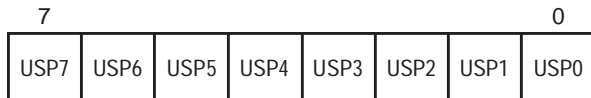
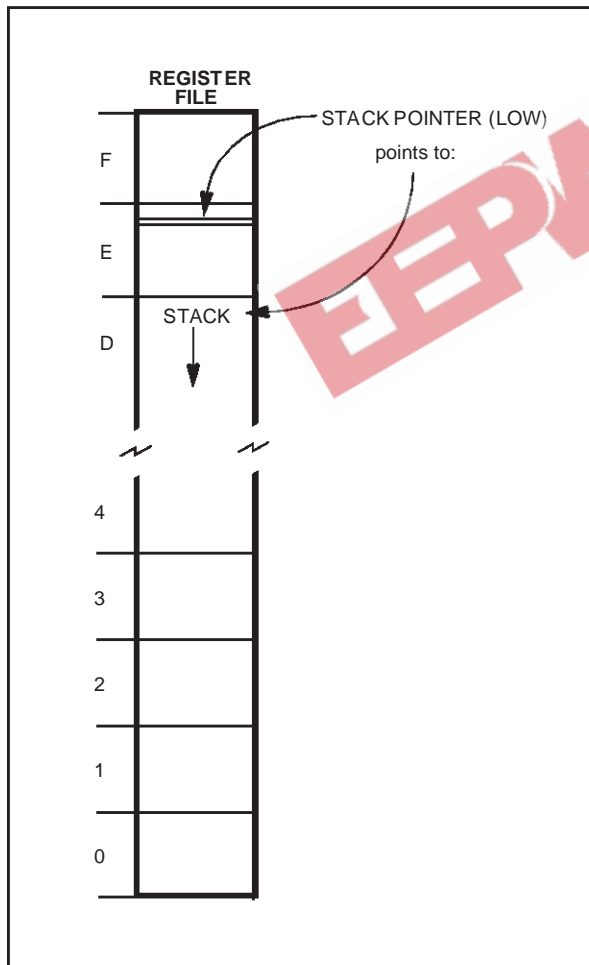
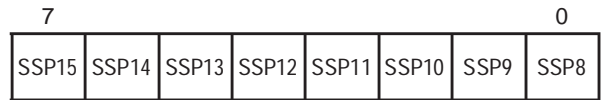

Figure 13. Internal Stack Mode



SYSTEM STACK POINTER HIGH REGISTER (SSPHR)

R238 - Read/Write
 Register Group: E (System)
 Reset value: undefined



SYSTEM STACK POINTER LOW REGISTER (SSPLR)

R239 - Read/Write
 Register Group: E (System)
 Reset value: undefined

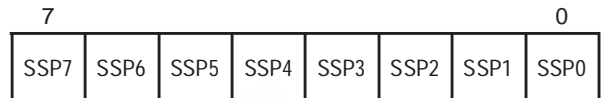
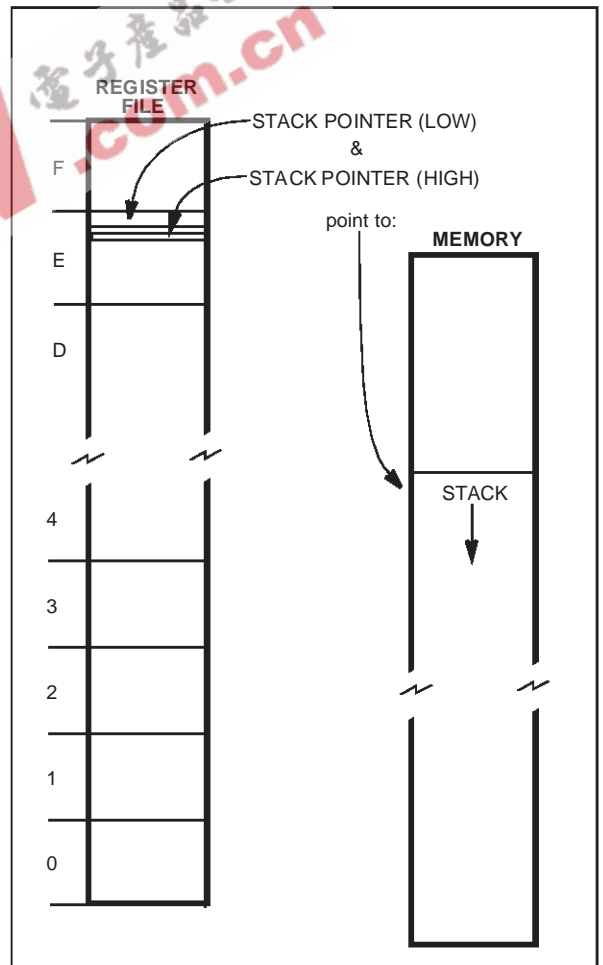

Figure 14. External Stack Mode



2.4 MEMORY ORGANIZATION

Code and data are accessed within the same linear address space. All of the physically separate memory areas, including the internal ROM, internal RAM and external memory are mapped in a common address space.

The ST9+ provides a total addressable memory space of 4 Mbytes. This address space is arranged as 64 segments of 64 Kbytes; each segment is again subdivided into four 16 Kbyte pages.

The mapping of the various memory areas (internal RAM or ROM, external memory) differs from device to device. Each 64-Kbyte physical memory segment is mapped either internally or externally; if the memory is internal and smaller than 64 Kbytes, the remaining locations in the 64-Kbyte segment are not used (reserved).

Refer to the Register and Memory Map Chapter for more details on the memory map.

EEPW 电子產品世界
.com.cn

2.5 MEMORY MANAGEMENT UNIT

The CPU Core includes a Memory Management Unit (MMU) which must be programmed to perform memory accesses (even if external memory is not used).

The MMU is controlled by 7 registers and 2 bits (ENCSR and DPRREM) present in EMR2, which may be written and read by the user program. These registers are mapped within group F, Page 21 of the Register File. The 7 registers may be

sub-divided into 2 main groups: a first group of four 8-bit registers (DPR[3:0]), and a second group of three 6-bit registers (CSR, ISR, and DMASR). The first group is used to extend the address during Data Memory access (DPR[3:0]). The second is used to manage Program and Data Memory accesses during Code execution (CSR), Interrupts Service Routines (ISR or CSR), and DMA transfers (DMASR or ISR).

Figure 15. Page 21 Registers

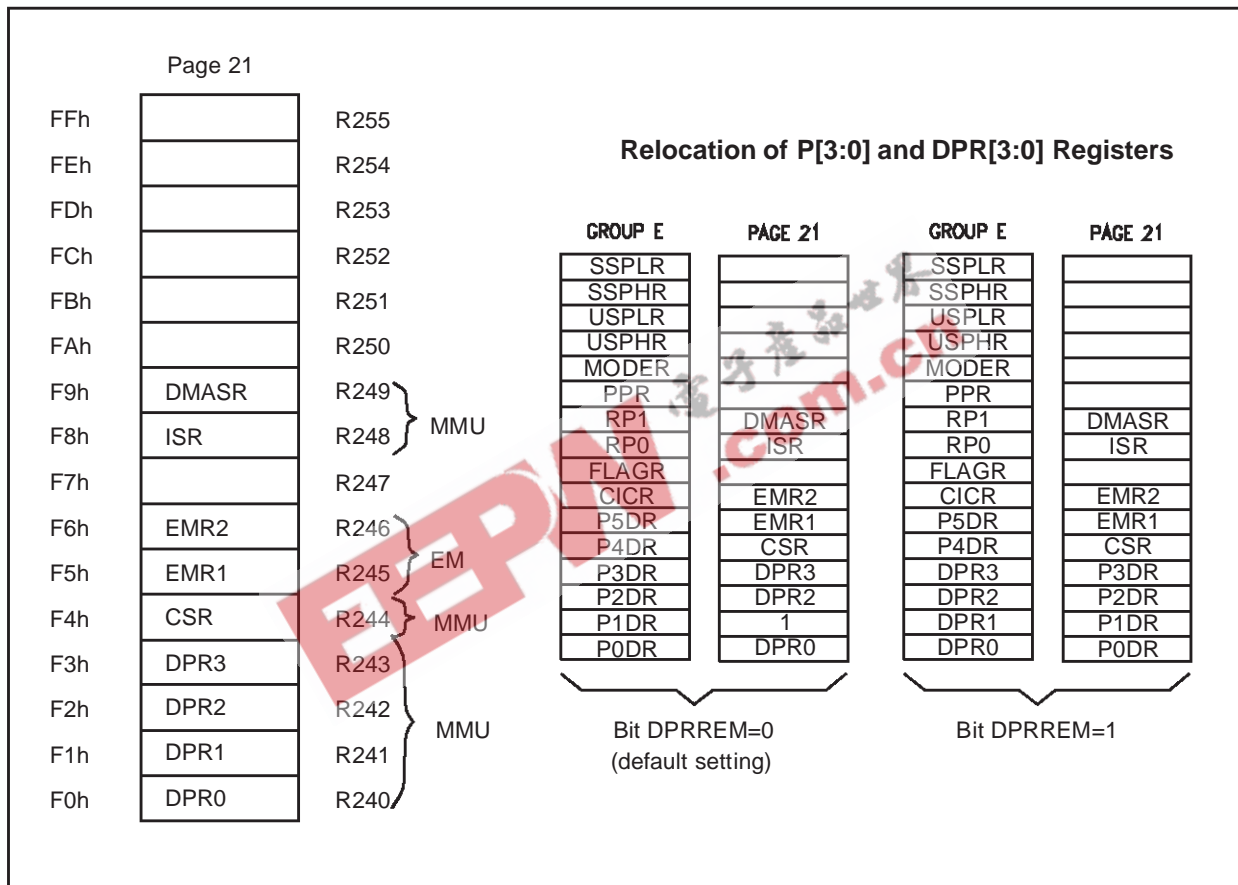

2.6 ADDRESS SPACE EXTENSION

To manage 4 Mbytes of addressing space it is necessary to have 22 address bits. The MMU adds 6 bits to the usual 16-bit address, thus translating a 16-bit virtual address into a 22-bit physical address. There are 2 different ways to do this depending on the memory involved and on the operation being performed.

2.6.1 Addressing 16-Kbyte Pages

This extension mode is implicitly used to address Data memory space if no DMA is being performed.

The Data memory space is divided into 4 pages of 16 Kbytes. Each one of the four 8-bit registers (DPR[3:0], Data Page Registers) selects a different 16-Kbyte page. The DPR registers allow access to the entire memory space which contains 256 pages of 16 Kbytes.

Data paging is performed by extending the 14 LSB of the 16-bit address with the contents of a DPR register. The two MSBs of the 16-bit address are interpreted as the identification number of the DPR register to be used. Therefore, the DPR registers

are involved in the following virtual address ranges:

- DPR0: from 0000h to 3FFFh;
- DPR1: from 4000h to 7FFFh;
- DPR2: from 8000h to BFFFh;
- DPR3: from C000h to FFFFh.

The contents of the selected DPR register specify one of the 256 possible data memory pages. This 8-bit data page number, in addition to the remaining 14-bit page offset address forms the physical 22-bit address (see Figure 10).

A DPR register cannot be modified via an addressing mode that uses the same DPR register. For instance, the instruction “POPW DPR0” is legal only if the stack is kept either in the register file or in a memory location above 8000h, where DPR2 and DPR3 are used. Otherwise, since DPR0 and DPR1 are modified by the instruction, unpredictable behaviour could result.

Figure 16. Addressing via DPR[3:0]

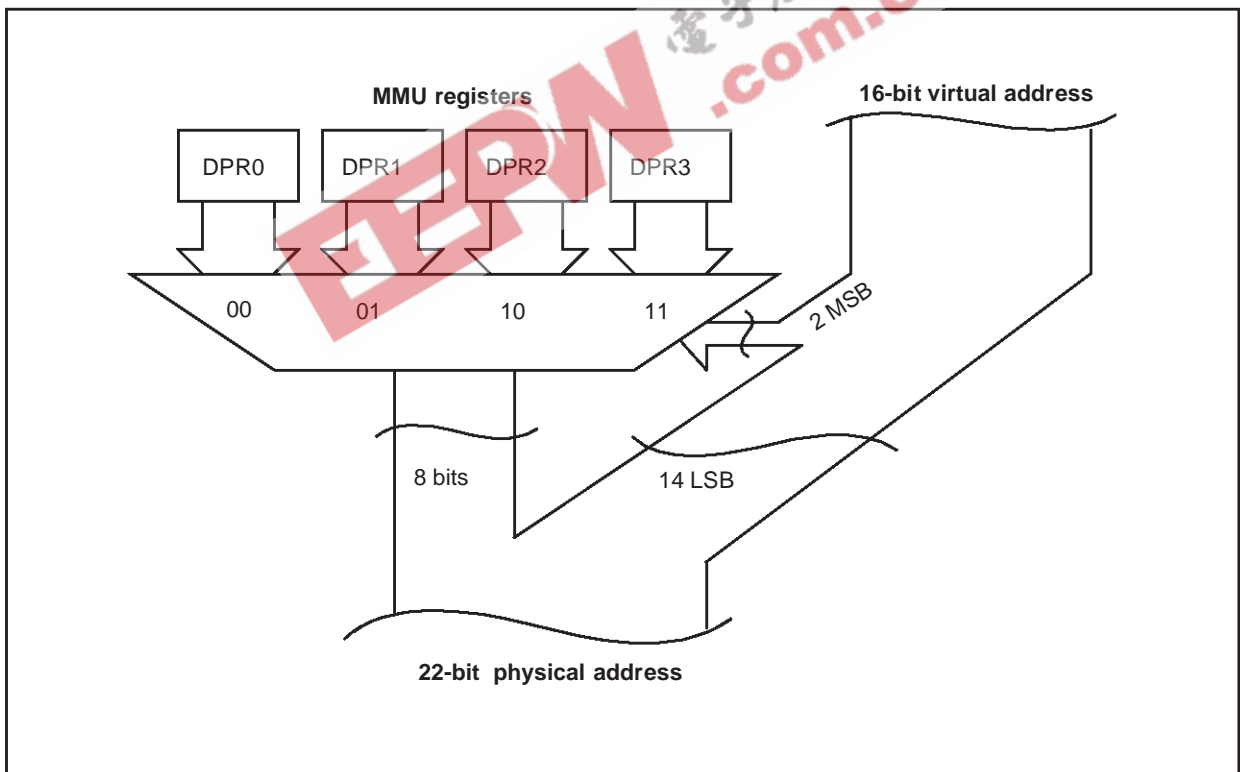

ADDRESS SPACE EXTENSION (Cont'd)

2.6.2 Addressing 64-Kbyte Segments

This extension mode is used to address Data memory space during a DMA and Program memory space during any code execution (normal code and interrupt routines).

Three registers are used: CSR, ISR, and DMASR. The 6-bit contents of one of the registers CSR, ISR, or DMASR define one out of 64 Memory segments of 64 Kbytes within the 4 Mbytes address space. The register contents represent the 6 MSBs of the memory address, whereas the 16 LSBs of the address (intra-segment address) are given by the virtual 16-bit address (see Figure 11).

2.7 MMU REGISTERS

The MMU uses 7 registers mapped into Group F, Page 21 of the Register File and 2 bits of the EMR2 register.

Most of these registers do not have a default value after reset.

2.7.1 DPR[3:0]: Data Page Registers

The DPR[3:0] registers allow access to the entire 4 Mbyte memory space composed of 256 pages of 16 Kbytes.

2.7.1.1 Data Page Register Relocation

If these registers are to be used frequently, they may be relocated in register group E, by programming bit 5 of the EMR2-R246 register in page 21. If this bit is set, the DPR[3:0] registers are located at R224-227 in place of the Port 0-3 Data Registers, which are re-mapped to the default DPR's locations: R240-243 page 21.

Data Page Register relocation is illustrated in Figure 9.

Figure 17. Addressing via CSR, ISR, and DMASR

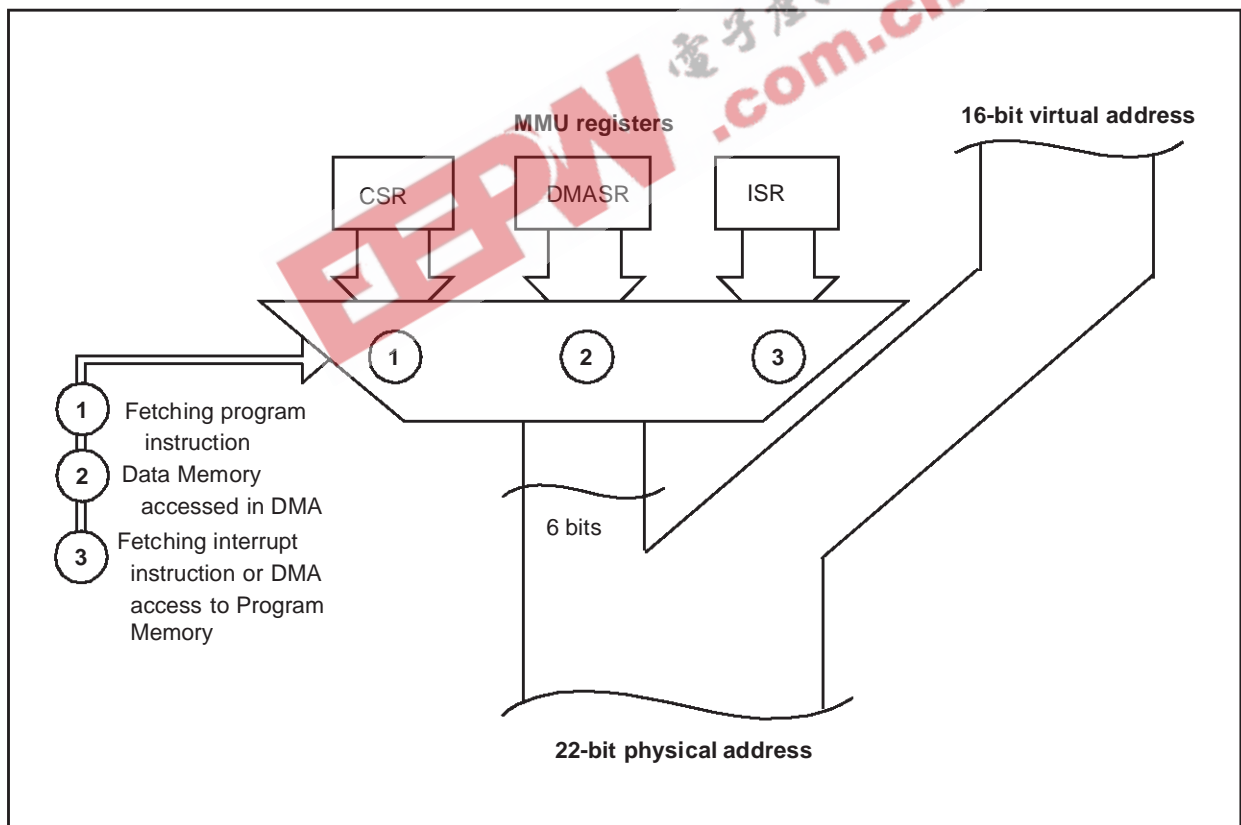

MMU REGISTERS (Cont'd)

DATA PAGE REGISTER 0 (DPR0)

R240 - Read/Write
 Register Page: 21
 Reset value: undefined

This register is relocated to R224 if EMR2.5 is set.

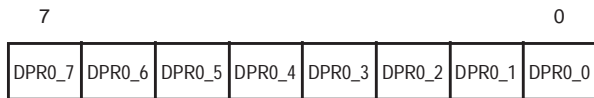

Bit 7:0 = **DPR0_[7:0]**: These bits define the 16-Kbyte Data Memory page number. They are used as the most significant address bits (A21-14) to extend the address during a Data Memory access. The DPR0 register is used when addressing the virtual address range 0000h-3FFFh.

DATA PAGE REGISTER 1 (DPR1)

R241 - Read/Write
 Register Page: 21
 Reset value: undefined

This register is relocated to R225 if EMR2.5 is set.

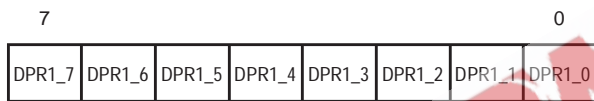

Bit 7:0 = **DPR1_[7:0]**: These bits define the 16-Kbyte Data Memory page number. They are used as the most significant address bits (A21-14) to extend the address during a Data Memory access. The DPR1 register is used when addressing the virtual address range 4000h-7FFFh.

DATA PAGE REGISTER 2 (DPR2)

R242 - Read/Write
 Register Page: 21
 Reset value: undefined

This register is relocated to R226 if EMR2.5 is set.

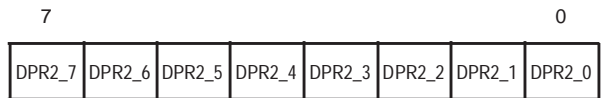

Bit 7:0 = **DPR2_[7:0]**: These bits define the 16-Kbyte Data memory page. They are used as the most significant address bits (A21-14) to extend the address during a Data memory access. The DPR2 register is involved when the virtual address is in the range 8000h-BFFFh.

DATA PAGE REGISTER 3 (DPR3)

R243 - Read/Write
 Register Page: 21
 Reset value: undefined

This register is relocated to R227 if EMR2.5 is set.

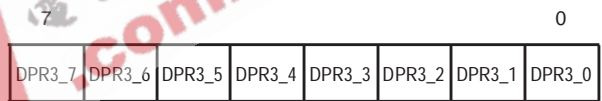

Bit 7:0 = **DPR3_[7:0]**: These bits define the 16-Kbyte Data memory page. They are used as the most significant address bits (A21-14) to extend the address during a Data memory access. The DPR3 register is involved when the virtual address is in the range C000h-FFFFh.

MMU REGISTERS (Cont'd)

2.7.2 CSR: Code Segment Register

This register selects the 64-Kbyte code segment being used at run-time to access instructions. It can also be used to access data if the *spm* instruction has been executed (or *ldpp*, *ldpd*, *lddp*). Only the 6 LSBs of the CSR register are implemented, and bits 6 and 7 are reserved. The CSR register allows access to the entire memory space, divided into 64 segments of 64 Kbytes.

To generate the 22-bit Program memory address, the contents of the CSR register is directly used as the 6 MSBs, and the 16-bit virtual address as the 16 LSBs.

Note: The CSR register should only be read and not written for data operations (there are some exceptions which are documented in the following paragraph). It is, however, modified either directly by means of the *jps* and *calls* instructions, or indirectly via the stack, by means of the *rets* instruction.

CODE SEGMENT REGISTER (CSR)

R244 - Read/Write
 Register Page: 21
 Reset value: 0000 0000 (00h)

7	0								
0	0	CSR_5	CSR_4	CSR_3	CSR_2	CSR_1	CSR_0		

Bit 7:6 = Reserved, keep in reset state.

Bit 5:0 = **CSR [5:0]**: These bits define the 64-Kbyte memory segment (among 64) which contains the code being executed. These bits are used as the most significant address bits (A21-16).

2.7.3 ISR: Interrupt Segment Register

INTERRUPT SEGMENT REGISTER (ISR)

R248 - Read/Write
 Register Page: 21
 Reset value: undefined

7	0								
0	0	ISR_5	ISR_4	ISR_3	ISR_2	ISR_1	ISR_0		

ISR and ENCSR bit (EMR2 register) are also described in the chapter relating to Interrupts, please refer to this description for further details.

Bit 7:6 = Reserved, keep in reset state.

Bit 5:0 = **ISR [5:0]**: These bits define the 64-Kbyte memory segment (among 64) which contains the interrupt vector table and the code for interrupt service routines and DMA transfers (when the PS bit of the DAPR register is reset). These bits are used as the most significant address bits (A21-16). The ISR is used to extend the address space in two cases:

- Whenever an interrupt occurs: ISR points to the 64-Kbyte memory segment containing the interrupt vector table and the interrupt service routine code. See also the Interrupts chapter.
- During DMA transactions between the peripheral and memory when the PS bit of the DAPR register is reset: ISR points to the 64 K-byte Memory segment that will be involved in the DMA transaction.

2.7.4 DMASR: DMA Segment Register

DMA SEGMENT REGISTER (DMASR)

R249 - Read/Write
 Register Page: 21
 Reset value: undefined

7	0								
0	0	DMA SR_5	DMA SR_4	DMA SR_3	DMA SR_2	DMA SR_1	DMA SR_0		

Bit 7:6 = Reserved, keep in reset state.

Bit 5:0 = **DMASR [5:0]**: These bits define the 64-Kbyte Memory segment (among 64) used when a DMA transaction is performed between the peripheral's data register and Memory, with the PS bit of the DAPR register set. These bits are used as the most significant address bits (A21-16). If the PS bit is reset, the ISR register is used to extend the address.

MMU REGISTERS (Cont'd)

Figure 18. Memory Addressing Scheme (example)

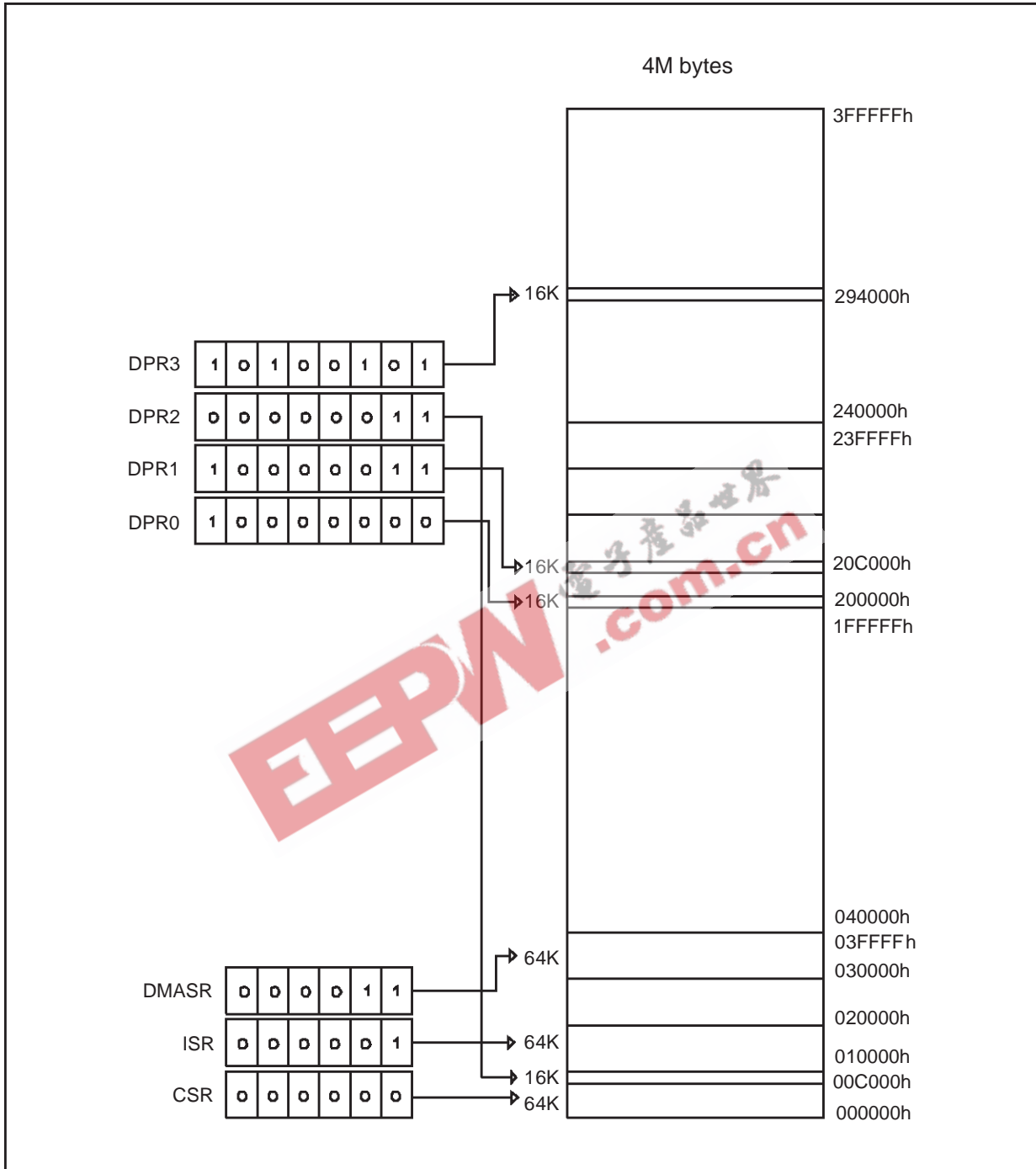

2.8 MMU USAGE

2.8.1 Normal Program Execution

Program memory is organized as a set of 64-Kbyte segments. The program can span as many segments as needed, but a procedure cannot stretch across segment boundaries. `jps`, `calls` and `rets` instructions, which automatically modify the CSR, must be used to jump across segment boundaries. Writing to the CSR is forbidden during normal program execution because it is not synchronized with the opcode fetch. This could result in fetching the first byte of an instruction from one memory segment and the second byte from another. Writing to the CSR is allowed when it is not being used, i.e. during an interrupt service routine if ENCSR is reset.

Note that a routine must always be called in the same way, i.e. either always with `call` or always with `calls`, depending on whether the routine ends with `ret` or `rets`. This means that if the routine is written without prior knowledge of the location of other routines which call it, and all the program code does not fit into a single 64-Kbyte segment, then `calls/rets` should be used.

In typical microcontroller applications, less than 64 Kbytes of RAM are used, so the four Data space pages are normally sufficient, and no change of DPR[3:0] is needed during Program execution. It may be useful however to map part of the ROM into the data space if it contains strings, tables, bit maps, etc.

If there is to be frequent use of paging, the user can set bit 5 (DPRREM) in register R246 (EMR2) of Page 21. This swaps the location of registers DPR[3:0] with that of the data registers of Ports 0-3. In this way, DPR registers can be accessed without the need to save/set/restore the Page Pointer Register. Port registers are therefore moved to page 21. Applications that require a lot of paging typically use more than 64 Kbytes of external memory, and as ports 0, 1 and 2 are required to address it, their data registers are unused.

2.8.2 Interrupts

The ISR register has been created so that the interrupt routines may be found by means of the same vector table even after a segment jump/call.

When an interrupt occurs, the CPU behaves in one of 2 ways, depending on the value of the ENCSR bit in the EMR2 register (R246 on Page 21).

If this bit is reset (default condition), the CPU works in original ST9 compatibility mode. For the duration of the interrupt service routine, the ISR is

used instead of the CSR, and the interrupt stack frame is kept exactly as in the original ST9 (only the PC and flags are pushed). This avoids the need to save the CSR on the stack in the case of an interrupt, ensuring a fast interrupt response time. The drawback is that it is not possible for an interrupt service routine to perform segment `calls/jps`: these instructions would update the CSR, which, in this case, is not used (ISR is used instead). The code size of all interrupt service routines is thus limited to 64 Kbytes.

If, instead, bit 6 of the EMR2 register is set, the ISR is used only to point to the interrupt vector table and to initialize the CSR at the beginning of the interrupt service routine: the old CSR is pushed onto the stack together with the PC and the flags, and then the CSR is loaded with the ISR. In this case, an `iret` will also restore the CSR from the stack. This approach lets interrupt service routines access the whole 4-Mbyte address space. The drawback is that the interrupt response time is slightly increased, because of the need to also save the CSR on the stack. Compatibility with the original ST9 is also lost in this case, because the interrupt stack frame is different; this difference, however, would not be noticeable for a vast majority of programs.

Data memory mapping is independent of the value of bit 6 of the EMR2 register, and remains the same as for normal code execution: the stack is the same as that used by the main program, as in the ST9. If the interrupt service routine needs to access additional Data memory, it must save one (or more) of the DPRs, load it with the needed memory page and restore it before completion.

2.8.3 DMA

Depending on the PS bit in the DAPR register (see DMA chapter) DMA uses either the ISR or the DMASR for memory accesses: this guarantees that a DMA will always find its memory segment(s), no matter what segment changes the application has performed. Unlike interrupts, DMA transactions cannot save/restore paging registers, so a dedicated segment register (DMASR) has been created. Having only one register of this kind means that all DMA accesses should be programmed in one of the two following segments: the one pointed to by the ISR (when the PS bit of the DAPR register is reset), and the one referenced by the DMASR (when the PS bit is set).

3 INTERRUPTS

3.1 INTRODUCTION

The ST9 responds to peripheral and external events through its interrupt channels. Current program execution can be suspended to allow the ST9 to execute a specific response routine when such an event occurs, providing that interrupts have been enabled, and according to a priority mechanism. If an event generates a valid interrupt request, the current program status is saved and control passes to the appropriate Interrupt Service Routine.

The ST9 CPU can receive requests from the following sources:

- On-chip peripherals
- External pins
- Top-Level Pseudo-non-maskable interrupt

According to the on-chip peripheral features, an event occurrence can generate an Interrupt request which depends on the selected mode.

Up to eight external interrupt channels, with programmable input trigger edge, are available. In addition, a dedicated interrupt channel, set to the Top-level priority, can be devoted either to the external NMI pin (where available) to provide a Non-Maskable Interrupt, or to the Timer/Watchdog. In-

errupt service routines are addressed through a vector table mapped in Memory.

Figure 19. Interrupt Response

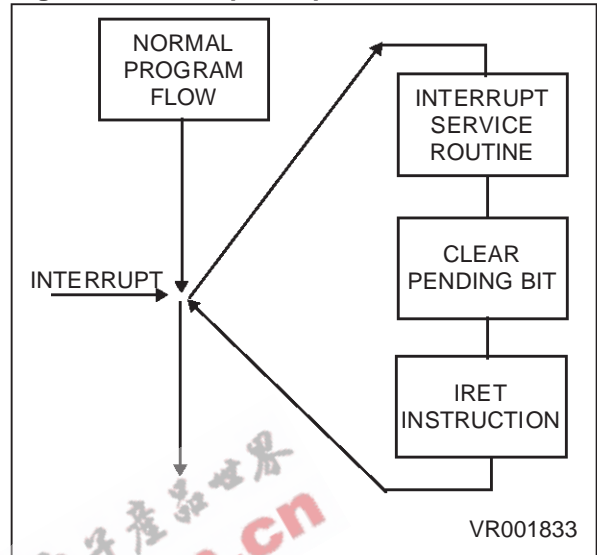

INTERRUPTS (Cont'd)

3.2 INTERRUPT VECTORING

The ST9 implements an interrupt vectoring structure which allows the on-chip peripheral to identify the location of the first instruction of the Interrupt Service Routine automatically.

When an interrupt request is acknowledged, the peripheral interrupt module provides, through its Interrupt Vector Register (IVR), a vector to point into the vector table of locations containing the start addresses of the Interrupt Service Routines (defined by the programmer).

Each peripheral has a specific IVR mapped within its Register File pages.

The Interrupt Vector table, containing the addresses of the Interrupt Service Routines, is located in the first 256 locations of Memory pointed to by the ISR register, thus allowing 8-bit vector addressing. For a description of the ISR register refer to the chapter describing the MMU.

The user Power on Reset vector is stored in the first two physical bytes in memory, 000000h and 000001h.

The Top Level Interrupt vector is located at addresses 0004h and 0005h in the segment pointed to by the Interrupt Segment Register (ISR).

With one Interrupt Vector register, it is possible to address several interrupt service routines; in fact, peripherals can share the same interrupt vector register among several interrupt channels. The most significant bits of the vector are user programmable to define the base vector address within the vector table, the least significant bits are controlled by the interrupt module, in hardware, to select the appropriate vector.

Note: The first 256 locations of the memory segment pointed to by ISR can contain program code.

3.2.1 Divide by Zero trap

The Divide by Zero trap vector is located at addresses 0002h and 0003h of each code segment; it should be noted that for each code segment a Divide by Zero service routine is required.

Warning. Although the Divide by Zero Trap operates as an interrupt, the FLAG Register is not pushed onto the system Stack automatically. As a result it must be regarded as a subroutine, and the service routine must end with the RET instruction (not IRET).

Figure 20. Interrupt Vector Table

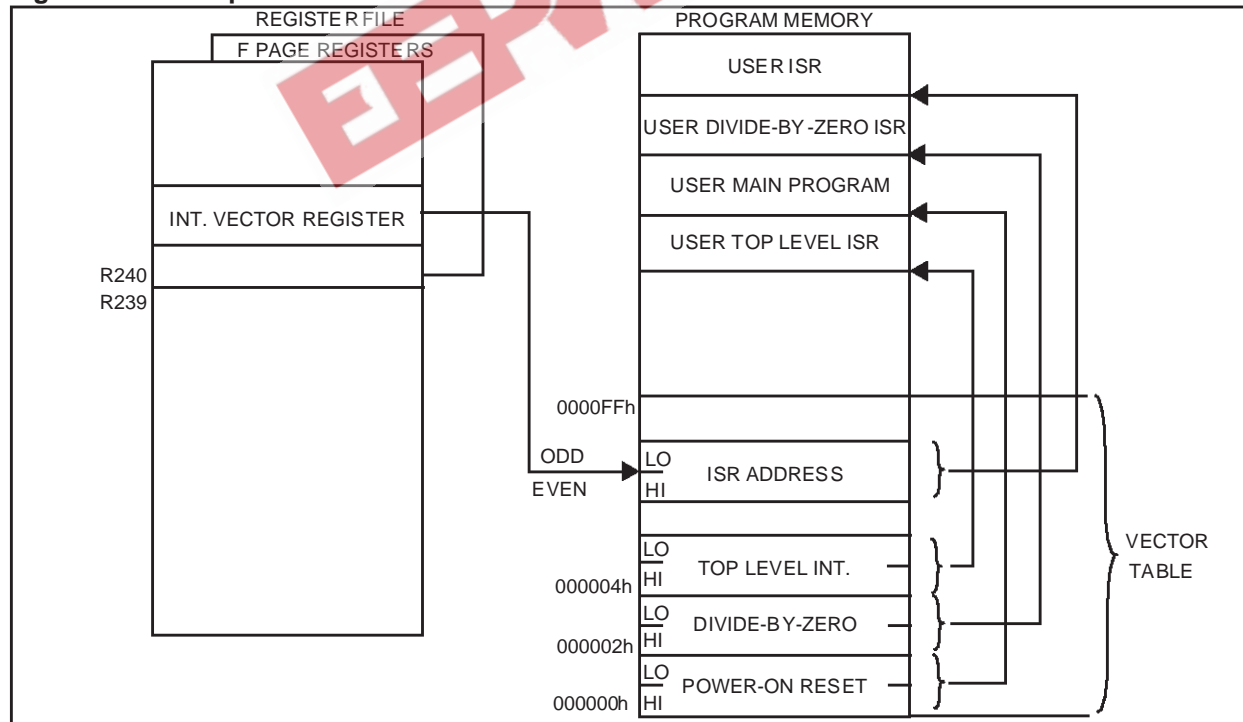

INTERRUPTS (Cont'd)

3.2.2 Segment Paging During Interrupt Routines

The ENCSR bit in the EMR2 register can be used to select between original ST9 backward compatibility mode and ST9+ interrupt management mode.

ST9 backward compatibility mode (ENCSR = 0)

If ENCSR is reset, the CPU works in original ST9 compatibility mode. For the duration of the interrupt service routine, ISR is used instead of CSR, and the interrupt stack frame is identical to that of the original ST9: only the PC and Flags are pushed.

This avoids saving the CSR on the stack in the event of an interrupt, thus ensuring a faster interrupt response time.

It is not possible for an interrupt service routine to perform inter-segment calls or jumps: these instructions would update the CSR, which, in this case, is not used (ISR is used instead). The code segment size for all interrupt service routines is thus limited to 64K bytes.

ST9+ mode (ENCSR = 1)

If ENCSR is set, ISR is only used to point to the interrupt vector table and to initialize the CSR at the beginning of the interrupt service routine: the old CSR is pushed onto the stack together with the PC and flags, and CSR is then loaded with the contents of ISR.

In this case, `iret` will also restore CSR from the stack. This approach allows interrupt service routines to access the entire 4 Mbytes of address space. The drawback is that the interrupt response time is slightly increased, because of the need to also save CSR on the stack.

Full compatibility with the original ST9 is lost in this case, because the interrupt stack frame is different.

ENCSR Bit	0	1
Mode	ST9 Compatible	ST9+
Pushed/Popped Registers	PC, FLAGR	PC, FLAGR, CSR
Max. Code Size for interrupt service routine	64KB Within 1 segment	<4 MB Across segments

3.3 INTERRUPT PRIORITY LEVELS

The ST9 supports a fully programmable interrupt priority structure. Nine priority levels are available to define the channel priority relationships:

- The on-chip peripheral channels and the eight external interrupt sources can be programmed within eight priority levels. Each channel has a 3-bit field, PRL (Priority Level), that defines its priority level in the range from 0 (highest priority) to 7 (lowest priority).
- The 9th level (Top Level Priority) is reserved for the Timer/Watchdog or the External Pseudo Non-Maskable Interrupt. An Interrupt service routine at this level cannot be interrupted in any arbitration mode. Its mask can be both maskable (TLI) or non-maskable (TLNM).

3.4 PRIORITY LEVEL ARBITRATION

The 3 bits of CPL (Current Priority Level) in the Central Interrupt Control Register contain the priority of the currently running program (CPU priority). CPL is set to 7 (lowest priority) upon reset and can be modified during program execution either by software or automatically by hardware according to the selected Arbitration Mode.

During every instruction, an arbitration phase takes place, during which, for every channel capable of generating an Interrupt, each priority level is compared to all the other requests (interrupts or DMA).

If the highest priority request is an interrupt, its PRL value must be strictly lower (that is, higher priority) than the CPL value stored in the CICR register (R230) in order to be acknowledged. The Top Level Interrupt overrides every other priority.

3.4.1 Priority level 7 (Lowest)

Interrupt requests at PRL level 7 cannot be acknowledged, as this PRL value (the lowest possible priority) cannot be strictly lower than the CPL value. This can be of use in a fully polled interrupt environment.

3.4.2 Maximum depth of nesting

No more than 8 routines can be nested. If an interrupt routine at level N is being serviced, no other Interrupts located at level N can interrupt it. This guarantees a maximum number of 8 nested levels including the Top Level Interrupt request.

3.4.3 Simultaneous Interrupts

If two or more requests occur at the same time and at the same priority level, an on-chip daisy chain, specific to every ST9 version, selects the channel

with the highest position in the chain, as shown in Table 10.

Table 10. Daisy Chain Priority

Highest Position	INTA0	INT0/WDT	
	INTA1	INT1/ADC	
	INTB0	INT2	
	INTB1	INT3	
	INTC0	INT4/	
	INTC1	INT5	
	INTD0	INT6/RCCU	
	INTD1	INT7/WKUP	
	USB		
	MFT		
	SCI		
	I2C		
	Lowest Position		

3.4.4 Dynamic Priority Level Modification

The main program and routines can be specifically prioritized. Since the CPL is represented by 3 bits in a read/write register, it is possible to modify dynamically the current priority value during program execution. This means that a critical section can have a higher priority with respect to other interrupt requests. Furthermore it is possible to prioritize even the Main Program execution by modifying the CPL during its execution. See Figure 21

Figure 21. Example of Dynamic priority level modification in Nested Mode

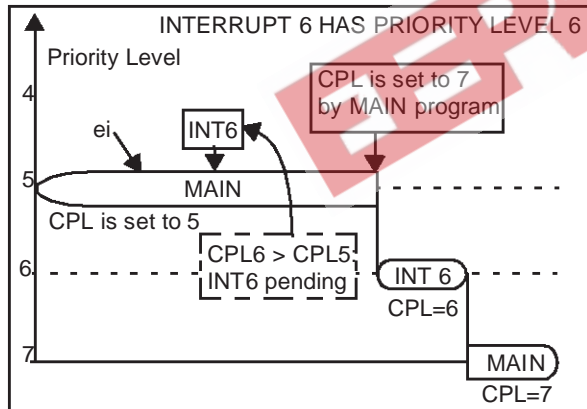

3.5 ARBITRATION MODES

The ST9 provides two interrupt arbitration modes: Concurrent mode and Nested mode. Concurrent mode is the standard interrupt arbitration mode. Nested mode improves the effective interrupt response time when service routine nesting is required, depending on the request priority levels.

The IAM control bit in the CICR Register selects Concurrent Arbitration mode or Nested Arbitration Mode.

3.5.1 Concurrent Mode

This mode is selected when the IAM bit is cleared (reset condition). The arbitration phase, performed during every instruction, selects the request with the highest priority level. The CPL value is not modified in this mode.

Start of Interrupt Routine

The interrupt cycle performs the following steps:

- All maskable interrupt requests are disabled by clearing CICR.IEN.
- The PC low byte is pushed onto system stack.
- The PC high byte is pushed onto system stack.
- If ENCSR is set, CSR is pushed onto system stack.
- The Flag register is pushed onto system stack.
- The PC is loaded with the 16-bit vector stored in the Vector Table, pointed to by the IVR.
- If ENCSR is set, CSR is loaded with ISR contents; otherwise ISR is used in place of CSR until `iret` instruction.

End of Interrupt Routine

The Interrupt Service Routine must be ended with the `iret` instruction. The `iret` instruction executes the following operations:

- The Flag register is popped from system stack.
- If ENCSR is set, CSR is popped from system stack.
- The PC high byte is popped from system stack.
- The PC low byte is popped from system stack.
- All unmasked Interrupts are enabled by setting the CICR.IEN bit.
- If ENCSR is reset, CSR is used instead of ISR.

Normal program execution thus resumes at the interrupted instruction. All pending interrupts remain pending until the next `ei` instruction (even if it is executed during the interrupt service routine).

Note: In Concurrent mode, the source priority level is only useful during the arbitration phase, where it is compared with all other priority levels and with the CPL. No trace is kept of its value during the ISR. If other requests are issued during the interrupt service routine, once the global CICR.IEN is re-enabled, they will be acknowledged regardless of the interrupt service routine's priority. This may cause undesirable interrupt response sequences.

ARBITRATION MODES (Cont'd)

Examples

In the following two examples, three interrupt requests with different priority levels (2, 3 & 4) occur simultaneously during the interrupt 5 service routine.

Example 1

In the first example, (simplest case, Figure 22) the *ei* instruction is not used within the interrupt service routines. This means that no new interrupt can be serviced in the middle of the current one. The interrupt routines will thus be serviced one after another, in the order of their priority, until the main program eventually resumes.

Figure 22. Simple Example of a Sequence of Interrupt Requests with:
 - Concurrent mode selected and
 - IEN unchanged by the interrupt routines

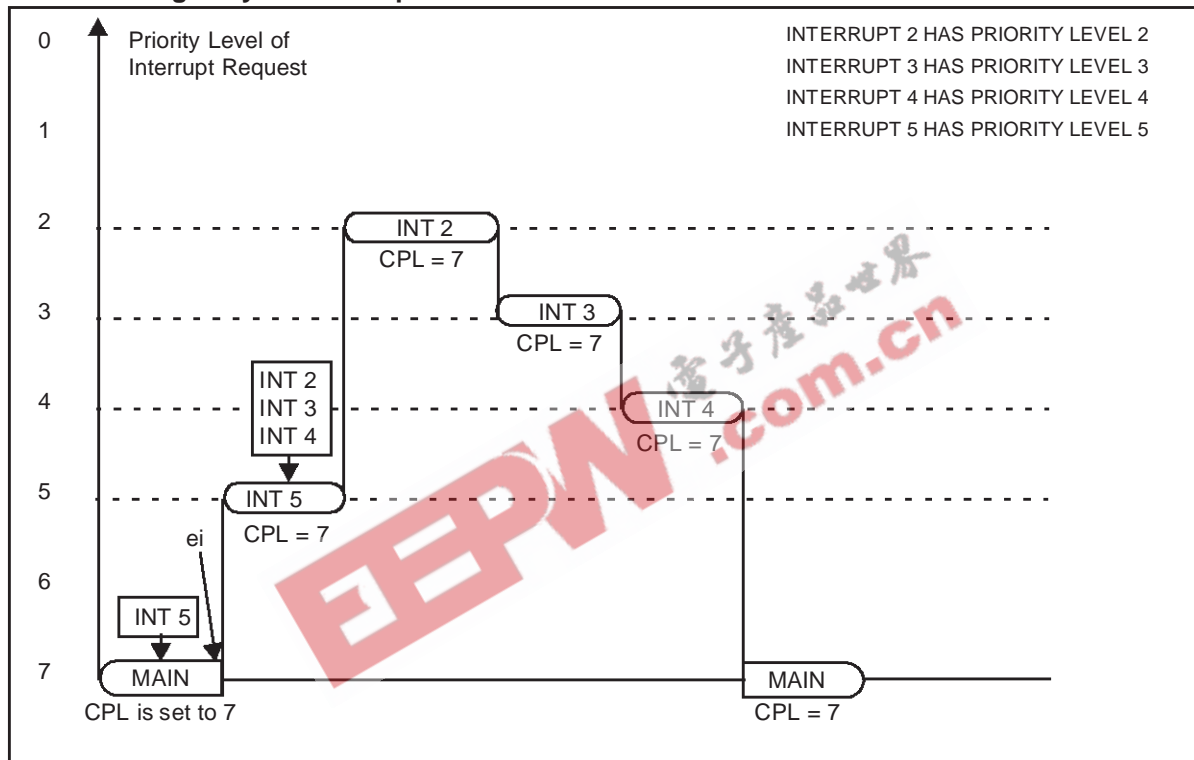

ARBITRATION MODES (Cont'd)

Example 2

In the second example, (more complex, Figure 23), each interrupt service routine sets Interrupt Enable with the `ei` instruction at the beginning of the routine. Placed here, it minimizes response time for requests with a higher priority than the one being serviced.

The level 2 interrupt routine (with the highest priority) will be acknowledged first, then, when the `ei` instruction is executed, it will be interrupted by the level 3 interrupt routine, which itself will be interrupted by the level 4 interrupt routine. When the level 4 interrupt routine is completed, the level 3 interrupt routine resumes and finally the level 2 interrupt routine. This results in the three interrupt serv-

ice routines being executed in the opposite order of their priority.

It is therefore recommended to avoid inserting the `ei` instruction in the interrupt service routine in Concurrent mode. Use the `ei` instruction only in nested mode.

WARNING: If, in Concurrent Mode, interrupts are nested (by executing `ei` in an interrupt service routine), make sure that either `ENCSR` is set or `CSR=ISR`, otherwise the `iret` of the innermost interrupt will make the CPU use `CSR` instead of `ISR` before the outermost interrupt service routine is terminated, thus making the outermost routine fail.

Figure 23. Complex Example of a Sequence of Interrupt Requests with:
 - Concurrent mode selected
 - IEN set to 1 during interrupt service routine execution

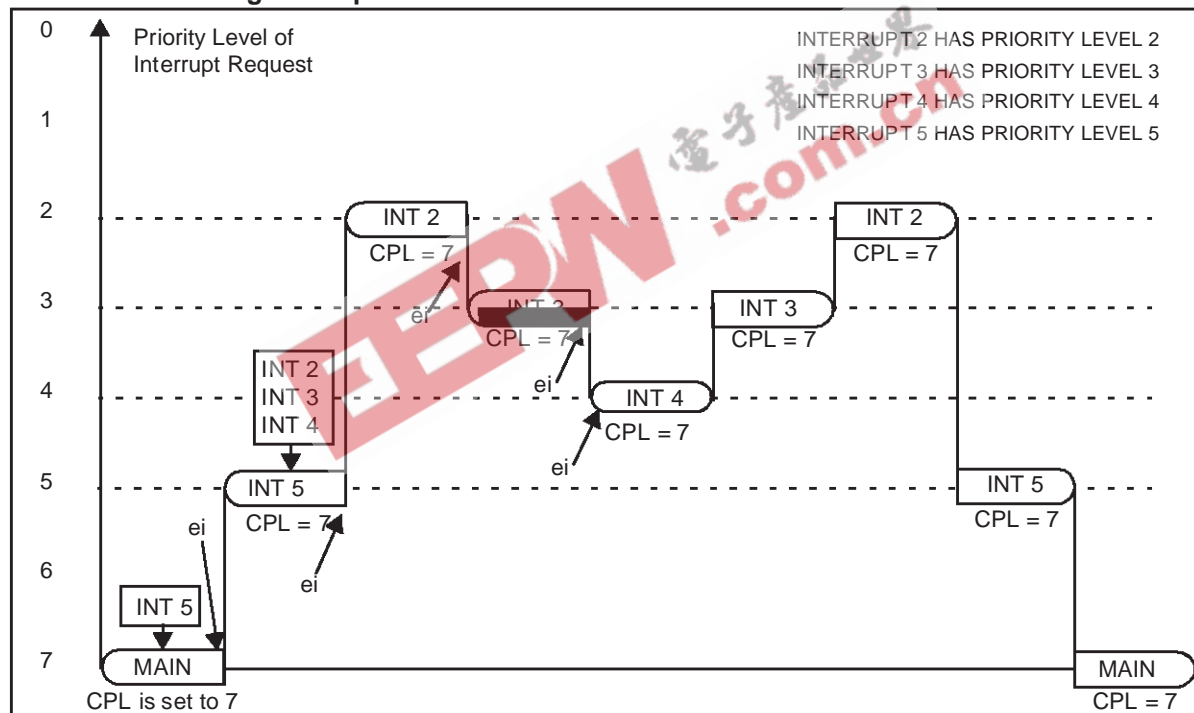

ARBITRATION MODES (Cont'd)

3.5.2 Nested Mode

The difference between Nested mode and Concurrent mode, lies in the modification of the Current Priority Level (CPL) during interrupt processing.

The arbitration phase is basically identical to Concurrent mode, however, once the request is acknowledged, the CPL is saved in the Nested Interrupt Control Register (NICR) by setting the NICR bit corresponding to the CPL value (i.e. if the CPL is 3, the bit 3 will be set).

The CPL is then loaded with the priority of the request just acknowledged; the next arbitration cycle is thus performed with reference to the priority of the interrupt service routine currently being executed.

Start of Interrupt Routine

The interrupt cycle performs the following steps:

- All maskable interrupt requests are disabled by clearing CICR.IEN.
- CPL is saved in the special NICR stack to hold the priority level of the suspended routine.
- Priority level of the acknowledged routine is stored in CPL, so that the next request priority will be compared with the one of the routine currently being serviced.
- The PC low byte is pushed onto system stack.
- The PC high byte is pushed onto system stack.
- If ENCSR is set, CSR is pushed onto system stack.
- The Flag register is pushed onto system stack.
- The PC is loaded with the 16-bit vector stored in the Vector Table, pointed to by the IVR.
- If ENCSR is set, CSR is loaded with ISR contents; otherwise ISR is used in place of CSR until `iret` instruction.

Figure 24. Simple Example of a Sequence of Interrupt Requests with:
 - Nested mode
 - IEN unchanged by the interrupt routines

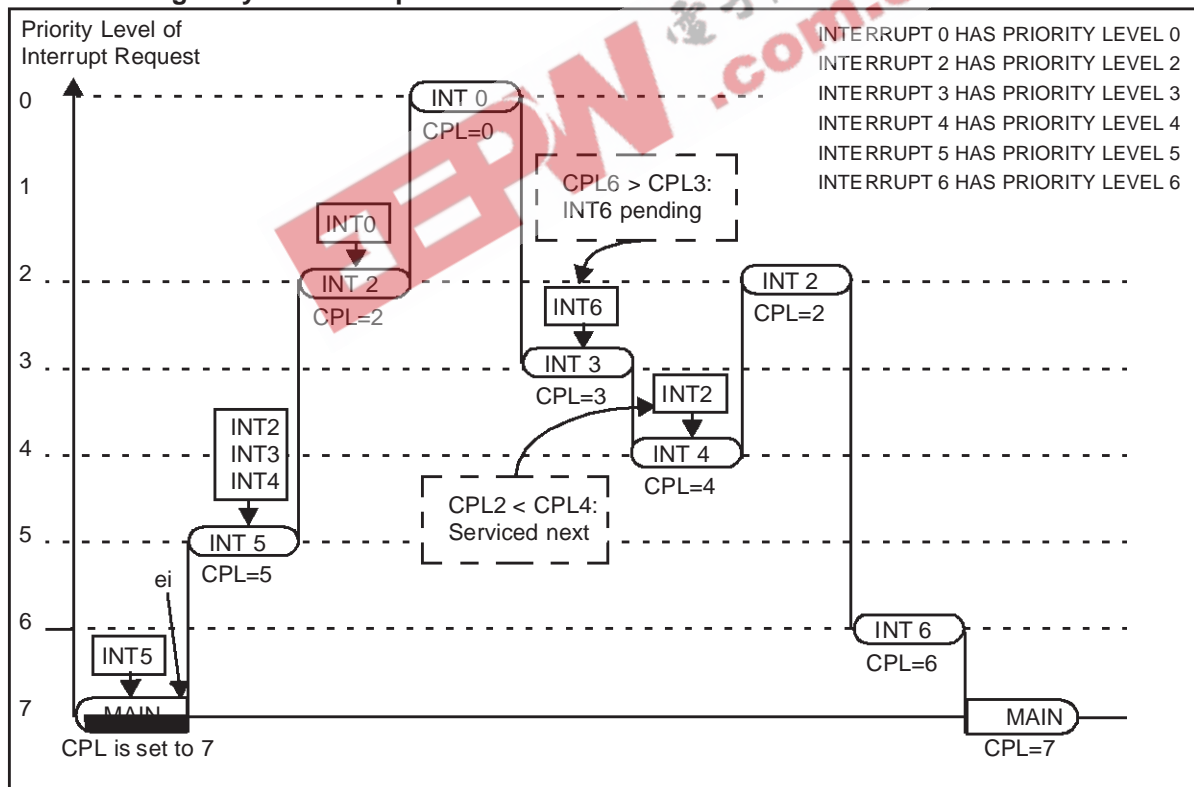

ARBITRATION MODES (Cont'd)

End of Interrupt Routine

The `iret` Interrupt Return instruction executes the following steps:

- The Flag register is popped from system stack.
- If `ENCSR` is set, `CSR` is popped from system stack.
- The PC high byte is popped from system stack.
- The PC low byte is popped from system stack.
- All unmasked Interrupts are enabled by setting the `CICR.IEN` bit.
- The priority level of the interrupted routine is popped from the special register (`NICR`) and copied into `CPL`.

- If `ENCSR` is reset, `CSR` is used instead of `ISR`, unless the program returns to another nested routine.

The suspended routine thus resumes at the interrupted instruction.

Figure 24 contains a simple example, showing that if the `ei` instruction is not used in the interrupt service routines, nested and concurrent modes are equivalent.

Figure 25 contains a more complex example showing how nested mode allows nested interrupt processing (enabled inside the interrupt service routines using the `ei` instruction) according to their priority level.

**Figure 25. Complex Example of a Sequence of Interrupt Requests with:
- Nested mode
- IEN set to 1 during the interrupt routine execution**

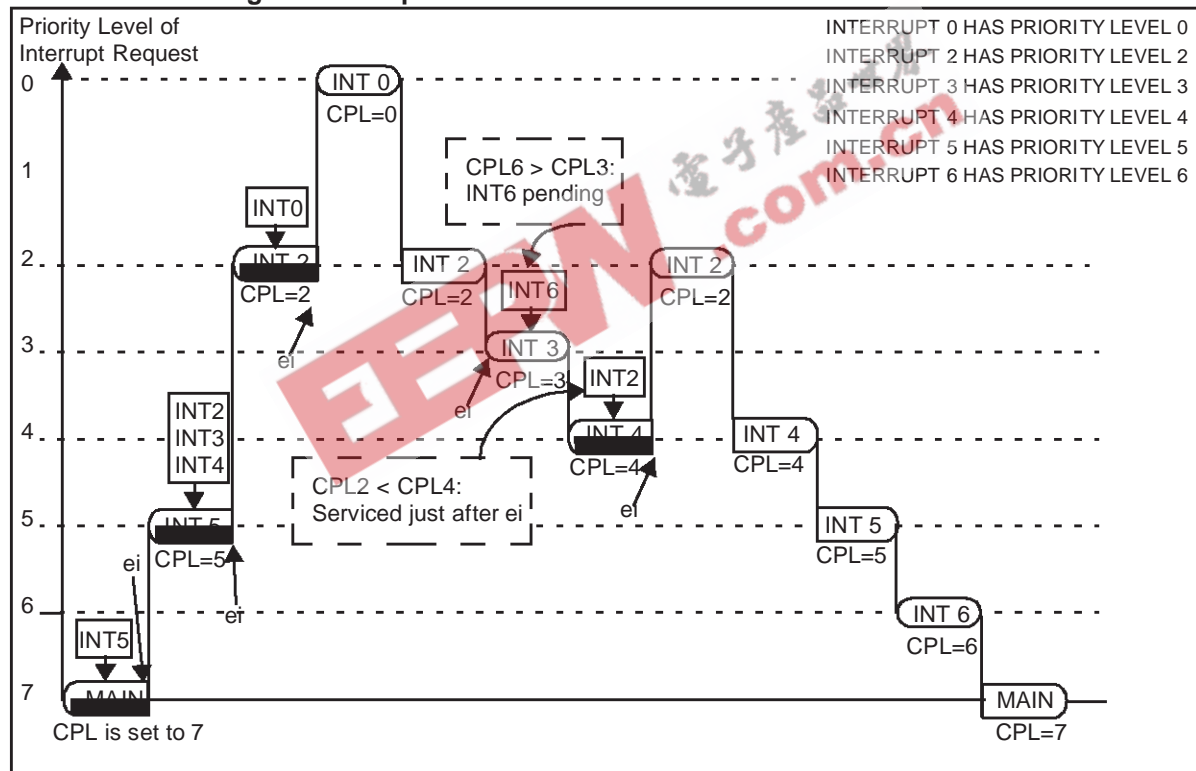

3.6 EXTERNAL INTERRUPTS

The standard ST9 core contains 8 external interrupts sources grouped into four pairs.

INT7 is connected to 8 different I/O pins of Port 3. Once these pins are programmed as alternate function they are able to generate an interrupt.

Table 11. External Interrupt Channel Grouping

External Interrupt	Channel
INT7	INTD1
INT6	INTD0
INT5	INTC1
INT4	INTC0
INT3	INTB1
INT2	INTB0
INT1	INTA1
INT0	INTA0

INT0 .. 6 have a trigger control bit TEA0,..TED1 (R242,EITR.0,..,7 Page 0) to select triggering on the rising or falling edge of the external pin. If the Trigger control bit is set to "1", the corresponding pending bit IPA0,..,IPD1 (R243, EIPR.0,..,6 Page 0) is set on the input pin rising edge, if it is cleared, the pending bit is set on the falling edge of the input pin. Each source can be individually masked through the corresponding control bit IMA0,..,IMD1 (EIMR.6,..,0). See Figure 27.

INT7 is falling edge sensitive only, bit EIMR.7 must always be cleared.

The priority level of the external interrupt sources can be programmed among the eight priority levels with the control register EIPLR (R245). The priority level of each pair is software defined using the bits PRL2, PRL1. For each pair, the even channel (A0,B0,C0,D0) of the group has the even priority level and the odd channel (A1,B1,C1,D1) has the odd (lower) priority level.

Figure 26. Priority Level Examples

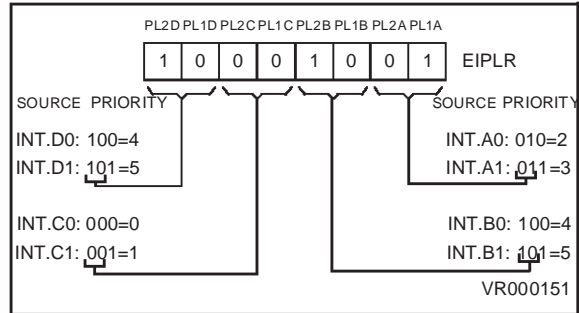

Figure 26 shows an example of priority levels.

Figure 27 gives an overview of the External interrupt control bits and vectors.

- The source of the interrupt channel A0 can be selected between the external pin INTO (when IAOS = "1", the reset value) or the On-chip Timer/Watchdog peripheral (when IAOS = "0").
- The source of the interrupt channel A1 can be selected between the external pin INT1 (when AD-INT="0") or the on-chip ADC peripheral (when AD-INT="1", the reset value).
- The source of the interrupt channel D0 can be selected between the external pin INT6 (when INT_SEL = "0") or the on-chip RCCU.

Warning: When using channels shared by both external interrupts and peripherals, special care must be taken to configure their control registers for both peripherals and interrupts.

Table 12. Multiplexed Interrupt Sources

Channel	Internal Interrupt Source	External Interrupt Source
INTA0	Timer/Watchdog	INT0
INTA1	ADC	INT1
INTD0	RCCU	INT6

EXTERNAL INTERRUPTS (Cont'd)

Figure 27. External Interrupts Control Bits and Vectors

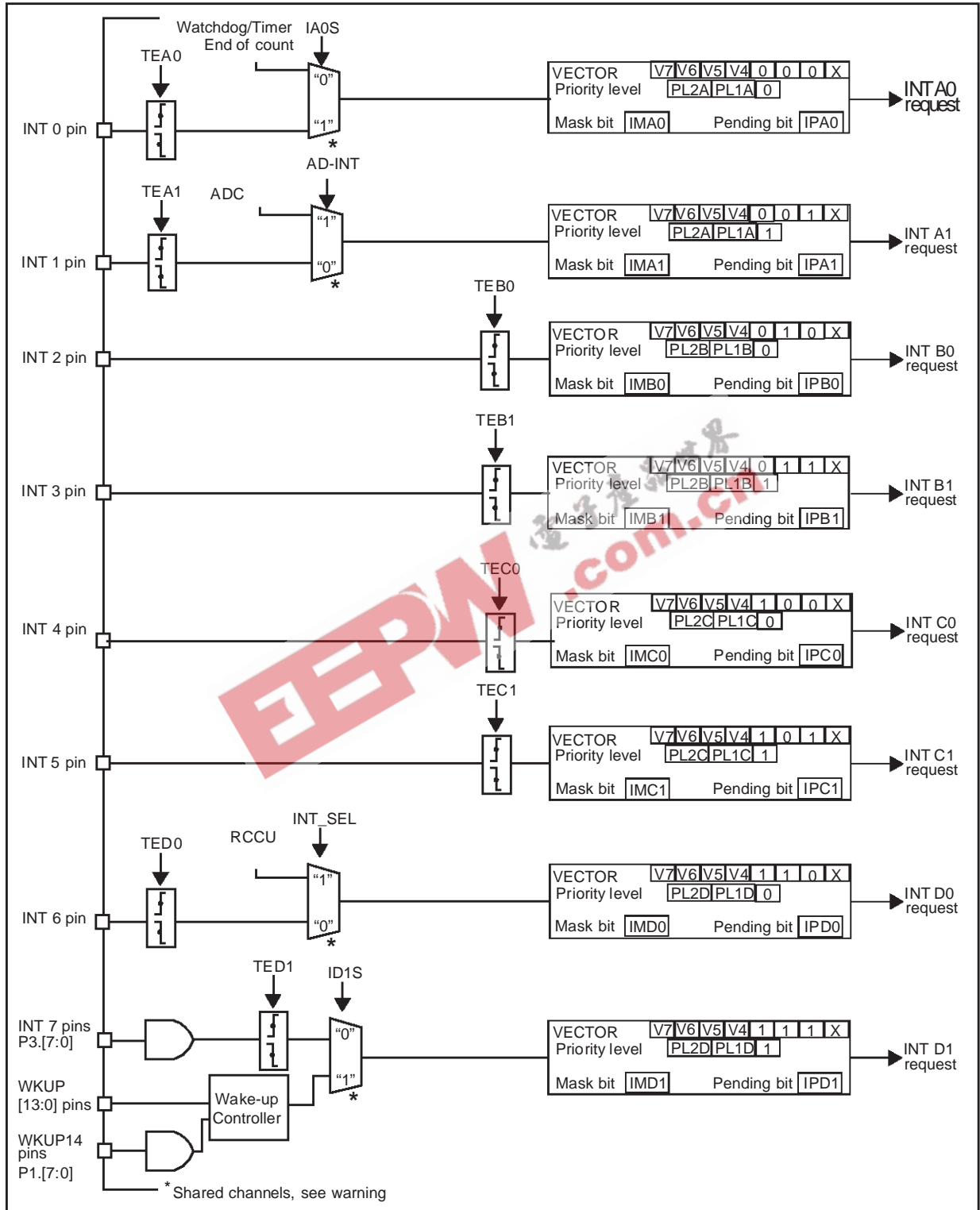

3.7 MANAGEMENT OF WAKE-UP LINES AND EXTERNAL INTERRUPT LINES

In the ST92163, fifteen Wake-up lines (WKUP[14:0]) are available on external pins. The WKUP[15] line is internally connected to the USB interfaceline.

Figure 28 shows the connections of the External Interrupt Lines INT7[7:0] and the Wake-up/Interrupt Lines managed through the WUIMU on the INTD1 interrupt channel.

Figure 28. Wake-Up Lines and External Interrupt Lines Management

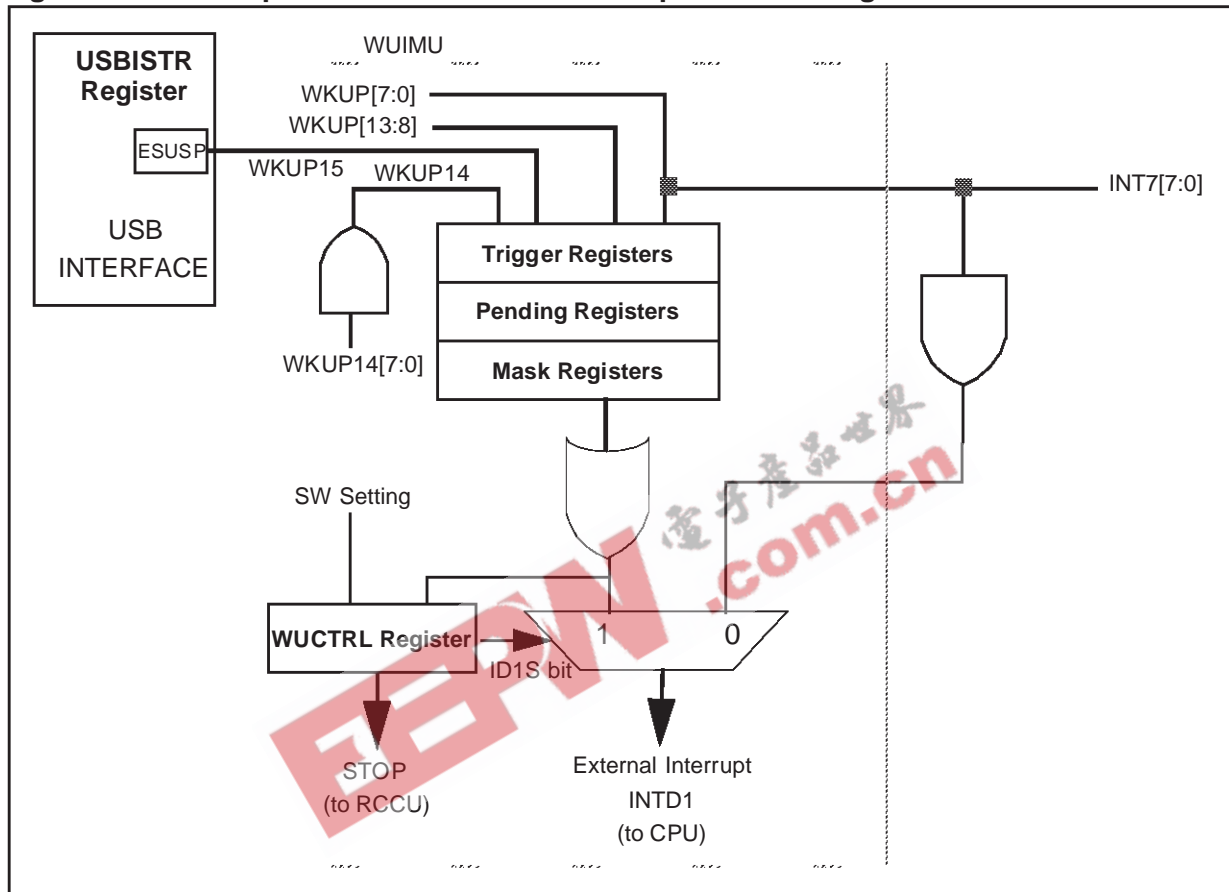

3.8 TOP LEVEL INTERRUPT

The Top Level Interrupt channel can be assigned either to the external pin NMI or to the Timer/ Watchdog according to the status of the control bit EIVR.TLIS (R246.2, Page 0). If this bit is high (the reset condition) the source is the external pin NMI. If it is low, the source is the Timer/ Watchdog End Of Count. When the source is the NMI external pin, the control bit EIVR.TLTEV (R246.3; Page 0) selects between the rising (if set) or falling (if reset) edge generating the interrupt request. When the selected event occurs, the CICR.TLIP bit (R230.6) is set. Depending on the mask situation, a Top Level Interrupt request may be generated. Two kinds of masks are available, a Maskable mask and a Non-Maskable mask. The first mask is the CICR.TLI bit (R230.5): it can be set or cleared to enable or disable respectively the Top Level Interrupt request. If it is enabled, the global Enable Interrupt bit, CICR.IEN (R230.4; Page 0) must also be enabled in order to allow a Top Level Request.

The second mask NICR.TLNM (R247.7; Page 0) is a set-only mask. Once set, it enables the Top Level Interrupt request independently of the value of CICR.IEN and it cannot be cleared by the program. Only the processor RESET cycle can clear this bit. This does not prevent the user from ignoring some sources due to a change in TLIS.

The Top Level Interrupt Service Routine cannot be interrupted by any other interrupt or DMA request, in any arbitration mode, not even by a subsequent Top Level Interrupt request.

Warning. The interrupt machine cycle of the Top Level Interrupt does not clear the CICR.IEN bit, and the corresponding `iret` does not set it.

3.9 ON-CHIP PERIPHERAL INTERRUPTS

The general structure of the peripheral interrupt unit is described here, however each on-chip peripheral has its own specific interrupt unit containing one or more interrupt channels, or DMA channels. Please refer to the specific peripheral chapter for the description of its interrupt features and control registers.

The on-chip peripheral interrupt channels provide the following control bits:

- **Interrupt Pending bit (IP).** Set by hardware when the Trigger Event occurs. Can be set/cleared by software to generate/cancel pending interrupts and give the status for Interrupt polling.
- **Interrupt Mask bit (IM).** If IM = "0", no interrupt request is generated. If IM = "1" an interrupt request is generated whenever IP = "1" and CICR.IEN = "1".
- **Priority Level (PRL, 3 bits).** These bits define the current priority level, PRL=0: the highest priority, PRL=7: the lowest priority (the interrupt cannot be acknowledged)
- **Interrupt Vector Register (IVR, up to 7 bits).** The IVR points to the vector table which itself contains the interrupt routine start address.

Figure 29. Top Level Interrupt Structure

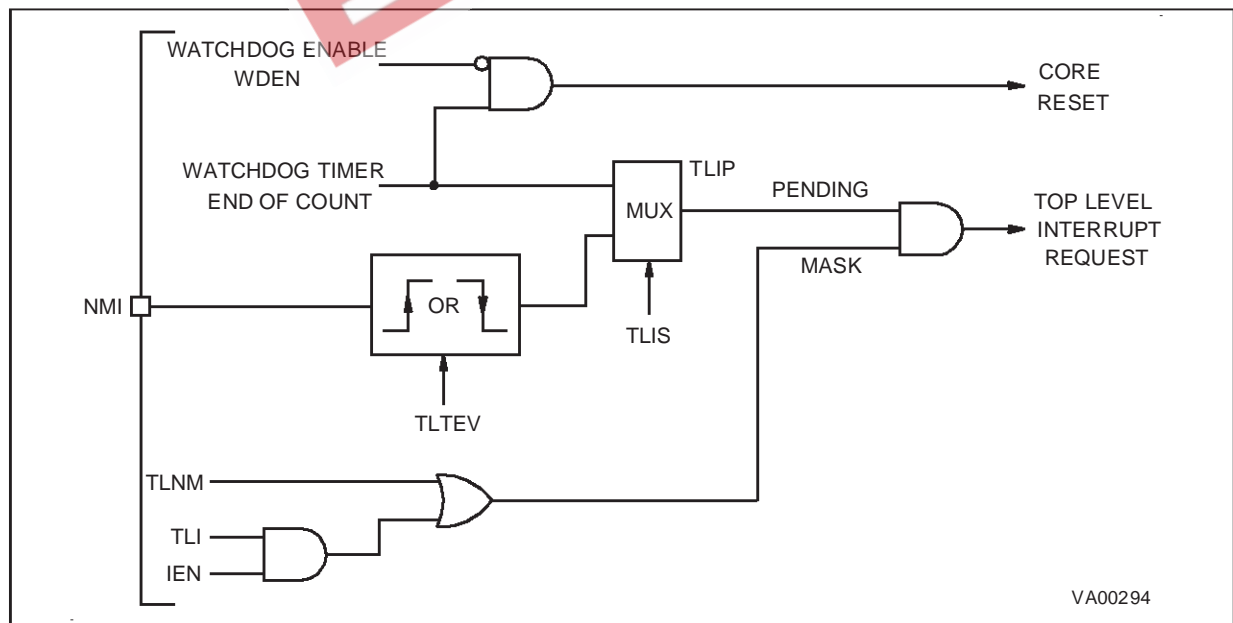

3.10 INTERRUPT RESPONSE TIME

The interrupt arbitration protocol functions completely asynchronously from instruction flow, and requires 6 CPUCLK cycles to resolve the request's priority.

Requests are sampled every 5 CPUCLK cycles.

If the interrupt request comes from an external pin, the trigger event must occur a minimum of one INTCLK cycle before the sampling time.

When an arbitration results in an interrupt request being generated, the interrupt logic checks if the current instruction (which could be at any stage of execution) can be safely aborted; if this is the case, instruction execution is terminated immediately and the interrupt request is serviced; if not, the CPU waits until the current instruction is terminated and then services the request. Instruction execution can normally be aborted provided no write operation has been performed.

For an interrupt deriving from an external interrupt channel, the response time between a user event and the start of the interrupt service routine can range from a minimum of 26 clock cycles to a maximum of 48 clock cycles.

For a non-maskable Top Level interrupt, the response time between a user event and the start of the interrupt service routine can range from a minimum of 22 clock cycles to a maximum of 48 clock cycles.

In order to guarantee edge detection, input signals must be kept low/high for a minimum of one INTCLK cycle.

An interrupt machine cycle requires a basic 18 internal clock cycles (CPUCLK), to which must be added a further 2 clock cycles if the stack is in the Register File. 2 more clock cycles must further be added if the CSR is pushed (ENCSR =1).

The interrupt machine cycle duration forms part of the two examples of interrupt response time previously quoted; it includes the time required to push values on the stack, as well as interrupt vector handling.

In Wait for Interrupt mode, a further cycle is required as wake-up delay.

EEPW.com.cn
电子產品世界

3.11 INTERRUPT REGISTERS

CENTRAL INTERRUPT CONTROL REGISTER (CICR)

R230 - Read/Write

Register Page: System

Reset value: 1000 0111 (87h)

7							0
GCEN	TLIP	TLI	IEN	IAM	CPL2	CPL1	CPL0

Bit 7 = **GCEN**: *Global Counter Enable*.
This bit enables the 16-bit Multifunction Timer peripheral.

0: MFT disabled
1: MFT enabled

Bit 6 = **TLIP**: *Top Level Interrupt Pending*.
This bit is set by hardware when Top Level Interrupt (TLI) trigger event occurs. It is cleared by hardware when a TLI is acknowledged. It can also be set by software to implement a software TLI.

0: No TLI pending
1: TLI pending

Bit 5 = **TLI**: *Top Level Interrupt*.
This bit is set and cleared by software.

0: Generate a Top Level Interrupt only if TLNM=1
1: Generate a Top Level Interrupt request when the IEN and TLIP bits=1.

Bit 4 = **IEN**: *Interrupt Enable*.
This bit is cleared by the interrupt machine cycle (except for a TLI).
It is set by the `iret` instruction (except for a return from TLI).
It is set by the `EI` instruction.
It is cleared by the `DI` instruction.

0: Maskable interrupts disabled
1: Maskable Interrupts enabled

Note: The IEN bit can also be changed by software using any instruction that operates on register CICR, however in this case, take care to avoid spurious interrupts, since IEN cannot be cleared in the middle of an interrupt arbitration. Only modify the IEN bit when interrupts are disabled or when no peripheral can generate interrupts. For exam-

ple, if the state of IEN is not known in advance, and its value must be restored from a previous push of CICR on the stack, use the sequence `DI ; POP CICR` to make sure that no interrupts are being arbitrated when CICR is modified.

Bit 3 = **IAM**: *Interrupt Arbitration Mode*.
This bit is set and cleared by software.

0: Concurrent Mode
1: Nested Mode

Bit 2:0 = **CPL[2:0]**: *Current Priority Level*.
These bits define the Current Priority Level. CPL=0 is the highest priority. CPL=7 is the lowest priority. These bits may be modified directly by the interrupt hardware when Nested Interrupt Mode is used.

EXTERNAL INTERRUPT TRIGGER REGISTER (EITR)

R242 - Read/Write

Register Page: 0

Reset value: 0000 0000 (00h)

7							0
TED1	TED0	TEC1	TEC0	TEB1	TEB0	TEA1	TEA0

Bit 7 = **TED1**: *INTD1 Trigger Event*
Must always stay cleared

Bit 6 = **TED0**: *INTD0 Trigger Event*

Bit 5 = **TEC1**: *INTC1 Trigger Event*

Bit 4 = **TEC0**: *INTC0 Trigger Event*

Bit 3 = **TEB1**: *INTB1 Trigger Event*

Bit 2 = **TEB0**: *INTB0 Trigger Event*

Bit 1 = **TEA1**: *INTA1 Trigger Event*

Bit 0 = **TEA0**: *INTA0 Trigger Event*

These bits are set and cleared by software.

0: Select falling edge as interrupt trigger event
1: Select rising edge as interrupt trigger event

INTERRUPT REGISTERS (Cont'd)

EXTERNAL INTERRUPT PENDING REGISTER (EIPR)

R243 - Read/Write
 Register Page: 0
 Reset value: 0000 0000 (00h)

7							0
IPD1	IPD0	IPC1	IPC0	IPB1	IPB0	IPA1	IPA0

- Bit 7 = **IPD1**: *INTD1 Interrupt Pending bit*
- Bit 6 = **IPD0**: *INTD0 Interrupt Pending bit*
- Bit 5 = **IPC1**: *INTC1 Interrupt Pending bit*
- Bit 4 = **IPC0**: *INTC0 Interrupt Pending bit*
- Bit 3 = **IPB1**: *INTB1 Interrupt Pending bit*
- Bit 2 = **IPB0**: *INTB0 Interrupt Pending bit*
- Bit 1 = **IPA1**: *INTA1 Interrupt Pending bit*
- Bit 0 = **IPA0**: *INTA0 Interrupt Pending bit*

These bits are set by hardware on occurrence of a trigger event (as specified in the EITR register) and are cleared by hardware on interrupt acknowledge. They can also be set by software to implement a software interrupt.
 0: No interrupt pending
 1: Interrupt pending

EXTERNAL INTERRUPT MASK-BIT REGISTER (EIMR)

R244 - Read/Write
 Register Page: 0
 Reset value: 0000 0000 (00h)

7							0
IMD1	IMD0	IMC1	IMC0	IMB1	IMB0	IMA1	IMA0

- Bit 7 = **IMD1**: *INTD1 Interrupt Mask*
- Bit 6 = **IMD0**: *INTD0 Interrupt Mask*
- Bit 5 = **IMC1**: *INTC1 Interrupt Mask*
- Bit 4 = **IMC0**: *INTC0 Interrupt Mask*

- Bit 3 = **IMB1**: *INTB1 Interrupt Mask*
- Bit 2 = **IMB0**: *INTB0 Interrupt Mask*
- Bit 1 = **IMA1**: *INTA1 Interrupt Mask*
- Bit 0 = **IMA0**: *INTA0 Interrupt Mask*

These bits are set and cleared by software.
 0: Interrupt masked
 1: Interrupt not masked (an interrupt is generated if the IPxx and IEN bits = 1)

EXTERNAL INTERRUPT PRIORITY LEVEL REGISTER (EIPLR)

R245 - Read/Write
 Register Page: 0
 Reset value: 1111 1111 (FFh)

7							0
PL2D	PL1D	PL2C	PL1C	PL2B	PL1B	PL2A	PL1A

- Bit 7:6 = **PL2D, PL1D**: *INTD0, D1 Priority Level.*
- Bit 5:4 = **PL2C, PL1C**: *INTC0, C1 Priority Level.*
- Bit 3:2 = **PL2B, PL1B**: *INTB0, B1 Priority Level.*
- Bit 1:0 = **PL2A, PL1A**: *INTA0, A1 Priority Level.*

These bits are set and cleared by software.
 The priority is a three-bit value. The LSB is fixed by hardware at 0 for Channels A0, B0, C0 and D0 and at 1 for Channels A1, B1, C1 and D1.

PL2x	PL1x	Hardware bit	Priority
0	0	0 1	0 (Highest) 1
0	1	0 1	2 3
1	0	0 1	4 5
1	1	0 1	6 7 (Lowest)

INTERRUPT REGISTERS (Cont'd)**EXTERNAL INTERRUPT VECTOR REGISTER (EIVR)**

R246 - Read/Write

Register Page: 0

Reset value: xxxx 0110 (x6h)

7							0
V7	V6	V5	V4	TLTEV	TLIS	IAOS	EWEN

Bit 7:4 = **V[7:4]**: *Most significant nibble of External Interrupt Vector.*

These bits are not initialized by reset. For a representation of how the full vector is generated from V[7:4] and the selected external interrupt channel, refer to Figure 27.

Bit 3 = **TLTEV**: *Top Level Trigger Event bit.*

This bit is set and cleared by software.

0: Select falling edge as NMI trigger event
1: Select rising edge as NMI trigger event

Bit 2 = **TLIS**: *Top Level Input Selection.*

This bit is set and cleared by software.

0: Watchdog End of Count is TL interrupt source
1: NMI is TL interrupt source

Bit 1 = **IAOS**: *Interrupt Channel A0 Selection.*

This bit is set and cleared by software.

0: Watchdog End of Count is INTA0 source
1: External Interrupt pin is INTA0 source

Bit 0 = **EWEN**: *External Wait Enable.*

This bit is set and cleared by software.

0: WAITN pin disabled

1: WAITN pin enabled (to stretch the external memory access cycle).

Note: For more details on Wait mode refer to the section describing the WAITN pin in the External Memory Chapter.

NESTED INTERRUPT CONTROL (NICR)

R247 - Read/Write

Register Page: 0

Reset value: 0000 0000 (00h)

7							0
TLNM	HL6	HL5	HL4	HL3	HL2	HL1	HL0

Bit 7 = **TLNM**: *Top Level Not Maskable.*

This bit is set by software and cleared only by a hardware reset.

0: Top Level Interrupt Maskable. A top level request is generated if the IEN, TLI and TLIP bits =1

1: Top Level Interrupt Not Maskable. A top level request is generated if the TLIP bit =1

Bit 6:0 = **HL[6:0]**: *Hold Level x*

These bits are set by hardware when, in Nested Mode, an interrupt service routine at level x is interrupted from a request with higher priority (other than the Top Level interrupt request). They are cleared by hardware at the `iret` execution when the routine at level x is recovered.

INTERRUPT REGISTERS (Cont'd)

EXTERNAL MEMORY REGISTER 2 (EMR2)

R246 - Read/Write

Register Page: 21

Reset value: 0000 1111 (0Fh)

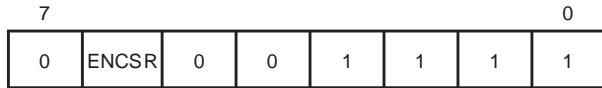

Bit 7, 5:0 = Reserved, keep in reset state. Refer to the external Memory Interface Chapter.

Bit 6 = **ENCSR**: *Enable Code Segment Register*. This bit is set and cleared by software. It affects the ST9 CPU behaviour whenever an interrupt request is issued.

0: The CPU works in original ST9 compatibility mode. For the duration of the interrupt service routine, ISR is used instead of CSR, and the interrupt stack frame is identical to that of the original ST9: only the PC and Flags are pushed. This avoids saving the CSR on the stack in the event of an interrupt, thus ensuring a faster in-

terrupt response time. The drawback is that it is not possible for an interrupt service routine to perform inter-segment calls or jumps: these instructions would update the CSR, which, in this case, is not used (ISR is used instead). The code segment size for all interrupt service routines is thus limited to 64K bytes.

1: ISR is only used to point to the interrupt vector table and to initialize the CSR at the beginning of the interrupt service routine: the old CSR is pushed onto the stack together with the PC and flags, and CSR is then loaded with the contents of ISR. In this case, `iret` will also restore the CSR from the stack. This approach allows interrupt service routines to access the entire 4 Mbytes of address space; the drawback is that the interrupt response time is slightly increased, because of the need to also save the CSR on the stack. Full compatibility with the original ST9 is lost in this case, because the interrupt stack frame is different; this difference, however, should not affect the vast majority of programs.

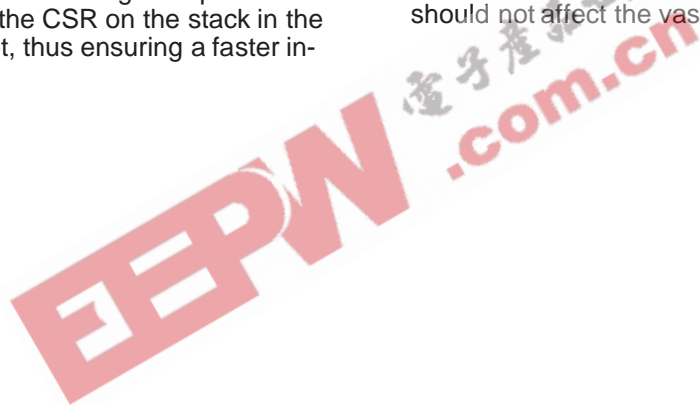

3.12 WAKE-UP / INTERRUPT LINES MANAGEMENT UNIT (WUIMU)

3.12.1 Introduction

The Wake-up/Interrupt Management Unit extends the number of external interrupt lines from 8 to 23 (depending on the number of external interrupt lines mapped on external pins of the device). It allows the source of the INTD1 external interrupt channel to be selected between the INT7 pin and up to 16 additional external Wake-up/interrupt pins.

These 16 WKUP pins can be programmed as external interrupt lines or as wake-up lines, able to exit the microcontroller from low power mode (STOP mode) (see Figure 30).

3.12.2 Main Features

- Supports up to 16 additional external wake-up or interrupt lines
- Wake-Up lines can be used to wake-up the ST9 from STOP mode.
- Programmable selection of wake-up or interrupt
- Programmable wake-up trigger edge polarity
- All Wake-Up Lines maskable

Note: The number of available pins is device dependent. Refer to the device pinout description.

Figure 30. Wake-Up Lines / Interrupt Management Unit Block Diagram

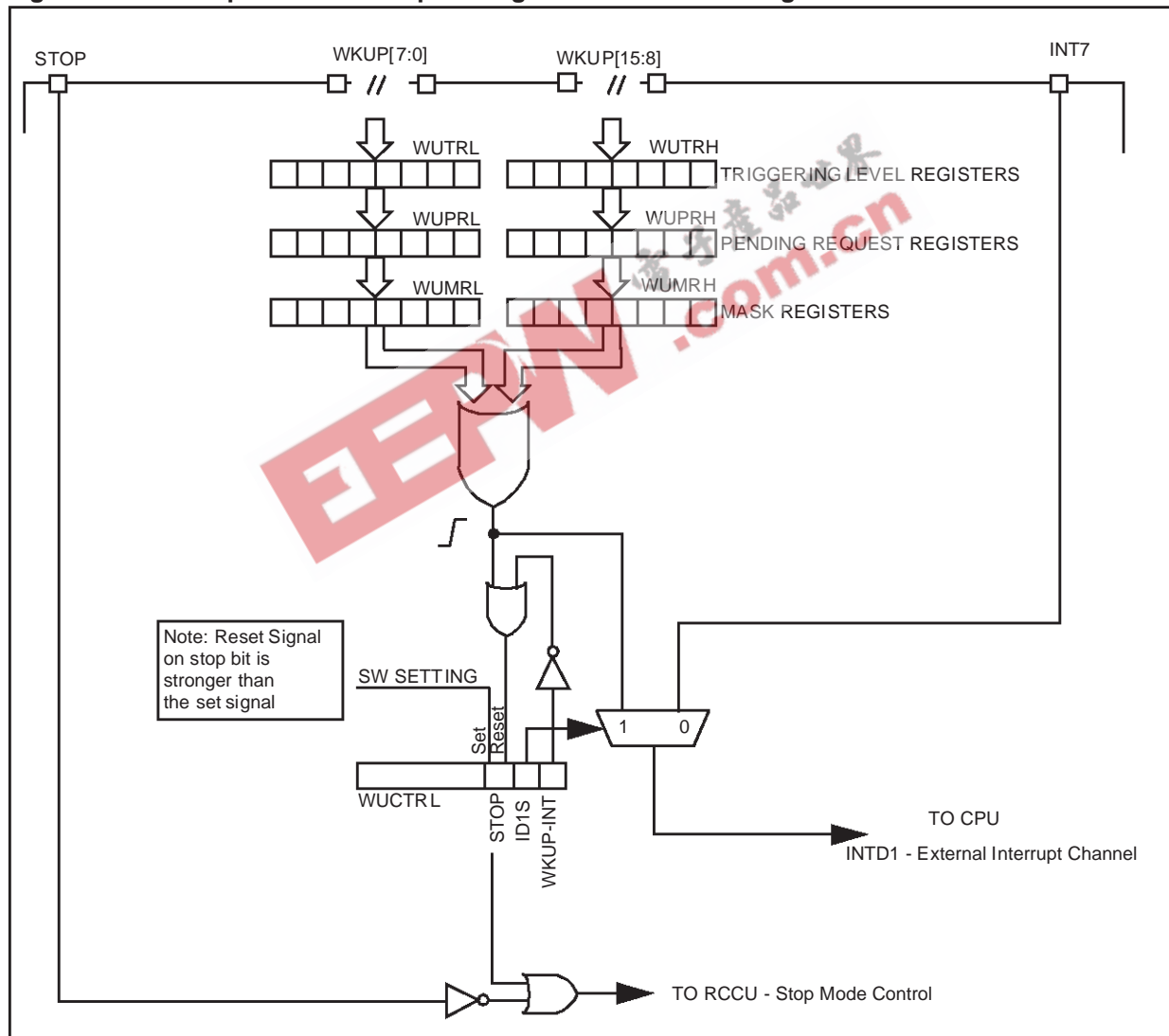

WAKE-UP / INTERRUPT LINES MANAGEMENT UNIT (Cont'd)

3.12.3 Functional Description

3.12.3.1 Interrupt Mode

To configure the 16 wake-up lines as interrupt sources, use the following procedure:

1. Configure the mask bits of the 16 wake-up lines (WUMRL, WUMRH).
2. Configure the triggering edge registers of the wake-up lines (WUTRL, WUTRH).
3. Set bit 7 of EIMR (R244 Page 0) and EITR (R242 Page 0) registers of the CPU: so an interrupt coming from one of the 16 lines can be correctly acknowledged.
4. Reset the WKUP-INT bit in the WUCTRL register to disable Wake-up Mode.
5. Set the ID1S bit in the WUCTRL register to disable the INT7 external interrupt source and enable the 16 wake-up lines as external interrupt source lines.

To return to standard mode (INT7 external interrupt source enabled and 16 wake-up lines disabled) it is sufficient to reset the ID1S bit.

3.12.3.2 Wake-up Mode Selection

To configure the 16 lines as wake-up sources, use the following procedure:

1. Configure the mask bits of the 16 wake-up lines (WUMRL, WUMRH).
2. Configure the triggering edge registers of the wake-up lines (WUTRL, WUTRH).
3. Set, as for Interrupt Mode selection, bit 7 of EIMR and EITR registers only if an interrupt routine is to be executed after a wake-up event. Otherwise, if the wake-up event only restarts the execution of the code from where it was stopped, the INTD1 interrupt channel must be masked or the external source must be selected by resetting the ID1S bit.
4. Since the RCCU can generate an interrupt request when exiting from STOP mode, take care to mask it even if the wake-up event is

only to restart code execution.

5. Set the WKUP-INT bit in the WUCTRL register to select Wake-up Mode.
6. Set the ID1S bit in the WUCTRL register to disable the INT7 external interrupt source and enable the 16 wake-up lines as external interrupt source lines. This is not mandatory if the wake-up event does not require an interrupt response.
7. Write the sequence 1,0,1 to the STOP bit of the WUCTRL register with three consecutive write operations. This is the STOP bit setting sequence.

To detect if STOP Mode was entered or not, immediately after the STOP bit setting sequence, poll the RCCU EX_STP bit (R242.7, Page 55) and the STOP bit itself.

3.12.3.3 STOP Mode Entry Conditions

Assuming the ST9 is in Run mode: during the STOP bit setting sequence the following cases may occur:

Case 1: Wrong STOP bit setting sequence

This can happen if an Interrupt/DMA request is acknowledged during the STOP bit setting sequence. In this case polling the STOP and EX_STP bits will give:

STOP = 0, EX_STP = 0

This means that the ST9 did not enter STOP mode due to a bad STOP bit setting sequence: the user must retry the sequence.

Case 2: Correct STOP bit setting sequence

In this case the ST9 enters STOP mode.

To exit STOP mode, a wake-up interrupt must be acknowledged. That implies:

STOP = 0, EX_STP = 1

This means that the ST9 entered and exited STOP mode due to an external wake-up line event.

WAKE-UP / INTERRUPT LINES MANAGEMENT UNIT (Cont'd)**Case 3: A wake-up event on the external wake-up lines occurs during the STOP bit setting sequence**

There are two possible cases:

1. Interrupt requests to the CPU are disabled: in this case the ST9 will not enter STOP mode, no interrupt service routine will be executed and the program execution continues from the instruction following the STOP bit setting sequence. The status of STOP and EX_STP bits will be again:

STOP = 0, EX_STP = 0

The application can determine why the ST9 did not enter STOP mode by polling the pending bits of the external lines (at least one must be at 1).

2. Interrupt requests to CPU are enabled: in this case the ST9 will not enter STOP mode and the interrupt service routine will be executed. The status of STOP and EX_STP bits will be again:

STOP = 0, EX_STP = 0

The interrupt service routine can determine why the ST9 did not enter STOP mode by polling the pending bits of the external lines (at least one must be at 1).

If the MCU really exits from STOP Mode, the RCCU EX_STP bit is still set and must be reset by software. Otherwise, if an Interrupt/DMA request was acknowledged during the STOP bit setting sequence, the RCCU EX_STP bit is reset. This means that the MCU has filtered the STOP Mode entry request.

The WKUP-INT bit can be used by an interrupt routine to detect and to distinguish events coming from Interrupt Mode or from Wake-up Mode, allowing the code to execute different procedures.

To exit STOP mode, it is sufficient that one of the 16 wake-up lines (not masked) generates an event: the clock restarts after the delay needed for the oscillator to restart.

Note: After exiting from STOP Mode, the software can successfully reset the pending bits (edge sensitive), even though the corresponding wake-up line is still active (high or low, depending on the Trigger Event register programming); the user must poll the external pin status to detect and distinguish a short event from a long one (for example keyboard input with keystrokes of varying length).

WAKE-UP / INTERRUPT LINES MANAGEMENT UNIT (Cont'd)

3.12.4 Programming Considerations

The following paragraphs give some guidelines for designing an application program.

3.12.4.1 Procedure for Entering/Exiting STOP mode

1. Program the polarity of the trigger event of external wake-up lines by writing registers WUTRH and WUTRL.
2. Check that at least one mask bit (registers WUMRH, WUMRL) is equal to 1 (so at least one external wake-up line is not masked).
3. Reset at least the unmasked pending bits: this allows a rising edge to be generated on the INTD1 channel when the trigger event occurs (an interrupt on channel INTD1 is recognized when a rising edge occurs).
4. Select the interrupt source of the INTD1 channel (see description of ID1S bit in the WUCTRL register) and set the WKUP-INT bit.
5. To generate an interrupt on channel INTD1, bits EITR.1 (R242.7, Page 0) and EIMR.1 (R244.7, Page 0) must be set and bit EIPR.7 must be reset. Bits 7 and 6 of register R245, Page 0 must be written with the desired priority level for interrupt channel INTD1.
6. Reset the STOP bit in register WUCTRL and the EX_STP bit in the CLK_FLAG register (R242.7, Page 55). Refer to the RCCU chapter.
7. To enter STOP mode, write the sequence 1, 0, 1 to the STOP bit in the WUCTRL register with three consecutive write operations.
8. The code to be executed just after the STOP sequence must check the status of the STOP and RCCU EX_STP bits to determine if the ST9 entered STOP mode or not (See "Wake-up Mode Selection" on page 64. for details). If the ST9 did not enter in STOP mode it is necessary to reloop the procedure from the beginning, otherwise the procedure continues from next point.

9. Poll the wake-up pending bits to determine which wake-up line caused the exit from STOP mode.

10. Clear the wake-up pending bit that was set.

3.12.4.2 Simultaneous Setting of Pending Bits

It is possible that several simultaneous events set different pending bits. In order to accept subsequent events on external wake-up/interrupt lines, it is necessary to clear at least one pending bit: this operation allows a rising edge to be generated on the INTD1 line (if there is at least one more pending bit set and not masked) and so to set EIPR.7 bit again. A further interrupt on channel INTD1 will be serviced depending on the status of bit EIMR.7. Two possible situations may arise:

1. The user chooses to reset all pending bits: no further interrupt requests will be generated on channel INTD1. In this case the user has to:
 - Reset EIMR.7 bit (to avoid generating a spurious interrupt request during the next reset operation on the WUPRH register)
 - Reset WUPRH register using a read-modify-write instruction (AND, BRES, BAND)
 - Clear the EIPR.7 bit
 - Reset the WUPRL register using a read-modify-write instruction (AND, BRES, BAND)
2. The user chooses to keep at least one pending bit active: at least one additional interrupt request will be generated on the INTD1 channel. In this case the user has to reset the desired pending bits with a read-modify-write instruction (AND, BRES, BAND). This operation will generate a rising edge on the INTD1 channel and the EIPR.7 bit will be set again. An interrupt on the INTD1 channel will be serviced depending on the status of EIMR.7 bit.

WAKE-UP / INTERRUPT LINES MANAGEMENT UNIT (Cont'd)

3.12.5 Register Description

WAKE-UP CONTROL REGISTER (WUCTRL)

R249 - Read/Write

Register Page: 57

Reset Value: 0000 0000 (00h)

7							0
-	-	-	-	-	STOP	ID1S	WKUP-INT

Bit 2 = **STOP**: *Stop bit.*

To enter STOP Mode, write the sequence 1,0,1 to this bit with **three consecutive write operations**. When a correct sequence is recognized, the STOP bit is set and the RCCU puts the MCU in STOP Mode. The software sequence succeeds only if the following conditions are true:

- The WKUP-INT bit is 1,
- All unmasked pending bits are reset,
- At least one mask bit is equal to 1 (at least one external wake-up line is not masked).

Otherwise the MCU cannot enter STOP mode, the program code continues executing and the STOP bit remains cleared.

The bit is reset by hardware if, while the MCU is in STOP mode, a wake-up interrupt comes from any of the unmasked wake-up lines. The STOP bit is at 1 in the two following cases (See "Wake-up Mode Selection" on page 64. for details):

- After the first write instruction of the sequence (a 1 is written to the STOP bit).
- At the end of a successful sequence (i.e. after the third write instruction of the sequence)

Note: The STOP request generated by the WUIMU (that allows the ST9 to enter STOP mode) is ORed with the external STOP pin (active low). This means that if the external STOP pin is forced low, the ST9 will enter STOP mode independently of the status of the STOP bit.

WARNING: Writing the sequence 1,0,1 to the STOP bit will enter STOP mode only if no other register write instructions are executed during the

sequence. If Interrupt or DMA requests (which always perform register write operations) are acknowledged during the sequence, the ST9 will not enter STOP mode: the user must re-enter the sequence to set the STOP bit.

WARNING: Whenever a STOP request is issued to the MCU, a few clock cycles are needed to enter STOP mode (see RCCU chapter for further details). Hence the execution of the instruction following the STOP bit setting sequence might start before entering STOP mode: if such instruction performs a register write operation, the ST9 will not enter in STOP mode. In order to avoid to execute register write instructions after a correct STOP bit setting sequence and before entering the STOP mode, it is mandatory to execute 3NOP instructions after the STOP bit setting sequence.

Bit 1 = **ID1S**: *Interrupt Channel INTD1 Source.*

This bit is set and cleared by software.

0: INT7 external interrupt source selected, excluding wake-up line interrupt requests

1: The 16 external wake-up lines enabled as interrupt sources, replacing the INT7 external pin function

WARNING: To avoid spurious interrupt requests on the INTD1 channel due to changing the interrupt source, do the following before modifying the ID1S bit:

1. Mask the INTD1 interrupt channel (bit 7 of register EIMR - R244, Page 0 - reset to 0).
2. Program the ID1S bit as needed.
3. Clear the IPD1 interrupt pending bit (bit 7 of register EIPR - R243, Page 0).
4. Remove the mask on INTD1 (bit EIMR.7=1).

Bit 0 = **WKUP-INT**: *Wakeup Interrupt.*

This bit is set and cleared by software.

0: The 16 external wakeup lines can be used to generate interrupt requests

1: The 16 external wake-up lines to work as wake-up sources for exiting from STOP mode

WAKE-UP / INTERRUPT LINES MANAGEMENT UNIT (Cont'd)

WAKE-UP MASK REGISTER HIGH (WUMRH)

R250 - Read/Write

Register Page: 57

Reset Value: 0000 0000 (00h)

7							0
WUM15	WUM14	WUM13	WUM12	WUM11	WUM10	WUM9	WUM8

Bit 7:0 = **WUM[15:8]**: *Wake-Up Mask bits.*
 If WUMx is set, an interrupt on channel INTD1 and/or a wake-up event (depending on ID1S and WKUP-INT bits) are generated if the corresponding WUPx pending bit is set. More precisely, if WUMx=1 and WUPx=1 then:

- If ID1S=1 and WKUP-INT=1 then an interrupt on channel INTD1 and a wake-up event are generated.
- If ID1S=1 and WKUP-INT=0 only an interrupt on channel INTD1 is generated.
- If ID1S=0 and WKUP-INT=1 only a wake-up event is generated.
- If ID1S=0 and WKUP-INT=0 neither interrupts on channel INTD1 nor wake-up events are generated. Interrupt requests on channel INTD1 may be generated only from external interrupt source INT7.

If WUMx is reset, no wake-up events can be generated. Interrupt requests on channel INTD1 may be generated only from external interrupt source INT7 (resetting ID1S bit to 0).

WAKE-UP MASK REGISTER LOW (WUMRL)

R251 - Read/Write

Register Page: 57

Reset Value: 0000 0000 (00h)

7							0
WUM7	WUM6	WUM5	WUM4	WUM3	WUM2	WUM1	WUM0

Bit 7:0 = **WUM[7:0]**: *Wake-Up Mask bits.*
 If WUMx is set, an interrupt on channel INTD1 and/or a wake-up event (depending on ID1S and WKUP-INT bits) are generated if the corresponding WUPx pending bit is set. More precisely, if WUMx=1 and WUPx=1 then:

- If ID1S=1 and WKUP-INT=1 then an interrupt on channel INTD1 and a wake-up event are generated.
- If ID1S=1 and WKUP-INT=0 only an interrupt on channel INTD1 is generated.
- If ID1S=0 and WKUP-INT=1 only a wake-up event is generated.
- If ID1S=0 and WKUP-INT=0 neither interrupts on channel INTD1 nor wake-up events are generated. Interrupt requests on channel INTD1 may be generated only from external interrupt source INT7.

If WUMx is reset, no wake-up events can be generated. Interrupt requests on channel INTD1 may be generated only from external interrupt source INT7 (resetting ID1S bit to 0).

WAKE-UP / INTERRUPT LINES MANAGEMENT UNIT (Cont'd)**WAKE-UP TRIGGER REGISTER HIGH (WUTRH)**

R252 - Read/Write

Register Page: 57

Reset Value: 0000 0000 (00h)

7										0
	WUT15	WUT14	WUT13	WUT12	WUT11	WUT10	WUT9	WUT8		

Bit 7:0 = **WUT[15:8]: Wake-Up Trigger Polarity Bits**

These bits are set and cleared by software.

- 0: The corresponding WUPx pending bit will be set on the falling edge of the input wake-up line.
- 1: The corresponding WUPx pending bit will be set on the rising edge of the input wake-up line.

WAKE-UP TRIGGER REGISTER LOW (WUTRL)

R253 - Read/Write

Register Page: 57

Reset Value: 0000 0000 (00h)

7								0	
	WUT7	WUT6	WUT5	WUT4	WUT3	WUT2	WUT1	WUT0	

Bit 7:0 = **WUT[7:0]: Wake-Up Trigger Polarity Bits**

These bits are set and cleared by software.

- 0: The corresponding WUPx pending bit will be set on the falling edge of the input wake-up line.
- 1: The corresponding WUPx pending bit will be set on the rising edge of the input wake-up line.

WARNING

1. As the external wake-up lines are edge triggered, no glitches must be generated on these lines.
2. If either a rising or a falling edge on the external wake-up lines occurs while writing the WUTRH or WUTRL registers, the pending bit will not be set.

WAKE-UP PENDING REGISTER HIGH (WUPRH)

R254 - Read/Write

Register Page: 57

Reset Value: 0000 0000 (00h)

7									0
	WUP15	WUP14	WUP13	WUP12	WUP11	WUP10	WUP9	WUP8	

Bit 7:0 = **WUP[15:8]: Wake-Up Pending Bits**

These bits are set by hardware on occurrence of the trigger event on the corresponding wake-up line. They must be cleared by software. They can be set by software to implement a software interrupt.

- 0: No Wake-up Trigger event occurred
- 1: Wake-up Trigger event occurred

WAKE-UP PENDING REGISTER LOW (WUPRL)

R255 - Read/Write

Register Page: 57

Reset Value: 0000 0000 (00h)

7								0	
	WUP7	WUP6	WUP5	WUP4	WUP3	WUP2	WUP1	WUP0	

Bit 7:0 = **WUP[7:0]: Wake-Up Pending Bits**

These bits are set by hardware on occurrence of the trigger event on the corresponding wake-up line. They must be cleared by software. They can be set by software to implement a software interrupt.

- 0: No Wake-up Trigger event occurred
- 1: Wake-up Trigger event occurred

Note: To avoid losing a trigger event while clearing the pending bits, **it is recommended** to use read-modify-write instructions (AND, BRES, BAND) to clear them.

4 ON-CHIP DIRECT MEMORY ACCESS (DMA)

4.1 INTRODUCTION

The ST9 includes on-chip Direct Memory Access (DMA) in order to provide high-speed data transfer between peripherals and memory or Register File. Multi-channel DMA is fully supported by peripherals having their own controller and DMA channel(s). Each DMA channel transfers data to or from contiguous locations in the Register File, or in Memory. The maximum number of bytes that can be transferred per transaction by each DMA channel is 222 with the Register File, or 65536 with Memory.

The DMA controller in the Peripheral uses an indirect addressing mechanism to DMA Pointers and Counter Registers stored in the Register File. This is the reason why the maximum number of transactions for the Register File is 222, since two Registers are allocated for the Pointer and Counter. Register pairs are used for memory pointers and counters in order to offer the full 65536 byte and count capability.

4.2 DMA PRIORITY LEVELS

The 8 priority levels used for interrupts are also used to prioritize the DMA requests, which are arbitrated in the same arbitration phase as interrupt requests. If the event occurrence requires a DMA transaction, this will take place at the end of the current instruction execution. When an interrupt and a DMA request occur simultaneously, on the same priority level, the DMA request is serviced before the interrupt.

An interrupt priority request must be strictly higher than the CPL value in order to be acknowledged, whereas, for a DMA transaction request, it must be equal to or higher than the CPL value in order to be executed. Thus only DMA transaction requests can be acknowledged when the CPL=0.

DMA requests do not modify the CPL value, since the DMA transaction is not interruptable.

Figure 31. DMA Data Transfer

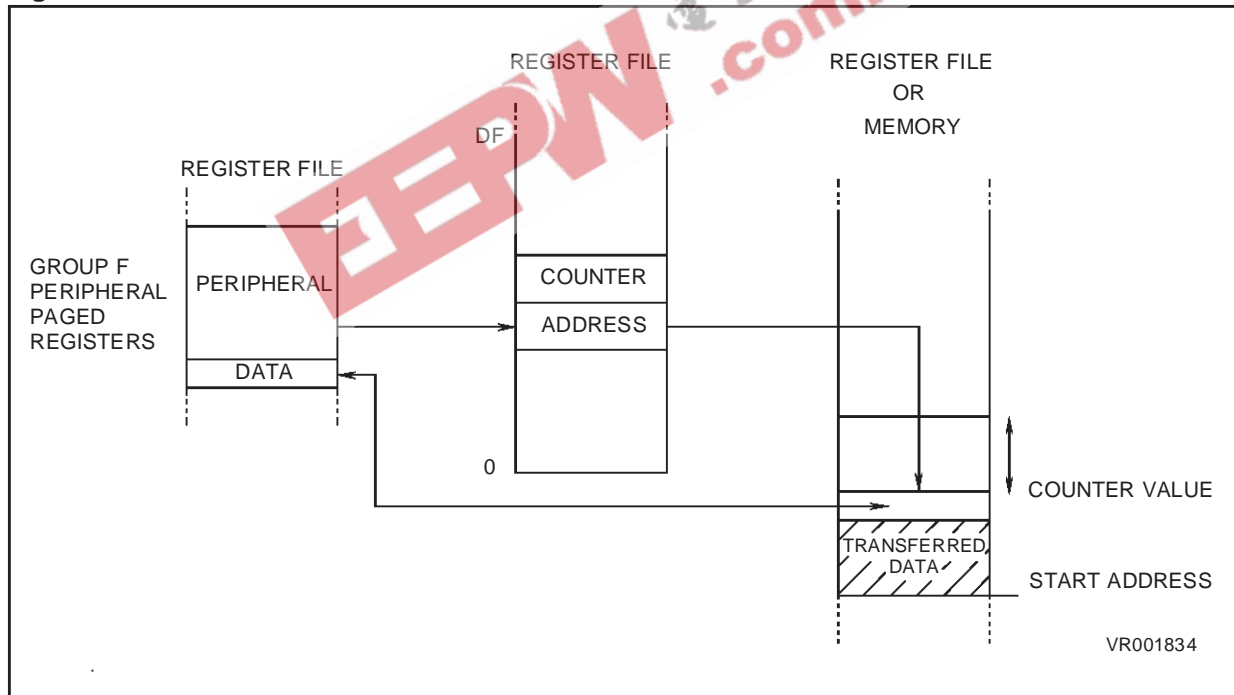

4.3 DMA TRANSACTIONS

The purpose of an on-chip DMA channel is to transfer a block of data between a peripheral and the Register File, or Memory. Each DMA transfer consists of three operations:

- A load from/to the peripheral data register to/from a location of Register File (or Memory) addressed through the DMA Address Register (or Register pair)
- A post-increment of the DMA Address Register (or Register pair)
- A post-decrement of the DMA transaction counter, which contains the number of transactions that have still to be performed.

If the DMA transaction is carried out between **the peripheral and the Register File** (Figure 32), one register is required to hold the DMA Address, and one to hold the DMA transaction counter. These two registers must be located in the Register File: the DMA Address Register in the even address

register, and the DMA Transaction Counter in the next register (odd address). They are pointed to by the DMA Transaction Counter Pointer Register (DCPR), located in the peripheral's paged registers. In order to select a DMA transaction with the Register File, the control bit DCPR.RM (bit 0 of DCPR) must be set.

If the transaction is made between **the peripheral and Memory**, a register pair (16 bits) is required for the DMA Address and the DMA Transaction Counter (Figure 33). Thus, two register pairs must be located in the Register File.

The DMA Transaction Counter is pointed to by the DMA Transaction Counter Pointer Register (DCPR), the DMA Address is pointed to by the DMA Address Pointer Register (DAPR), both DCPR and DAPR are located in the paged registers of the peripheral.

Figure 32. DMA Between Register File and Peripheral

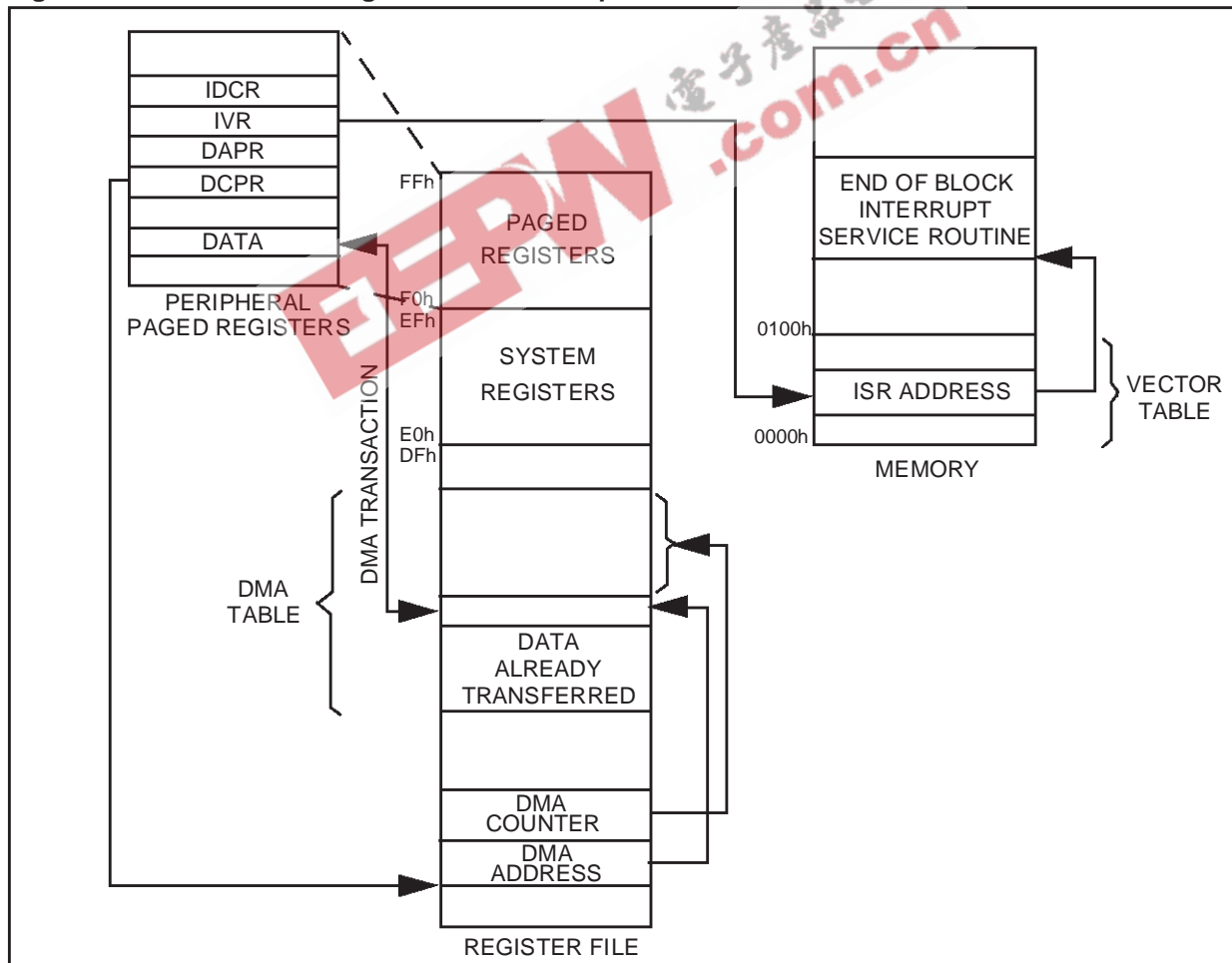

DMA TRANSACTIONS (Cont'd)

When selecting the DMA transaction with memory, bit DCPR.RM (bit 0 of DCPR) must be cleared.

To select between using the ISR or the DMASR register to extend the address, (see Memory Management Unit chapter), the control bit DAPR.PS (bit 0 of DAPR) must be cleared or set respectively.

The DMA transaction Counter must be initialized with the number of transactions to perform and will be decremented after each transaction. The DMA Address must be initialized with the starting address of the DMA table and is increased after each transaction. These two registers must be located between addresses 00h and DFh of the Register File.

Once a DMA channel is initialized, a transfer can start. The direction of the transfer is automatically defined by the type of peripheral and programming mode.

Once the DMA table is completed (the transaction counter reaches 0 value), an Interrupt request to the CPU is generated.

When the Interrupt Pending (IP) bit is set by a hardware event (or by software), and the DMA Mask bit (DM) is set, a DMA request is generated. If the Priority Level of the DMA source is higher than, or equal to, the Current Priority Level (CPL), the DMA transfer is executed at the end of the current instruction. DMA transfers read/write data from/to the location pointed to by the DMA Address Register, the DMA Address register is incremented and the Transaction Counter Register is decremented. When the contents of the Transaction Counter are decremented to zero, the DMA Mask bit (DM) is cleared and an interrupt request is generated, according to the Interrupt Mask bit (End of Block interrupt). This End-of-Block interrupt request is taken into account, depending on the PRL value.

WARNING. DMA requests are not acknowledged if the top level interrupt service is in progress.

Figure 33. DMA Between Memory and Peripheral

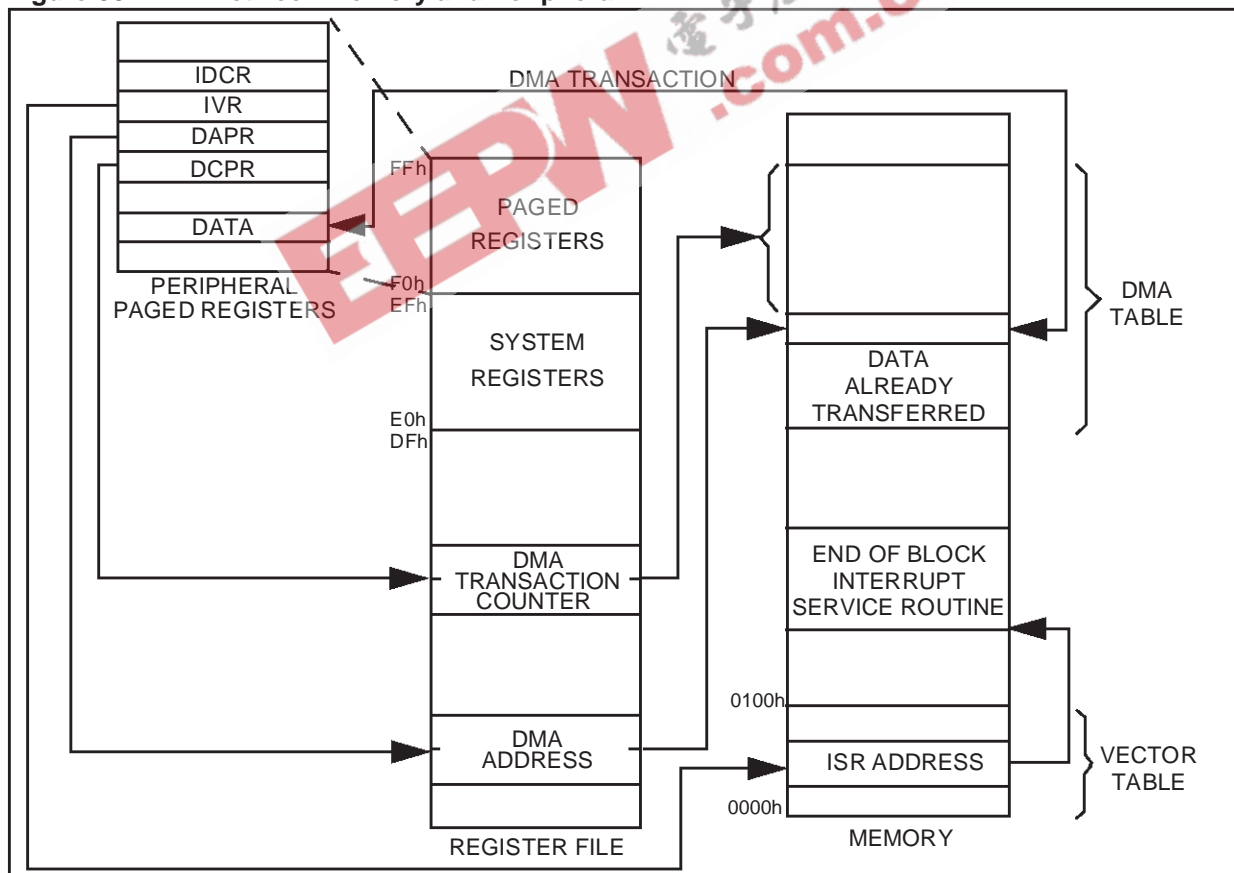

DMA TRANSACTIONS (Cont'd)

4.4 DMA CYCLE TIME

The interrupt and DMA arbitration protocol functions completely asynchronously from instruction flow.

Requests are sampled every 5 CPUCLK cycles.

DMA transactions are executed if their priority allows it.

A DMA transfer with the Register file requires 8 CPUCLK cycles.

A DMA transfer with memory requires 16 CPUCLK cycles, plus any required wait states.

4.5 SWAP MODE

An extra feature which may be found on the DMA channels of some peripherals (e.g. the MultiFunction Timer) is the Swap mode. This feature allows

transfer from two DMA tables alternatively. All the DMA descriptors in the Register File are thus doubled. Two DMA transaction counters and two DMA address pointers allow the definition of two fully independent tables (they only have to belong to the same space, Register File or Memory). The DMA transaction is programmed to start on one of the two tables (say table 0) and, at the end of the block, the DMA controller automatically swaps to the other table (table 1) by pointing to the other DMA descriptors. In this case, the DMA mask (DM bit) control bit is not cleared, but the End Of Block interrupt request is generated to allow the optional updating of the first data table (table 0).

Until the swap mode is disabled, the DMA controller will continue to swap between DMA Table 0 and DMA Table 1.

EEPW.com.cn 电子产品世界

4.6 DMA REGISTERS

As each peripheral DMA channel has its own specific control registers, the following register list should be considered as a general example. The names and register bit allocations shown here may be different from those found in the peripheral chapters.

DMA COUNTER POINTER REGISTER (DCPR)

Read/Write
Address set by Peripheral
Reset value: undefined

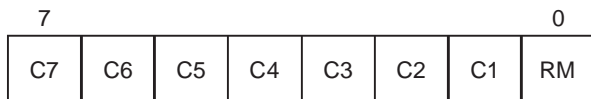

Bit 7:1 = **C[7:1]**: DMA Transaction Counter Pointer.

Software should write the pointer to the DMA Transaction Counter in these bits.

Bit 0 = **RM**: Register File/Memory Selector.

This bit is set and cleared by software.
0: DMA transactions are with memory (see also DAPR.DP)
1: DMA transactions are with the Register File

GENERIC EXTERNAL PERIPHERAL INTERRUPT AND DMA CONTROL (IDCR)

Read/Write
Address set by Peripheral
Reset value: undefined



Bit 5 = **IP**: Interrupt Pending.
This bit is set by hardware when the Trigger Event occurs. It is cleared by hardware when the request is acknowledged. It can be set/cleared by software in order to generate/cancel a pending request.
0: No interrupt pending
1: Interrupt pending

Bit 4 = **DM**: DMA Request Mask.
This bit is set and cleared by software. It is also cleared when the transaction counter reaches zero (unless SWAP mode is active).
0: No DMA request is generated when IP is set.
1: DMA request is generated when IP is set

Bit 3 = **IM**: End of block Interrupt Mask.
This bit is set and cleared by software.
0: No End of block interrupt request is generated when IP is set
1: End of Block interrupt is generated when IP is set. DMA requests depend on the DM bit value as shown in the table below.

DM	IM	Meaning
1	0	A DMA request generated without End of Block interrupt when IP=1
1	1	A DMA request generated with End of Block interrupt when IP=1
0	0	No End of block interrupt or DMA request is generated when IP=1
0	1	An End of block Interrupt is generated without associated DMA request (not used)

Bit 2:0 = **PRL[2:0]**: Source Priority Level.
These bits are set and cleared by software. Refer to Section 4.2 for a description of priority levels.

PRL2	PRL1	PRL0	Source Priority Level
0	0	0	0 Highest
0	0	1	1
0	1	0	2
0	1	1	3
1	0	0	4
1	0	1	5
1	1	0	6
1	1	1	7 Lowest

DMA ADDRESS POINTER REGISTER (DAPR)

Read/Write
Address set by Peripheral
Reset value: undefined

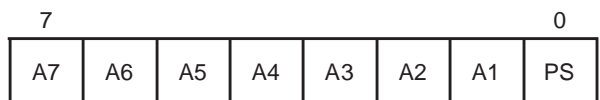

Bit 7:1 = **A[7:1]**: DMA Address Register(s) Pointer
Software should write the pointer to the DMA Address Register(s) in these bits.

Bit 0 = **PS**: Memory Segment Pointer Selector.
This bit is set and cleared by software. It is only meaningful if DAPR.RM=0.
0: The ISR register is used to extend the address of data transferred by DMA (see MMU chapter).
1: The DMASR register is used to extend the address of data transferred by DMA (see MMU chapter).

5 RESET AND CLOCK CONTROL UNIT (RCCU)

5.1 INTRODUCTION

The Reset and Clock Control Unit (RCCU) comprises two distinct sections:

- the Clock Control Unit, which generates and manages the internal clock signals.
- the Reset/Stop Manager, which detects and flags Hardware, Software and Watchdog generated resets.

On ST9 devices where the external Stop pin is available, this circuit also detects and manages the externally triggered Stop mode, during which all oscillators are frozen in order to achieve the lowest possible power consumption.

5.2 CLOCK CONTROL UNIT

The Clock Control Unit generates the internal clocks for the CPU core (CPUCLK) and for the on-chip peripherals (INTCLK). The Clock Control Unit may be driven by an external crystal circuit, connected to the OSCIN and OSCOUT pins, or by an external pulse generator, connected to OSCIN (see Figure 42 and Figure 44). Another clock source named CK_AF can be provided from the internal RC oscillator.

5.2.1 Clock Control Unit Overview

As shown in Figure 34, a programmable divider can divide the CLOCK1 input clock signal by two. The resulting signal, CLOCK2, is the reference input clock to the programmable Phase Locked Loop frequency multiplier, which is capable of multiplying the clock frequency by a factor of 6, 8, 10 or 14; the multiplied clock is then divided by a pro-

grammable divider, by a factor of 1 to 7. By this means, the ST9 can operate with cheaper, medium frequency (3-5 MHz) crystals, while still providing a high frequency internal clock for maximum system performance; the range of available multiplication and division factors allow a great number of operating clock frequencies to be derived from a single crystal frequency. The undivided PLL clock is also available for special purposes (high-speed peripheral).

For low power operation, especially in Wait for Interrupt mode, the Clock Multiplier unit may be turned off, whereupon the output clock signal may be programmed as CLOCK2 divided by 16. For further power reduction, an internal RC oscillator with a frequency of 85KHZ (+/- 40%) is available to provide the CK_AF clock internally if the external clock source is not used. During the execution of a WFI in Low Power mode this clock is further divided by 16 to reduce power consumption (for the selection of this signal refer to the description the CK_AF clock source in the following sections).

The internal system clock, INTCLK, is routed to all on-chip peripherals, as well as to the programmable Clock Prescaler Unit which generates the clock for the CPU core (CPUCLK).

The Clock Prescaler is programmable and can slow the CPU clock by a factor of up to 8, allowing the programmer to reduce CPU processing speed, and thus power consumption, while maintaining a high speed clock to the peripherals. This is particularly useful when little actual processing is being done by the CPU and the peripherals are doing most of the work.

Figure 34. Clock Control Unit Simplified Block Diagram

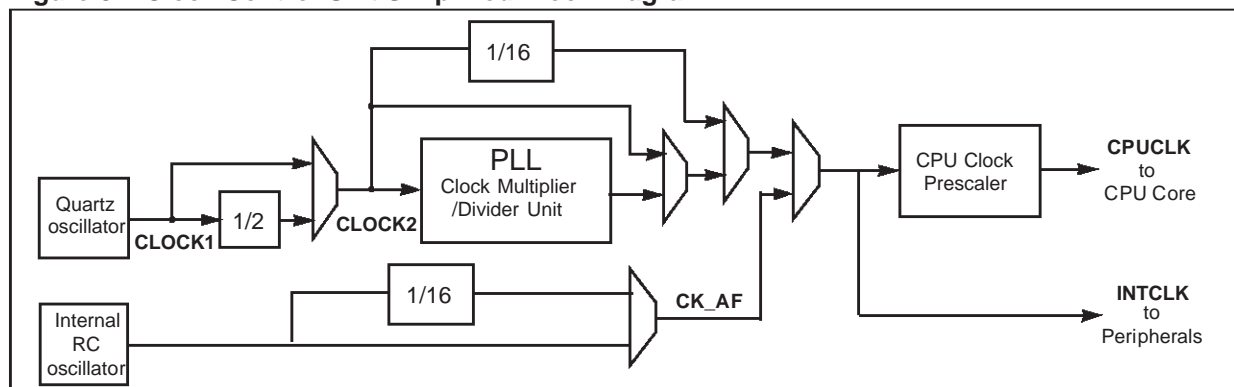

ST92163 - RESET AND CLOCK CONTROL UNIT (RCCU)

Figure 35. ST92163 Clock Distribution Diagram

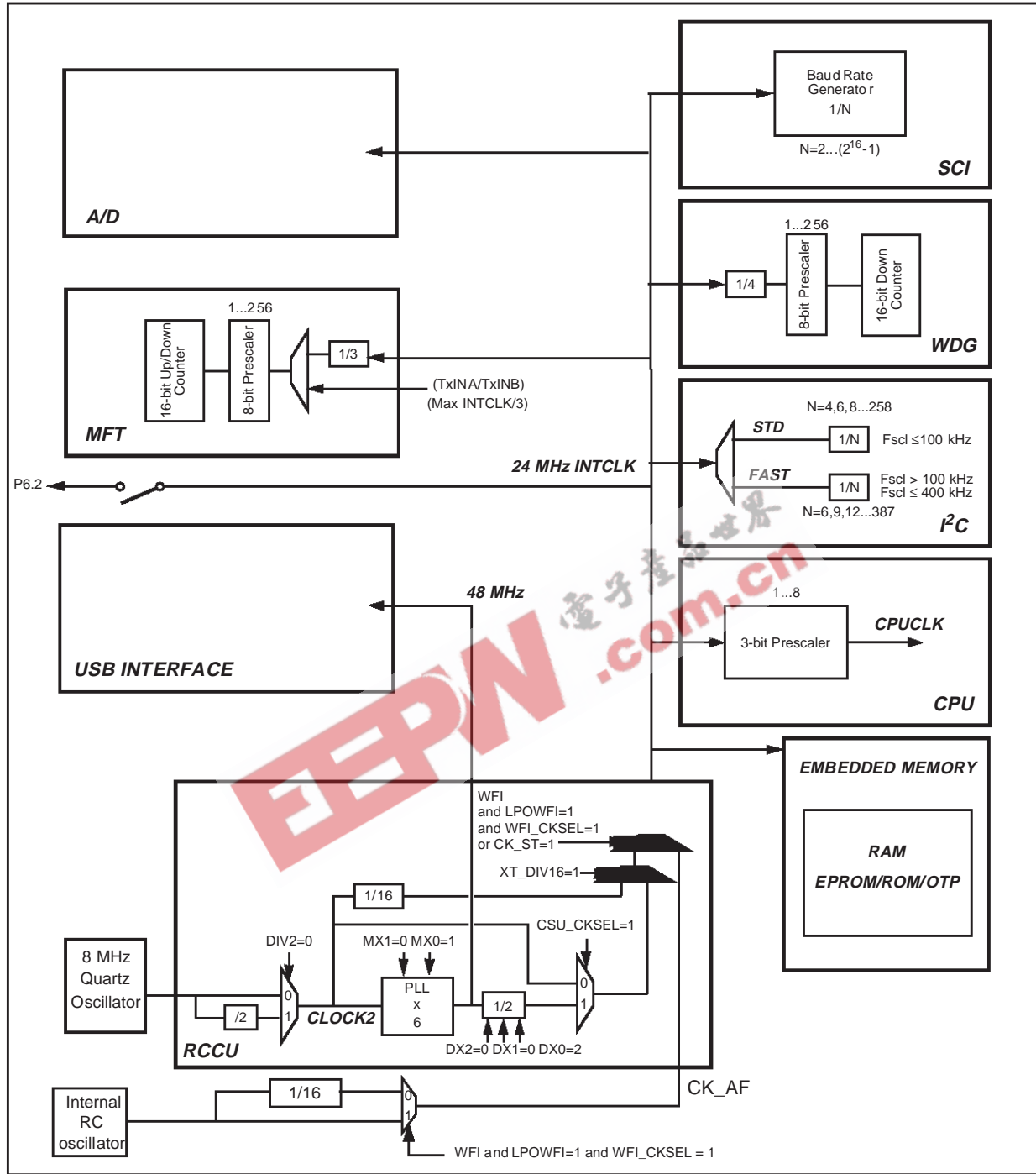

5.3 CLOCK MANAGEMENT

The various programmable features and operating modes of the CCU are handled by four registers:

- **MODER** (Mode Register)
This is a System Register (R235, Group E).
- **CLK_FLAG** (Clock Flag Register)
This is a Paged Register (R242, Page 55).

The input clock divide-by-two and the CPU clock prescaler factors are handled by this register.

This register contains various status flags, as well as control bits for clock selection.

- **CLKCTL** (Clock Control Register)
This is a Paged Register (R240, Page 55).
- **PLLCONF** (PLL Configuration Register)
This is a Paged Register (R246, Page 55).

The low power modes and the interpretation of the HALT instruction are handled by this register.

The PLL multiplication and division factors are programmed in this register.

Figure 36. Clock Control Unit Programming

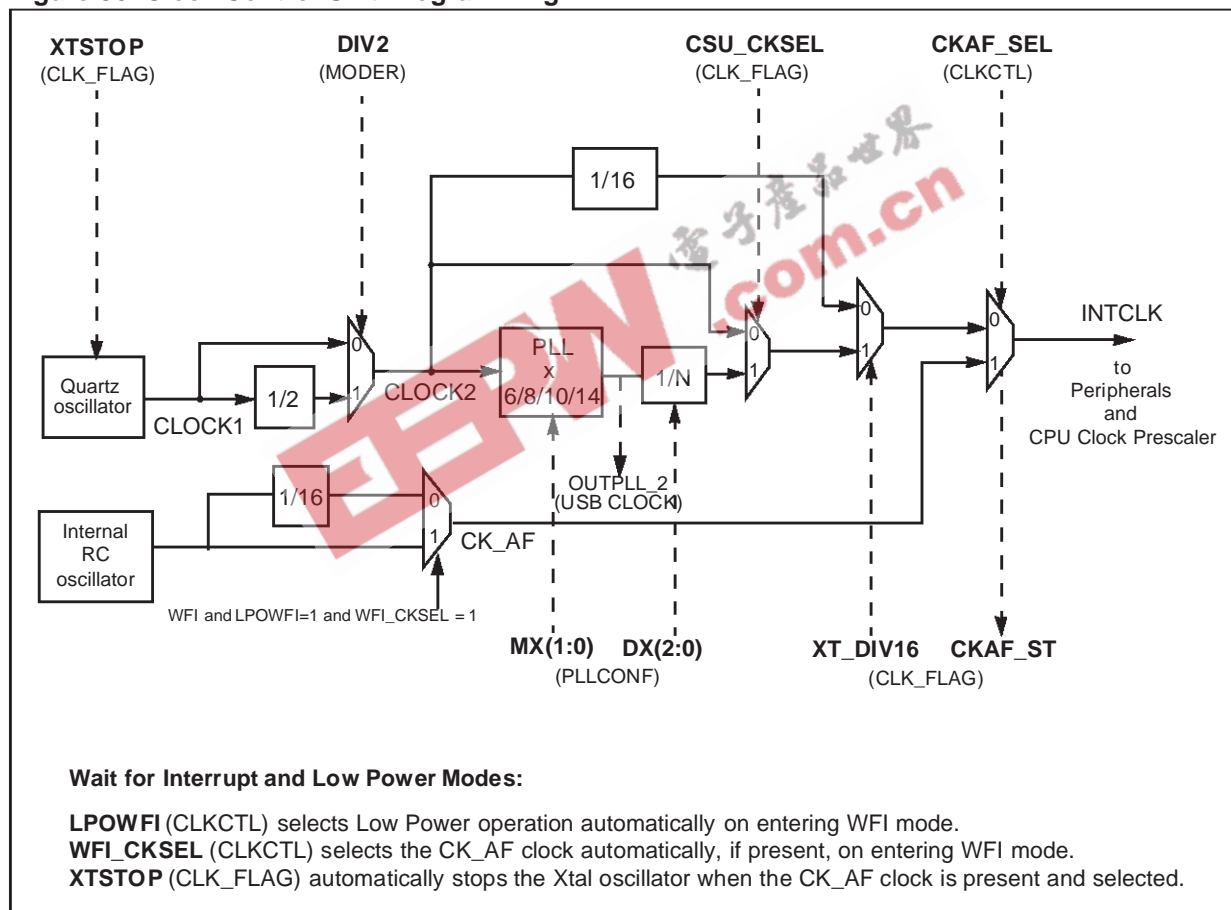

CLOCK MANAGEMENT (Cont'd)

5.3.1 PLL Clock Multiplier Programming

The CLOCK1 signal generated by the oscillator drives a programmable divide-by-two circuit. If the DIV2 control bit in MODER is set (Reset Condition), CLOCK2, is equal to CLOCK1 divided by two; if DIV2 is reset, CLOCK2 is identical to CLOCK1. A CLOCK1 signal with a semiperiod (high or low) shorter than 40ns is forbidden if the divider by two is disabled.

When the PLL is active, it multiplies CLOCK2 by 6, 8, 10 or 14, depending on the status of the MX0-1 bits in PLLCONF. The multiplied clock is then divided by a factor in the range 1 to 7, determined by the status of the DX0-2 bits; when these bits are programmed to 111, the PLL is switched off.

Following a RESET phase, programming bits DX0-2 to a value different from 111 will turn the PLL on. After allowing a stabilisation period for the PLL, setting the CSU_CKSEL bit in the CLK_FLAG Register selects the multiplier clock. This peripheral contains a lock-in logic that verifies if the PLL is locked to the CLOCK2 frequency. The bit LOCK in CLK_FLAG register becomes 1 when this event occurs.

The maximum frequency allowed for INTCLK is 25MHz for 5V operation, and 12MHz for 3V operation. Care is required, when programming the PLL multiplier and divider factors, not to exceed the maximum permissible operating frequency for INTCLK, according to supply voltage.

The ST9 being a static machine, there is no lower limit for INTCLK. However, below 1MHz, A/D converter precision (if present) decreases.

5.3.2 CPU Clock Prescaling

The system clock, INTCLK, which may be the output of the PLL clock multiplier, CLOCK2, CLOCK2/16 or CK_AF, drives a programmable prescaler which generates the basic time base, CPUCLK, for the instruction executor of the ST9 CPU core. This allows the user to slow down program execution during non processor intensive routines, thus reducing power dissipation.

The internal peripherals are not affected by the CPUCLK prescaler and continue to operate at the full INTCLK frequency. This is particularly useful

when little processing is being done and the peripherals are doing most of the work.

The prescaler divides the input clock by the value programmed in the control bits PRS2,1,0 in the MODER register. If the prescaler value is zero, no prescaling takes place, thus CPUCLK has the same period and phase as INTCLK. If the value is different from 0, the prescaling is equal to the value plus one, ranging thus from two (PRS2,1,0 = 1) to eight (PRS2,1,0 = 7).

The clock generated is shown in Figure 37, and it will be noted that the prescaling of the clock does not preserve the 50% duty cycle, since the high level is stretched to replace the missing cycles.

This is analogous to the introduction of wait cycles for access to external memory. When External Memory Wait or Bus Request events occur, CPUCLK is stretched at the high level for the whole period required by the function.

Figure 37. CPU Clock Prescaling

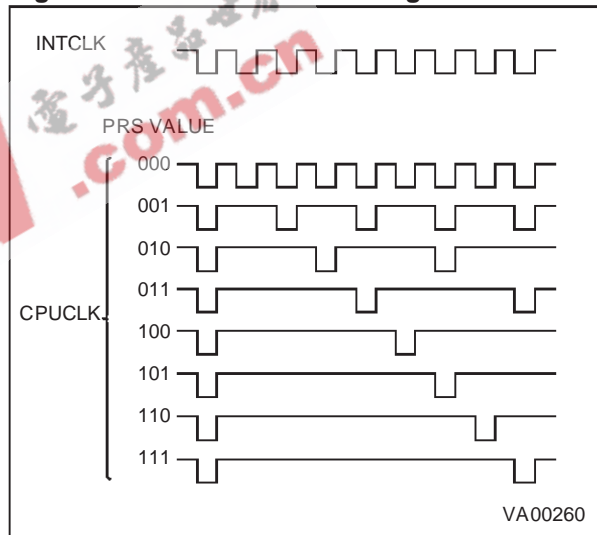

5.3.3 Peripheral Clock

The system clock, INTCLK, which may be the output of the PLL clock multiplier, CLOCK2, CLOCK2/16 or CK_AF, is also routed to all ST9 on-chip peripherals and acts as the central timebase for all timing functions.

CLOCK MANAGEMENT (Cont'd)

5.3.4 Low Power Modes

The user can select an automatic slowdown of clock frequency during Wait for Interrupt operation, thus idling in low power mode while waiting for an interrupt. In WFI operation the clock to the CPU core (CPUCLK) is stopped, thus suspending program execution, while the clock to the peripherals (INTCLK) may be programmed as described in the following paragraphs. An example of Low Power operation in WFI is illustrated in Figure 38.

If low power operation during WFI is disabled (LPOWFI bit = 0 in the CLKCTL Register), the CPU CLK is stopped but INTCLK is unchanged.

If low power operation during Wait for Interrupt is enabled (LPOWFI bit = 1 in the CLKCTL Register), as soon as the CPU executes the WFI instruction, the PLL is turned off and the system clock will be forced to CLOCK2 divided by 16, or to CK_AF, if this has been selected by setting WFI_CKSEL, and providing CKAF_ST is set, thus indicating that the internal RC oscillator is selected.

If the external clock source is used, the crystal oscillator may be stopped by setting the XTSTOP bit, providing that the CK_AK clock is present and selected, indicated by CKAF_ST being set. The crystal oscillator will be stopped automatically on entering WFI if the WFI_CKSEL bit has been set. It

should be noted that selecting a non-existent CK_AF clock source is impossible, since such a selection requires that the auxiliary clock source be actually present and selected. In no event can a non-existent clock source be selected inadvertently.

It is up to the user program to switch back to a faster clock on the occurrence of an interrupt, taking care to respect the oscillator and PLL stabilisation delays, as appropriate. It should be noted that any of the low power modes may also be selected explicitly by the user program even when not in Wait for Interrupt mode, by setting the appropriate bits.

5.3.5 Interrupt Generation

System clock selection modifies the CLKCTL and CLK_FLAG registers.

The clock control unit generates an external interrupt request when CK_AF and CLOCK2/16 are selected or deselected as system clock source, as well as when the system clock restarts after a hardware stop (when the STOP MODE feature is available on the specific device). This interrupt can be masked by resetting the INT_SEL bit in the CLKCTL register. In the RCCU the interrupt is generated with a high to low transition (see interrupt and DMA chapters for further information).

Table 13. Summary of Operating Modes using main Crystal Controlled Oscillator

MODE	INTCLK	CPUCLK	DIV2	PRS0-2	CSU_CKSEL	MX0-1	DX2-0	LPOWFI	XT_DIV16
PLL x BY 14	XTAL/2 x (14/D)	INTCLK/N	1	N-1	1	1 0	D-1	X	1
PLL x BY 10	XTAL/2 x (10/D)	INTCLK/N	1	N-1	1	0 0	D-1	X	1
PLL x BY 8	XTAL/2 x (8/D)	INTCLK/N	1	N-1	1	1 1	D-1	X	1
PLL x BY 6	XTAL/2 x (6/D)	INTCLK/N	1	N-1	1	0 1	D-1	X	1
SLOW 1	XTAL/2	INTCLK/N	1	N-1	X	X	111	X	1
SLOW 2	XTAL/32	INTCLK/N	1	N-1	X	X	X	X	0
WAIT FOR INTERRUPT	If LPOWFI=0, no changes occur on INTCLK, but CPUCLK is stopped anyway.								
LOW POWER WAIT FOR INTERRUPT	XTAL/32	STOP	1	X	X	X	X	1	1
RESET	XTAL/2	INTCLK	1	0	0	00	111	0	1
EXAMPLE XTAL=4.4 MHz	2.2*10/2 = 11MHz	11MHz	1	0	1	00	001	X	1

Figure 38. Example of Low Power Mode programming

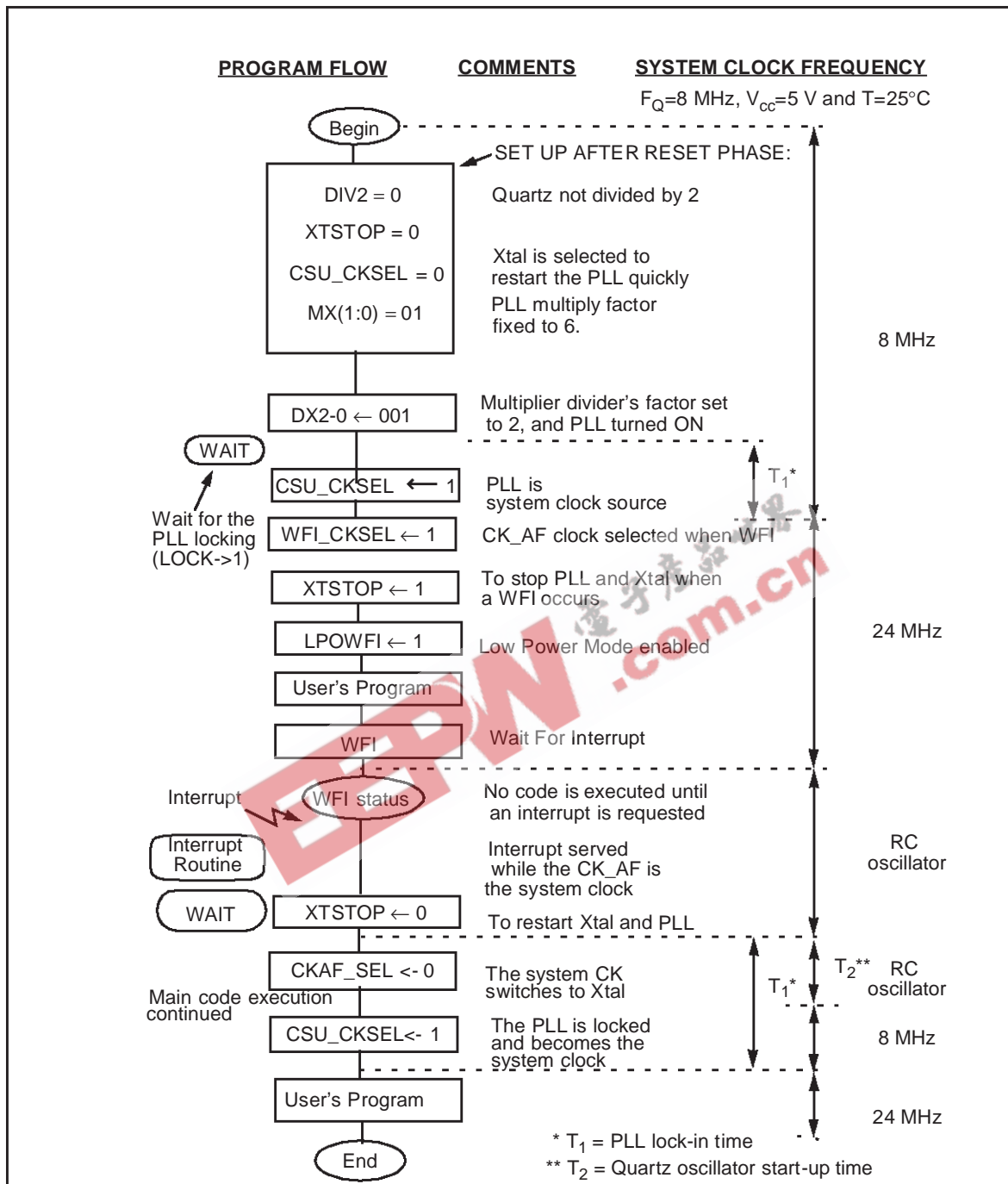

5.4 CLOCK CONTROL REGISTERS

MODE REGISTER (MODER)

R235 - Read/Write
System Register
Reset Value: 1110 0000 (E0h)

7	0
-	-
-	-
DIV2	PRS2
PRS1	PRS0
-	-
-	-

***Note:** This register contains bits which relate to other functions; these are described in the chapter dealing with Device Architecture. Only those bits relating to Clock functions are described here.

Bit 5 = **DIV2**: OSCIN Divided by 2.
This bit controls the divide by 2 circuit which operates on the OSCIN Clock.
0: No division of the OSCIN Clock
1: OSCIN clock is internally divided by 2

Bit 4:2 = **PRS[2:0]**: Clock Prescaling.
These bits define the prescaler value used to prescale CPUCLK from INTCLK. When these three bits are reset, the CPUCLK is not prescaled, and is equal to INTCLK; in all other cases, the internal clock is prescaled by the value of these three bits plus one.

CLOCK CONTROL REGISTER (CLKCTL)

R240 - Read Write
Register Page: 55
Reset Value: 0000 0000 (00h)

7	0
INT_S EL	-
-	-
-	-
SRE- SEN	CKAF_S EL
WFI_CKS EL	LPOW FI

Bit 7 = **INT_SEL**: Interrupt Selection.
0: Select the external interrupt pin as interrupt source (Reset state)
1: Select the internal RCCU interrupt (see Section 5.3.5)

Bit 6:4 = **Reserved**.
Must be kept reset for normal operation.

Bit 3 = **SRESEN**: Software Reset Enable.
0: The HALT instruction turns off the quartz, the PLL and the CCU
1: A Reset is generated when HALT is executed

Bit 2 = **CKAF_SEL**: Alternate Function Clock Select.
0: CK_AF clock not selected
1: Select CK_AF clock

Note: To check if the selection has actually occurred, check that CKAF_ST is set. If no CK_AF clock is present, the selection will not occur.

Bit 1 = **WFI_CKSEL**: WFI Clock Select.
This bit selects the clock used in Low power WFI mode if LPOWFI = 1.
0: INTCLK during WFI is CLOCK2/16
1: INTCLK during WFI is CK_AF, providing it is present. In effect this bit sets CKAF_SEL in WFI mode

WARNING: When the CK_AF is selected as Low Power WFI clock but the XTAL is not turned off (R242.4 = 0), after exiting from the WFI, CK_AF will be still selected as system clock. In this case, reset the R240.2 bit to switch back to the XT.

Bit 0 = **LPOWFI**: Low Power mode during Wait For Interrupt.
0: Low Power mode during WFI disabled. When WFI is executed, the CPUCLK is stopped and INTCLK is unchanged
1: The ST9 enters Low Power mode when the WFI instruction is executed. The clock during this state depends on WFI_CKSEL

CLOCK CONTROL REGISTERS

CLOCK FLAG REGISTER (CLK_FLAG)

R242 -Read/Write

Register Page: 55

Reset Value: 0100 1000 after a Watchdog Reset

Reset Value: 0010 1000 after a Software Reset

Reset Value: 0000 1000 after a Power-On Reset

7	0						
EX_ STP	WDG RES	SOFT RES	XT- STOP	XT_ DIV16	CKAF_ ST	LOC K	CSU_ CK- SEL

WARNING: If this register is accessed with a logical instruction, such as AND or OR, some bits may not be set as expected.

WARNING: If you select the CK_AF as system clock and turn off the oscillator (bits R240.2 and R242.4 at 1), and then switch back to the XT clock by resetting the R240.2 bit, you must wait for the oscillator to restart correctly (12ms).

Bit 7 = **EX_STP**: External Stop flag

This bit is set by hardware and cleared by software.

0: No External Stop condition occurred

1: External Stop condition occurred

Bit 6 = **WDGRES**: Watchdog reset flag.

This bit is read only.

0: No Watchdog reset occurred

1: Watchdog reset occurred

Bit 5 = **SOFTRES**: Software Reset Flag.

This bit is read only.

0: No software reset occurred

1: Software reset occurred (HALT instruction)

Bit 4 = **XTSTOP**: External Stop Enable.

0: External stop disabled

1: The Xtal oscillator will be stopped as soon as the CK_AF clock is present and selected, whether this is done explicitly by the user program, or as a result of WFI, if WFI_CKSEL has previously been set to select the CK_AF clock during WFI.

WARNING: When the program writes '1' to the XTSTOP bit, it will still be read as 0 and is only set when the CK_AF clock is running (CKAF_ST=1).

Take care, as any operation such as a subsequent AND with '1' or an OR with '0' to the XTSTOP bit will reset it and the oscillator will not be stopped even if CKAF_ST is subsequently set.

Bit 3 = **XT_DIV16**: CLOCK/16 Selection

This bit is set and cleared by software. An interrupt is generated when the bit is toggled.

0: CLOCK2/16 is selected and the PLL is off

1: The input is CLOCK2 (or the PLL output depending on the value of CSU_CKSEL)

WARNING: After this bit is modified from 0 to 1, take care that the PLL lock-in time has elapsed before setting the CSU_CKSEL bit.

Bit 2 = **CKAF_ST**: (Read Only)

If set, indicates that the alternate function clock has been selected. If no CK_AF clock signal is present on the pin, the selection will not occur. If reset, the PLL clock, CLOCK2 or CLOCK2/16 is selected (depending on bit 0).

Bit 1 = **LOCK**: PLL locked-in

This bit is read only.

0: The PLL is turned off or not locked and cannot be selected as system clock source.

1: The PLL is locked

Bit 0 = **CSU_CKSEL**: CSU Clock Select

This bit is set and cleared by software. It also cleared by hardware when:

- bits DX[2:0] (PLLCONF) are set to 111;
- the quartz is stopped (by hardware or software);
- WFI is executed while the LPOWFI bit is set;
- the XT_DIV16 bit (CLK_FLAG) is forced to '0'.

This prevents the PLL, when not yet locked, from providing an irregular clock. Furthermore, a '0' stored in this bit speeds up the PLL's locking.

0: CLOCK2 provides the system clock

1: The PLL Multiplier provides the system clock.

NOTE: Setting the CKAF_SEL bit overrides any other clock selection. Resetting the XT_DIV16 bit overrides the CSU_CKSEL selection

PLL CONFIGURATION REGISTER (PLLCONF)

R246 - Read/Write
 Register Page: 55
 Reset Value: xx00 x111

7							0
-	-	MX1	MX0	-	DX2	DX1	DX0

Bit 7:6 = Reserved.

Bit 5:4 = **MX[1:0]**: PLL Multiplication Factor.
 Refer to Table 14 for multiplier settings.

Bit 3 = Reserved.

Bit 2:0 = **DX[2:0]**: PLL output clock divider factor.
 Refer to Table 15 for divider settings.

Table 14. PLL Multiplication Factors

MX1	MX0	CLOCK2 x
1	0	14
0	0	10
1	1	8
0	1	6

Table 15. Divider Configuration

DX2	DX1	DX0	CK
0	0	0	PLL CLOCK/1
0	0	1	PLL CLOCK/2
0	1	0	PLL CLOCK/3
0	1	1	PLL CLOCK/4
1	0	0	PLL CLOCK/5
1	0	1	PLL CLOCK/6
1	1	0	PLL CLOCK/7
1	1	1	CLOCK2 (PLL OFF, Reset State)

Figure 39. RCCU General Timing

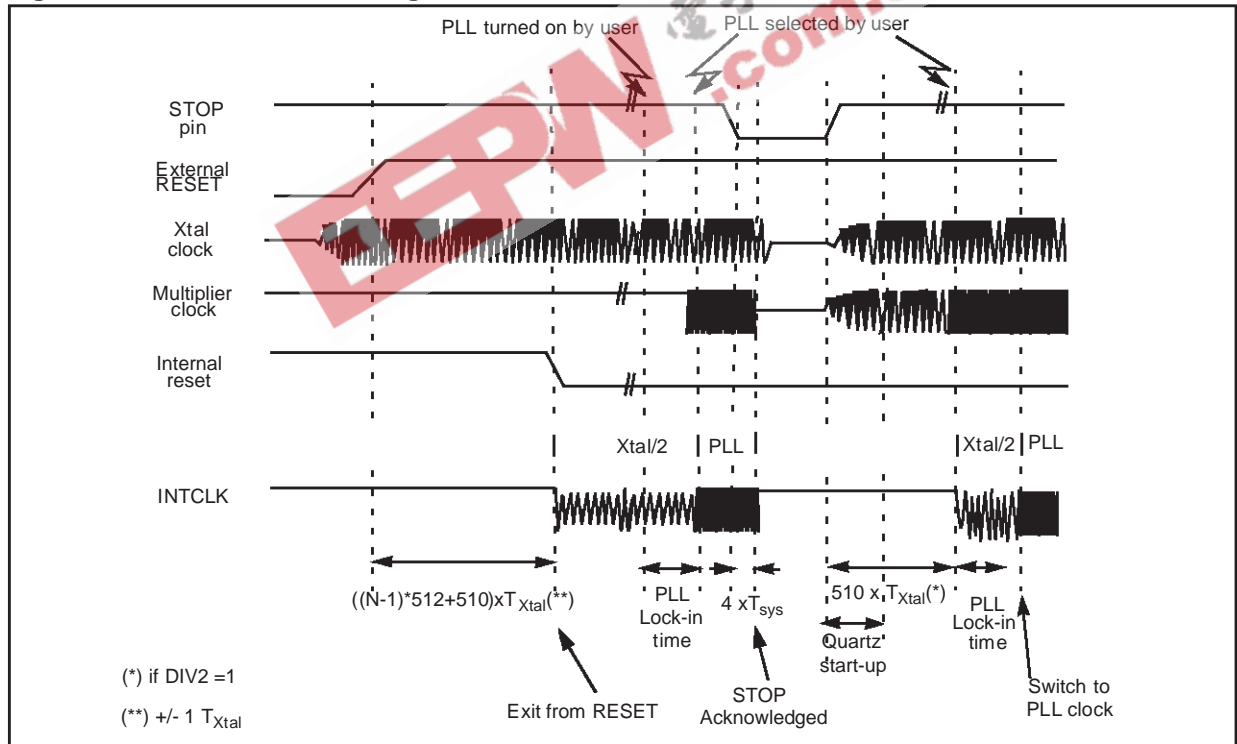

Figure 40. RCCU Timing during STOP (CK_AF System Clock)

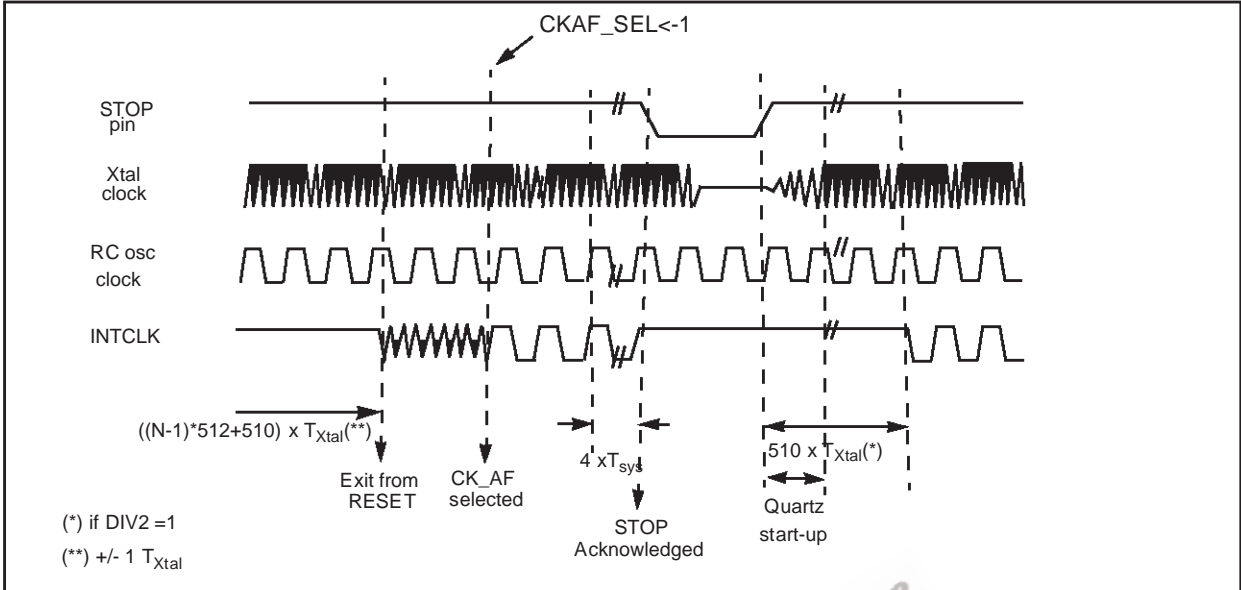
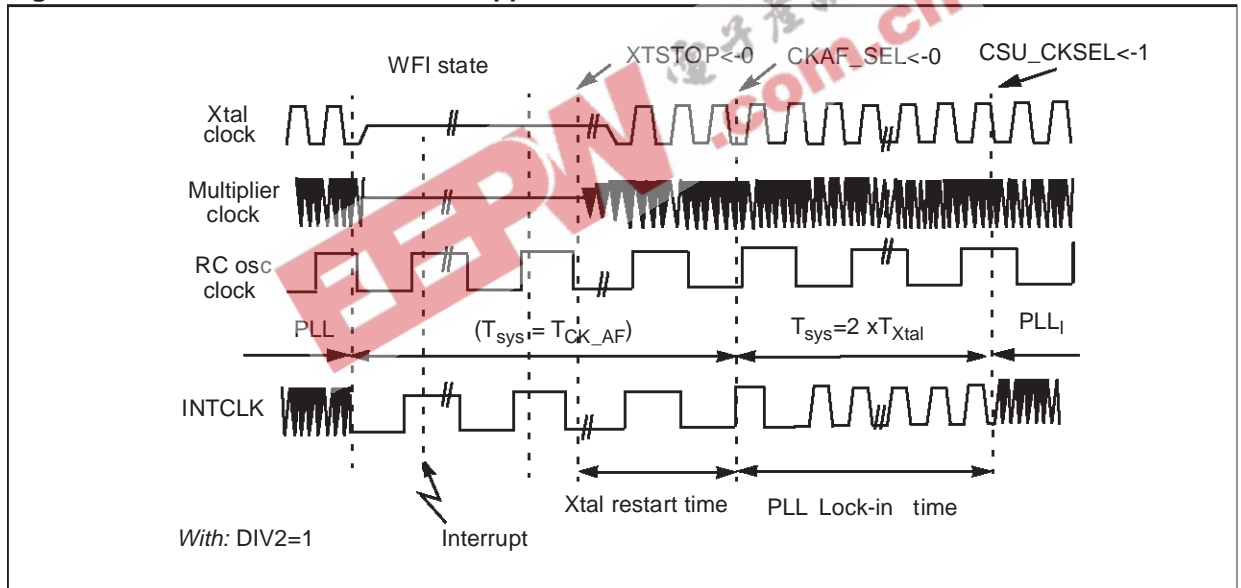

Figure 41. Low Power Mode with a Stopped Quartz Oscillator



5.5 OSCILLATOR CHARACTERISTICS

The oscillator circuit uses an inverting gate circuit with tri-state output.

Notes: Owing to the Q factor required, Ceramic Resonators may not provide a reliable oscillator source.

OSCOUT must not be directly used to drive external circuits.

When the oscillator is stopped, OSCOUT goes high impedance.

In Halt mode, set by means of the HALT instruction, the parallel resistor, R, is disconnected and the oscillator is disabled, forcing the internal clock, CLOCK1, to a high level, and OSCOUT to a high impedance state.

To exit the HALT condition and restart the oscillator, an external RESET pulse is required.

It should be noted that, if the Watchdog function is enabled, a HALT instruction will not disable the oscillator. This to avoid stopping the Watchdog if a HALT code is executed in error. When this occurs, the CPU will be reset when the Watchdog times out or when an external reset is applied.

Table 16. Oscillator Transconductance

Symbol	Voltage range	Min	Typ	Max	Unit
gm	4.0-5.5V	0.77	1.5	2.4	mA/V
	3.0-4.0V	0.5	0.73	1.47	

Figure 42. Crystal Oscillator

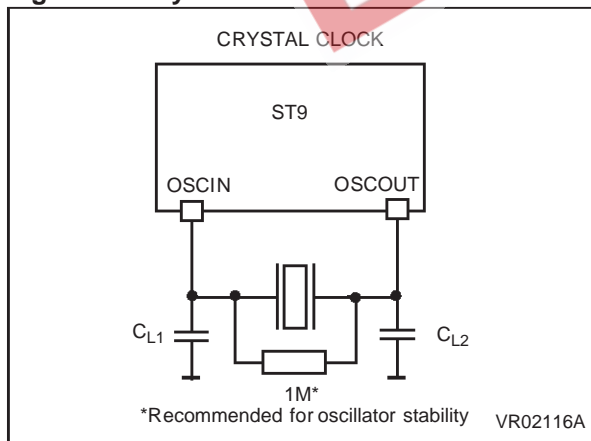

Table 17. Crystal Internal Resistance

Symbol	Conditions	C ₁ =C ₂ = 56pF	C ₁ =C ₂ = 47pF	C ₁ =C ₂ = 33pF	C ₁ =C ₂ = 22pF
R _{smax} (ohm)	4.0-5.5V Freq.=8MHz	50 Ω	65Ω	120Ω	180Ω
	3.0-4.0V Freq.=8MHz	30 Ω	40Ω	70Ω	110Ω

Legend:

C₁, C₂: Maximum Total Capacitances on pins OSCIN and OSCOUT (the value includes the external capacitance tied to the pin CL1 and CL2 plus the parasitic capacitance of the board and of the device).

R_{smax}: The equivalent serial resistor of the crystal.

Note 1: The tables are relative to the fundamental quartz crystal only (not ceramic resonator).

Note 2: To reduce the parasitic capacitance, it is recommended to place the crystal as close to the ST9 MCU as possible.

WARNING: At low temperature, frost and humidity might prevent the correct start-up of the oscillator.

Figure 43. Internal Oscillator Schematic

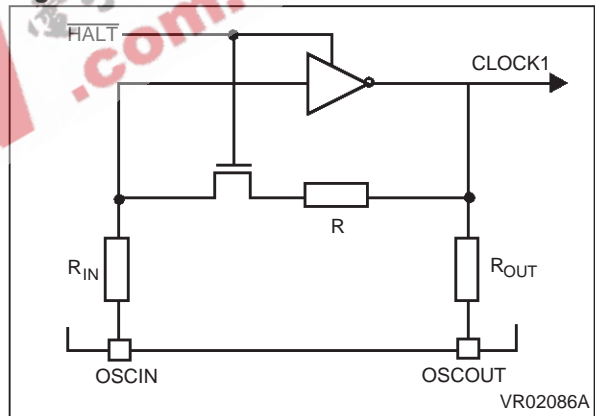
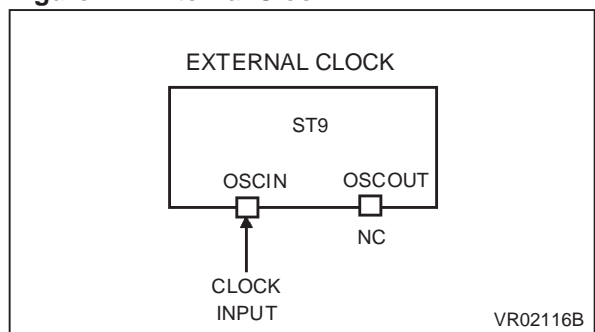

Figure 44. External Clock



5.6 RESET/STOP MANAGER

The Reset/Stop Manager resets the MCU when one of the three following events occurs:

- A Hardware reset, initiated by a low level on the Reset pin.
- A Software reset, initiated by a HALT instruction (when enabled).
- A Watchdog end of count condition.

The event which caused the last Reset is flagged in the CLK_FLAG register, by setting the SOF-

TRES or the WDGRES bits respectively; a hardware initiated reset will leave both these bits reset.

The hardware reset overrides all other conditions and forces the ST9 to the reset state. During Reset, the internal registers are set to their reset values, where these are defined, and the I/O pins are set to the Bidirectional Weak Pull-up mode.

Reset is asynchronous: as soon as the reset pin is driven low, a Reset cycle is initiated.

Figure 45. Oscillator Start-up Sequence and Reset Timing

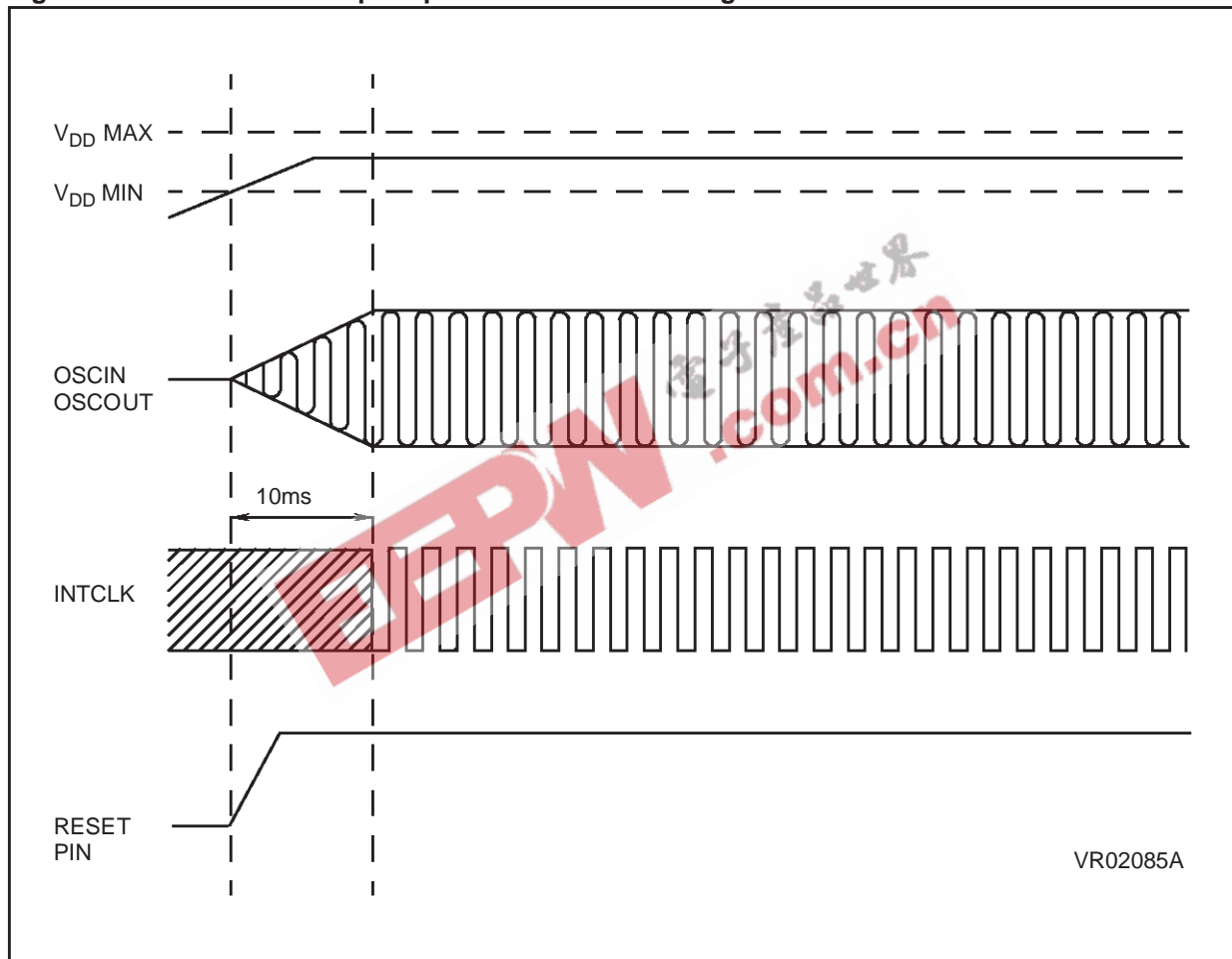

RESET/STOP MANAGER (Cont'd)

The on-chip Timer/Watchdog generates a reset condition if the Watchdog mode is enabled (WCR.WDEN cleared, R252 page 0), and if the programmed period elapses without the specific code (AAh, 55h) written to the appropriate register. The input pin RESET is not driven low by the on-chip reset generated by the Timer/Watchdog.

When the Reset pin goes high again, a delay of 10 ms occurs before exiting the Reset state (+1 CLOCK1 period, depending on the delay between the rising edge of the Reset pin and the first rising edge of CLOCK1). Subsequently a short Boot routine is executed from the device internal Boot ROM, and control then passes to the user program.

The Boot routine sets the device characteristics and loads the correct values in the Memory Management Unit's pointer registers, so that these point to the physical memory areas as mapped in the specific device. The precise duration of this short Boot routine varies from device to device, depending on the Boot ROM contents.

At the end of the Boot routine the Program Counter will be set to the location specified in the Reset Vector located in the lowest two bytes of memory.

5.6.1 Reset Pin Timing

To improve the noise immunity of the device, the Reset pin has a Schmitt trigger input circuit with hysteresis. In addition, a filter will prevent an unwanted reset in case of a single glitch of less than 50 ns on the Reset pin. The device is certain to reset if a negative pulse of more than 20µs is applied. When the reset pin goes high again, a delay of up to 4µs (at 8 MHz.) will elapse before the RCCU detects this rising front. From this event on, 79870 (about 10 ms at 8 MHz.) oscillator clock cycles (CLOCK1) are counted before exiting the Reset state (+1 CLOCK1 period depending on the delay between the positive edge the RCCU detects and the first rising edge of CLOCK1)

If the ST9 is a ROMLESS version, without on-chip program memory, the memory interface ports are set to external memory mode (i.e Alternate Function) and the memory accesses are made to external Program memory with wait cycles insertion.

Figure 46. Recommended Signal to be Applied on Reset Pin

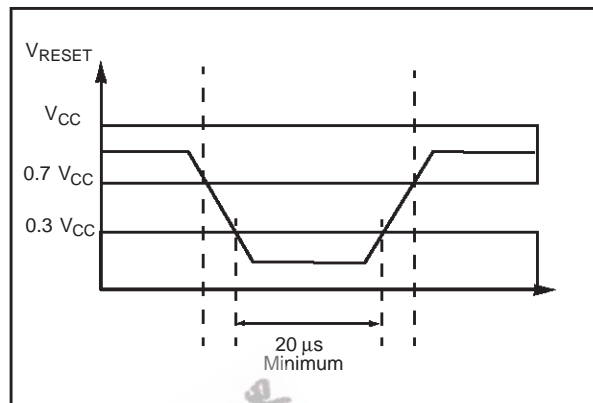

5.7 STOP MODE

In Stop mode, the Reset/Stop Manager can also stop all oscillators without resetting the device.

For information on entering and exiting Stop Mode, refer to the Wake-Up/Interrupt lines management unit (WUIMU) chapter. In Stop Mode, all context information is preserved and the internal clock is frozen in the high state.

On exiting Stop mode, the MCU resumes execution of the user program after a delay of 255 CLOCK2 periods, an interrupt is generated and the EX_STP bit in CLK_FLAG is set.

5.8 LOW VOLTAGE DETECTOR (LVD) RESET

The on-chip Low Voltage Detector (LVD) generates a static reset when the supply voltage is below a reference value. The LVD works both during power-on as well as when the power supply drops (brown-out). The reference value for the voltage drop is lower than the reference value for power-on in order to avoid a parasitic reset when the MCU starts running and sinks current on the supply (hysteresis).

The LVD circuitry generates a reset when V_{DD} is below:

- V_{LVDUP} when V_{DD} is rising
- $V_{LVDDOWN}$ when V_{DD} is falling

The Low Voltage Detector circuitry resets only the MCU and it does not change the external \overline{RESET} pin status: no reset signal for an external application is generated.

Figure 47. Low Voltage Detector Reset Function

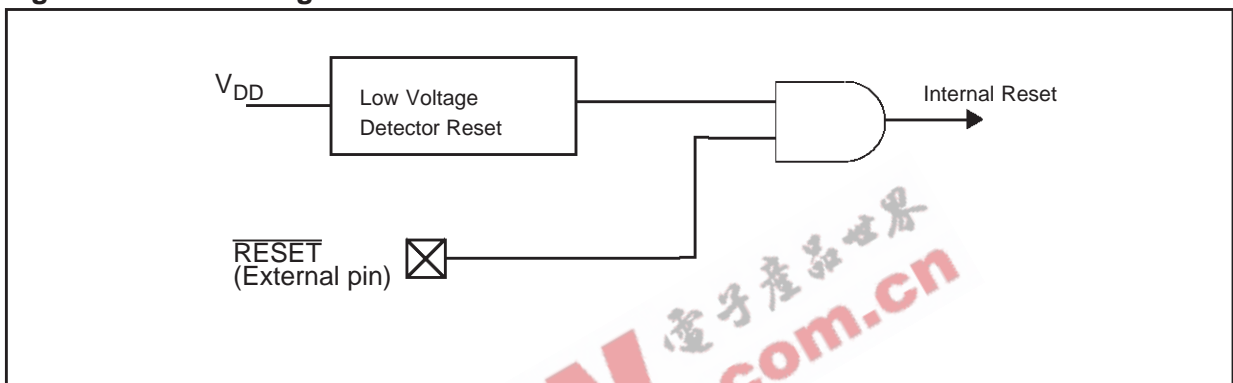
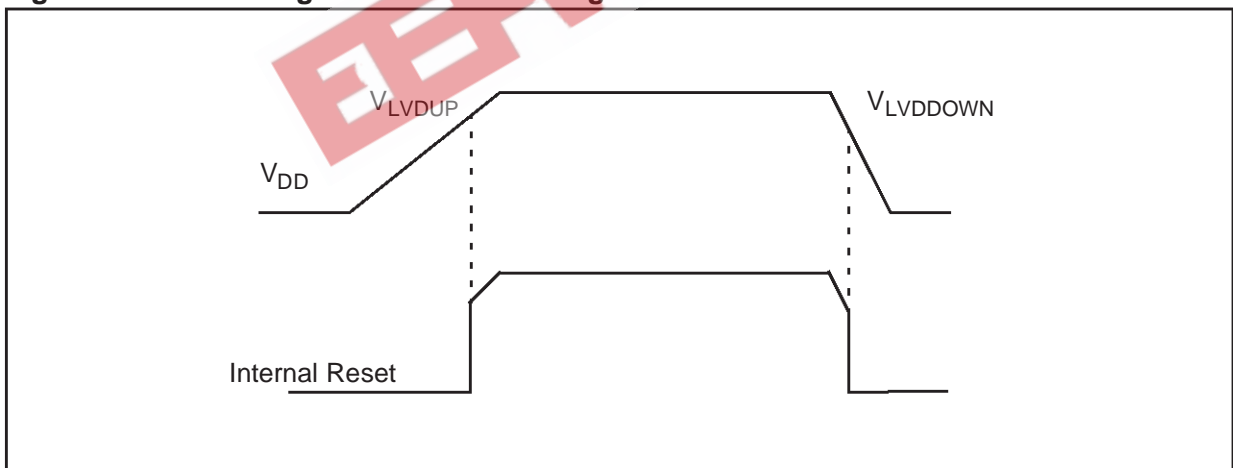

Figure 48. Low Voltage Detector Reset Signal



Note: Refer to Electrical Characteristics for the values of V_{DD} , V_{LVDUP} and $V_{LVDDOWN}$.

6 EXTERNAL MEMORY INTERFACE (EXTMI)

6.1 INTRODUCTION

The ST9 External Memory Interface uses two registers (EMR1 and EMR2) to configure external memory accesses. Some interface signals are also affected by WCR - R252 Page 0.

If the two registers EMR1 and EMR2 are set to the proper values, the ST9+ memory access cycle is similar to that of the original ST9, with the only exception that it is composed of just two system clock phases, named T1 and T2.

During phase T1, the memory address is output on the \overline{AS} falling edge and is valid on the rising edge of \overline{AS} . Port0 and Port 1 maintain the address stable until the following T1 phase.

During phase T2, two forms of behavior are possible. If the memory access is a Read cycle, Port 0 pins are released in high-impedance until the next T1 phase and the data signals are sampled by the ST9 on the rising edge of \overline{DS} . If the memory access is a Write cycle, on the falling edge of \overline{DS} , Port 0 outputs data to be written in the external memory. Those data signals are valid on the rising edge of \overline{DS} and are maintained stable until the next address is output. Note that \overline{DS} is pulled low at the beginning of phase T2 only during an external memory access.

Figure 49. Page 21 Registers

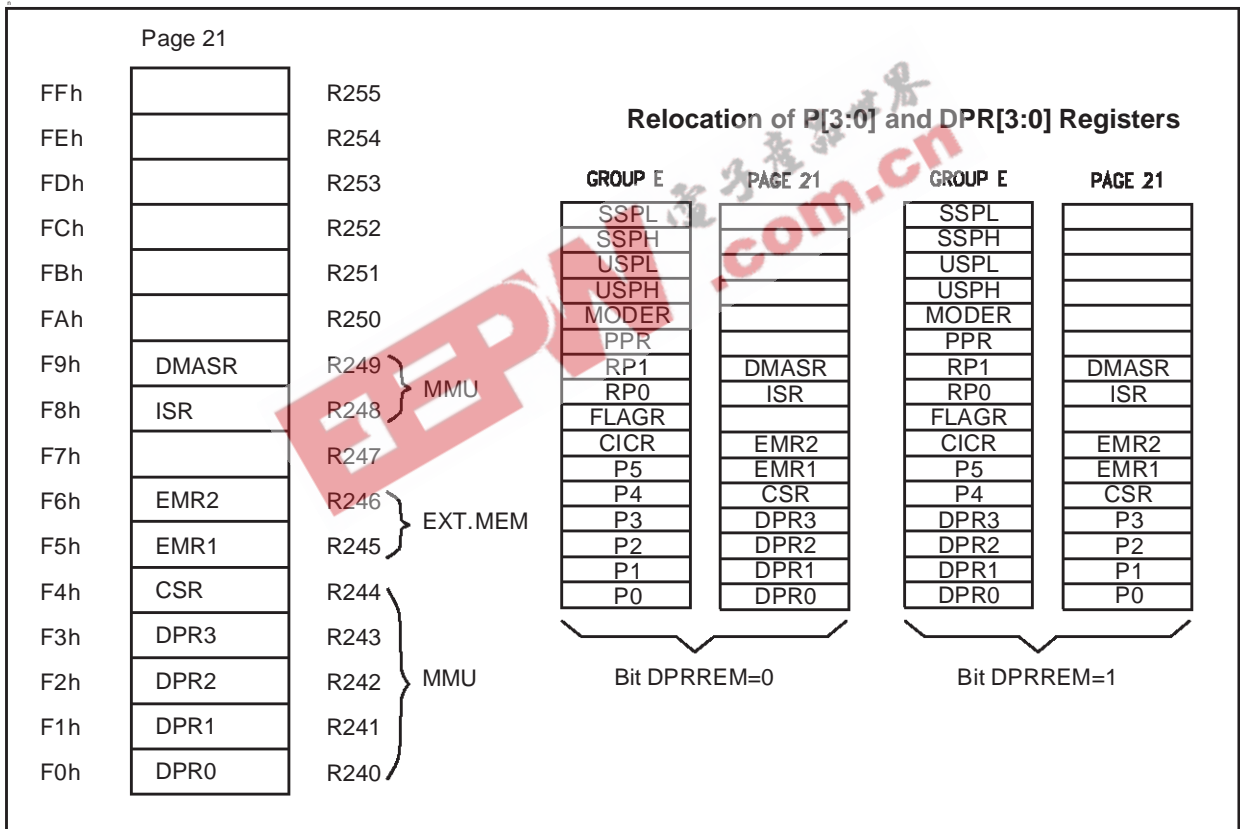

6.2 EXTERNAL MEMORY SIGNALS

The access to external memory is made using the \overline{AS} , \overline{DS} , $\overline{DS2}$, \overline{RW} , Port 0, Port 1, and \overline{WAIT} signals described below.

Refer to Figure 51

6.2.1 \overline{AS} : Address Strobe

\overline{AS} (Output, Active low, Tristate) is active during the System Clock high-level phase of each T1 memory cycle: an \overline{AS} rising edge indicates that Memory Address and Read/Write Memory control signals are valid. \overline{AS} is released in high-impedance during the bus acknowledge cycle or under the processor control by setting the HIMP bit (MODER.0, R235). Depending on the device \overline{AS} is available as Alternate Function or as a dedicated pin.

Under Reset, \overline{AS} is held high with an internal weak pull-up.

The behavior of this signal is affected by the MC, ASAF, ETO, BSZ, LAS[1:0] and UAS[1:0] bits in the EMR1 or EMR2 registers. Refer to the Register description.

6.2.2 \overline{DS} : Data Strobe

\overline{DS} (Output, Active low, Tristate) is active during the internal clock high-level phase of each T2 memory cycle. During an external memory read cycle, the data on Port 0 must be valid before the \overline{DS} rising edge. During an external memory write cycle, the data on Port 0 are output on the falling edge of \overline{DS} and they are valid on the rising edge of \overline{DS} . When the internal memory is accessed \overline{DS} is kept high during the whole memory cycle. \overline{DS} is released in high-impedance during bus acknowledge cycle or

under processor control by setting the HIMP bit (MODER.0, R235). Under Reset status, \overline{DS} is held high with an internal weak pull-up.

The behavior of this signal is affected by the MC, $\overline{DS2EN}$, and BSZ bits in the EMR1 register. Refer to the Register description.

6.2.3 $\overline{DS2}$: Data Strobe 2

This additional Data Strobe pin (Alternate Function Output, Active low, Tristate) is available on some ST9 devices only. It allows two external memories to be connected to the ST9, the upper memory block (A21=1 typically RAM) and the lower memory block (A21=0 typically ROM) without any external logic. The selection between the upper and lower memory blocks depends on the A21 address pin value.

The upper memory block is controlled by the \overline{DS} pin while the lower memory block is controlled by the $\overline{DS2}$ pin. When the internal memory is addressed, $\overline{DS2}$ is kept high during the whole memory cycle. $\overline{DS2}$ is released in high-impedance during bus acknowledge cycle or under processor control by setting the HIMP bit (MODER.0, R235). $\overline{DS2}$ is enabled via software as the Alternate Function output of the associated I/O port bit (refer to specific ST9 version to identify the specific port and pin).

The behavior of this signal is affected by the $\overline{DS2EN}$, and BSZ bits in the EMR1 register. Refer to the Register description.

EXTERNAL MEMORY SIGNALS (Cont'd)

Figure 50. Effects of DS2EN on the behavior of \overline{DS} and $\overline{DS2}$

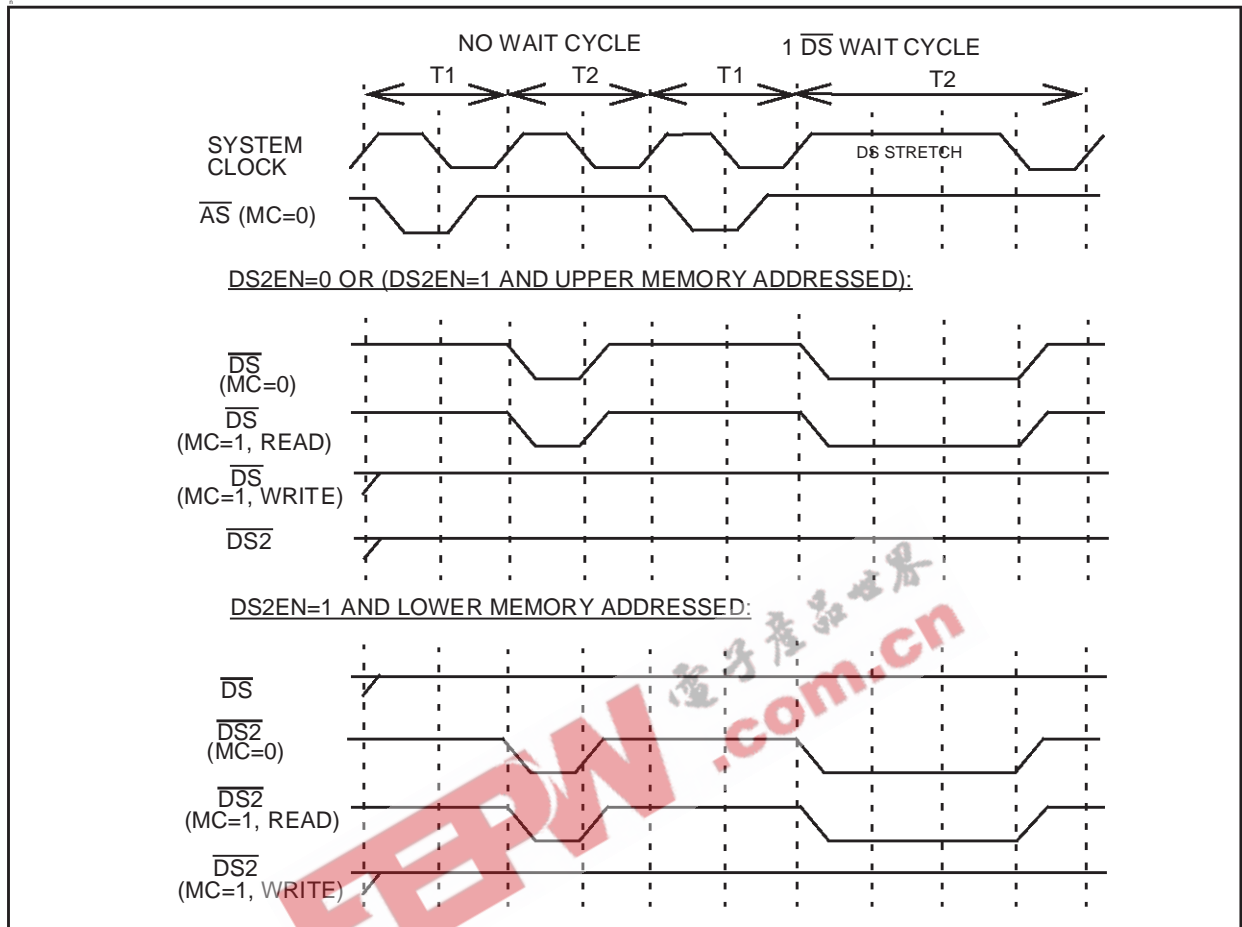

ST92163 - EXTERNAL MEMORY INTERFACE (EXTMI)

EXTERNAL MEMORY SIGNALS (Cont'd)

Figure 51. External memory Read/Write with a programmable wait

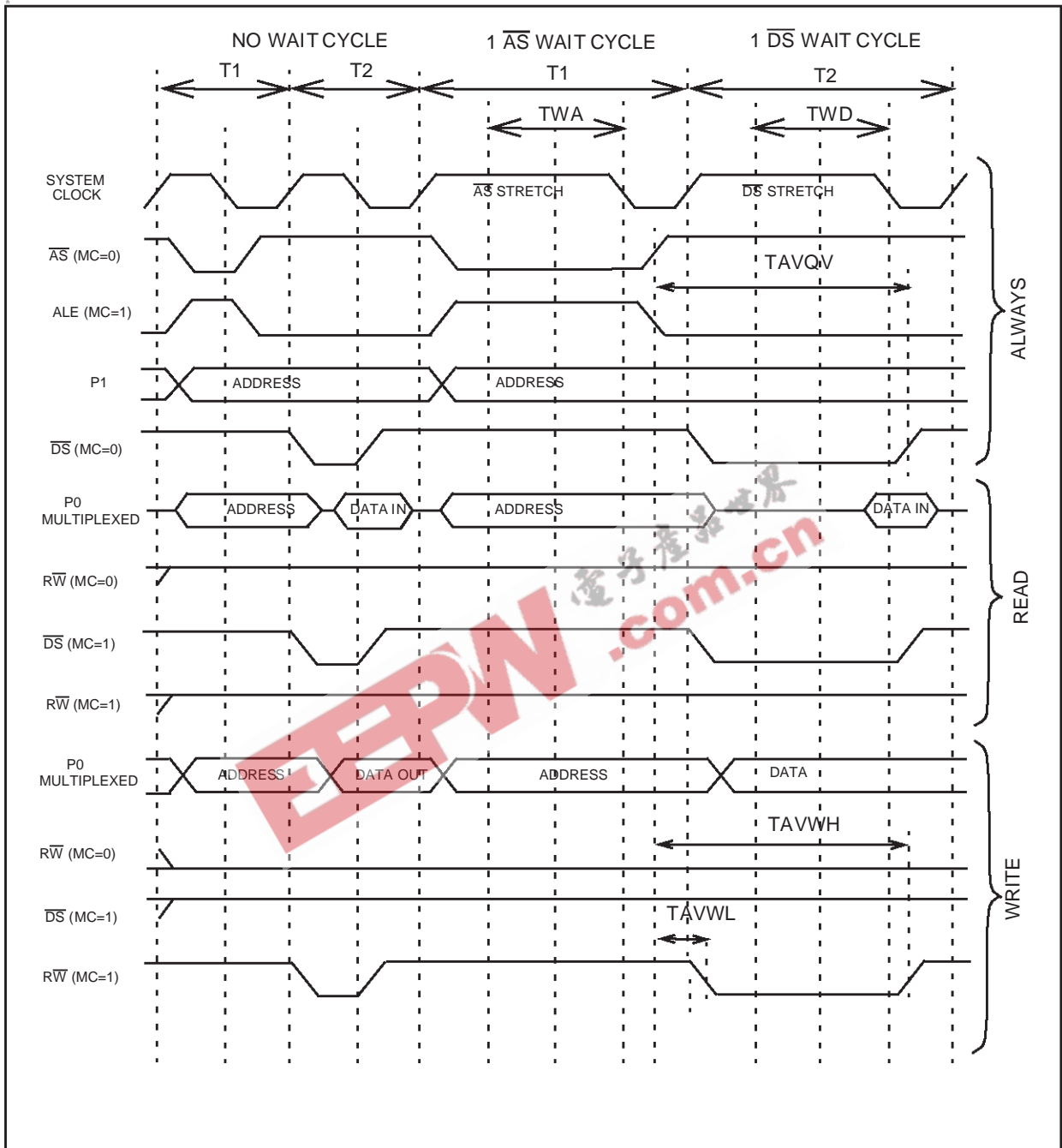

EXTERNAL MEMORY SIGNALS (Cont'd)

6.2.4 \overline{RW} : Read/Write

\overline{RW} (Alternate Function Output, Active low, Tristate) identifies the type of memory cycle: \overline{RW} ="1" identifies a memory read cycle, \overline{RW} ="0" identifies a memory write cycle. It is defined at the beginning of each memory cycle and it remains stable until the following memory cycle. \overline{RW} is released in high-impedance during bus acknowledge cycle or under processor control by setting the HIMP bit (MODER). \overline{RW} is enabled via software as the Alternate Function output of the associated I/O port bit (refer to specific ST9 device to identify the port and pin). Under Reset status, the associated bit of the port is set into bidirectional weak pull-up mode.

The behavior of this signal is affected by the MC, ETO and BSZ bits in the EMR1 register. Refer to the Register description.

6.2.5 \overline{BREQ} , \overline{BACK} : Bus Request, Bus Acknowledge

Note: These pins are available only on some ST9 devices (see Pin description).

\overline{BREQ} (Alternate Function Input, Active low) indicates to the ST9 that a bus request has tried or is trying to gain control of the memory bus. Once enabled by setting the BRQEN bit (MODER.1, R235), \overline{BREQ} is sampled with the falling edge of the processor internal clock during phase T2.

Figure 52. External memory Read/Write sequence with external wait (\overline{WAIT} pin)

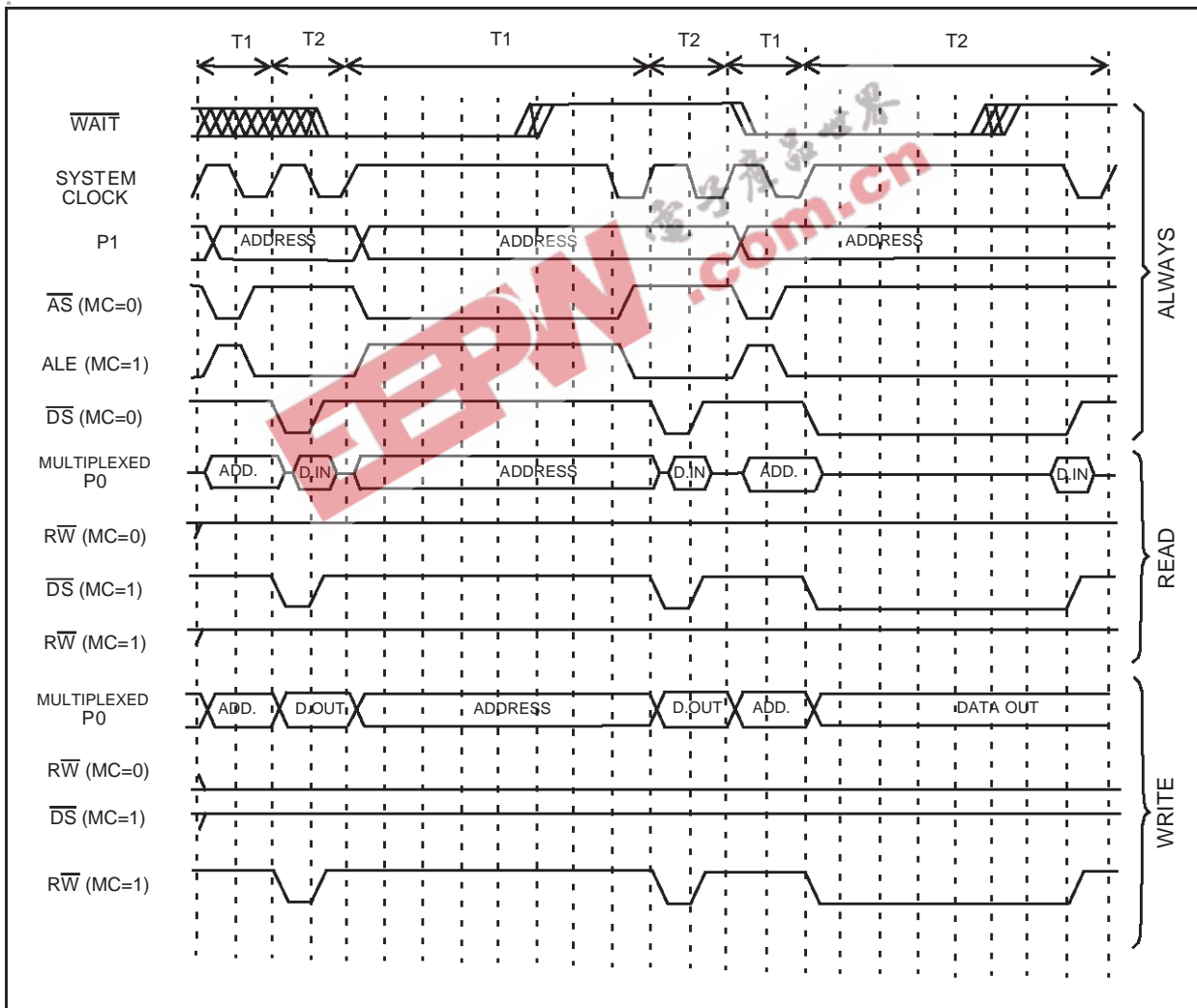

EXTERNAL MEMORY SIGNALS (Cont'd)

Whenever it is sampled low, the System Clock is stretched and the external memory signals (\overline{AS} , \overline{DS} , $\overline{DS2}$, \overline{RW} , P0 and P1) are released in high-impedance. The external memory interface pins are driven again by the ST9 as soon as \overline{BREQ} is sampled high.

\overline{BACK} (Alternate Function Output, Active low) indicates that the ST9 has relinquished control of the memory bus in response to a bus request. \overline{BREQ} is driven low when the external memory interface signals are released in high-impedance.

At MCU reset, the bus request function is disabled. To enable it, configure the I/O port pins assigned to \overline{BREQ} and \overline{BACK} as Alternate Function and set the \overline{BRQEN} bit in the \overline{MODER} register.

6.2.6 PORT 0

If Port 0 (Input/Output, Push-Pull/Open-Drain/Weak Pull-up) is used as a bit programmable parallel I/O port, it has the same features as a regular port. When set as an Alternate Function, it is used as the External Memory interface: it outputs the multiplexed Address 8 LSB: A[7:0] /Data bus D[7:0].

6.2.7 PORT 1

If Port 1 (Input/Output, Push-Pull/Open-Drain/Weak Pull-up) is used as a bit programmable parallel I/O port, it has the same features as a regular port. When set as an Alternate Function, it is used

as the external memory interface to provide the 8 MSB of the address A[15:8].

The behavior of the Port 0 and 1 pins is affected by the \overline{BSZ} and \overline{ETO} bits in the $\overline{EMR1}$ register. Refer to the Register description.

6.2.8 \overline{WAIT} : External Memory Wait

\overline{WAIT} (Alternate Function Input, Active low) indicates to the ST9 that the external memory requires more time to complete the memory access cycle. If bit \overline{EWEN} (\overline{EIVR}) is set, the \overline{WAIT} signal is sampled with the rising edge of the processor internal clock during phase T1 or T2 of every memory cycle. If the signal was sampled active, one more internal clock cycle is added to the memory cycle. On the rising edge of the added internal clock cycle, \overline{WAIT} is sampled again to continue or finish the memory cycle stretching. Note that if \overline{WAIT} is sampled active during phase T1 then \overline{AS} is stretched, while if \overline{WAIT} is sampled active during phase T2 then \overline{DS} is stretched. \overline{WAIT} is enabled via software as the Alternate Function input of the associated I/O port bit (refer to specific ST9 version to identify the specific port and pin). Under Reset status, the associated bit of the port is set to the bidirectional weak pull-up mode. Refer to Figure 52

Figure 53. Application Example

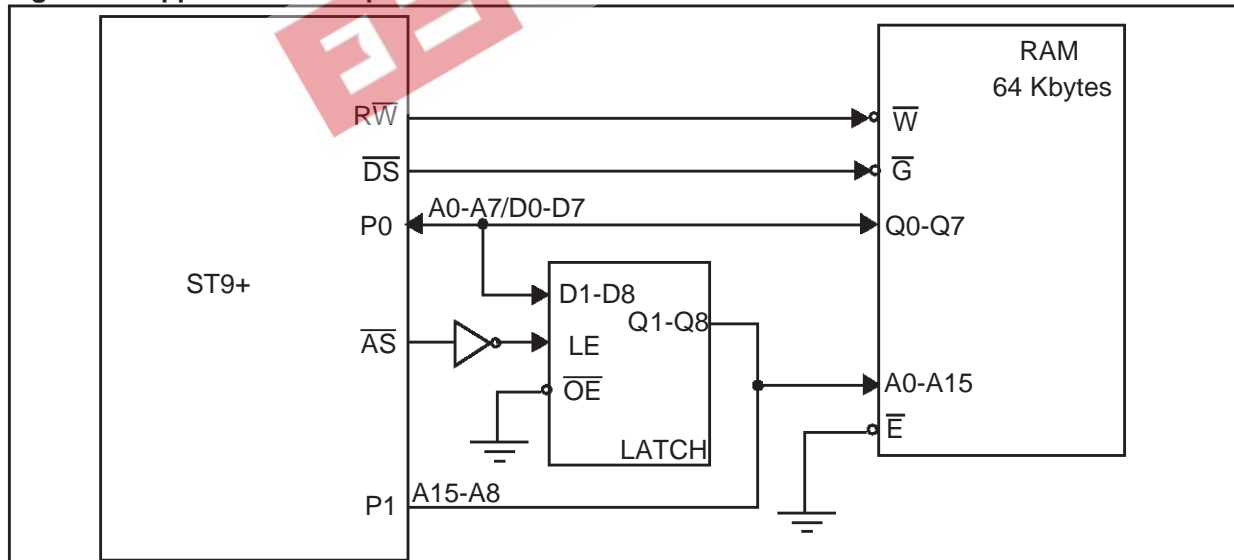

6.3 REGISTER DESCRIPTION

EXTERNAL MEMORY REGISTER 1 (EMR1)

R245 - Read/Write

Register Page: 21

Reset value: 1000 0000 (80h)

7							0
x	MC	DS2EN	ASAF	x	ETO	BSZ	X

Bit 7 = Reserved.

Bit 6 = **MC**: *Mode Control*.

0: \overline{AS} , \overline{DS} and \overline{RW} pins keep the ST9OLD meaning.

1: \overline{AS} pin becomes ALE, Address Load Enable (\overline{AS} inverted); Thus Memory Address, Read/Write signals are valid whenever a falling edge of ALE occurs.

\overline{DS} becomes OEN, Output ENable: it keeps the ST9OLD meaning during external read operations, but is forced to "1" during external write operations.

\overline{RW} pin becomes WEN, Write ENable: it follows the ST9OLD \overline{DS} meaning during external write operations, but is forced to "1" during external read operations.

Bit 5 = **DS2EN**: *Data Strobe 2 enable*.

0: The $\overline{DS2}$ pin is forced to "1" during the whole memory cycle.

1: If the lower memory block is addressed, the $\overline{DS2}$ pin follows the ST9OLD \overline{DS} meaning (if MC=0) or it becomes OEN (if MC=1). The \overline{DS} pin is forced to 1 during the whole memory cycle.

If the upper memory block is used, $\overline{DS2}$ is forced to "1" during the whole memory cycle. The \overline{DS} pin behaviour is not modified.

Refer to Figure 50

Bit 4 = **ASAF**: *Address Strobe as Alternate Function*.

Depending on the device, \overline{AS} can be either a dedicated pin or a port Alternate Function. This bit is used only in the second case.

0: \overline{AS} Alternate function disabled.

1: \overline{AS} Alternate Function enabled.

Bit 2 = **ETO**: *External toggle*.

0: The external memory interface pins (\overline{AS} , \overline{DS} , $\overline{DS2}$, \overline{RW} , Port0, Port1) toggle only if an access to external memory is performed.

1: When the internal memory protection is disabled (mask option available on some devices only), the above pins (except \overline{DS} and $\overline{DS2}$ which never toggle during internal memory accesses) toggle during both internal and external memory accesses.

Bit 1 = **BSZ**: *Bus size*.

0: All the I/O ports including the external memory interface pins use smaller, less noisy output buffers. This may limit the operation frequency of the device, unless the clock is slow enough or sufficient wait states are inserted.

1: All the I/O ports including the external memory interface pins (\overline{AS} , \overline{DS} , $\overline{DS2}$, \overline{RW} , Port 0, 1) use larger, more noisy output buffers.

Bit 0 = Reserved.

WARNING: External memory must be correctly addressed before and after a write operation on the EMR1 register. For example, if code is fetched from external memory using the ST9OLD external memory interface configuration (MC=0), setting the MC bit will cause the device to behave unpredictably.

REGISTER DESCRIPTION (Cont'd)

EXTERNAL MEMORY REGISTER 2 (EMR2)

R246 - Read/Write

Register Page: 21

Reset value: 0000 1111 (0Fh)

7	0
-	-
ENC	DPR
CSR	REM
MEM	MEM
SEL	SEL
LAS	LAS
1	0
UAS	UAS
1	0

Bit 7 = Reserved.

Bit 6 = **ENCSR**: *Enable Code Segment Register.*

This bit affects the ST9 CPU behavior whenever an interrupt request is issued.

- 0: The CPU works in original ST9 compatibility mode concerning stack frame during interrupts. For the duration of the interrupt service routine, ISR is used instead of CSR, and the interrupt stack frame is identical to that of the original ST9: only the PC and Flags are pushed. This avoids saving the CSR on the stack in the event of an interrupt, thus ensuring a faster interrupt response time. The drawback is that it is not possible for an interrupt service routine to perform inter-segment calls or jumps: these instructions would update the CSR, which, in this case, is not used (ISR is used instead). The code segment size for all interrupt service routines is thus limited to 64K bytes.
- 1: If ENCSR is set, ISR is only used to point to the interrupt vector table and to initialize the CSR at the beginning of the interrupt service routine: the old CSR is pushed onto the stack together with the PC and flags, and CSR is then loaded with

the contents of ISR. In this case, ired will also restore CSR from the stack. This approach allows interrupt service routines to access the entire 4Mbytes of address space; the drawback is that the interrupt response time is slightly increased, because of the need to also save CSR on the stack. Full compatibility with the original ST9 is lost in this case, because the interrupt stack frame is different; this difference, however, should not affect the vast majority of programs.

Bit 5 = **DPRREM**: *Data Page Registers remapping*

0: The locations of the four MMU (Memory Management Unit) Data Page Registers (DPR0, DPR1, DPR2 and DPR3) are in page 21.

1: The four MMU Data Page Registers are swapped with that of the Data Registers of ports 0-3.

Refer to Figure 49

Bit 4 = **MEMSEL**: *Memory Selection.*

Warning: Must be set by the user when using the external memory interface (Reset value is 0).

Bit 3:2 = **LAS[1:0]**: *Lower memory address strobe stretch.*

These two bits contain the number of wait cycles (from 0 to 3) to add to the System Clock to stretch AS during external lower memory block accesses (MSB of 22-bit internal address=0). The reset value is 3.

REGISTER DESCRIPTION (Cont'd)

Bit 1:0 = **UAS[1:0]**: *Upper memory address strobe stretch.*

These two bits contain the number of wait cycles (from 0 to 3) to add to the System Clock to stretch \overline{AS} during external upper memory block accesses (MSB of 22-bit internal address=1). The reset value is 3.

WARNING: The EMR2 register cannot be written during an interrupt service routine.

WAIT CONTROL REGISTER (WCR)

R252 - Read/Write

Register Page: 0

Reset Value: 0111 1111 (7Fh)

7							0
0	WDGEN	UDS2	UDS1	UDS0	LDS2	LDS1	LDS0

Bit 7 = Reserved, forced by hardware to 0.

Bit 6 = **WDGEN**: *Watchdog Enable.*

For a description of this bit, refer to the Timer/Watchdog chapter.

WARNING: Clearing this bit has the effect of setting the Timer/Watchdog to Watchdog mode. Unless this is desired, it must be set to "1".

Bit 5:3 = **UDS[2:0]**: *Upper memory data strobe stretch.*

These bits contain the number of INTCLK cycles to be added automatically to \overline{DS} for external upper memory block accesses. UDS = 0 adds no addi-

tional wait cycles. UDS = 7 adds the maximum 7 INTCLK cycles (reset condition).

Bit 2:0 = **LDS[2:0]**: *Lower memory data strobe stretch.*

These bits contain the number of INTCLK cycles to be added automatically to \overline{DS} or $\overline{DS2}$ (depending on the DS2EN bit of the EMR1 register) for external lower memory block accesses. LDS = 0 adds no additional wait cycles, LDS = 7 adds the maximum 7 INTCLK cycles (reset condition).

Note 1: The number of clock cycles added refers to INTCLK and NOT to CPUCLK.

Note 2: The distinction between the Upper memory block and the Lower memory block allows different wait cycles between the first 2 Mbytes and the second 2 Mbytes, and allows 2 different data strobe signals to be used to access 2 different memories.

Typically, the RAM will be located above address 0x200000 and the ROM below address 0x1FFFFFF, with different access times. No extra hardware is required as \overline{DS} is used to access the upper memory block and $\overline{DS2}$ is used to access the lower memory block.

WARNING: The reset value of the Wait Control Register gives the maximum number of Wait cycles for external memory. To get optimum performance from the ST9, the user should write the UDS[2:0] and LDS[2:0] bits to 0, if the external addressed memories are fast enough.

7 I/O PORTS

7.1 INTRODUCTION

ST9 devices feature flexible individually programmable multifunctional input/output lines. Refer to the Pin Description Chapter for specific pin allocations. These lines, which are logically grouped as 8-bit ports, can be individually programmed to provide digital input/output and analog input, or to connect input/output signals to the on-chip peripherals as alternate pin functions. All ports can be individually configured as an input, bi-directional, output or alternate function. In addition, pull-ups can be turned off for open-drain operation, and weak pull-ups can be turned on in their place, to avoid the need for off-chip resistive pull-ups. Ports configured as open drain must never have voltage on the port pin exceeding V_{DD} (refer to the Electrical Characteristics section). Input buffers can be either TTL or CMOS compatible. Alternatively some input buffers can be permanently forced by hardware to operate as Schmitt triggers.

7.2 SPECIFIC PORT CONFIGURATIONS

Refer to the Pin Description chapter for a list of the specific port styles and reset values.

7.3 PORT CONTROL REGISTERS

Each port is associated with a Data register (PxDR) and three Control registers (PxC0, PxC1, PxC2). These define the port configuration and allow dynamic configuration changes during program execution. Port Data and Control registers are mapped into the Register File as shown in Figure 54. Port Data and Control registers are treated just like any other general purpose register. There are no special instructions for port manipulation: any instruction that can address a register, can address the ports. Data can be directly accessed in the port register, without passing through other memory or “accumulator” locations.

Figure 54. I/O Register Map

GROUP E			GROUP F PAGE 2			GROUP F PAGE 3			GROUP F PAGE 43		
			FFh	Reserved	P7DR		P9DR	R255			
			FEh	P3C2	P7C2		P9C2	R254			
			FDh	P3C1	P7C1		P9C1	R253			
			FCh	P3C0	P7C0		P9C0	R252			
			FBh	Reserved	P6DR		P8DR	R251			
			FAh	P2C2	P6C2		P8C2	R250			
			F9h	P2C1	P6C1		P8C1	R249			
			F8h	P2C0	P6C0		P8C0	R248			
			F7h	Reserved	Reserved			R247			
			F6h	P1C2	P5C2			R246			
E5h	P5DR	R229	F5h	P1C1	P5C1			R245			
E4h	P4DR	R228	F4h	P1C0	P5C0		Reserved	R244			
E3h	P3DR	R227	F3h	Reserved	Reserved			R243			
E2h	P2DR	R226	F2h	P0C2	P4C2			R242			
E1h	P1DR	R225	F1h	P0C1	P4C1			R241			
E0h	P0DR	R224	F0h	P0C0	P4C0			R240			

PORT CONTROL REGISTERS (Cont'd)

During Reset, ports with weak pull-ups are set in bidirectional/weak pull-up mode and the output Data Register is set to FFh. This condition is also held after Reset, except for Ports 0 and 1 in ROM-less devices, and can be redefined under software control.

Bidirectional ports without weak pull-ups are set in high impedance during reset. To ensure proper levels during reset, these ports must be externally connected to either V_{DD} or V_{SS} through external pull-up or pull-down resistors.

Other reset conditions may apply in specific ST9 devices.

7.4 INPUT/OUTPUT BIT CONFIGURATION

By programming the control bits $PxC0.n$ and $PxC1.n$ (see Figure 55) it is possible to configure bit $Px.n$ as Input, Output, Bidirectional or Alternate Function Output, where X is the number of the I/O port, and n the bit within the port ($n = 0$ to 7).

When programmed as input, it is possible to select the input level as TTL or CMOS compatible by programming the relevant $PxC2.n$ control bit, except where the Schmitt trigger option is assigned to the pin.

The output buffer can be programmed as push-pull or open-drain.

A weak pull-up configuration can be used to avoid external pull-ups when programmed as bidirectional (except where the weak pull-up option has

been permanently disabled in the pin hardware assignment).

Each pin of an I/O port may assume software programmable Alternate Functions (refer to the device Pin Description and to Section 7.5). To output signals from the ST9 peripherals, the port must be configured as AF OUT. On ST9 devices with A/D Converter(s), configure the ports used for analog inputs as AF IN.

The basic structure of the bit $Px.n$ of a general purpose port Px is shown in Figure 56.

Independently of the chosen configuration, when the user addresses the port as the destination register of an instruction, the port is written to and the data is transferred from the internal Data Bus to the Output Master Latches. When the port is addressed as the source register of an instruction, the port is read and the data (stored in the Input Latch) is transferred to the internal Data Bus.

When $Px.n$ is programmed as an Input:
(See Figure 57).

- The Output Buffer is forced tristate.
- The data present on the I/O pin is sampled into the Input Latch at the beginning of each instruction execution.
- The data stored in the Output Master Latch is copied into the Output Slave Latch at the end of the execution of each instruction. Thus, if bit $Px.n$ is reconfigured as an Output or Bidirectional, the data stored in the Output Slave Latch will be reflected on the I/O pin.

INPUT/OUTPUT BIT CONFIGURATION (Cont'd)

Figure 55. Control Bits

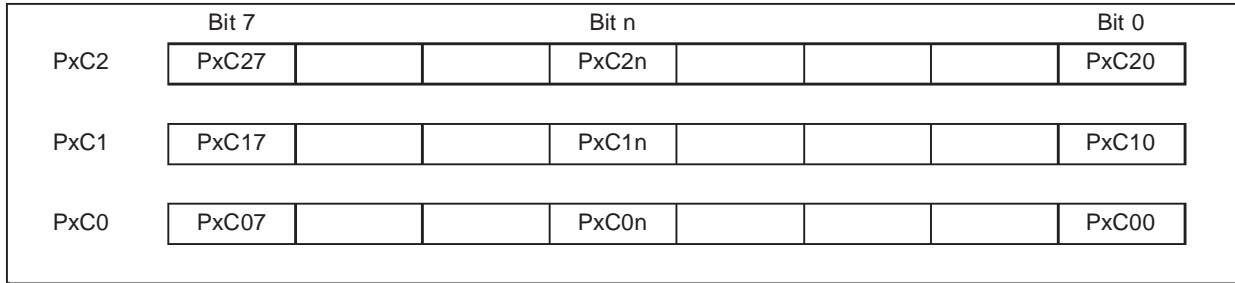

Table 18. Port Bit Configuration Table (n = 0, 1... 7; X = port number)

	General Purpose I/O Pins								A/D Pins
PXC2n	0	1	0	1	0	1	0	1	1
PXC1n	0	0	1	1	0	0	1	1	1
PXC0n	0	0	0	0	1	1	1	1	1
PXn Configuration	BID	BID	OUT	OUT	IN	IN	AF OUT	AF OUT	AF IN
PXn Output Type	WP OD	OD	PP	OD	HI-Z	HI-Z	PP	OD	HI-Z ⁽¹⁾
PXn Input Type	TTL (or Schmitt Trigger)	TTL (or Schmitt Trigger)	TTL (or Schmitt Trigger)	TTL (or Schmitt Trigger)	CMOS (or Schmitt Trigger)	TTL (or Schmitt Trigger)	TTL (or Schmitt Trigger)	TTL (or Schmitt Trigger)	Analog Input

⁽¹⁾ For A/D Converter inputs.

Legend:

- X = Port
- n = Bit
- AF = Alternate Function
- BID = Bidirectional
- CMOS= CMOS Standard Input Levels
- HI-Z = High Impedance
- IN = Input
- OD = Open Drain
- OUT = Output
- PP = Push-Pull
- TTL = TTL Standard Input Levels
- WP = Weak Pull-up

INPUT/OUTPUT BIT CONFIGURATION (Cont'd)

Figure 56. Basic Structure of an I/O Port Pin

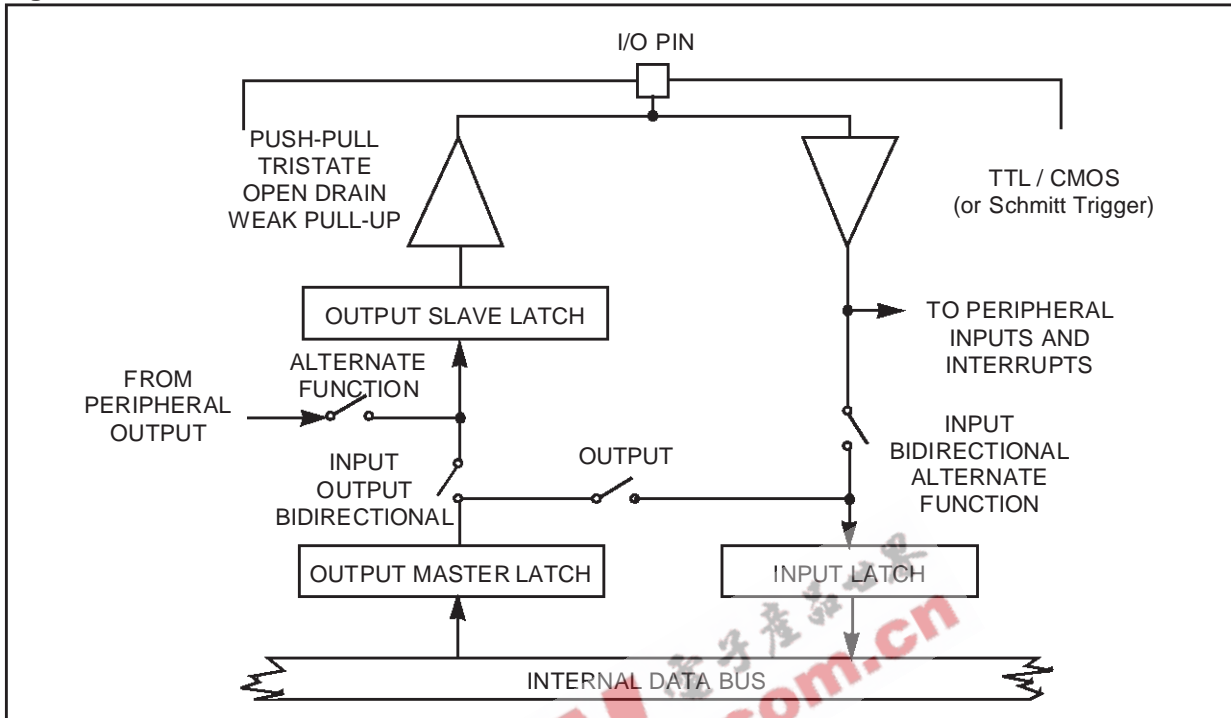

Figure 57. Input Configuration

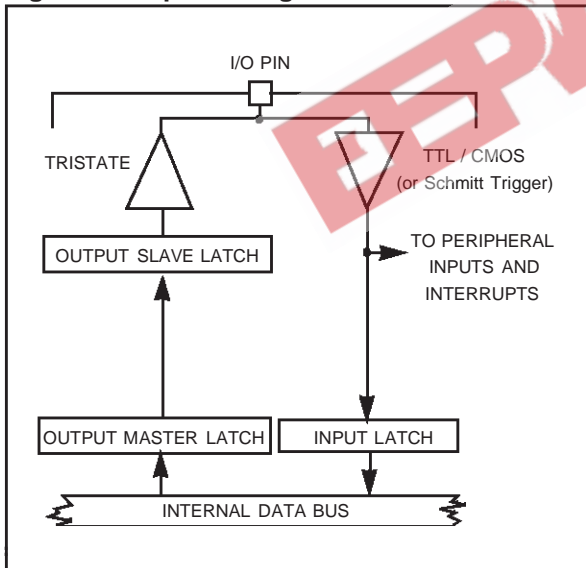
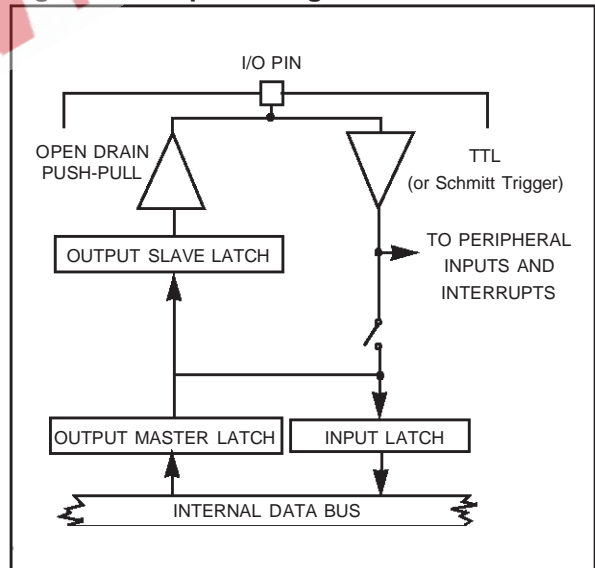

Figure 58. Output Configuration



INPUT/OUTPUT BIT CONFIGURATION (Cont'd)

When Px.n is programmed as an Output:
(Figure 58)

- The Output Buffer is turned on in an Open-drain or Push-pull configuration.
- The data stored in the Output Master Latch is copied both into the Input Latch and into the Output Slave Latch, driving the I/O pin, at the end of the execution of the instruction.

When Px.n is programmed as Bidirectional:
(Figure 59)

- The Output Buffer is turned on in an Open-Drain or Weak Pull-up configuration (except when disabled in hardware).
- The data present on the I/O pin is sampled into the Input Latch at the beginning of the execution of the instruction.
- The data stored in the Output Master Latch is copied into the Output Slave Latch, driving the I/O pin, at the end of the execution of the instruction.

WARNING: Due to the fact that in bidirectional mode the external pin is read instead of the output latch, particular care must be taken with arithmetic/logic and Boolean instructions performed on a bidirectional port pin.

These instructions use a read-modify-write sequence, and the result written in the port register depends on the logical level present on the external pin.

This may bring unwanted modifications to the port output register content.

For example:

Port register content, 0Fh
external port value, 03h
(Bits 3 and 2 are externally forced to 0)

A bset instruction on bit 7 will return:

Port register content, 83h
external port value, 83h
(Bits 3 and 2 have been cleared).

To avoid this situation, it is suggested that all operations on a port, using at least one bit in bidirectional mode, are performed on a copy of the port register, then transferring the result with a load instruction to the I/O port.

When Px.n is programmed as a digital Alternate Function Output:
(Figure 60)

- The Output Buffer is turned on in an Open-Drain or Push-Pull configuration.

- The data present on the I/O pin is sampled into the Input Latch at the beginning of the execution of the instruction.
- The signal from an on-chip function is allowed to load the Output Slave Latch driving the I/O pin. Signal timing is under control of the alternate function. If no alternate function is connected to Px.n, the I/O pin is driven to a high level when in Push-Pull configuration, and to a high impedance state when in open drain configuration.

Figure 59. Bidirectional Configuration

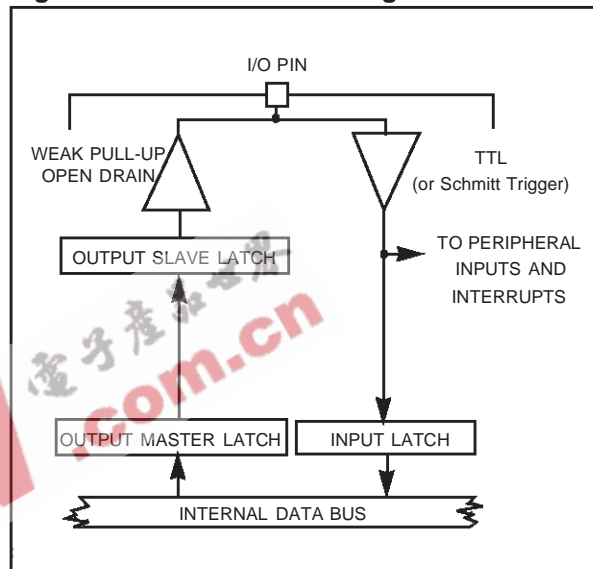
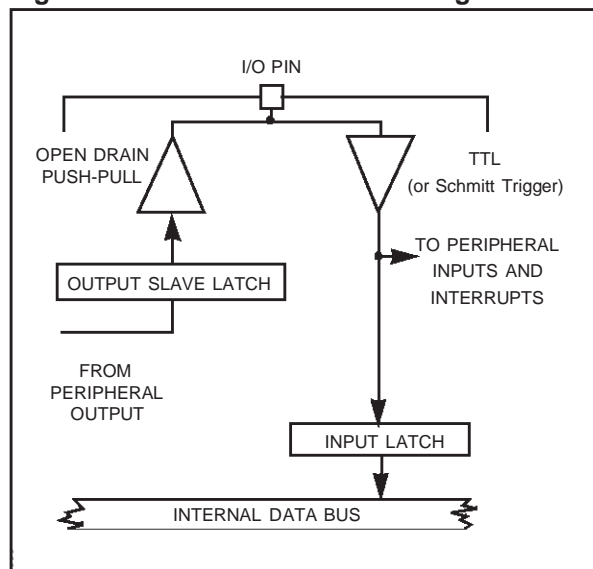

Figure 60. Alternate Function Configuration



7.5 ALTERNATE FUNCTION ARCHITECTURE

Each I/O pin may be connected to three different types of internal signal:

- Data bus Input/Output
- Alternate Function Input
- Alternate Function Output

7.5.1 Pin Declared as I/O

A pin declared as I/O, is connected to the I/O buffer. This pin may be an Input, an Output, or a bidirectional I/O, depending on the value stored in (PxC2, PxC1 and PxC0).

7.5.2 Pin Declared as an Alternate Input

A single pin may be directly connected to several Alternate inputs. In this case, the user must select the required input mode (with the PxC2, PxC1, PxC0 bits) and enable the selected Alternate Function in the Control Register of the peripheral. No specific port configuration is required to enable an Alternate Function input, since the input buffer is directly connected to each alternate function module on the shared pin. As more than one module can use the same input, it is up to the user software to enable the required module as necessary. Parallel I/Os remain operational even when using an Alternate Function input. The exception to this is when an I/O port bit is permanently assigned by hardware as an A/D bit. In this case, after software programming of the bit in AF-OD-TTL, the Alternate function output is forced to logic level 1. The analog voltage level on the corresponding pin is directly input to the A/D.

7.5.3 Pin Declared as an Alternate Function Output

The user must select the AF OUT configuration using the PxC2, PxC1, PxC0 bits. Several Alternate Function outputs may drive a common pin. In

such case, the Alternate Function output signals are logically ANDed before driving the common pin. The user must therefore enable the required Alternate Function Output by software.

WARNING: When a pin is connected both to an alternate function output and to an alternate function input, it should be noted that the output signal will always be present on the alternate function input.

7.6 I/O STATUS AFTER WFI, HALT AND RESET

The status of the I/O ports during the Wait For Interrupt, Halt and Reset operational modes is shown in the following table. The External Memory Interface ports are shown separately. If only the internal memory is being used and the ports are acting as I/O, the status is the same as shown for the other I/O ports.

Mode	Ext. Mem - I/O Ports		I/O Ports
	P0	P1, P2, P6	
WFI	High Impedance or next address (depending on the last memory operation performed on Port)	Next Address	Not Affected (clock outputs running)
HALT	High Impedance	Next Address	Not Affected (clock outputs stopped)
RESET	Alternate function push-pull (ROMless device)		Bidirectional Weak Pull-up (High impedance when disabled in hardware).

8 ON-CHIP PERIPHERALS

8.1 TIMER/WATCHDOG (WDT)

Important Note: This chapter is a generic description of the WDT peripheral. However depending on the ST9 device, some or all of WDT interface signals described may not be connected to external pins. For the list of WDT pins present on the ST9 device, refer to the device pinout description in the first section of the data sheet.

8.1.1 Introduction

The Timer/Watchdog (WDT) peripheral consists of a programmable 16-bit timer and an 8-bit prescaler. It can be used, for example, to:

- Generate periodic interrupts
- Measure input signal pulse widths
- Request an interrupt after a set number of events
- Generate an output signal waveform
- Act as a Watchdog timer to monitor system integrity

The main WDT registers are:

- Control register for the input, output and interrupt logic blocks (WDTCR)
- 16-bit counter register pair (WDTHR, WDTLR)
- Prescaler register (WDTPR)

The hardware interface consists of up to five signals:

- WDIN External clock input
- WDOUT Square wave or PWM signal output
- INT0 External interrupt input
- NMI Non-Maskable Interrupt input
- HW0SW1 Hardware/Software Watchdog enable.

Figure 61. Timer/Watchdog Block Diagram

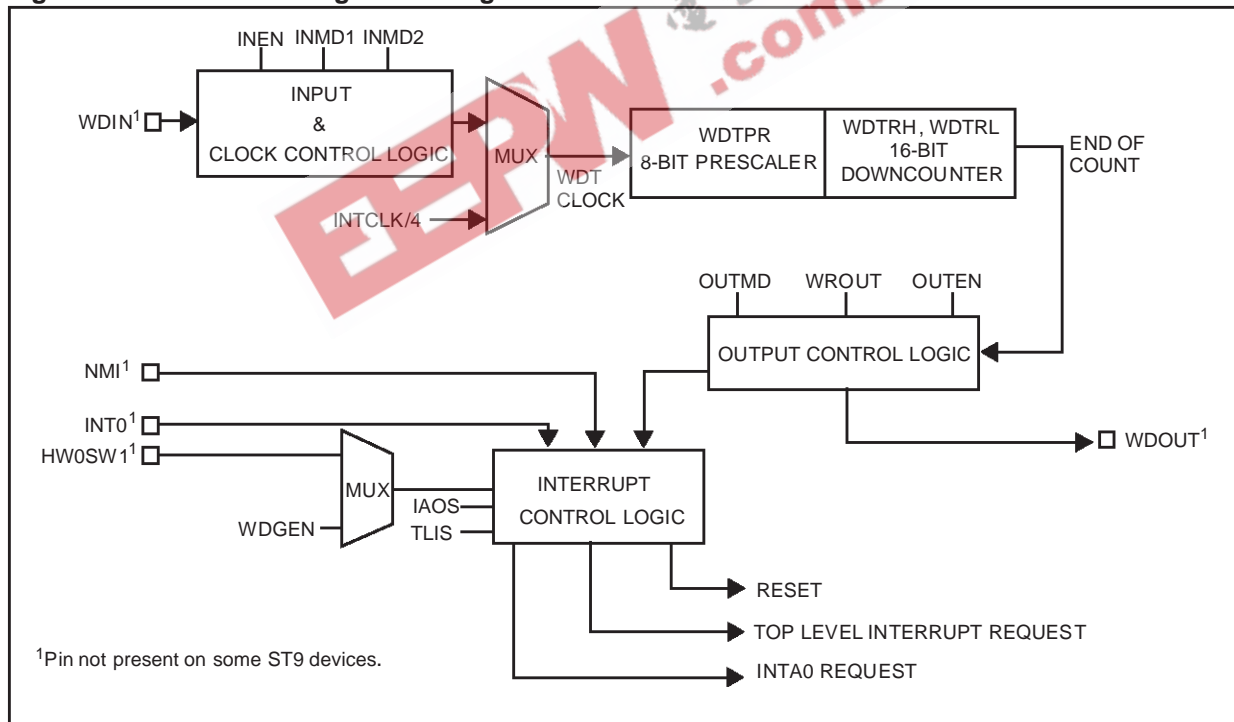

TIMER/WATCHDOG (Cont'd)**8.1.2 Functional Description****8.1.2.1 External Signals**

The HW0SW1 pin can be used to permanently enable Watchdog mode. Refer to Section 0.1.3.1.

The WDIN Input pin can be used in one of four modes:

- Event Counter Mode
- Gated External Input Mode
- Triggerable Input Mode
- Retriggerable Input Mode

The WDOOUT output pin can be used to generate a square wave or a Pulse Width Modulated signal.

An interrupt, generated when the WDT is running as the 16-bit Timer/Counter, can be used as a Top Level Interrupt or as an interrupt source connected to channel A0 of the external interrupt structure (replacing the INTO interrupt input).

The counter can be driven either by an external clock, or internally by INTCLK divided by 4.

8.1.2.2 Initialisation

The prescaler (WDTPR) and counter (WDTRL, WDTRH) registers must be loaded with initial values before starting the Timer/Counter. If this is not done, counting will start with reset values.

8.1.2.3 Start/Stop

The ST_SP bit enables downcounting. When this bit is set, the Timer will start at the beginning of the following instruction. Resetting this bit stops the counter.

If the counter is stopped and restarted, counting will resume from the last value unless a new constant has been entered in the Timer registers (WDTRL, WDTRH).

A new constant can be written in the WDTRH, WDTRL, WDTPR registers while the counter is running. The new value of the WDTRH, WDTRL registers will be loaded at the next End of Count (EOC) condition while the new value of the WDTPR register will be effective immediately.

End of Count is when the counter is 0.

When Watchdog mode is enabled the state of the ST_SP bit is irrelevant.

8.1.2.4 Single/Continuous Mode

The S_C bit allows selection of single or continuous mode. This Mode bit can be written with the Timer stopped or running. It is possible to toggle the S_C bit and start the counter with the same instruction.

Single Mode

On reaching the End Of Count condition, the Timer stops, reloads the constant, and resets the Start/Stop bit. Software can check the current status by reading this bit. To restart the Timer, set the Start/Stop bit.

Note: If the Timer constant has been modified during the stop period, it is reloaded at start time.

Continuous Mode

On reaching the End Of Count condition, the counter automatically reloads the constant and restarts. It is stopped only if the Start/Stop bit is reset.

8.1.2.5 Input Section

If the Timer/Counter input is enabled (INEN bit) it can count pulses input on the WDIN pin. Otherwise it counts the internal clock/4.

For instance, when INTCLK = 20MHz, the End Of Count rate is:

3.35 seconds for Maximum Count
(Timer Const. = FFFFh, Prescaler Const. = FFh)

200 ns for Minimum Count
(Timer Const. = 0000h, Prescaler Const. = 00h)

The Input pin can be used in one of four modes:

- Event Counter Mode
- Gated External Input Mode
- Triggerable Input Mode
- Retriggerable Input Mode

The mode is configurable in the WDTCCR.

8.1.2.6 Event Counter Mode

In this mode the Timer is driven by the external clock applied to the input pin, thus operating as an event counter. The event is defined as a high to low transition of the input signal. Spacing between trailing edges should be at least 8 INTCLK periods (or 400ns with INTCLK = 20MHz).

Counting starts at the next input event after the ST_SP bit is set and stops when the ST_SP bit is reset.

TIMER/WATCHDOG (Cont'd)

8.1.2.7 Gated Input Mode

This mode can be used for pulse width measurement. The Timer is clocked by INTCLK/4, and is started and stopped by means of the input pin and the ST_SP bit. When the input pin is high, the Timer counts. When it is low, counting stops. The maximum input pin frequency is equivalent to INTCLK/8.

8.1.2.8 Triggable Input Mode

The Timer (clocked internally by INTCLK/4) is started by the following sequence:

- setting the Start-Stop bit, followed by
- a High to Low transition on the input pin.

To stop the Timer, reset the ST_SP bit.

8.1.2.9 Retriggerable Input Mode

In this mode, the Timer (clocked internally by INTCLK/4) is started by setting the ST_SP bit. A High to Low transition on the input pin causes counting to restart from the initial value. When the Timer is stopped (ST_SP bit reset), a High to Low transition of the input pin has no effect.

8.1.2.10 Timer/Counter Output Modes

Output modes are selected by means of the OUTEN (Output Enable) and OUTMD (Output Mode) bits of the WDTCCR register.

No Output Mode (OUTEN = "0")

The output is disabled and the corresponding pin is set high, in order to allow other alternate functions to use the I/O pin.

Square Wave Output Mode (OUTEN = "1", OUTMD = "0")

The Timer outputs a signal with a frequency equal to half the End of Count repetition rate on the WDOOUT pin. With an INTCLK frequency of 20MHz, this allows a square wave signal to be generated whose period can range from 400ns to 6.7 seconds.

Pulse Width Modulated Output Mode (OUTEN = "1", OUTMD = "1")

The state of the WROUT bit is transferred to the output pin (WDOOUT) at the End of Count, and is held until the next End of Count condition. The user can thus generate PWM signals by modifying the status of the WROUT pin between End of Count events, based on software counters decremented by the Timer Watchdog interrupt.

8.1.3 Watchdog Timer Operation

This mode is used to detect the occurrence of a software fault, usually generated by external interference or by unforeseen logical conditions, which causes the application program to abandon its normal sequence of operation. The Watchdog, when enabled, resets the MCU, unless the program executes the correct write sequence before expiry of the programmed time period. The application program must be designed so as to correctly write to the WDTLR Watchdog register at regular intervals during all phases of normal operation.

8.1.3.1 Hardware Watchdog/Software Watchdog

The HW0SW1 pin (when available) selects Hardware Watchdog or Software Watchdog.

If HW0SW1 is held low:

- The Watchdog is enabled by hardware immediately after an external reset. (Note: Software reset or Watchdog reset have no effect on the Watchdog enable status).
- The initial counter value (FFFFh) cannot be modified, however software can change the prescaler value on the fly.
- The WDGEN bit has no effect. (Note: it is not forced low).

If HW0SW1 is held high, or is not present:

- The Watchdog can be enabled by resetting the WDGEN bit.

8.1.3.2 Starting the Watchdog

In Watchdog mode the Timer is clocked by INTCLK/4.

If the Watchdog is software enabled, the time base must be written in the timer registers before entering Watchdog mode by resetting the WDGEN bit. Once reset, this bit cannot be changed by software.

If the Watchdog is hardware enabled, the time base is fixed by the reset value of the registers.

Resetting WDGEN causes the counter to start, regardless of the value of the Start-Stop bit.

In Watchdog mode, only the Prescaler Constant may be modified.

If the End of Count condition is reached a System Reset is generated.

TIMER/WATCHDOG (Cont'd)

8.1.3.3 Preventing Watchdog System Reset

In order to prevent a system reset, the sequence AAh, 55h must be written to WDTLR (Watchdog Timer Low Register). Once 55h has been written, the Timer reloads the constant and counting restarts from the preset value.

To reload the counter, the two writing operations must be performed sequentially without inserting other instructions that modify the value of the WDTLR register between the writing operations. The maximum allowed time between two reloads of the counter depends on the Watchdog timeout period.

8.1.3.4 Non-Stop Operation

In Watchdog Mode, a Halt instruction is regarded as illegal. Execution of the Halt instruction stops further execution by the CPU and interrupt acknowledgment, but does not stop INTCLK, CPU-CLK or the Watchdog Timer, which will cause a System Reset when the End of Count condition is reached. Furthermore, ST_SP, S_C and the Input Mode selection bits are ignored. Hence, regardless of their status, the counter always runs in Continuous Mode, driven by the internal clock.

The Output mode should not be enabled, since in this context it is meaningless.

Figure 62. Watchdog Timer Mode

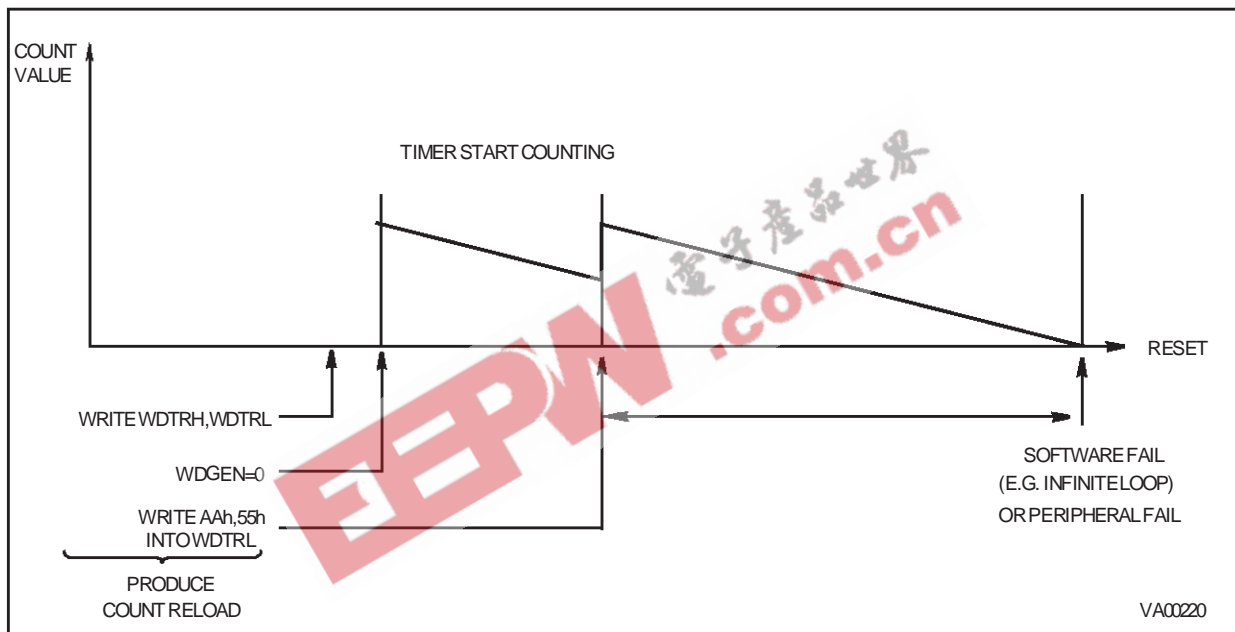

TIMER/WATCHDOG (Cont'd)

8.1.4 WDT Interrupts

The Timer/Watchdog issues an interrupt request at every End of Count, when this feature is enabled.

A pair of control bits, IA0S (EIVR.1, Interrupt A0 selection bit) and TLIS (EIVR.2, Top Level Input Selection bit) allow the selection of 2 interrupt sources (Timer/Watchdog End of Count, or External Pin) handled in two different ways, as a Top Level Non Maskable Interrupt (Software Reset), or as a source for channel A0 of the external interrupt logic.

A block diagram of the interrupt logic is given in Figure 3.

Note: Software traps can be generated by setting the appropriate interrupt pending bit.

Table 1 below, shows all the possible configurations of interrupt/reset sources which relate to the Timer/Watchdog.

A reset caused by the watchdog will set bit 6, WDGRES of R242 - Page 55 (Clock Flag Register). See section CLOCK CONTROL REGISTERS.

Figure 63. Interrupt Sources

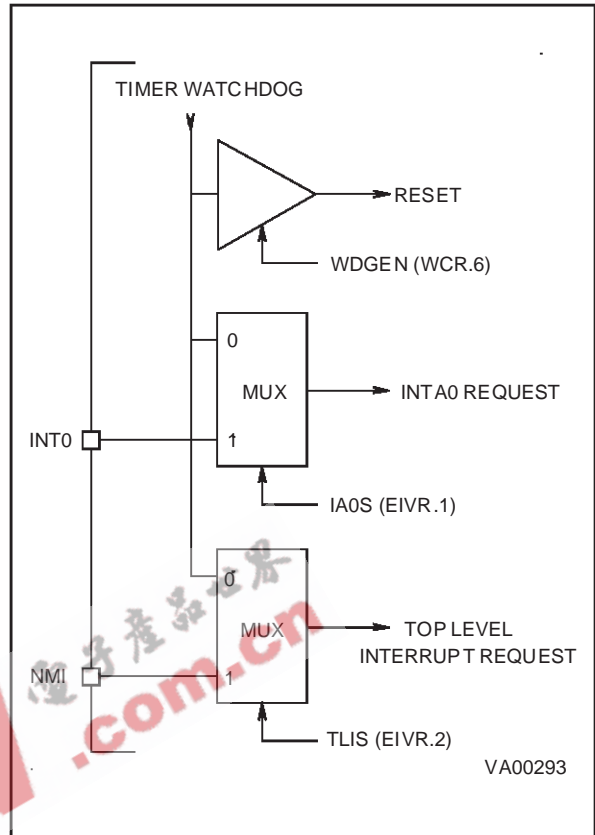

Table 19. Interrupt Configuration

Control Bits			Enabled Sources			Operating Mode
WDGEN	IA0S	TLIS	Reset	INTA0	Top Level	
0	0	0	WDG/Ext Reset	SW TRAP	SW TRAP	Watchdog
0	0	1	WDG/Ext Reset	SW TRAP	Ext Pin	Watchdog
0	1	0	WDG/Ext Reset	Ext Pin	SW TRAP	Watchdog
0	1	1	WDG/Ext Reset	Ext Pin	Ext Pin	Watchdog
1	0	0	Ext Reset	Timer	Timer	Timer
1	0	1	Ext Reset	Timer	Ext Pin	Timer
1	1	0	Ext Reset	Ext Pin	Timer	Timer
1	1	1	Ext Reset	Ext Pin	Ext Pin	Timer

Legend:

WDG = Watchdog function
 SW TRAP = Software Trap

Note: If IA0S and TLIS = 0 (enabling the Watchdog EOC as interrupt source for both Top Level and INTA0 interrupts), only the INTA0 interrupt is taken into account.

TIMER/WATCHDOG (Cont'd)

8.1.5 Register Description

The Timer/Watchdog is associated with 4 registers mapped into Group F, Page 0 of the Register File.

WDTHR: Timer/Watchdog High Register

WDTLR: Timer/Watchdog Low Register

WDTPR: Timer/Watchdog Prescaler Register

WDTCR: Timer/Watchdog Control Register

Three additional control bits are mapped in the following registers on Page 0:

Watchdog Mode Enable, (WCR.6)

Top Level Interrupt Selection, (EIVR.2)

Interrupt A0 Channel Selection, (EIVR.1)

Note: The registers containing these bits also contain other functions. Only the bits relevant to the operation of the Timer/Watchdog are shown here.

Counter Register

This 16 bit register (WDTLR, WDTHR) is used to load the 16 bit counter value. The registers can be read or written "on the fly".

TIMER/WATCHDOG HIGH REGISTER (WDTHR)

R248 - Read/Write

Register Page: 0

Reset value: 1111 1111 (FFh)

7							0
R15	R14	R13	R12	R11	R10	R9	R8

Bit 7:0 = **R[15:8]** Counter *Most Significant Bits*.

TIMER/WATCHDOG LOW REGISTER (WDTLR)

R249 - Read/Write

Register Page: 0

Reset value: 1111 1111b (FFh)

7							0
R7	R6	R5	R4	R3	R2	R1	R0

Bit 7:0 = **R[7:0]** Counter *Least Significant Bits*.

TIMER/WATCHDOG PRESCALER REGISTER (WDTPR)

R250 - Read/Write

Register Page: 0

Reset value: 1111 1111 (FFh)

7							0
PR7	PR6	PR5	PR4	PR3	PR2	PR1	PR0

Bit 7:0 = **PR[7:0]** *Prescaler value*.

A programmable value from 1 (00h) to 256 (FFh).

Warning: In order to prevent incorrect operation of the Timer/Watchdog, the prescaler (WDTPR) and counter (WDTRL, WDTRH) registers must be initialised before starting the Timer/Watchdog. If this is not done, counting will start with the reset (un-initialised) values.

WATCHDOG TIMER CONTROL REGISTER (WDTCR)

R251 - Read/Write

Register Page: 0

Reset value: 0001 0010 (12h)

7							0
ST_SP	S_C	INMD1	INMD2	INEN	OUTMD	WROUT	OUTEN

Bit 7 = **ST_SP:** *Start/Stop Bit*.

This bit is set and cleared by software.

0: Stop counting

1: Start counting (see Warning above)

Bit 6 = **S_C:** *Single/Continuous*.

This bit is set and cleared by software.

0: Continuous Mode

1: Single Mode

Bit 5:4 = **INMD[1:2]:** *Input mode selection bits*.

These bits select the input mode:

INMD1	INMD2	INPUT MODE
0	0	Event Counter
0	1	Gated Input (Reset value)
1	0	Triggerable Input
1	1	Retriggerable Input

TIMER/WATCHDOG (Cont'd)

Bit 3 = **INEN**: *Input Enable*.
 This bit is set and cleared by software.
 0: Disable input section
 1: Enable input section

Bit 2 = **OUTMD**: *Output Mode*.
 This bit is set and cleared by software.
 0: The output is toggled at every End of Count
 1: The value of the WROUT bit is transferred to the output pin on every End Of Count if OUTEN=1.

Bit 1 = **WROUT**: *Write Out*.
 The status of this bit is transferred to the Output pin when OUTMD is set; it is user definable to allow PWM output (on Reset WROUT is set).

Bit 0 = **OUTEN**: *Output Enable bit*.
 This bit is set and cleared by software.
 0: Disable output
 1: Enable output

WAIT CONTROL REGISTER (WCR)

R252 - Read/Write
 Register Page: 0
 Reset value: 0111 1111 (7Fh)

7	0							
x	WDGEN	x	x	x	x	x	x	x

Bit 6 = **WDGEN**: *Watchdog Enable* (active low).
 Resetting this bit via software enters the Watchdog mode. Once reset, it cannot be set anymore by the user program. At System Reset, the Watchdog mode is disabled.

Note: This bit is ignored if the Hardware Watchdog option is enabled by pin HW0SW1 (if available).

EXTERNAL INTERRUPT VECTOR REGISTER (EIVR)

R246 - Read/Write
 Register Page: 0
 Reset value: xxxx 0110 (x6h)

7	0						
x	x	x	x	x	TLIS	IAOS	x

Bit 2 = **TLIS**: *Top Level Input Selection*.
 This bit is set and cleared by software.
 0: Watchdog End of Count is TL interrupt source
 1: NMI is TL interrupt source

Bit 1 = **IAOS**: *Interrupt Channel A0 Selection*.
 This bit is set and cleared by software.
 0: Watchdog End of Count is INTA0 source
 1: External Interrupt pin is INTA0 source

Warning: To avoid spurious interrupt requests, the IAOS bit should be accessed only when the interrupt logic is disabled (i.e. after the DI instruction). It is also necessary to clear any possible interrupt pending requests on channel A0 before enabling this interrupt channel. A delay instruction (e.g. a NOP instruction) must be inserted between the reset of the interrupt pending bit and the IAOS write instruction.

Other bits are described in the Interrupt section.

8.2 MULTIFUNCTION TIMER (MFT)

8.2.1 Introduction

The Multifunction Timer (MFT) peripheral offers powerful timing capabilities and features 12 operating modes, including automatic PWM generation and frequency measurement.

The MFT comprises a 16-bit Up/Down counter driven by an 8-bit programmable prescaler. The input clock may be INTCLK/3 or an external source. The timer features two 16-bit Comparison Registers, and two 16-bit Capture/Load/Reload Registers. Two input pins and two alternate function output pins are available.

Several functional configurations are possible, for instance:

- 2 input captures on separate external lines, and 2 independent output compare functions with the counter in free-running mode, or 1 output compare at a fixed repetition rate.

- 1 input capture, 1 counter reload and 2 independent output compares.
- 2 alternate autoreloads and 2 independent output compares.
- 2 alternate captures on the same external line and 2 independent output compares at a fixed repetition rate.

When two timers are present in an ST9 device, a combined operating mode is available.

An internal On-Chip Event signal can be used on some devices to control other on-chip peripherals.

The two external inputs may be individually programmed to detect any of the following:

- rising edges
- falling edges
- both rising and falling edges

Figure 64. MFT Simplified Block Diagram

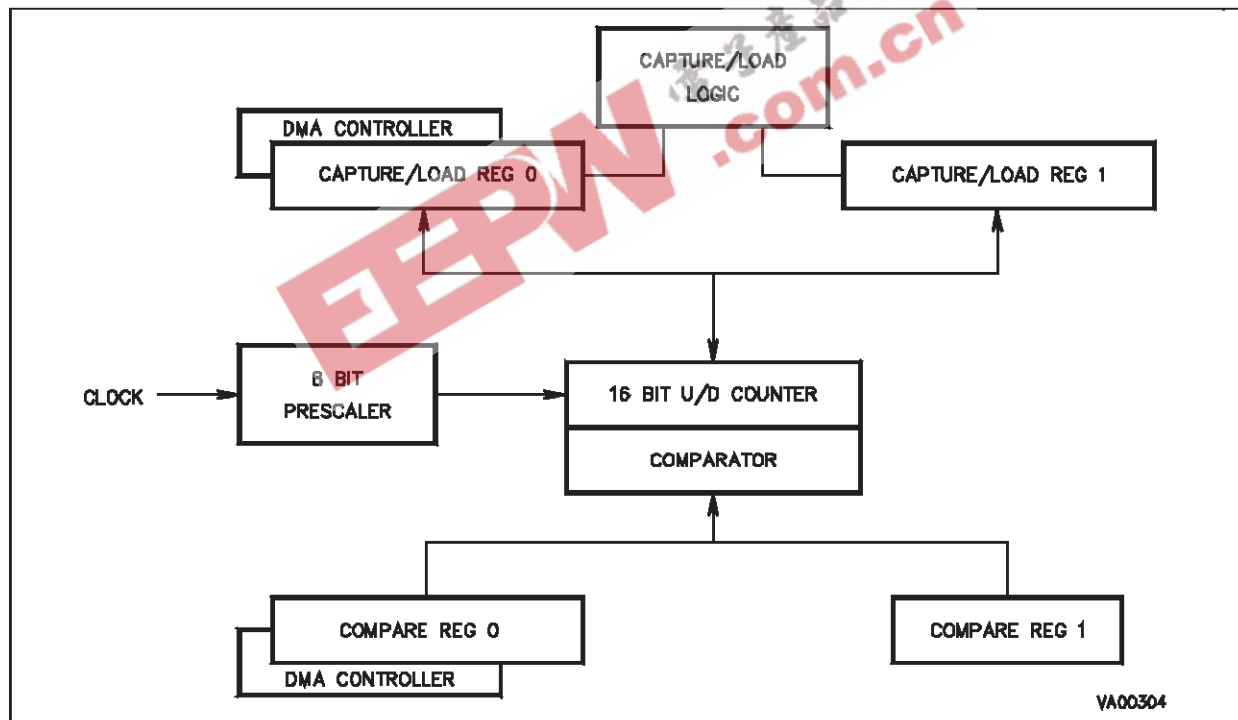

ST92163 - MULTIFUNCTION TIMER (MFT)

MULTIFUNCTION TIMER (Cont'd)

The configuration of each input is programmed in the Input Control Register.

Each of the two output pins can be driven from any of three possible sources:

- Compare Register 0 logic
- Compare Register 1 logic
- Overflow/Underflow logic

Each of these three sources can cause one of the following four actions, independently, on each of the two outputs:

- Nop, Set, Reset, Toggle

In addition, an additional On-Chip Event signal can be generated by two of the three sources mentioned above, i.e. Over/Underflow event and Compare 0 event. This signal can be used internally to

synchronise another on-chip peripheral. Five maskable interrupt sources referring to an End Of Count condition, 2 input captures and 2 output compares, can generate 3 different interrupt requests (with hardware fixed priority), pointing to 3 interrupt routine vectors.

Two independent DMA channels are available for rapid data transfer operations. Each DMA request (associated with a capture on the REG0R register, or with a compare on the CMP0R register) has priority over an interrupt request generated by the same source.

A SWAP mode is also available to allow high speed continuous transfers (see Interrupt and DMA chapter).

Figure 65. Detailed Block Diagram

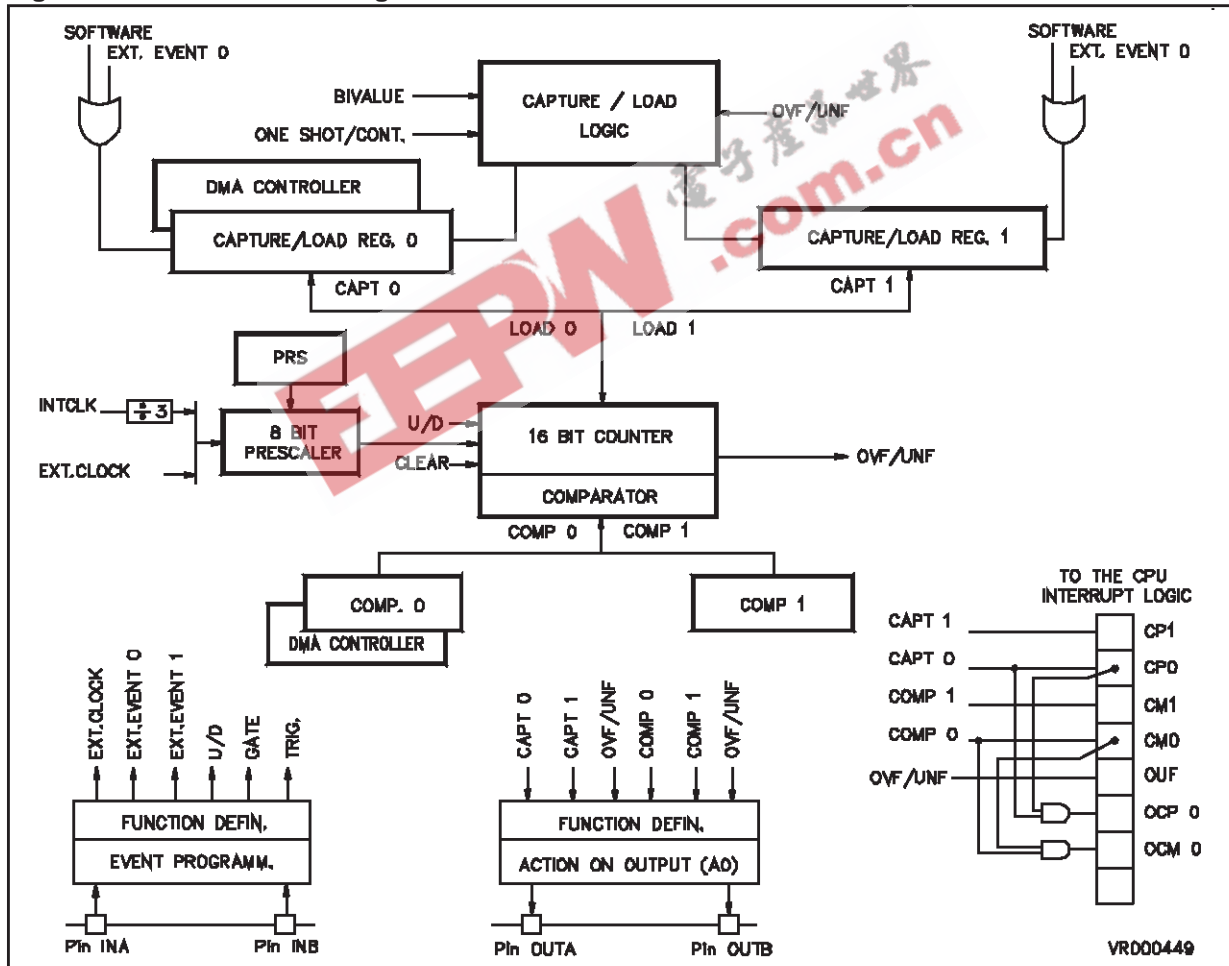

MULTIFUNCTION TIMER (Cont'd)**8.2.2 Functional Description**

The MFT operating modes are selected by programming the Timer Control Register (TCR) and the Timer Mode Register (TMR).

8.2.2.1 Trigger Events

A trigger event may be generated by software (by setting either the CP0 or the CP1 bits in the T_FLAGR register) or by an external source which may be programmed to respond to the rising edge, the falling edge or both by programming bits A0-A1 and B0-B1 in the T_ICR register. This trigger event can be used to perform a capture or a load, depending on the Timer mode (configured using the bits in Table 4).

An event on the TxINA input or setting the CP0 bit triggers a capture to, or a load from the REG0R register (except in Bicapture mode, see Section 0.1.2.11).

An event on the TxINB input or setting the CP1 bit triggers a capture to, or a load from the REG1R register.

In addition, in the special case of "Load from REG0R and monitor on REG1R", it is possible to use the TxINB input as a trigger for REG0R."

8.2.2.2 One Shot Mode

When the counter generates an overflow (in up-count mode), or an underflow (in down-count mode), that is to say when an End Of Count condition is reached, the counter stops and no counter reload occurs. The counter may only be restarted by an external trigger on TxINA or B or a by software trigger on CP0 only. One Shot Mode is entered by setting the CO bit in TMR.

8.2.2.3 Continuous Mode

Whenever the counter reaches an End Of Count condition, the counting sequence is automatically restarted and the counter is reloaded from REG0R (or from REG1R, when selected in Biload Mode). Continuous Mode is entered by resetting the CO bit in TMR.

8.2.2.4 Triggered And Retriggered Modes

A triggered event may be generated by software (by setting either the CP0 or the CP1 bit in the

T_FLAGR register), or by an external source which may be programmed to respond to the rising edge, the falling edge or both, by programming bits A0-A1 and B0-B1 in T_ICR.

In One Shot and Triggered Mode, every trigger event arriving before an End Of Count, is masked. In One Shot and Retriggered Mode, every trigger received while the counter is running, automatically reloads the counter from REG0R. Triggered/Retriggered Mode is set by the REN bit in TMR.

The TxINA input refers to REG0R and the TxINB input refers to REG1R.

WARNING. If the Triggered Mode is selected when the counter is in Continuous Mode, every trigger is disabled, it is not therefore possible to synchronise the counting cycle by hardware or software.

8.2.2.5 Gated Mode

In this mode, counting takes place only when the external gate input is at a logic low level. The selection of TxINA or TxINB as the gate input is made by programming the IN0-IN3 bits in T_ICR.

8.2.2.6 Capture Mode

The REG0R and REG1R registers may be independently set in Capture Mode by setting RM0 or RM1 in TMR, so that a capture of the current count value can be performed either on REG0R or on REG1R, initiated by software (by setting CP0 or CP1 in the T_FLAGR register) or by an event on the external input pins.

WARNING. Care should be taken when two software captures are to be performed on the same register. In this case, at least one instruction must be present between the first CP0/CP1 bit set and the subsequent CP0/CP1 bit reset instructions.

8.2.2.7 Up/Down Mode

The counter can count up or down depending on the state of the UDC bit (Up/Down Count) in TCR, or on the configuration of the external input pins, which have priority over UDC (see Input pin assignment in T_ICR). The UDCS bit returns the counter up/down current status (see also the Up/Down Autodiscrimination mode in the Input Pin Assignment Section).

MULTIFUNCTION TIMER (Cont'd)

8.2.2.8 Free Running Mode

The timer counts continuously (in up or down mode) and the counter value simply overflows or underflows through FFFFh or zero; there is no End Of Count condition as such, and no reloading takes place. This mode is automatically selected either in Bicapture Mode or by setting REGOR for a capture function (Continuous Mode must also be set). In Autoclear Mode, free running operation can be had, with the possibility of choosing a maximum count value before overflow or underflow which is less than 2^{16} (see Autoclear Mode).

8.2.2.9 Monitor Mode

When the RM1 bit in TMR is reset, and the timer is not in Bivalue Mode, REG1R acts as a monitor, duplicating the current up or down counter contents, thus allowing the counter to be read “on the fly”.

8.2.2.10 Autoclear Mode

A clear command forces the counter either to 0000h or to FFFFh, depending on whether up-counting or downcounting is selected. The counter reset may be obtained either directly, through the CCL bit in TCR, or by entering the Autoclear Mode, through the CCP0 and CCMP0 bits in TCR.

Every capture performed on REG0R (if CCP0 is set), or every successful compare performed by CMP0R (if CCMP0 is set), clears the counter and reloads the prescaler.

The Clear On Capture mode allows direct measurement of delta time between successive captures on REGOR, while the Clear On Compare mode allows free running with the possibility of choosing a maximum count value before overflow or underflow which is less than 2^{16} (see Free Running Mode).

8.2.2.11 Bivalue Mode

Depending on the value of the RM0 bit in TMR, the Biload Mode (RM0 reset) or the Bicapture Mode (RM0 set) can be selected as illustrated in Figure 1 below:

Table 20. Bivalue Modes

TMR bits			Timer Operating Modes
RM0	RM1	BM	
0	X	1	BiLoad mode
1	X	1	BiCapture Mode

A) Biload Mode

The Biload Mode is entered by selecting the Bivalue Mode (BM set in TMR) and programming REGOR as a reload register (RM0 reset in TMR).

At any End Of Count, counter reloading is performed alternately from REGOR and REG1R, (a low level for BM bit always sets REGOR as the current register, so that, after a Low to High transition of BM bit, the first reload is always from REGOR).

MULTIFUNCTION TIMER (Cont'd)

Every software or external trigger event on REG0R performs a reload from REG0R resetting the Biloard cycle. In One Shot mode (reload initiated by software or by an external trigger), reloading is always from REG0R.

B) Bicapture Mode

The Bicapture Mode is entered by selecting the Bi-value Mode (the BM bit in TMR is set) and by programming REG0R as a capture register (the RM0 bit in TMR is set).

Every capture event, software simulated (by setting the CP0 flag) or coming directly from the TxINA input line, captures the current counter value alternately into REG0R and REG1R. When the BM bit is reset, REG0R is the current register, so that the first capture, after resetting the BM bit, is always into REG0R.

8.2.2.12 Parallel Mode

When two timers are present on an ST9 device, the parallel mode is entered when the ECK bit in the TMR register of Timer 1 is set. The Timer 1 prescaler input is internally connected to the Timer 0 prescaler output. Timer 0 prescaler input is connected to the system clock line.

By loading the Prescaler Register of Timer 1 with the value 00h the two timers (Timer 0 and Timer 1) are driven by the same frequency in parallel mode. In this mode the clock frequency may be divided by a factor in the range from 1 to 2^{16} .

8.2.2.13 Autodiscriminator Mode

The phase difference sign of two overlapping pulses (respectively on TxINB and TxINA) generates a one step up/down count, so that the up/down control and the counter clock are both external. The setting of the UDC bit in the TCR register has no effect in this configuration.

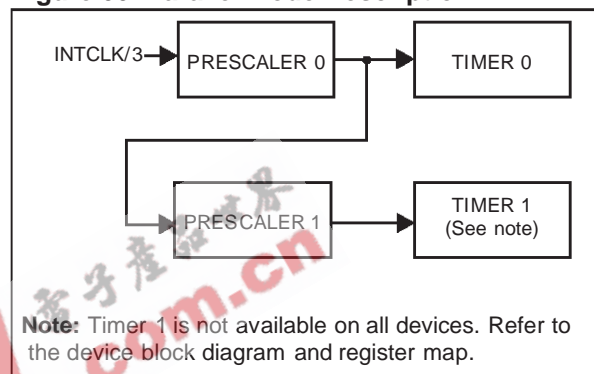
Figure 66. Parallel Mode Description

MULTIFUNCTION TIMER (Cont'd)

8.2.3 Input Pin Assignment

The two external inputs (TxINA and TxINB) of the timer can be individually configured to catch a particular external event (i.e. rising edge, falling edge, or both rising and falling edges) by programming the two relevant bits (A0, A1 and B0, B1) for each input in the external Input Control Register (T_ICR).

The 16 different functional modes of the two external inputs can be selected by programming bits IN0 - IN3 of the T_ICR, as illustrated in Figure 2

Table 21. Input Pin Function

I C Reg. IN3-IN0 bits	TxINA Input Function	TxINB Input Function
0000	not used	not used
0001	not used	Trigger
0010	Gate	not used
0011	Gate	Trigger
0100	not used	Ext. Clock
0101	Trigger	not used
0110	Gate	Ext. Clock
0111	Trigger	Trigger
1000	Clock Up	Clock Down
1001	Up/Down	Ext. Clock
1010	Trigger Up	Trigger Down
1011	Up/Down	not used
1100	Autodiscr.	Autodiscr.
1101	Trigger	Ext. Clock
1110	Ext. Clock	Trigger
1111	Trigger	Gate

Some choices relating to the external input pin assignment are defined in conjunction with the RM0 and RM1 bits in TMR.

For input pin assignment codes which use the input pins as Trigger Inputs (except for code 1010, Trigger Up:Trigger Down), the following conditions apply:

- a trigger signal on the TxINA input pin performs an U/D counter load if RM0 is reset, or an external capture if RM0 is set.
- a trigger signal on the TxINB input pin always performs an external capture on REG1R. The TxINB input pin is disabled when the Bivalue Mode is set.

Note: For proper operation of the External Input pins, the following must be observed:

- the minimum external clock/trigger pulse width must not be less than the system clock (INTCLK) period if the input pin is programmed as rising or falling edge sensitive.
- the minimum external clock/trigger pulse width must not be less than the prescaler clock period (INTCLK/3) if the input pin is programmed as rising and falling edge sensitive (valid also in Auto discrimination mode).
- the minimum delay between two clock/trigger pulse active edges must be greater than the prescaler clock period (INTCLK/3), while the minimum delay between two consecutive clock/trigger pulses must be greater than the system clock (INTCLK) period.
- the minimum gate pulse width must be at least twice the prescaler clock period (INTCLK/3).
- in Autodiscrimination mode, the minimum delay between the input pin A pulse edge and the edge of the input pin B pulse, must be at least equal to the system clock (INTCLK) period.
- if a number, N, of external pulses must be counted using a Compare Register in External Clock mode, then the Compare Register must be loaded with the value $[X \pm (N-1)]$, where X is the starting counter value and the sign is chosen depending on whether Up or Down count mode is selected.

MULTIFUNCTION TIMER (Cont'd)

8.2.3.1 TxINA = I/O - TxINB = I/O

Input pins A and B are not used by the Timer. The counter clock is internally generated and the up/down selection may be made only by software via the UDC (Software Up/Down) bit in the TCR register.

8.2.3.2 TxINA = I/O - TxINB = Trigger

The signal applied to input pin B acts as a trigger signal on REG1R register. The prescaler clock is internally generated and the up/down selection may be made only by software via the UDC (Software Up/Down) bit in the TCR register.

8.2.3.3 TxINA = Gate - TxINB = I/O

The signal applied to input pin A acts as a gate signal for the internal clock (i.e. the counter runs only when the gate signal is at a low level). The counter clock is internally generated and the up/down control may be made only by software via the UDC (Software Up/Down) bit in the TCR register.

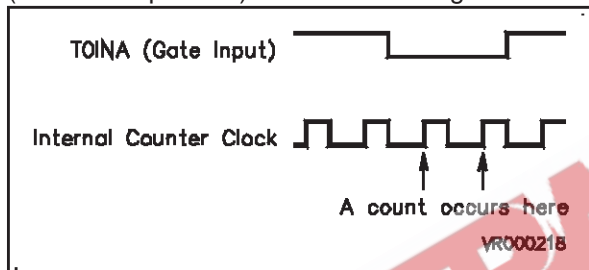

8.2.3.4 TxINA = Gate - TxINB = Trigger

Both input pins A and B are connected to the timer, with the resulting effect of combining the actions relating to the previously described configurations.

8.2.3.5 TxINA = I/O - TxINB = Ext. Clock

The signal applied to input pin B is used as the external clock for the prescaler. The up/down selection may be made only by software via the UDC (Software Up/Down) bit in the TCR register.

8.2.3.6 TxINA = Trigger - TxINB = I/O

The signal applied to input pin A acts as a trigger for REG0R, initiating the action for which the register was programmed (i.e. a reload or capture).

The prescaler clock is internally generated and the up/down selection may be made only by software via the UDC (Software Up/Down) bit in the TCR register.

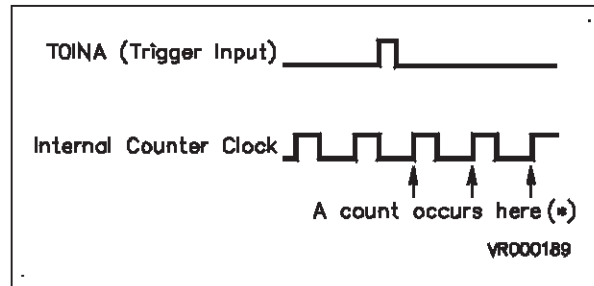

(*) The timer is in One shot mode and REGOR in Reload mode

8.2.3.7 TxINA = Gate - TxINB = Ext. Clock

The signal applied to input pin B, gated by the signal applied to input pin A, acts as external clock for the prescaler. The up/down control may be made only by software action through the UDC bit in the TCR register.

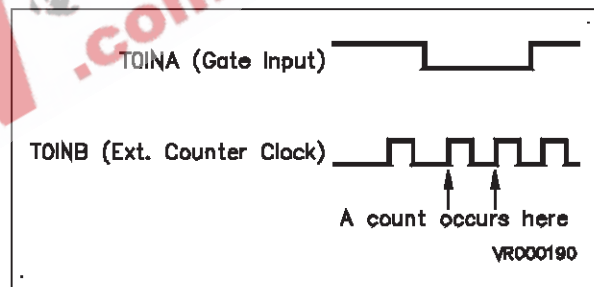

8.2.3.8 TxINA = Trigger - TxINB = Trigger

The signal applied to input pin A (or B) acts as trigger signal for REG0R (or REG1R), initiating the action for which the register has been programmed. The counter clock is internally generated and the up/down selection may be made only by software via the UDC (Software Up/Down) bit in the TCR register.

MULTIFUNCTION TIMER (Cont'd)

8.2.3.9 TxINA = Clock Up - TxINB = Clock Down

The edge received on input pin A (or B) performs a one step up (or down) count, so that the counter clock and the up/down control are external. Setting the UDC bit in the TCR register has no effect in this configuration, and input pin B has priority on input pin A.

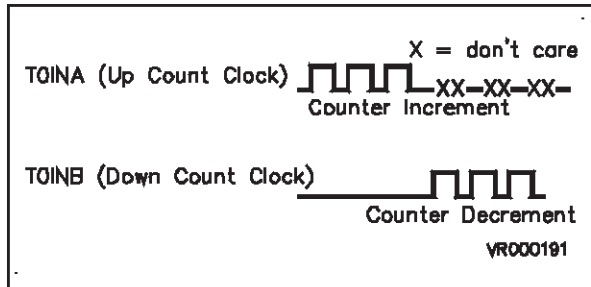

8.2.3.10 TxINA = Up/Down - TxINB = Ext Clock

An High (or Low) level applied to input pin A sets the counter in the up (or down) count mode, while the signal applied to input pin B is used as clock for the prescaler. Setting the UDC bit in the TCR register has no effect in this configuration.

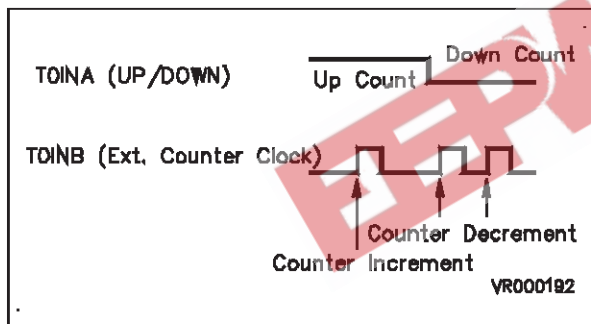

8.2.3.11 TxINA = Trigger Up - TxINB = Trigger Down

Up/down control is performed through both input pins A and B. A edge on input pin A sets the up count mode, while a edge on input pin B (which has priority on input pin A) sets the down count mode. The counter clock is internally generated, and setting the UDC bit in the TCR register has no effect in this configuration.

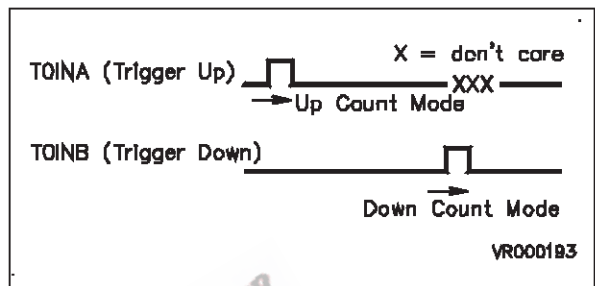

8.2.3.12 TxINA = Up/Down - TxINB = I/O

An High (or Low) level of the signal applied on input pin A sets the counter in the up (or down) count mode. The counter clock is internally generated. Setting the UDC bit in the TCR register has no effect in this configuration.

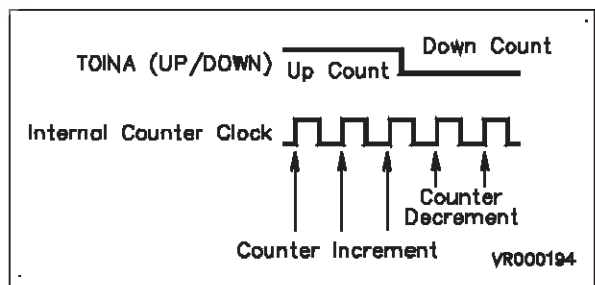

MULTIFUNCTION TIMER (Cont'd)

8.2.3.13 Autodiscrimination Mode

The phase between two pulses (respectively on input pin B and input pin A) generates a one step up (or down) count, so that the up/down control and the counter clock are both external. Thus, if the rising edge of TxINB arrives when TxINA is at a low level, the timer is incremented (no action if the rising edge of TxINB arrives when TxINA is at a high level). If the falling edge of TxINB arrives when TxINA is at a low level, the timer is decremented (no action if the falling edge of TxINB arrives when TxINA is at a high level).

Setting the UDC bit in the TCR register has no effect in this configuration.

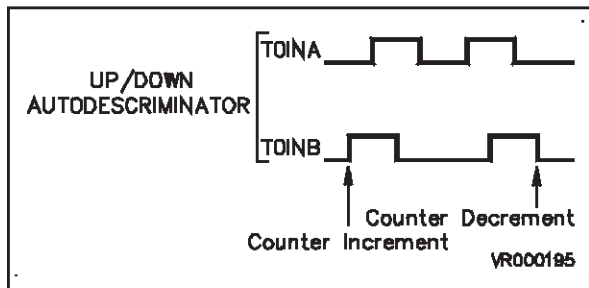

8.2.3.14 TxINA = Trigger - TxINB = Ext. Clock

The signal applied to input pin A acts as a trigger signal on REG0R, initiating the action for which the register was programmed (i.e. a reload or cap-

ture), while the signal applied to input pin B is used as the clock for the prescaler.

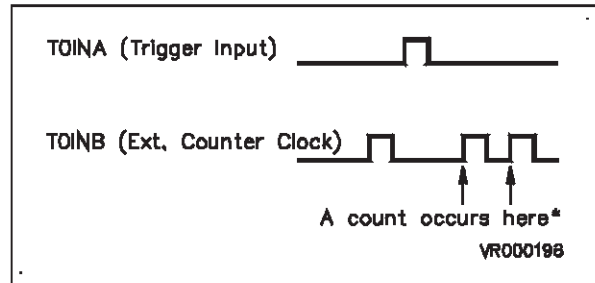

(*) The timer is in One shot mode and REG0R in reload mode

8.2.3.15 TxINA = Ext. Clock - TxINB = Trigger

The signal applied to input pin B acts as a trigger, performing a capture on REG1R, while the signal applied to input pin A is used as the clock for the prescaler.

8.2.3.16 TxINA = Trigger - TxINB = Gate

The signal applied to input pin A acts as a trigger signal on REG0R, initiating the action for which the register was programmed (i.e. a reload or capture), while the signal applied to input pin B acts as a gate signal for the internal clock (i.e. the counter runs only when the gate signal is at a low level).

MULTIFUNCTION TIMER (Cont'd)

8.2.4 Output Pin Assignment

Two external outputs are available when programmed as Alternate Function Outputs of the I/O pins.

Two registers Output A Control Register (OACR) and Output B Control Register (OBCR) define the driver for the outputs and the actions to be performed.

Each of the two output pins can be driven from any of the three possible sources:

- Compare Register 0 event logic
- Compare Register 1 event logic
- Overflow/Underflow event logic.

Each of these three sources can cause one of the following four actions on any of the two outputs:

- Nop
- Set
- Reset
- Toggle

Furthermore an On Chip Event signal can be driven by two of the three sources: the Over/Underflow event and Compare 0 event by programming the CEV bit of the OACR register and the OEV bit of OBCR register respectively. This signal can be used internally to synchronise another on-chip peripheral.

Output Waveforms

Depending on the programming of OACR and OBCR, the following example waveforms can be generated on TxOUTA and TxOUTB pins.

For a configuration where TxOUTA is driven by the Over/Underflow (OUF) and the Compare 0 event (CM0), and TxOUTB is driven by the Over/Underflow and Compare 1 event (CM1):

OACR is programmed with TxOUTA preset to "0", OUF sets TxOUTA, CM0 resets TxOUTA and CM1 does not affect the output. OBCR is programmed with TxOUTB preset to "0", OUF sets TxOUTB, CM1 resets TxOUTB while CM0 does not affect the output.

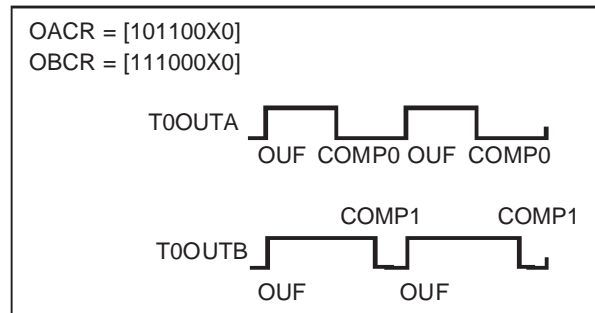

For a configuration where TxOUTA is driven by the Over/Underflow, by Compare 0 and by Compare 1; TxOUTB is driven by both Compare 0 and Compare 1. OACR is programmed with TxOUTA preset to "0". OUF toggles Output 0, as do CM0 and CM1. OBCR is programmed with TxOUTB preset to "1". OUF does not affect the output; CM0 resets TxOUTB and CM1 sets it.

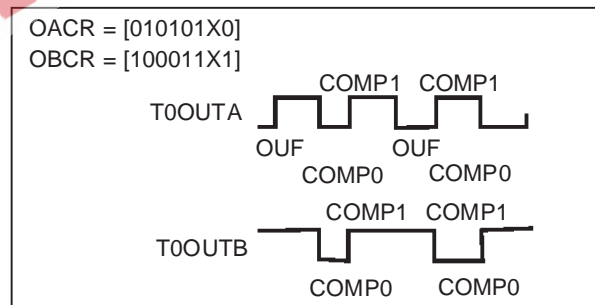

MULTIFUNCTION TIMER (Cont'd)

For a configuration where TxOUTA is driven by the Over/Underflow and by Compare 0, and TxOUTB is driven by the Over/Underflow and by Compare 1. OACR is programmed with TxOUTA preset to "0". OUF sets TxOUTA while CM0 resets it, and CM1 has no effect. OBCR is programmed with TxOUTB preset to "1". OUF toggles TxOUTB, CM1 sets it and CM0 has no effect.

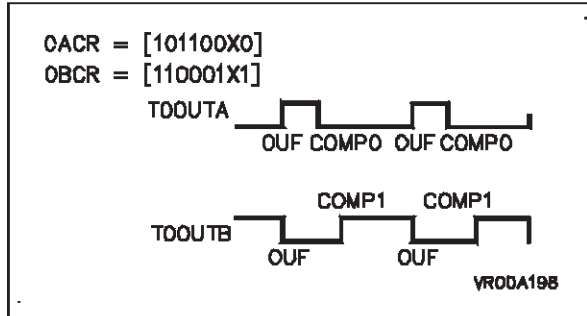

For a configuration where TxOUTA is driven by the Over/Underflow and by Compare 0, and TxOUTB is driven by Compare 0 and 1. OACR is programmed with TxOUTA preset to "0". OUF sets TxOUTA, CM0 resets it and CM1 has no effect. OBCR is programmed with TxOUTB preset to "0". OUF has no effect, CM0 sets TxOUTB and CM1 toggles it.

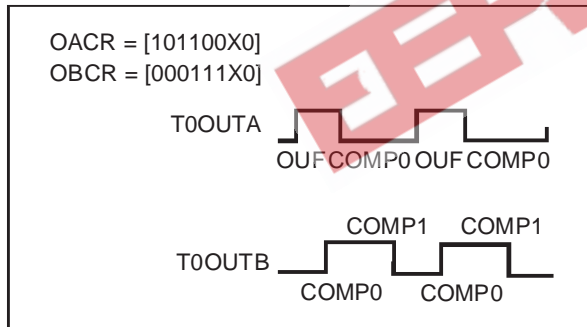

Output Waveform Samples In Biload Mode

TxOUTA is programmed to monitor the two time intervals, t1 and t2, of the Biload Mode, while TxOUTB is independent of the Over/Underflow and is driven by the different values of Compare 0 and Compare 1. OACR is programmed with TxOUTA preset to "0". OUF toggles the output and CM0 and CM1 do not affect TxOUTA. OBCR is programmed with TxOUTB preset to "0". OUF has no effect, while CM1 resets TxOUTB and CM0 sets it.

Depending on the CM1/CM0 values, three different sample waveforms have been drawn based on the above mentioned configuration of OBCR. In the last case, with a different programmed value of OBCR, only Compare 0 drives TxOUTB, toggling the output.

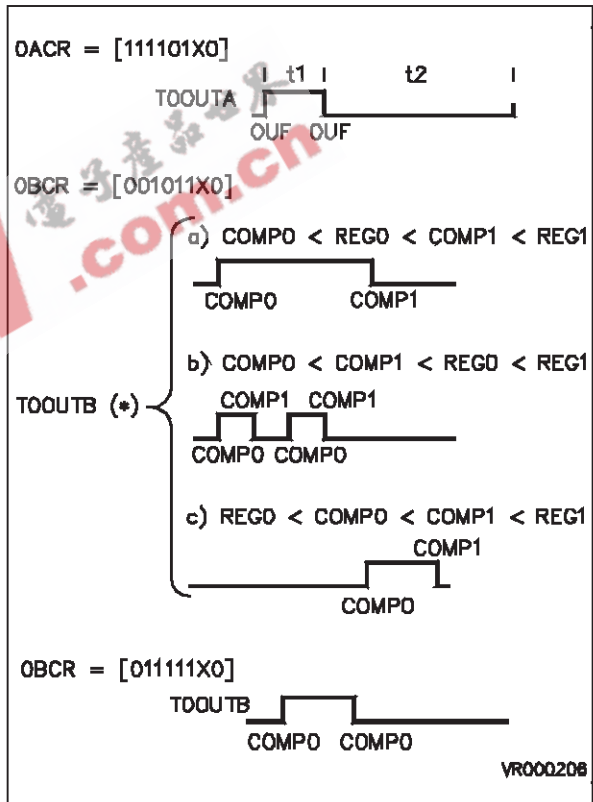

Note (*) Depending on the CMP1R/CMP0R values

MULTIFUNCTION TIMER (Cont'd)

8.2.5 Interrupt and DMA

8.2.5.1 Timer Interrupt

The timer has 5 different Interrupt sources, belonging to 3 independent groups, which are assigned to the following Interrupt vectors:

Table 22. Timer Interrupt Structure

Interrupt Source	Vector Address
COMP 0 COMP 1	xxxx x110
CAPT 0 CAPT 1	xxxx x100
Overflow/Underflow	xxxx x000

The three least significant bits of the vector pointer address represent the relative priority assigned to each group, where 000 represents the highest priority level. These relative priorities are fixed by hardware, according to the source which generates the interrupt request. The 5 most significant bits represent the general priority and are programmed by the user in the Interrupt Vector Register (T_IVR).

Each source can be masked by a dedicated bit in the Interrupt/DMA Mask Register (IDMR) of each timer, as well as by a global mask enable bit (IDMR.7) which masks all interrupts.

If an interrupt request (CM0 or CP0) is present before the corresponding pending bit is reset, an overrun condition occurs. This condition is flagged in two dedicated overrun bits, relating to the Comp0 and Capt0 sources, in the Timer Flag Register (T_FLAGR).

8.2.5.2 Timer DMA

Two Independent DMA channels, associated with Comp0 and Capt0 respectively, allow DMA transfers from Register File or Memory to the Comp0 Register, and from the Capt0 Register to Register File or Memory). If DMA is enabled, the Capt0 and Comp0 interrupts are generated by the corresponding DMA End of Block event. Their priority is set by hardware as follows:

- Compare 0 Destination — Lower Priority
- Capture 0 Source — Higher Priority

The two DMA request sources are independently maskable by the CP0D and CM0D DMA Mask bits in the IDMR register.

The two DMA End of Block interrupts are independently enabled by the CP0I and CM0I Interrupt mask bits in the IDMR register.

8.2.5.3 DMA Pointers

The 6 programmable most significant bits of the DMA Counter Pointer Register (DCPR) and of the DMA Address Pointer Register (DAPR) are common to both channels (Comp0 and Capt0). The Comp0 and Capt0 Address Pointers are mapped as a pair in the Register File, as are the Comp0 and Capt0 DMA Counter pair.

In order to specify either the Capt0 or the Comp0 pointers, according to the channel being serviced, the Timer resets address bit 1 for CAPT0 and sets it for COMP0, when the D0 bit in the DCPR register is equal to zero (Word address in Register File). In this case (transfers between peripheral registers and memory), the pointers are split into two groups of adjacent Address and Counter pairs respectively.

For peripheral register to register transfers (selected by programming "1" into bit 0 of the DCPR register), only one pair of pointers is required, and the pointers are mapped into one group of adjacent positions.

The DMA Address Pointer Register (DAPR) is not used in this case, but must be considered reserved.

Figure 67. Pointer Mapping for Transfers between Registers and Memory

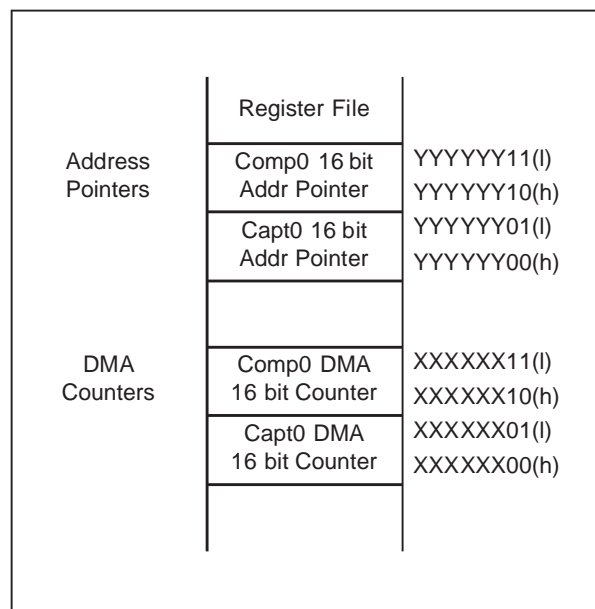

MULTIFUNCTION TIMER (Cont'd)

Figure 68. Pointer Mapping for Register to Register Transfers

Register File		
8 bit Counter	XXXXXX11	Compare 0
8 bit Addr Pointer	XXXXXX10	
8 bit Counter	XXXXXX01	Capture 0
8 bit Addr Pointer	XXXXXX00	

8.2.5.4 DMA Transaction Priorities

Each Timer DMA transaction is a 16-bit operation, therefore two bytes must be transferred sequentially, by means of two DMA transfers. In order to speed up each word transfer, the second byte transfer is executed by automatically forcing the peripheral priority to the highest level (000), regardless of the previously set level. It is then restored to its original value after executing the transfer. Thus, once a request is being serviced, its hardware priority is kept at the highest level regardless of the other Timer internal sources, i.e. once a Comp0 request is being serviced, it maintains a higher priority, even if a Capt0 request occurs between the two byte transfers.

8.2.5.5 DMA Swap Mode

After a complete data table transfer, the transaction counter is reset and an End Of Block (EOB) condition occurs, the block transfer is completed.

The End Of Block Interrupt routine must at this point reload both address and counter pointers of the channel referred to by the End Of Block interrupt source, if the application requires a continuous high speed data flow. This procedure causes speed limitations because of the time required for the reload routine.

The SWAP feature overcomes this drawback, allowing high speed continuous transfers. Bit 2 of the DMA Counter Pointer Register (DCPR) and of the DMA Address Pointer Register (DAPR), toggles after every End Of Block condition, alternately providing odd and even address (D2-D7) for the pair of pointers, thus pointing to an updated pair, after a block has been completely transferred. This allows the User to update or read the first block and to update the pointer values while the second is being transferred. These two toggle bits are software writable and readable, mapped in DCPR bit 2 for the CM0 channel, and in DAPR bit 2 for the CP0 channel (though a DMA event on a channel, in Swap mode, modifies a field in DAPR and DCPR common to both channels, the DAPR/DCPR content used in the transfer is always the bit related to the correct channel).

SWAP mode can be enabled by the SWEN bit in the IDCR Register.

WARNING: Enabling SWAP mode affects both channels (CM0 and CP0).

MULTIFUNCTION TIMER (Cont'd)

8.2.5.6 DMA End Of Block Interrupt Routine

An interrupt request is generated after each block transfer (EOB) and its priority is the same as that assigned in the usual interrupt request, for the two channels. As a consequence, they will be serviced only when no DMA request occurs, and will be subject to a possible OUF Interrupt request, which has higher priority.

The following is a typical EOB procedure (with swap mode enabled):

- Test Toggle bit and Jump.
- Reload Pointers (odd or even depending on toggle bit status).
- Reset EOB bit: this bit must be reset only after the old pair of pointers has been restored, so that, if a new EOB condition occurs, the next pair of pointers is ready for swapping.
- Verify the software protection condition (see Section 0.1.5.7).
- Read the corresponding Overrun bit: this confirms that no DMA request has been lost in the meantime.
- Reset the corresponding pending bit.
- Reenable DMA with the corresponding DMA mask bit (**must always be done after resetting the pending bit**)

– Return.

WARNING: The EOB bits are read/write **only** for test purposes. Writing a logical “1” by software (when the SWEN bit is set) will cause a spurious interrupt request. These bits are normally only reset by software.

8.2.5.7 DMA Software Protection

A second EOB condition may occur before the first EOB routine is completed, this would cause a not yet updated pointer pair to be addressed, with consequent overwriting of memory. To prevent these errors, a protection mechanism is provided, such that the attempted setting of the EOB bit before it has been reset by software will cause the DMA mask on that channel to be reset (DMA disabled), thus blocking any further DMA operation. As shown above, this mask bit should always be checked in each EOB routine, to ensure that all DMA transfers are properly served.

8.2.6 Register Description

Note: In the register description on the following pages, register and page numbers are given using the example of Timer 0. On devices with more than one timer, refer to the device register map for the addresses and page numbers.

MULTIFUNCTION TIMER (Cont'd)

CAPTURE LOAD 0 HIGH REGISTER (REG0HR)

R240 - Read/Write
 Register Page: 10
 Reset value: undefined

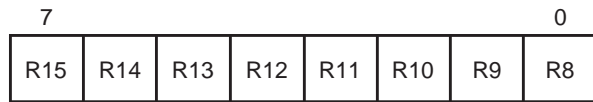

This register is used to capture values from the Up/Down counter or load preset values (MSB).

CAPTURE LOAD 0 LOW REGISTER (REG0LR)

R241 - Read/Write
 Register Page: 10
 Reset value: undefined

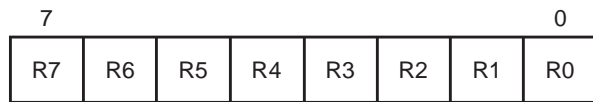

This register is used to capture values from the Up/Down counter or load preset values (LSB).

CAPTURE LOAD 1 HIGH REGISTER (REG1HR)

R242 - Read/Write
 Register Page: 10
 Reset value: undefined

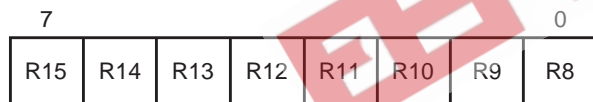

This register is used to capture values from the Up/Down counter or load preset values (MSB).

CAPTURE LOAD 1 LOW REGISTER (REG1LR)

R243 - Read/Write
 Register Page: 10
 Reset value: undefined

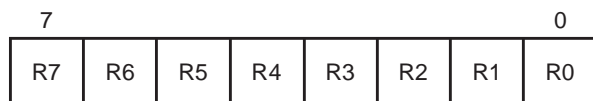

This register is used to capture values from the Up/Down counter or load preset values (LSB).

COMPARE 0 HIGH REGISTER (CMP0HR)

R244 - Read/Write
 Register Page: 10
 Reset value: 0000 0000 (00h)

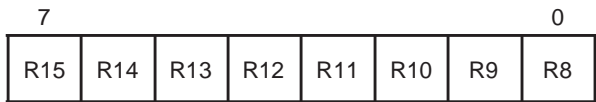

This register is used to store the MSB of the 16-bit value to be compared to the Up/Down counter content.

COMPARE 0 LOW REGISTER (CMP0LR)

R245 - Read/Write
 Register Page: 10
 Reset value: 0000 0000 (00h)



This register is used to store the LSB of the 16-bit value to be compared to the Up/Down counter content.

COMPARE 1 HIGH REGISTER (CMP1HR)

R246 - Read/Write
 Register Page: 10
 Reset value: 0000 0000 (00h)

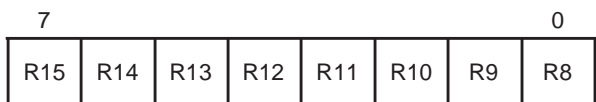

This register is used to store the MSB of the 16-bit value to be compared to the Up/Down counter content.

COMPARE 1 LOW REGISTER (CMP1LR)

R247 - Read/Write
 Register Page: 10
 Reset value: 0000 0000 (00h)

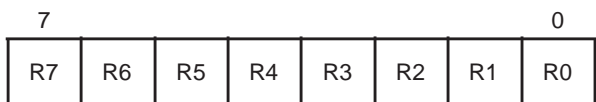

This register is used to store the LSB of the 16-bit value to be compared to the Up/Down counter content.

ST92163 - MULTIFUNCTION TIMER (MFT)

MULTIFUNCTION TIMER (Cont'd)

TIMER CONTROL REGISTER (TCR)

R248 - Read/Write

Register Page: 10

Reset value: 0000 0000 (00h)

7							0
CEN	CCP 0	CCMP 0	CCL	UDC	UDC S	OF0	CS

Bit 7 = **CEN**: Counter enable.

This bit is ANDed with the Global Counter Enable bit (GCEN) in the CICR register (R230). The GCEN bit is set after the Reset cycle.

0: Stop the counter and prescaler

1: Start the counter and prescaler (without reload).

Note: Even if CEN=0, capture and loading will take place on a trigger event.

Bit 6 = **CCP0**: Clear on capture.

0: No effect

1: Clear the counter and reload the prescaler on a REG0R or REG1R capture event

Bit 5 = **CCMP0**: Clear on Compare.

0: No effect

1: Clear the counter and reload the prescaler on a CMP0R compare event

Bit 4 = **CCL**: Counter clear.

This bit is reset by hardware after being set by software (this bit always returns "0" when read).

0: No effect

1: Clear the counter without generating an interrupt request

Bit 3 = **UDC**: Up/Down software selection.

If the direction of the counter is not fixed by hardware (TxINA and/or TxINB pins, see par. 10.3) it can be controlled by software using the UDC bit.

0: Down counting

1: Up counting

Bit 2 = **UDCS**: Up/Down count status.

This bit is read only and indicates the direction of the counter.

0: Down counting

1: Up counting

Bit 1 = **OF0**: OVF/UNF state.

This bit is read only.

0: No overflow or underflow occurred

1: Overflow or underflow occurred during a Capture on Register 0

Bit 0 = **CS**: Counter Status.

This bit is read only and indicates the status of the counter.

0: Counter halted

1: Counter running

MULTIFUNCTION TIMER (Cont'd)

TIMER MODE REGISTER (TMR)

R249 - Read/Write

Register Page: 10

Reset value: 0000 0000 (00h)

7							0
OE1	OE0	BM	RM1	RM0	ECK	REN	CO

Bit 7 = **OE1**: *Output 1 enable.*

0: Disable the Output 1 (TxOUTB pin) and force it high.

1: Enable the Output 1 (TxOUTB pin)

The relevant I/O bit must also be set to Alternate Function

Bit 6 = **OE0**: *Output 0 enable.*

0: Disable the Output 0 (TxOUTA pin) and force it high

1: Enable the Output 0 (TxOUTA pin).

The relevant I/O bit must also be set to Alternate Function

Bit 5 = **BM**: *Bivalue mode.*

This bit works together with the RM1 and RM0 bits to select the timer operating mode (see Table 4).

0: Disable bivalue mode

1: Enable bivalue mode

Bit 4 = **RM1**: *REG1R mode.*

This bit works together with the BM and RM0 bits to select the timer operating mode. Refer to Table 4.

Note: This bit has no effect when the Bivalue Mode is enabled (BM=1).

Bit 3 = **RM0**: *REG0R mode.*

This bit works together with the BM and RM1 bits to select the timer operating mode. Refer to Table 4.

Table 23. Timer Operating Modes

TMR Bits			Timer Operating Modes
BM	RM1	RM0	
1	x	0	Biload mode
1	x	1	Bicapture mode
0	0	0	Load from REG0R and Monitor on REG1R
0	1	0	Load from REG0R and Capture on REG1R
0	0	1	Capture on REG0R and Monitor on REG1R
0	1	1	Capture on REG0R and REG1R

Bit 2 = **ECK**: *Timer clock control.*

0: The prescaler clock source is selected depending on the IN0 - IN3 bits in the T_ICR register

1: Enter Parallel mode (for Timer 1 and Timer 3 only; no effect for Timer 0 and 2). See Section 0.1.2.12.

Bit 1 = **REN**: *Retrigger mode.*

0: Enable retriggerable mode

1: Disable retriggerable mode

Bit 0 = **CO**: *Continuous/One shot mode.*

0: Continuous mode (with autoreload on End of Count condition)

1: One shot mode

ST92163 - MULTIFUNCTION TIMER (MFT)

MULTIFUNCTION TIMER (Cont'd)

EXTERNAL INPUT CONTROL REGISTER (T_ICR)

R250 - Read/Write

Register Page: 10

Reset value: 0000 0000 (00h)

7							0
IN3	IN2	IN1	IN0	A0	A1	B0	B1

Bit 7:4 = **IN[3:0]**: *Input pin function.*

These bits are set and cleared by software.

IN[3:0] bits	TxINA Pin Function	TxINB Input Pin Function
0000	not used	not used
0001	not used	Trigger
0010	Gate	not used
0011	Gate	Trigger
0100	not used	Ext. Clock
0101	Trigger	not used
0110	Gate	Ext. Clock
0111	Trigger	Trigger
1000	Clock Up	Clock Down
1001	Up/Down	Ext. Clock
1010	Trigger Up	Trigger Down
1011	Up/Down	not used
1100	Autodiscr.	Autodiscr.
1101	Trigger	Ext. Clock
1110	Ext. Clock	Trigger
1111	Trigger	Gate

Bit 3:2 = **A[0:1]**: *TxINA Pin event.*

These bits are set and cleared by software.

A0	A1	TxINA Pin Event
0	0	No operation
0	1	Falling edge sensitive
1	0	Rising edge sensitive
1	1	Rising and falling edges

Bit 1:0 = **B[0:1]**: *TxINB Pin event.*

These bits are set and cleared by software.

B0	B1	TxINB Pin Event
0	0	No operation
0	1	Falling edge sensitive
1	0	Rising edge sensitive
1	1	Rising and falling edges

PRESCALER REGISTER (PRSR)

R251 - Read/Write

Register Page: 10

Reset value: 0000 0000 (00h)

7							0
P7	P6	P5	P4	P3	P2	P1	P0

This register holds the preset value for the 8-bit prescaler. The PRSR content may be modified at any time, but it will be loaded into the prescaler at the following prescaler underflow, or as a consequence of a counter reload (either by software or upon external request).

Following a RESET condition, the prescaler is automatically loaded with 00h, so that the prescaler divides by 1 and the maximum counter clock is generated (OSCIN frequency divided by 6 when MODER.5 = DIV2 bit is set).

The binary value programmed in the PRSR register is equal to the divider value minus one. For example, loading PRSR with 24 causes the prescaler to divide by 25.

MULTIFUNCTION TIMER (Cont'd)

OUTPUT A CONTROL REGISTER (OACR)

R252 - Read/Write
 Register Page: 10
 Reset value: 0000 0000

7							0
C0E0	C0E1	C1E0	C1E1	OUE0	OUE1	CEV	OP

Note: Whenever more than one event occurs simultaneously, the action taken will be the result of ANDing the event bits xxE1-xxE0.

Bit 7:6 = **C0E[0:1]**: *COMP0 event bits*.
 These bits are set and cleared by software.

C0E0	C0E1	Action on TxOUTA pin on a successful compare of the CMP0R register
0	0	Set
0	1	Toggle
1	0	Reset
1	1	NOP

Bit 5:4 = **C1E[0:1]**: *COMP1 event bits*.
 These bits are set and cleared by software.

C1E0	C1E1	Action on TxOUTA pin on a successful compare of the CMP1R register
0	0	Set
0	1	Toggle
1	0	Reset
1	1	NOP

Bit 3:2 = **OUE[0:1]**: *OVF/UNF event bits*.
 These bits are set and cleared by software.

OUE0	OUE1	Action on TxOUTA pin on an Overflow or Underflow on the U/D counter
0	0	Set
0	1	Toggle
1	0	Reset
1	1	NOP

Note: Whenever more than one event occurs simultaneously, the action taken will be the result of ANDing the event xxE1-xxE0 bits.

Bit 1 = **CEV**: *On-Chip event on CMP0R*.
 This bit is set and cleared by software.

0: No action
 1: A successful compare on CMP0R activates the on-chip event signal (a single pulse is generated)

Bit 0 = **OP**: *TxOUTA preset value*.
 This bit is set and cleared by software and by hardware. The value of this bit is the preset value of the TxOUTA pin. Reading this bit returns the current state of the TxOUTA pin (useful when it is selected in toggle mode).

ST92163 - MULTIFUNCTION TIMER (MFT)

MULTIFUNCTION TIMER (Cont'd)

OUTPUT B CONTROL REGISTER (OBCR)

R253 - Read/Write

Register Page: 10

Reset value: 0000 0000 (00h)

7							0
C0E0	C0E1	C1E0	C1E1	OUE0	OUE1	OEV	OP

Note: Whenever more than one event occurs simultaneously, the action taken will be the result of ANDing the event bits xxE1-xxE0.

Bit 7:6 = **C0E[0:1]**: *COMP0* event bits.
These bits are set and cleared by software.

C0E0	C0E1	Action on TxOUTB pin on a successful compare of the CMP0R register
0	0	Set
0	1	Toggle
1	0	Reset
1	1	NOP

Bit 5:4 = **C1E[0:1]**: *COMP1* event bits.
These bits are set and cleared by software.

C1E0	C1E1	Action on TxOUTB pin on a successful compare of the CMP1R register
0	0	Set
0	1	Toggle
1	0	Reset
1	1	NOP

Bit 3:2 = **OUE[0:1]**: *OVF/UNF* event bits.
These bits are set and cleared by software.

OUE0	OUE1	Action on TxOUTB pin on an Overflow or Underflow on the U/D counter
0	0	Set
0	1	Toggle
1	0	Reset
1	1	NOP

Bit 1 = **OEV**: *On-Chip event on OVF/UNF*.
This bit is set and cleared by software.

0: No action

1: An underflow/overflow activates the on-chip event signal (a single pulse is generated)

Bit 0 = **OP**: *TxOUTB* preset value.

This bit is set and cleared by software and by hardware. The value of this bit is the preset value of the TxOUTB pin. Reading this bit returns the current state of the TxOUTB pin (useful when it is selected in toggle mode).

MULTIFUNCTION TIMER (Cont'd)

FLAG REGISTER (T_FLAGR)

R254 - Read/Write

Register Page: 10

Reset value: 0000 0000 (00h)

7	0						
CP0	CP1	CM0	CM1	OUF	OCP 0	OCM 0	A0

Bit 7 = CP0: Capture 0 flag.

This bit is set by hardware after a capture on REG0R register. An interrupt is generated depending on the value of the GTIEN, CP0I bits in the IDMR register and the A0 bit in the T_FLAGR register. The CP0 bit must be cleared by software. Setting by software acts as a software load/capture to/from the REG0R register.

0: No Capture 0 event

1: Capture 0 event occurred

Bit 6 = CP1: Capture 1 flag.

This bit is set by hardware after a capture on REG1R register. An interrupt is generated depending on the value of the GTIEN, CP0I bits in the IDMR register and the A0 bit in the T_FLAGR register. The CP1 bit must be cleared by software. Setting by software acts as a capture event on the REG1R register, except when in Bicapture mode.

0: No Capture 1 event

1: Capture 1 event occurred

Bit 5 = CM0: Compare 0 flag.

This bit is set by hardware after a successful compare on the CMP0R register. An interrupt is generated if the GTIEN and CM0I bits in the IDMR register are set. The CM0 bit is cleared by software.

0: No Compare 0 event

1: Compare 0 event occurred

Bit 4 = CM1: Compare 1 flag.

This bit is set after a successful compare on CMP1R register. An interrupt is generated if the

GTIEN and CM1I bits in the IDMR register are set. The CM1 bit is cleared by software.

0: No Compare 1 event

1: Compare 1 event occurred

Bit 3 = OUF: Overflow/Underflow.

This bit is set by hardware after a counter Over/Underflow condition. An interrupt is generated if GTIEN and OUI=1 in the IDMR register. The OUF bit is cleared by software.

0: No counter overflow/underflow

1: Counter overflow/underflow

Bit 2 = OCP0: Overrun on Capture 0.

This bit is set by hardware when more than one INT/DMA requests occur before the CP0 flag is cleared by software or whenever a capture is simulated by setting the CP0 flag by software. The OCP0 flag is cleared by software.

0: No capture 0 overrun

1: Capture 0 overrun

Bit 1 = OCM0: Overrun on compare 0.

This bit is set by hardware when more than one INT/DMA requests occur before the CM0 flag is cleared by software. The OCM0 flag is cleared by software.

0: No compare 0 overrun

1: Compare 0 overrun

Bit 0 = A0: Capture interrupt function.

This bit is set and cleared by software.

0: Configure the capture interrupt as an OR function of REG0R/REG1R captures

1: Configure the capture interrupt as an AND function of REG0R/REG1R captures

MULTIFUNCTION TIMER (Cont'd)

INTERRUPT/DMA MASK REGISTER (IDMR)

R255 - Read/Write

Register Page: 10

Reset value: 0000 0000 (00h)

7							0
GT-IEN	CP0D	CP0I	CP1I	CM0D	CM0I	CM1I	OUI

Bit 7 = **GTIEN**: *Global timer interrupt enable.*
 This bit is set and cleared by software.
 0: Disable all Timer interrupts
 1: Enable all timer Timer Interrupts from enabled sources

Bit 6 = **CP0D**: *Capture 0 DMA mask.*
 This bit is set by software to enable a Capt0 DMA transfer and cleared by hardware at the end of the block transfer.
 0: Disable capture on REG0R DMA
 1: Enable capture on REG0R DMA

Bit 5 = **CP0I**: *Capture 0 interrupt mask.*
 0: Disable capture on REG0R interrupt
 1: Enable capture on REG0R interrupt (or Capt0 DMA End of Block interrupt if CP0D=1)

Bit 4 = **CP1I**: *Capture 1 interrupt mask.*
 This bit is set and cleared by software.
 0: Disable capture on REG1R interrupt
 1: Enable capture on REG1R interrupt

Bit 3 = **CM0D**: *Compare 0 DMA mask.*
 This bit is set by software to enable a Comp0 DMA transfer and cleared by hardware at the end of the block transfer.
 0: Disable compare on CMP0R DMA
 1: Enable compare on CMP0R DMA

Bit 2 = **CM0I**: *Compare 0 Interrupt mask.*
 This bit is set and cleared by software.
 0: Disable compare on CMP0R interrupt
 1: Enable compare on CMP0R interrupt (or Comp0 DMA End of Block interrupt if CM0D=1)

Bit 1 = **CM1I**: *Compare 1 Interrupt mask.*
 This bit is set and cleared by software.
 0: Disable compare on CMP1R interrupt
 1: Enable compare on CMP1R interrupt

Bit 0 = **OUI**: *Overflow/Underflow interrupt mask.*
 This bit is set and cleared by software.
 0: Disable Overflow/Underflow interrupt
 1: Enable Overflow/Underflow interrupt

DMA COUNTER POINTER REGISTER (DCPR)

R240 - Read/Write

Register Page: 9

Reset value: undefined

7							0
DCP7	DCP6	DCP5	DCP4	DCP3	DCP2	DMA SRCE	REG/MEM

Bit 7:2 = **DCP[7:2]**: *MSBs of DMA counter register address.*

These are the most significant bits of the DMA counter register address programmable by software. The DCP2 bit may also be toggled by hardware if the Timer DMA section for the Compare 0 channel is configured in Swap mode.

Bit 1 = **DMA-SRCE**: *DMA source selection.*
 This bit is set and cleared by hardware.
 0: DMA source is a Capture on REG0R register
 1: DMA destination is a Compare on CMP0R register

Bit 0 = **REG/MEM**: *DMA area selection.*
 This bit is set and cleared by software. It selects the source and destination of the DMA area
 0: DMA from/to memory
 1: DMA from/to Register File

MULTIFUNCTION TIMER (Cont'd)

DMA ADDRESS POINTER REGISTER (DAPR)

R241 - Read/Write
 Register Page: 9
 Reset value: undefined

7	6	5	4	3	2	1	0
DAP 7	DAP 6	DAP5	DAP4	DAP3	DAP2	DMA SRCE	PRG /DAT

Bit 7:2 = **DAP[7:2]**: MSB of DMA address register location.

These are the most significant bits of the DMA address register location programmable by software. The DAP2 bit may also be toggled by hardware if the Timer DMA section for the Compare 0 channel is configured in Swap mode.

Note: During a DMA transfer with the Register File, the DAPR is not used; however, in Swap mode, DAPR(2) is used to point to the correct table.

Bit 1 = **DMA-SRCE**: DMA source selection.
 This bit is fixed by hardware.

- 0: DMA source is a Capture on REG0R register
- 1: DMA destination is a Compare on the CMP0R register

Bit 0 = **PRG/DAT**: DMA memory selection.
 This bit is set and cleared by software. It is only meaningful if DCPR.REG/MEM=0.

- 0: The ISR register is used to extend the address of data transferred by DMA (see MMU chapter).
- 1: The DMASR register is used to extend the address of data transferred by DMA (see MMU chapter).

REG/MEM	PRG/DAT	DMA Source/Destination
0	0	ISR register used to address memory
0	1	DMASR register used to address memory
1	0	Register file
1	1	Register file

INTERRUPT VECTOR REGISTER (T_IVR)

R242 - Read/Write
 Register Page: 9
 Reset value: **xxxx xxx0**

7	6	5	4	3	2	1	0
V4	V3	V2	V1	V0	W1	W0	0

This register is used as a vector, pointing to the 16-bit interrupt vectors in memory which contain the starting addresses of the three interrupt sub-routines managed by each timer.

Only one Interrupt Vector Register is available for each timer, and it is able to manage three interrupt groups, because the 3 least significant bits are fixed by hardware depending on the group which generated the interrupt request.

In order to determine which request generated the interrupt within a group, the T_FLAGR register can be used to check the relevant interrupt source.

Bit 7:3 = **V[4:0]**: MSB of the vector address.
 These bits are user programmable and contain the five most significant bits of the Timer interrupt vector addresses in memory. In any case, an 8-bit address can be used to indicate the Timer interrupt vector locations, because they are within the first 256 memory locations (see Interrupt and DMA chapters).

Bit 2:1 = **W[1:0]**: Vector address bits.
 These bits are equivalent to bit 1 and bit 2 of the Timer interrupt vector addresses in memory. They are fixed by hardware, depending on the group of sources which generated the interrupt request as follows:.

W1	W0	Interrupt Source
0	0	Overflow/Underflow even interrupt
0	1	Not available
1	0	Capture event interrupt
1	1	Compare event interrupt

Bit 0 = This bit is forced by hardware to 0.

MULTIFUNCTION TIMER (Cont'd)

INTERRUPT/DMA CONTROL REGISTER (IDCR)

R243 - Read/Write
 Register Page: 9
 Reset value: 1100 0111 (C7h)

7							0
CPE	CME	DCTS	DCT D	SWE N	PL2	PL1	PL0

Bit 7 = **CPE**: *Capture 0 EOB*.
 This bit is set by hardware when the End Of Block condition is reached during a Capture 0 DMA operation with the Swap mode enabled. When Swap mode is disabled (SWEN bit = "0"), the CPE bit is forced to 1 by hardware.
 0: No end of block condition
 1: Capture 0 End of block

Bit 6 = **CME**: *Compare 0 EOB*.
 This bit is set by hardware when the End Of Block condition is reached during a Compare 0 DMA operation with the Swap mode enabled. When the Swap mode is disabled (SWEN bit = "0"), the CME bit is forced to 1 by hardware.
 0: No end of block condition
 1: Compare 0 End of block

Bit 5 = **DCTS**: *DMA capture transfer source*.
 This bit is set and cleared by software. It selects the source of the DMA operation related to the channel associated with the Capture 0.
Note: The I/O port source is available only on specific devices.
 0: REG0R register
 1: I/O port.

Bit 4 = **DCTD**: *DMA compare transfer destination*.
 This bit is set and cleared by software. It selects the destination of the DMA operation related to the channel associated with Compare 0.
Note: The I/O port destination is available only on specific devices.
 0: CMP0R register
 1: I/O port

Bit 3 = **SWEN**: *Swap function enable*.
 This bit is set and cleared by software.
 0: Disable Swap mode
 1: Enable Swap mode for both DMA channels.

Bit 2:0 = **PL[2:0]**: *Interrupt/DMA priority level*.
 With these three bits it is possible to select the Interrupt and DMA priority level of each timer, as one of eight levels (see Interrupt/DMA chapter).

I/O CONNECTION REGISTER (IOCR)

R248 - Read/Write
 Register Page: 9
 Reset value: 1111 1100 (FCh)

7							0
						SC1	SC0

Bit 7:2 = not used.
 Bit 1 = **SC1**: *Select connection odd*.
 This bit is set and cleared by software. It selects if the TxOUTA and TxINA pins for Timer 1 and Timer 3 are connected on-chip or not.
 0: T1OUTA / T1INA and T3OUTA/ T3INA unconnected
 1: T1OUTA connected internally to T1INA and T3OUTA connected internally to T3INA

Bit 0 = **SC0**: *Select connection even*.
 This bit is set and cleared by software. It selects if the TxOUTA and TxINA pins for Timer 0 and Timer 2 are connected on-chip or not.
 0: T0OUTA / T0INA and T2OUTA/ T2INA unconnected
 1: T0OUTA connected internally to T0INA and T2OUTA connected internally to T2INA

Note: Timer 1 and 2 are available only on some devices. Refer to the device block diagram and register map.

8.3 USB PERIPHERAL (USB)

8.3.1 Introduction

The USB Peripheral provides a full-speed function interface between the USB bus and the ST9 microcontroller.

8.3.2 Main Features

- USB Specification Version 1.1 Compliant
- Supports 8 device addresses
- 16 software configurable endpoints supporting:
 - All USB transfer types (control, interrupt, bulk , and isochronous)
 - Burst-DMA transfers to up to 1K bytes RAM buffers
- USB Suspend/Resume operations
- On-Chip 3.3V Regulator
- On-Chip USB Transceiver
- Special functions on alternate output pins:
 - USB upstream port Output Enable signal (USBOE)
 - Start-Of-Frame pulse (SOFP)
- Two bit-mirror registers

8.3.3 Functional Description

The USB interface is composed of the following blocks (see Figure 69)

- SIE (Serial Interface Engine): implementing USB protocol layer (for a detailed description of USB protocol refer to chapter 7, 8 of the “Universal Serial Bus Specification”). The functions of this block include: synchronisation

pattern recognition, bit-stuffing, CRC generation and checking, PID verification/generation and handshake evaluation. It must interface with USB bus on one side and with the ST9 core on the other side.

- ST9 interface: this block is connected between the SIE and the ST9 microcontroller. Its purpose is to handle specific endpoint registers and provide interrupt and DMA servicing to the SIE. The unit transfers data from or to the memory, and uses the Register File to save/load pointer and counter values without CPU intervention, taking control of the ST9 buses (Burst-DMA interface). The ST9 Interface unit uses interrupts to require attention from the microcontroller at the end of data transmission/reception, and to flag error conditions.
- Port Interface: this block contains the logic related to the USB physical port. The port interface also handles the resume detection.
- Frame Timer: its function is to monitor the Start-of-Frame (SOF) timing points. It detects a global suspend (from the host) when no USB traffic has been seen for 3 ms. It also generates the SOFP output for any external device requiring Start-of-Frame synchronization.
- Port transceiver: containing differential and single-ended receivers and slew rate controlled output buffers.

Figure 69. Block Diagram

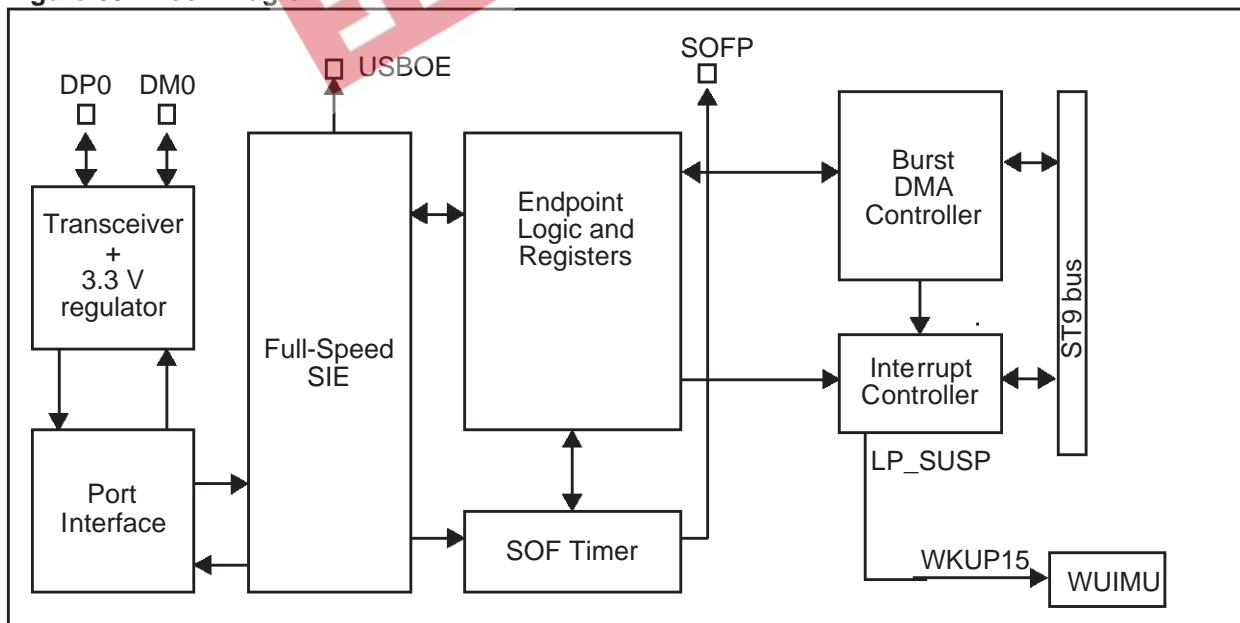

USB INTERFACE (Cont'd)

8.3.3.1 DMA transfer

DMA descriptors for each endpoint, located in the ST9 register file, indicate where the related memory buffer is located in RAM, how large the allocated buffer is and how many bytes must be transmitted. When a data transfer takes place, the USB-FS buffering data loaded in an internal 8 byte long FIFO buffer, and performing Burst-DMA transfers as appropriate. Then, if needed, the proper handshake answer is generated or expected, according to the direction of the transfer. At the end of the transaction, an interrupt is generated: using status registers and different interrupt vectors, the micro-controller can determine which endpoint was served, which type of transaction took place, if errors occurred (bit stuffing, format, CRC, protocol, missing ACK, over/underrun, etc...).

8.3.3.2 Structure and usage of DMA buffers

Each endpoint has two DMA buffers (one for transmission and the other for reception) whose size may be up to 1023 bytes each. They can be placed anywhere in memory (internally or externally).

For each endpoint, eight Register File locations are used:

ADDRn_TH and **ADDRn_TL**: These registers point to the starting address of the memory buffer containing the data to be transmitted by endpoint *n* at the next IN token addressed to it.

COUNTn_TL and **COUNTn_TH**: These registers contain the number of bytes to be transmitted by endpoint *n* at the next IN token addressed to it.

ADDRn_RL and **ADDRn_RH**: These registers point to the starting address of the memory buffer which will contain the data received by endpoint *n* at the next OUT/SETUP token addressed to it.

COUNTn_RL and **COUNTn_RH**: These registers contain the allocated buffer size for endpoint *n* reception, setting the maximum number of bytes the related endpoint can receive with the next OUT/SETUP transaction.

Other register locations related to unsupported transfer directions or unused endpoints, are available to the user. Isochronous endpoints have a special way of handling DMA buffers.

The relationship between register file locations and memory buffer areas is depicted in Figure 70.

Each DMA buffer is used starting from the bottom, either during reception or transmission.

The USB interface never changes the contents of memory locations adjacent to the DMA memory buffers; even if a packet bigger than the allocated buffer length is received (buffer overrun condition) the data will be copied in memory only up to the last available location.

Figure 70. DMA buffers and related register file locations

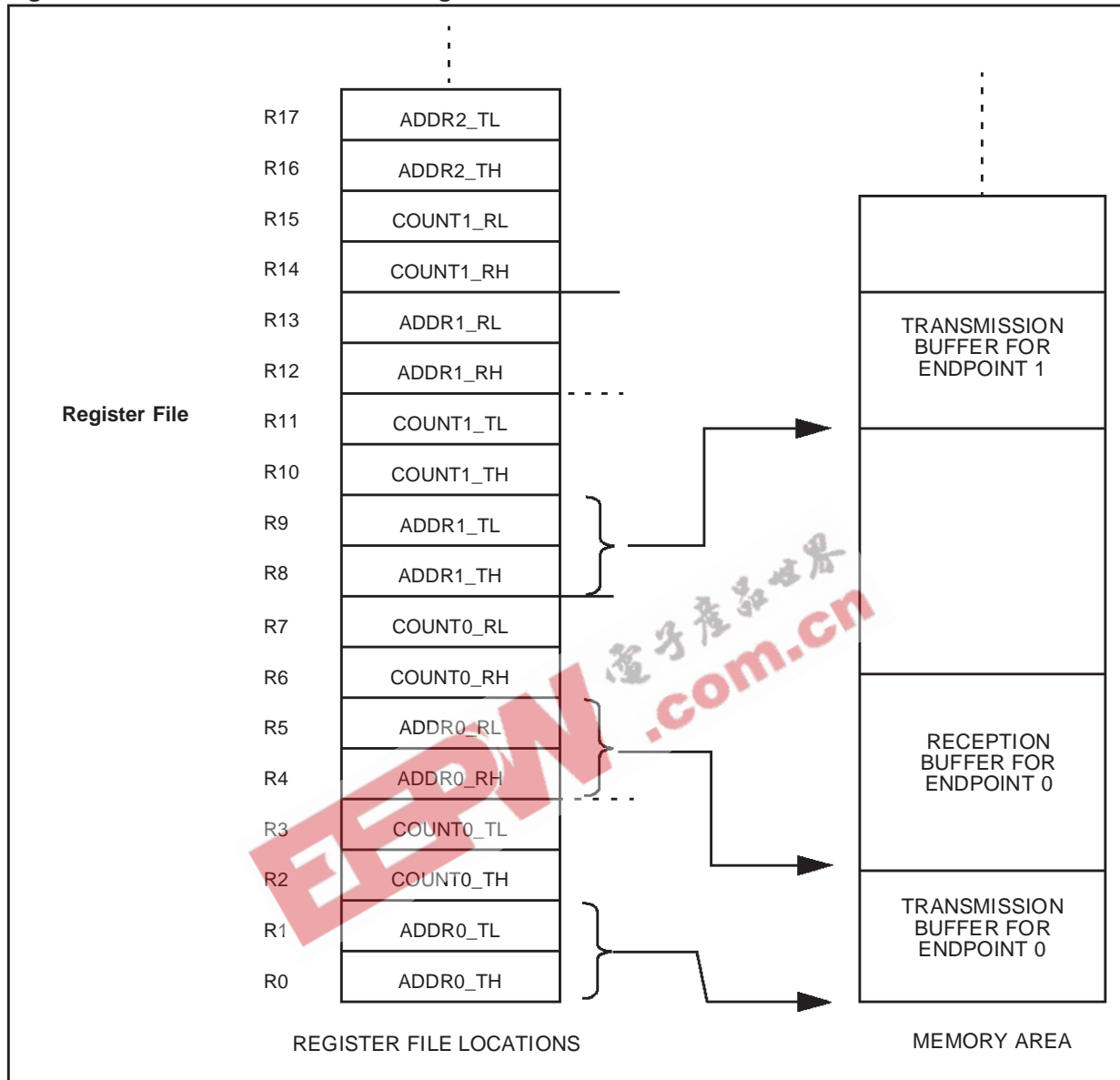

8.3.3.3 Interrupt modes

Two interrupt modes are available: single vector, where the application software has to poll the USB registers to determine which event required its attention, and multi-vector, where a specific interrupt vector is used for each endpoint. Special support is offered to isochronous transfers, implementing a swapped DMA buffer usage.

8.3.3.4 Suspend mode

The unit can be placed in low-power mode (SUSPEND mode), by writing in a control register. At this time, all static power dissipation is avoided, except for the generation of the 3.3V supply for the external pull-up resistor. The detection of activity at the USB inputs while in low-power mode wakes the device up asynchronously. A special interrupt source, ESUSP, is connected directly to a wake-up line so as to allow the ST9 to exit from HALT condition.

USB INTERFACE (Cont'd)

8.3.4 Register Description

USB registers can be divided into three groups:

- Common registers (page 15): interrupt registers and USB control registers.
- Function and endpoint registers (pages 15, 4 and 5 depending on how many endpoints are implemented): USB function addresses and endpoint status/configurations.
- Extra registers (page 60): device configuration.

8.3.4.1 Common registers

These registers affect all endpoints in the USB interface. They are all mapped in the same ST9 register page (page number 15).

The USB interface implements vectorized interrupts: through a vector table it is possible to automatically identify the starting address of each Interrupt Service Routine. The vector table contains the 16-bit addresses pointing to each of the interrupt service routines related to the CTR interrupt for each endpoint. Other two 8-bit locations are used to store the address of the service routine handling the interrupts described in the USBISTR register. When an interrupt request is acknowledged, the USBIVR register provides a vector pointing to the location in the vector table, containing the start address of the interrupt service routine related to the serviced interrupt.

INTERRUPT VECTOR REGISTER (USBIVR)

R248 - Read/Write

Register page: 15

Reset Value: xxxx xxx0 (xxh)

7								0
A1	A0	CTRO	V3	V2	V1	V0	0	

This register may be used in two different ways depending on the value of the SDNAV bit in the CTRL register.

- If SDNAV bit = 1, Bits 7:1 are user programmable (bit 0 is fixed to 0). The software writes the address of a vector pointing to a single interrupt routine. The application program has to select the routine related to the pending interrupts using the USBISTR and CTRINF registers.

- If SDNAV = 0, this register is used as a vector pointing to the 16-bit interrupt vectors in program memory containing the start addresses of the interrupt service routines related to the occurred interrupt. If several interrupts are simultaneously pending, hardware writes in this register the interrupt routine address related to the highest priority pending interrupt.

In this case the meaning of each bit is:

Bits 7:6 = **A[1:0]**: *Vector table Address*.

These two bits are user programmable and they contain the two most significant bits of the interrupt vector table. This allows the user to define the interrupt vector table position inside the first 256 locations of program memory at 64 bytes boundary.

Bit 5 = **CTRO**: *Correct Transfer interrupt occurred*.

0: CTR interrupt pending

1: One of the interrupt flags in the USBISTR register is pending

Note: If several interrupts are simultaneously pending, hardware writes this bit according to their relative priorities as listed below starting from the highest priority one to the lowest priority one:

- DMA Over/Underrun (see Table 24 and USBISTR register description)
- Correct Transfer on isochronous endpoints (see EPnRA register description)
- Correct Transfer on non-isochronous endpoints (see EPnRA register description)
- Notification events (see Table 24 and USBISTR register description).

Bits 4:1 = **V[3:1]**: *Endpoint Vector*.

If CTRO = 1, these bits are written by hardware to specify the endpoint identifier which has generated the CTR interrupt request.

If several CTR interrupts are pending, hardware writes the endpoint identifier related to the endpoint with the highest priority. Endpoint priority is defined according to the following rule: endpoint 0 has the highest priority, then endpoint 1 follows and so on up to the highest endpoint register pair (EP15) with the lowest priority.

If CTRO = 0, these bits are fixed to 1. In this case only one interrupt vector is used for all the interrupts defined in the USBISTR register.

USB INTERFACE (Cont'd)

Bit 0 = Reserved. This bit is fixed by hardware at 0.

Bit 7 = Reserved. This bit is fixed by hardware at 0.

INTERRUPT STATUS REGISTER (USBISTR)

R249 - Read/Write

Register page: 15

Reset Value: 0000 0000 (00h)

7							0
0	DOVR	ERR	ESUSP	SUSP	RESET	SOF	ESOF

Each bit is set by hardware when the related event occurs.

If one of these bits is set, the hardware clears the CTRO bit and sets the V[3:0] bits in the USBIVR register. In this way the USBIVR register will point to the interrupt vector containing the address of the service routine related to these interrupt sources. If several bits are set only a single interrupt will be generated.

Note: to avoid spurious clearing of some bits, it is recommended to clear them with a load instruction where all bits which must not be altered are set to 1, and all bits to be cleared are set to 0. Read-modify-write instructions like AND, XOR,... are to be avoided: consider the case of clearing bit 0 of USBISTR with an AND instruction, when only bit 7 of USBISTR is at 1 and the others at 0. First the microcontroller reads the content of USBISTR (=10h), then it clears bit 7 and writes the result (=00h) in USBISTR. If between the read and the write operations another bit were set by hardware (e.g. bit 5), writing 00h would clear it before the microprocessor has the time to service the event.

Bit 6 = **DOVR**: DMA over/underrun.

ST9 processor has not been able to answer a DMA request in time and the USB FIFO buffer is full or empty depending on the transfer direction (reception or transmission).

The USB handles this event in the following way: during reception the ACK handshake packet is not sent, during transmission a bit-stuffing error is forced on the transmitted stream. In both cases the host will retry the transaction. The DOVR interrupt should never occur during normal operations.

Bit 5 = **ERR**: Error.

One of the errors listed below has occurred:

- **NANS**: No answer. The timeout for a host response has expired.
- **CRC**: CRC error. One of the received CRCs, either in the token or in the data, was wrong.
- **BST**: Bit Stuffing error. A bit stuffing error was detected anywhere in the PID, data, and/or CRC.
- **FVIO**: Framing format violation. A nonstandard frame was received (EOP not in the right place, wrong token sequence, etc.).
- **BUFOVR**: Buffer overrun. A packet longer than the allocated DMA buffer has been received.

Table 24. Classification of Interrupt Sources:

Interrupt	Class
DOVR	DMA Over/Underrun event
ERR	Notification event
ESUSP	Notification event
SUSP	Notification event
RESET	Notification event
SOF	Notification event
ESOF	Notification event

ST92163 - USB PERIPHERAL (USB)

USB INTERFACE (Cont'd)

Bit 4 = **ESUSP**: *End Suspend mode.*

0: No activity detected during Suspend mode
 1: USB activity is detected that wakes up the USB interface during suspend mode.

Note: This event asynchronously clears the LP_SUSP bit in the USBCTLR register and activates the WKUP15 internal wake-up line to notify the WUIMU (if STOP_CK_EN=1 in the DEVCONF1 register)

Bit 3 = **SUSP** *Suspend mode request.*

0: No Suspend mode request
 1: No USB traffic has been received for 3 ms.

Note: The suspend condition check is enabled immediately after any USB reset and is disabled by hardware when suspend mode is active (LP_SUSP = 1) until the end of resume sequence.

Bit 2 = **RESET**: *USB Reset request.*

0: No USB Reset received.
 1: USB Reset received.

Note: Device address and endpoint registers are reset by an USB reset.

Bit 1 = **SOF**: *Start Of Frame.*

0: No SOF packet received.
 1: SOF packet received.

Bit 0 = **ESOF**: *Expected Start Of Frame.*

0: No SOF packet missed
 1: SOF packet is expected but not received.

INTERRUPT MASK REGISTER (USBIMR)

R250 - Read/Write

Register page: 15

Reset Value: 0000 0000 (00h)

7							0
0	DOVR M	ERR M	ESUSP M	SUSP M	RESET M	SOF M	ESOF M

This register contains mask bits for all interrupt condition bits included in the USBISTR register.

Whenever one of the USBIMR bits is 1, if the corresponding USBISTR bit is 1, an interrupt request is generated. For an explanation of each bit, refer to the USBISTR register description.

INTERRUPT PRIORITY REGISTER (USBIPR)

R251- Read/Write

Register page: 15

Reset Value: 0xxx 0xxx (xxh)

7							0
IEE	PIECE 2	PIECE 1	PIECE 0	NIEE	PNIEN 2	PNIEN 1	PNIEN 0

Bit 7 = **IEE**: *Isochronous Endpoint Enable.*

Set by software to enable Isochronous Endpoints. This also enables CTR interrupts related to isochronous endpoints and DMA overrun interrupts.
 0: Isochronous endpoints disabled
 1: Isochronous endpoints enabled

Bits 6:4 = **PIECE[2:0]**: *Priority level on Isochronous Endpoint and DMA Over/Underrun.*

Set by software to define the priority level of the isochronous endpoint CTR events (0 is the highest priority).

Bit 3 = **NIEE**: *Non-Isochronous Endpoint Enable.*

Set by software to enable Non-Isochronous Endpoints. This also enables CTR interrupts related to non-isochronous (bulk, control, interrupt) endpoints.
 0: Non-Isochronous endpoints disabled
 1: Non-Isochronous endpoints enabled

Bits 2:0 = **PNIEN[2:0]**: *Priority level of Non Isochronous Endpoints and Notification.*

Set by software to define the priority level of non-isochronous endpoint (bulk, control, interrupt) CTR events. 0 is the highest priority.

USB INTERFACE (Cont'd)

Interrupt sources are classified according to the following table

CONTROL REGISTER (USBCTLR)

R252 - Read/Write

Register page: 15

Reset Value: 0001 0101 (15h)

7							0
0	TIM_	0	SDNAV	RESUME	PDWN	LP_	FRES
	SUSP					SUSP	

Bit 7 = Reserved. This bit is fixed by hardware at 0.

Bit 6 = **TIM_SUSP**: *Timed Suspend*.
 Set by software when the SUSP interrupt is received to enter "timed-suspend" state.
 0: Timed suspend inactive
 1: Timed suspend active. The USB interface operates as in suspend mode but clocks and static power dissipation in the analog transceiver are not stopped.

Bit 5 = Reserved.

Bit 4 = **SDNAV**: *Single/Multiple Vector Selection*.
 This bit is set by software to select the single or multiple interrupt vector mode.
 0: Multiple interrupt vector mode
 1: Single interrupt vector mode
 See USBIVR register description for detailed information.

Bit 3 = **RESUME**: *Resume request*.
 Set by software to send a Resume signal to the host.
 0: Resume signal not forced on USB data lines.
 1: Resume signal forced on USB data lines.

Bit 2 = **PDWN**: *Power Down*.
 Set by software to turn off the 3.3V on-chip voltage regulator that supplies the external pull-up resistor and the transceiver.

Note: As a consequence the voltage on both USB root port signal lines will drift to 0V because of the pull-down resistors in the upstream USB host or hub, generating a disconnect indication. At least 2 μ s are required until the 3.3V supply falls within specifications after this bit is cleared, depending on the value of the external bypass capacitor.

Bit 1 = **LP_SUSP**: *Low-power suspend*.
 Set by software to put the USB interface in "low-power suspend" state. This condition should be entered while in "timed suspend" state (TIM_SUSP=1).
 0: Low-power suspend inactive
 1: Low-power suspend active

Bit 0 = **FRES**: *Force USB Reset*.
 Set by software to force a reset of the USB interface, just like a RESET signal on the USB. The USB interface is held in RESET state until software clears this bit, and a "USB-RESET" interrupt is generated, if enabled.
 0: Reset not forced
 1: USB interface reset forced

USB INTERFACE (Cont'd)

CTR INTERRUPT FLAGS (CTRINF)

R253 - Read/Write

Register page: 15

Reset Value: 00xx xxx0 (xxh)

7							0
0	0	INTO	ENID3	ENID2	ENID1	ENID0	0

Note: This register is used only when the SDNAV bit is 1.

Bit 7:6 = Reserved. These bits are fixed by hardware at 0.

Bit 5 = **INTO**: *Interrupt occurred.*

Set by hardware when SDNAV = 1 in the same way as the CTRO bit in USBIVR register is set when SDNAV = 0.

Bit 4:1 = **ENID[3:0]**: *Endpoint identifier.*

Set by hardware when SDNAV = 1 in the same way as V[3:0] bits in USBIVR register are set when SDNAV = 0.

Bit 0 = Reserved. This bit is fixed by hardware at 0.

FRAME NUMBER REGISTER HIGH (FNRH)

R254 - Read-only

Register page: 15

Reset Value: 0000 0xxx (0xh)

7							0
RXDP	RXDM	LCK	LSOF1	LSOF0	FN10	FN9	FN8

Bit 7 = **RXDP**.

Set/cleared by hardware to indicate D+ upstream port data line status.

Bit 6 = **RXDM**.

Set/cleared by hardware to indicate D- upstream port data line status.

Bit 5 = **LCK**: *Locked.*

Set by hardware when at least two consecutive SOF packets have been received after the end of a USB reset condition or after the end of a USB resume sequence.

0: Frame timer not locked

1: Frame timer locked

Note: Once locked, the frame timer remains in this state until a USB reset or USB suspend event occurs.

Bits 4:3 = **LSOF[1:0]**: *Lost SOF.*

Set by hardware when an ESOF interrupt is generated, counting the number of consecutive SOF packets lost. On reception of a SOF packet, these bits are cleared.

Bits 2:0 = **FN[10:8]**: *Frame Number bits 10:8.*

These bits contain the most significant bits of the Frame number received with the last received SOF packet. These bits are updated when a SOF interrupt is generated.

FRAME NUMBER REGISTER LOW (FNRL)

R255 - Read-only

Register page: 15

Reset Value: xxxx xxxx (xxh)

7							0
FN7	FN6	FN5	FN4	FN3	FN2	FN1	FN0

Bits 7:0 = **FN[7:0]**: *Frame Number bits 7:0.*

Set by hardware, this register contains the least significant bits of the 11-bit frame number contained in the last received SOF packet. The 3 remaining most significant bits are stored in the FNRH register. This register is updated when a SOF interrupt is generated.

8.3.4.2 Device and Endpoint specific Registers

For each function a DADDR register is available to store the device address and for each endpoint a pair of EPnR registers is available to store endpoint specific information.

USB INTERFACE (Cont'd)

DEVICE n ADDRESS (DADDRn)

R240 to R247 - Read/Write

Register page: 15

Reset Value: 0000 0000 (00h)

7								0
EF	ADD6	ADD5	ADD4	ADD3	ADD2	ADD1	ADD0	

Note: This register is also reset when a USB reset is received from the USB bus or forced through bit FRES in the USBCTLR register.

Bit 7 = **EF**: *Enable Function*.

Set by software to enable the USB function whose address is contained in the following ADD[6:0] bits.

0: Function disabled

1: Function enabled

Bits 6:0 = **ADD[6:0]**: *Device Address*.

Software must write into these bits the USB device address assigned by the host PC during the enumeration.

ENDPOINT n REGISTER A (EPnRA) (TRANSMISSION)

R240-R254 (even)

Read/Write

Register pages: 4 & 5

Reset value: 0000 0000 (00h)

7								0
CTR	DTOG_TX	STAT_TX1	STAT_TX0	PIDR1	PIDR0	CEP	ISO	

These registers are used for controlling data transmission. They are also reset when a USB reset is received or forced through the FRES bit in the USBCTLR register.

Note: The CTR bits are not affected by a USB reset

Each endpoint has its EPnRA register where n is the endpoint identifier in the range 0 to 15.

Bit 7 = **CTR**: *Correct Transfer*.

Set by hardware when a transaction is successfully completed on this endpoint; software can only clear this bit.

0: No correct transfer occurred

1: Correct transfer occurred

Note: A transaction ended with a NAK or STALL handshake does not set this bit, since no data is actually transferred, as in the case of protocol errors or data toggle mismatches. The CTR bit is also used to perform flow control: while CTR=1, a valid endpoint answers NAK to every transaction addressed to it (except SETUP requests which are simply ignored) until the application software acknowledges the CTR event, resetting this bit. This does not apply to isochronous endpoints where no handshake phase is used.

Bit 6 = **DTOG_TX**: *Data Toggle, for transmission transfers*.

If the endpoint is non-isochronous, this bit contains the required value of the data toggle bit (0=DATA0, 1=DATA1) for the next data packet to be transmitted. Hardware toggles this bit when the ACK handshake is received from the USB host, following a data packet transmission. If the endpoint is defined as a control one, hardware sets this bit to 1 on reception of a SETUP PID addressed to this endpoint.

If the endpoint is isochronous, this bit is used to support DMA buffer swapping since no data toggling is used for this sort of endpoint and only DATA0 packet are transmitted. Hardware toggles this bit just after the end of data packet transmission, since no handshake is used for isochronous transfers.

Note: this bit can be also written by software to initialize it (mandatory when the endpoint is not a control endpoint) or to force specific data toggle/DMA buffer usage.

USB INTERFACE (Cont'd)

Bit 5:4 = **STAT_TX [1:0]** *Status bits, for transmission transfers.*

These bits contain the information about the endpoint status, which are listed below:

Table 25. Transmission status encoding

STAT_TX [1:0]	Meaning
00	DISABLED: all transmission requests addressed to this endpoint are ignored.
01	STALL: the endpoint is stalled and all transmission requests result in a STALL handshake.
10	NAK: the endpoint is NAKed and all transmission requests result in a NAK handshake.
11	VALID: this endpoint is enabled for transmission.

These bits are written by software, but hardware sets the STAT_TX bits to NAK when a correct transfer has occurred (CTR=1) related to a IN or SETUP (control only) transaction addressed to this endpoint, waiting for the software to prepare the next set of data to be transmitted. If the endpoint is defined as isochronous, its status can be only "VALID" or "DISABLED" so no hardware change of the endpoint status will take place after a successful transaction.

Bits 3:2 = **PIDR[1:0]:** *PID Received.*

These bits are read-only and contain the two most significant bits of the PID field of the last token PID addressed to this endpoint.

These bits are kept frozen while CTR bit is at 1. The USB standard defines PIDR bits as in the following table:

Table 26. PID encoding

PIDR[1:0]	PID
00	OUT
10	IN
11	SETUP

Bit 1 = **CEP:** *Control Endpoint.*

Software must set this bit to configure this endpoint as a control endpoint.

0: Non-control endpoint

1: Control endpoint

Notes: If a control endpoint is defined as NAK in the receive direction, the USB interface will not answer, when a SETUP transaction is received.

If the control endpoint is defined as STALL in the receive direction, then the SETUP packet will be accepted anyway, transferring data and issuing the CTR interrupt.

Bit 0 = **ISO:** *Isochronous endpoint.*

Software must set this bit to configure this endpoint as an isochronous endpoint.

0: Not an isochronous endpoint

1: isochronous endpoint

Note: Since isochronous transfer has no handshake phase, the only legal values for the STAT_RX/STAT_TX bit pairs are '00' (Disabled) and '11' (Valid), any other value will produce results not compliant to the USB standard. Isochronous endpoints implement double-buffering, using both 'transmission' and 'reception' memory areas to manage buffer swapping on each successful transaction.

The memory buffer that is currently used by the USB interface is defined by the DTOG bit corresponding to the endpoint direction (DTOG_RX in EPnRB for 'reception' isochronous endpoints, DTOG_TX in EPnRA for 'transmission' isochronous endpoints) according to the following table:

Table 27. Isochronous memory buffers usage

DTOG bit value	DMA buffer used by USB Interface	DMA buffer used by application software
0	ADDRn_T / COUNTn_T register file locations.	ADDRn_R / COUNTn_R register file locations.
1	ADDRn_R / COUNTn_R register file locations.	ADDRn_T / COUNTn_T register file locations.

Since the swapped buffer management requires the usage of all 8 Register File locations hosting the address pointer and the length of the allocated memory buffers, isochronous endpoints are forced to be unidirectional so it is not possible to enable an isochronous endpoint both for transmission and reception.

USB INTERFACE (Cont'd)

**ENDPOINT n REGISTER B (EPnRB)
(RECEPTION)**

R241-R255 (odd) - Read/Write
Register pages: 4 & 5
Reset value: 0000 0000 (00h)

7							0
ST_OUT	DTOG_RX	STAT_RX1	STAT_RX0	EnA3	EnA2	EnA1	EnA0

These registers are used for controlling data reception. They are also reset when a USB reset is received from the USB bus or forced through bit FRES in the USBCTLR register. Each endpoint has its EPnRB register where n is the endpoint identifier in the range 0 to 15.

Bit 7 = **ST_OUT** *Status out.*

This bit is set by software to indicate that a status out transaction is expected: in this case all OUT transactions containing more than zero data bytes are answered STALL instead of ACK. This bit may be used to improve the robustness of the application to protocol errors during control transfers and its usage is intended on control endpoints only. When ST_OUT is reset, OUT transactions can have any number of bytes, as needed.

Bit 6 = **DTOG_RX**: *Data Toggle, for reception transfers.*

If the endpoint is non-isochronous, this bit contains the expected value of the data toggle bit (0=DATA0, 1=DATA1) for the next data packet to be received. Hardware toggles this bit when the ACK handshake is sent to the USB host, following a data packet reception with a matching data PID value. If the endpoint is defined as a control endpoint, hardware resets this bit on reception of a SETUP PID addressed to this endpoint.

If the endpoint is isochronous, this bit is used to support DMA buffer swapping since no data toggling is used for this sort of endpoint and only DATA0 packets are received. Hardware toggles this bit just after the end of data packet reception,

since no handshake is used for isochronous transfers.

Note: this bit can be also written by software to initialize it (mandatory when the endpoint is not a control endpoint) or to force a specific data toggle/DMA buffer usage.

Bit 5:4 = **STAT_RX [1:0]** *Status bits, for reception transfers.*

These bits contain the information about the endpoint status, as listed below:

Table 28. Reception status encoding

STAT_TX [1:0]	Meaning
00	DISABLED: all reception requests addressed to this endpoint are ignored.
01	STALL: the endpoint is stalled and all reception requests result in a STALL handshake.
10	NAK: the endpoint is naked and all reception requests result in a NAK handshake.
11	VALID: this endpoint is enabled for reception.

These bits are written by software, but hardware sets the STAT_RX bits to NAK when a correct transfer has occurred (CTR=1) related to a OUT or SETUP (control only) transaction addressed to this endpoint, so software has time to interpret the received data before acknowledging a new transaction.

If the endpoint is defined as isochronous, its status can be only "VALID" or "DISABLED" so no hardware change of the endpoint status will take place after a successful transaction.

Bit 3:0 = **EnA[3:0]** *Endpoint n Address, bits 3-0.* Software must write in this field the 4-bit address used to identify the transactions directed to this endpoint. A value must be written before enabling the corresponding endpoint.

USB INTERFACE (Cont'd)

8.3.4.3 Miscellaneous Registers

These registers contain device configuration parameters or optional functions of USB interface.

DEVICE CONFIGURATION 1 (DEVCONF1)

R244 - Read/Write
 Register page: 60
 Reset value: 0000 1111 (0Fh)

7							0
0	-	USBOE _EN	LS_ DEVICE	1	1	1	1

This register contains device configuration data that should be written by the software at the beginning of the application program and should never be changed during normal operations.

Bit 7:6 = Reserved. This bit is fixed by hardware at 0.

Bit 6 = Reserved. Must be kept at 0.

Bit 5 = **USBOE_EN**: *USBOE Signal Enable*.
 Set by software to enable the alternate output function connected to the upstream output enable signal.
 1: USBOE signal output enabled
 0: USBOE signal output disabled

Bit 4 = Reserved.

Bits 3:0 = Reserved. These bits are fixed by hardware at 1.

DEVICE CONFIGURATION 2 (DEVCONF2)

R245 - Read/Write
 Register page: 60
 Reset value: 0000 0000 (00h)

7								0
0	0	0	0	0	0	0	LVD_ DISABLE	SOFP_ ENABLE

This register contains device configuration data that should be written by the software at the beginning of the application program and should never be changed during normal operations.

Bits 7:2 = Reserved. These bits must be always written to 0.

Bit 1 = **LVD_DISABLE**: *Low Voltage Detector Disable*
 Set by the software to disable the generation of the device reset signal by the LVD.
 1: LVD disabled
 0: LVD enabled

If this bit is at 0, an internal reset can be issued both by the external RESET pin and the LVD when it detects a low supply voltage; if this bit is at 1 only the external pad can start a device reset.

Note: this bit can be only set to 1 by software, writing 0 has no effect and the LVD can be re-enabled only using a device reset.

USB INTERFACE (Cont'd)

Bit 0 = **SOFP_ENABLE**: *Start-Of-Frame Pulse Enable*.

Set by software to enable the use of the USBSOF alternate output function.

1: USBSOF alternate function enabled
0: USBSOF output disabled

USBSOF outputs a 333.33 ns long pulse at each frame start (actually 10 bits before the SOF packet expected start). This pulse is not generated until two SOF packets are received after any USB reset or USB resume (frame timer locking) and they stop as soon as the suspend condition is entered (TIM_SUSP bit in USBCTLR register).

MIRROR REGISTER A (MIRRA)

R246 - Read/Write

Register page: 60

Reset value: xxxx xxxx (xxh)

7							0
MIRA7	MIRA6	MIRA5	MIRA4	MIRA3	MIRA2	MIRA1	MIRA0

Bit 7:0 = **MIRA[7:0]** *Mirror register A, bits 7-0*.

This register acts as a bit mirroring location where software can write a byte and read it back with the LSB and MSB position swapped.

MIRROR REGISTER B (MIRRB)

R247 - Read/Write

Register page: 60

Reset value: xxxx xxxx (xxh)

7							0
MIRB7	MIRB6	MIRB5	MIRB4	MIRB3	MIRB2	MIRB1	MIRB0

Bit 7:0 = **MIRB[7:0]** *Mirror register B, bits 7-0*.

This register acts as a bit mirroring location where software can write a byte and read it back with the LSB and MSB position swapped.

ST92163 - USB PERIPHERAL (USB)

USB INTERFACE (Cont'd)

8.3.5 Register pages summary

The registers are located in different register file pages. To help finding the correct page for each

register, the following tables show the page mapping of all USB registers.

Table 29. USB Register Page Mapping

Address	Page 4	Page 5	Page 15	Page 60
240 (F0h)	EP0RA	EP8RA	DADDR0	
241 (F1h)	EP0RB	EP8RB	DADDR1	
242 (F2h)	EP1RA	EP9RA	DADDR2	
243 (F3h)	EP1RB	EP9RB	DADDR3	
244 (F4h)	EP2RA	EP10RA	DADDR4	DEVCONF1
245 (F5h)	EP2RB	EP10RB	DADDR5	DEVCONF2
246 (F6h)	EP3RA	EP11RA	DADDR6	MIRRA
247 (F7h)	EP3RB	EP11RB	DADDR7	MIRRB
248 (F8h)	EP4RA	EP12RA	USBIVR	
249 (F9h)	EP4RB	EP12RB	USBISTR	
250 (FAh)	EP5RA	EP13RA	USBIMR	
251 (FBh)	EP5RB	EP13RB	USBIPR	
252 (FCh)	EP6RA	EP14RA	USBCTLR	
253 (FDh)	EP6RB	EP14RB	CTRINF	
254 (FEh)	EP7RA	EP15RA	FNRH	
255 (FFh)	EP7RB	EP15RB	FNRL	

Table 30. USB Register page 15 Map and Reset Values

Reg. No.	Register Name	7	6	5	4	3	2	1	0
R240 - R247	DADDRn Reset Value	EF 0	ADD6 0	ADD5 0	ADD4 0	ADD3 0	ADD2 0	ADD1 0	ADD0 0
R248	USBIVR Reset Value	A1 x	A0 x	CTRO x	V3 x	V2 x	V1 x	V0 x	0 0
R249	USBISTR Reset Value	0 0	DOVR 0	DOVR 0	ESUSP 0	SUSP 0	RESET 0	SOF 0	ESOF 0
R250	USBIMR Reset Value	0 0	DOVRM 0	DOVRM 0	ESUSPM 0	SUSPM 0	RESETM 0	SOFM 0	ESOFM 0
R251	USBIPR Reset Value	IEE 0	PIECE2 x	PIECE1 x	PIECE0 x	NIEE 0	PNIEN2 x	PNIEN1 x	PNIEN0 x
R252	USBCTLR Reset Value	0 0	TIM_SUSP 0	0 0	SDNAV 1	RESUME 0	PDWN 1	LP_SUSP 0	FRES 1

ST92163 - USB PERIPHERAL (USB)

Reg. No.	Register Name	7	6	5	4	3	2	1	0
R253	CTRINF	0	0	INTO	ENID3	ENID2	ENID1	ENID0	0
	Reset Value	0	0	x	x	x	x	x	0
R254	FNRH	RXDP	RXDM	LCK	LSOF1	LSOF0	FN10	FN9	FN8
	Reset Value	0	0	0	0	0	x	x	x
R255	FNRL	FN7	FN6	FN5	FN4	FN3	FN2	FN1	FN0
	Reset Value	x	x	x	x	x	x	x	x

EEPW.com.cn 电子產品世界

8.4 SERIAL COMMUNICATIONS INTERFACE (SCI)

8.4.1 Introduction

The Serial Communications Interface (SCI) offers full-duplex serial data exchange with a wide range of external equipment. The SCI offers four operating modes: Asynchronous, Asynchronous with synchronous clock, Serial expansion and Synchronous.

The SCI offers the following principal features:

- Full duplex synchronous and asynchronous operation.
- Transmit, receive, line status, and device address interrupt generation.
- Integral Baud Rate Generator capable of dividing the input clock by any value from 2 to $2^{16}-1$ (16 bit word) and generating the internal 16X data sampling clock for asynchronous operation or the 1X clock for synchronous operation.
- Fully programmable serial interface:
 - 5, 6, 7, or 8 bit word length.
 - Even, odd, or no parity generation and detection.
 - 0, 1, 1.5, 2, 2.5, 3 stop bit generation.
 - Complete status reporting capabilities.
 - Line break generation and detection.
- Programmable address indication bit (wake-up bit) and user invisible compare logic to support multiple microcomputer networking. Optional character search function.
- Internal diagnostic capabilities:
 - Local loopback for communications link fault isolation.
 - Auto-echo for communications link fault isolation.
- Separate interrupt/DMA channels for transmit and receive.
- In addition, a Synchronous mode supports:
 - High speed communication
 - Possibility of hardware synchronization (RTS/DCD signals).
 - Programmable polarity and stand-by level for data SIN/SOUT.
 - Programmable active edge and stand-by level for clocks CLKOUT/RXCLK.
 - Programmable active levels of RTS/DCD signals.
 - Full Loop-Back and Auto-Echo modes for DATA, CLOCKS and CONTROLS.

Figure 71. SCI Block Diagram

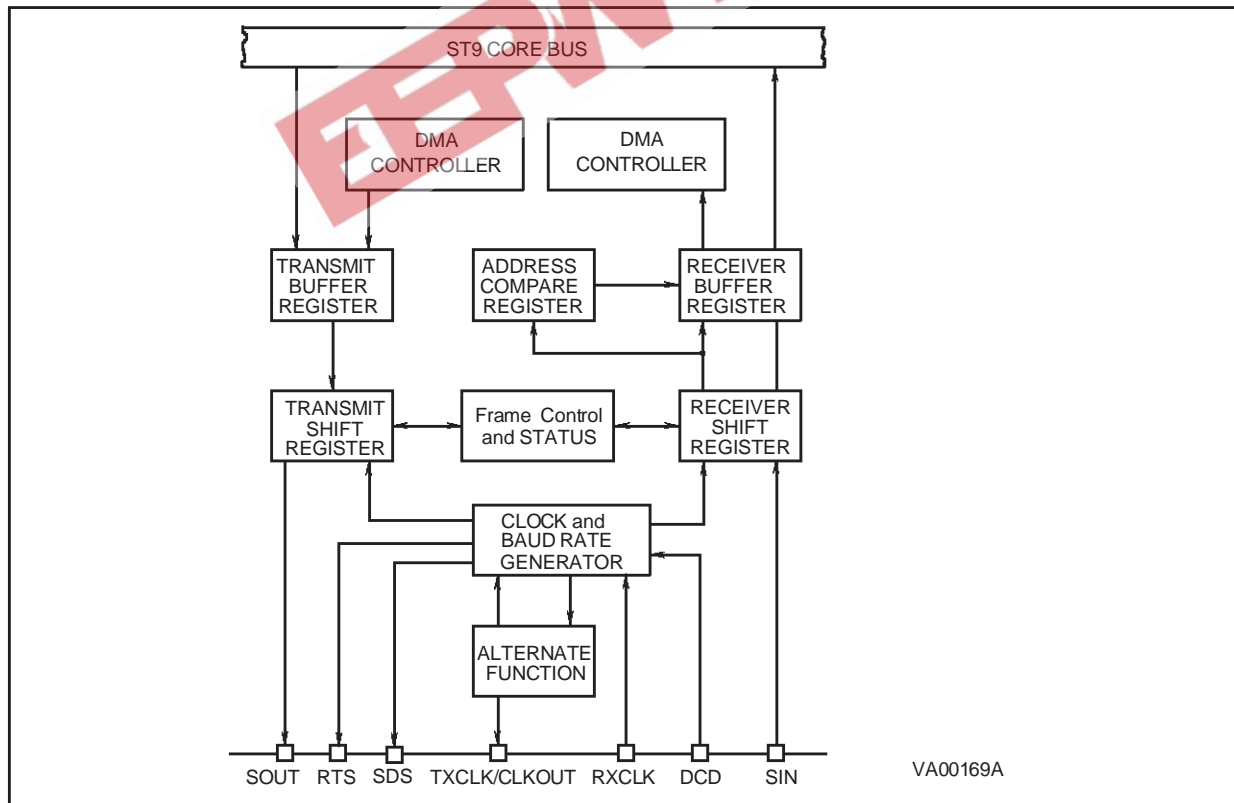

SERIAL COMMUNICATIONS INTERFACE (Cont'd)

8.4.2 Functional Description

The SCI offers four operating modes:

- Asynchronous mode
- Asynchronous mode with synchronous clock
- Serial expansion mode
- Synchronous mode

Asynchronous mode, Asynchronous mode with synchronous clock and Serial expansion mode output data with the same serial frame format. The differences lie in the data sampling clock rates (1X, 16X) and in the protocol used.

Figure 72. SCI Functional Schematic

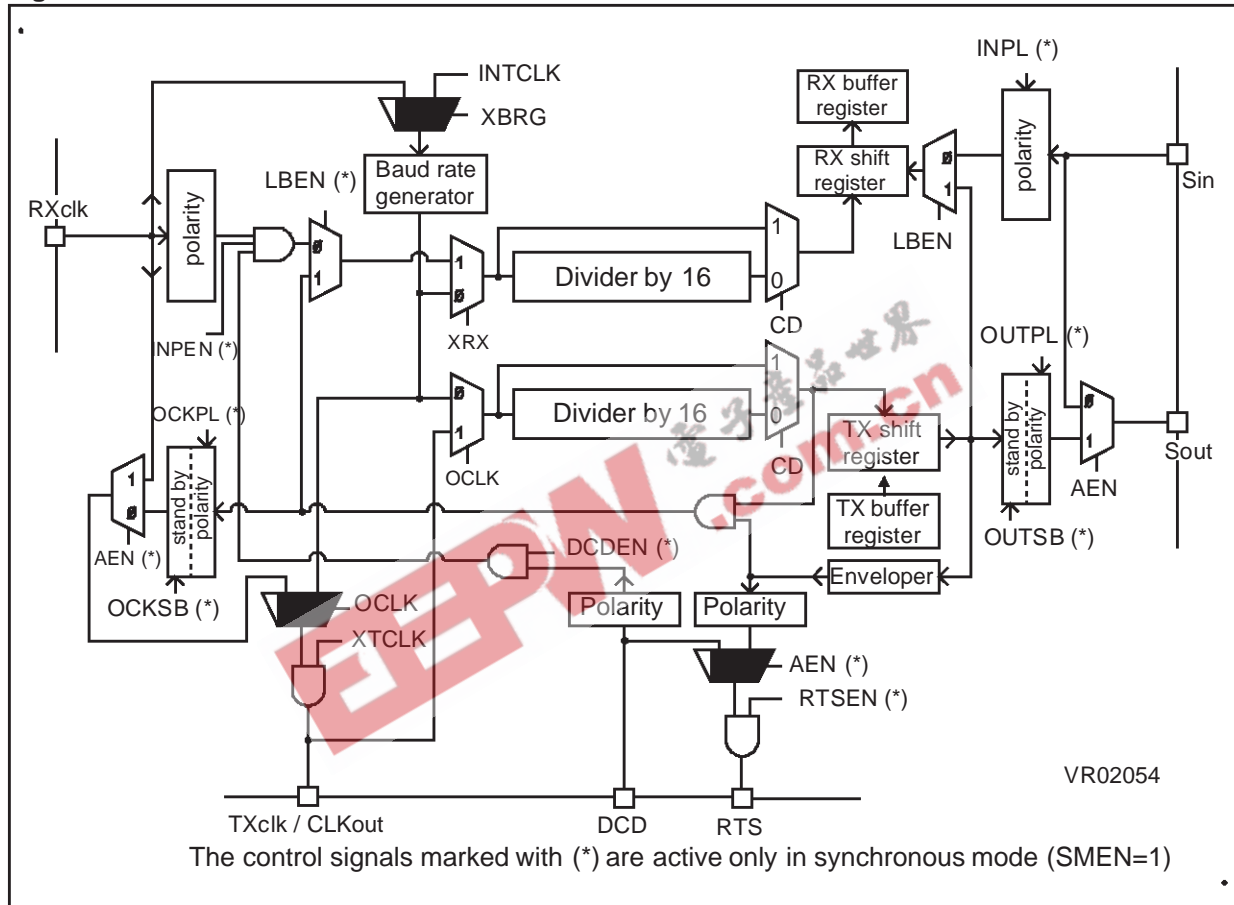

Note: Some pins may not be available on some devices. Refer to the device Pinout Description.

SERIAL COMMUNICATIONS INTERFACE (Cont'd)

8.4.3 SCI Operating Modes

8.4.3.1 Asynchronous Mode

In this mode, data and clock can be asynchronous (the transmitter and receiver can use their own clocks to sample received data), each data bit is sampled 16 times per clock period.

The baud rate clock should be set to the ÷16 Mode and the frequency of the input clock (from an external source or from the internal baud-rate generator output) is set to suit.

8.4.3.2 Asynchronous Mode with Synchronous Clock

In this mode, data and clock are synchronous, each data bit is sampled once per clock period.

For transmit operation, a general purpose I/O port pin can be programmed to output the CLKOUT signal from the baud rate generator. If the SCI is provided with an external transmission clock source, there will be a skew equivalent to two INTCLK periods between clock and data.

Data will be transmitted on the falling edge of the transmit clock. Received data will be latched into the SCI on the rising edge of the receive clock.

Figure 73. Sampling Times in Asynchronous Format

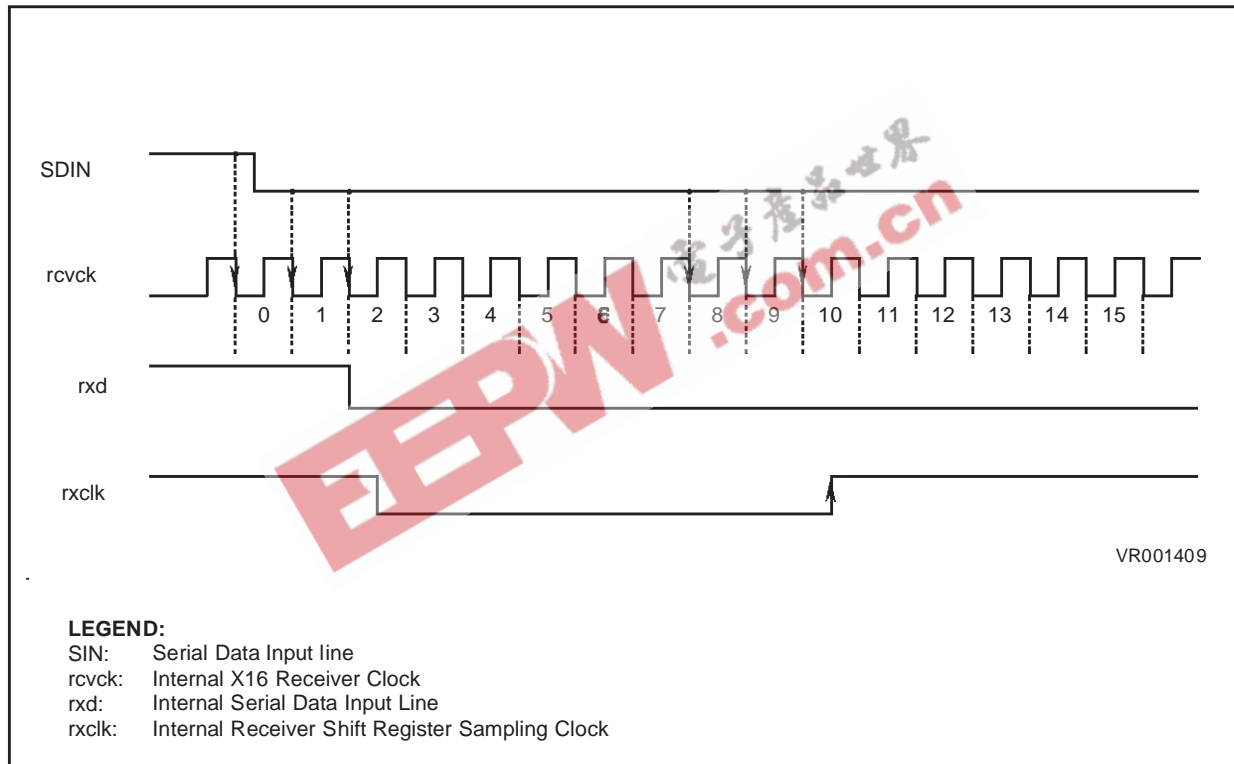

SERIAL COMMUNICATIONS INTERFACE (Cont'd)

8.4.3.3 Serial Expansion Mode

This mode is used to communicate with an external synchronous peripheral.

The transmitter only provides the clock waveform during the period that data is being transmitted on the CLKOUT pin (the Data Envelope). Data is latched on the rising edge of this clock.

Whenever the SCI is to receive data in serial port expansion mode, the clock must be supplied externally, and be synchronous with the transmitted data. The SCI latches the incoming data on the rising edge of the received clock, which is input on the RXCLK pin.

8.4.3.4 Synchronous Mode

This mode is used to access an external synchronous peripheral, dummy start/stop bits are not included in the data frame. Polarity, stand-by level and active edges of I/O signals are fully and separately programmable for both inputs and outputs.

It's necessary to set the SMEN bit of the Synchronous Input Control Register (SICR) to enable this mode and all the related extra features (otherwise disabled).

The transmitter will provide the clock waveform only during the period when the data is being transmitted via the CLKOUT pin, which can be enabled by setting both the XTCLK and OCLK bits of

the Clock Configuration Register. Whenever the SCI is to receive data in synchronous mode, the clock waveform must be supplied externally via the RXCLK pin and be synchronous with the data. For correct receiver operation, the XRX bit of the Clock Configuration Register must be set.

Two external signals, Request-To-Send and Data-Carrier-Detect (RTS/DCD), can be enabled to synchronise the data exchange between two serial units. The RTS output becomes active just before the first active edge of CLKOUT and indicates to the target device that the MCU is about to send a synchronous frame; it returns to its stand-by state following the last active edge of CLKOUT (MSB transmitted).

The DCD input can be considered as a gate that filters RXCLK and informs the MCU that a transmitting device is transmitting a data frame. Polarity of RTS/DCD is individually programmable, as for clocks and data.

The data word is programmable from 5 to 8 bits, as for the other modes; parity, address/9th, stop bits and break cannot be inserted into the transmitted frame. Programming of the related bits of the SCI control registers is irrelevant in Synchronous Mode: all the corresponding interrupt requests must, in any case, be masked in order to avoid incorrect operation during data reception.

SERIAL COMMUNICATIONS INTERFACE (Cont'd)

Figure 74. SCI Operating Modes

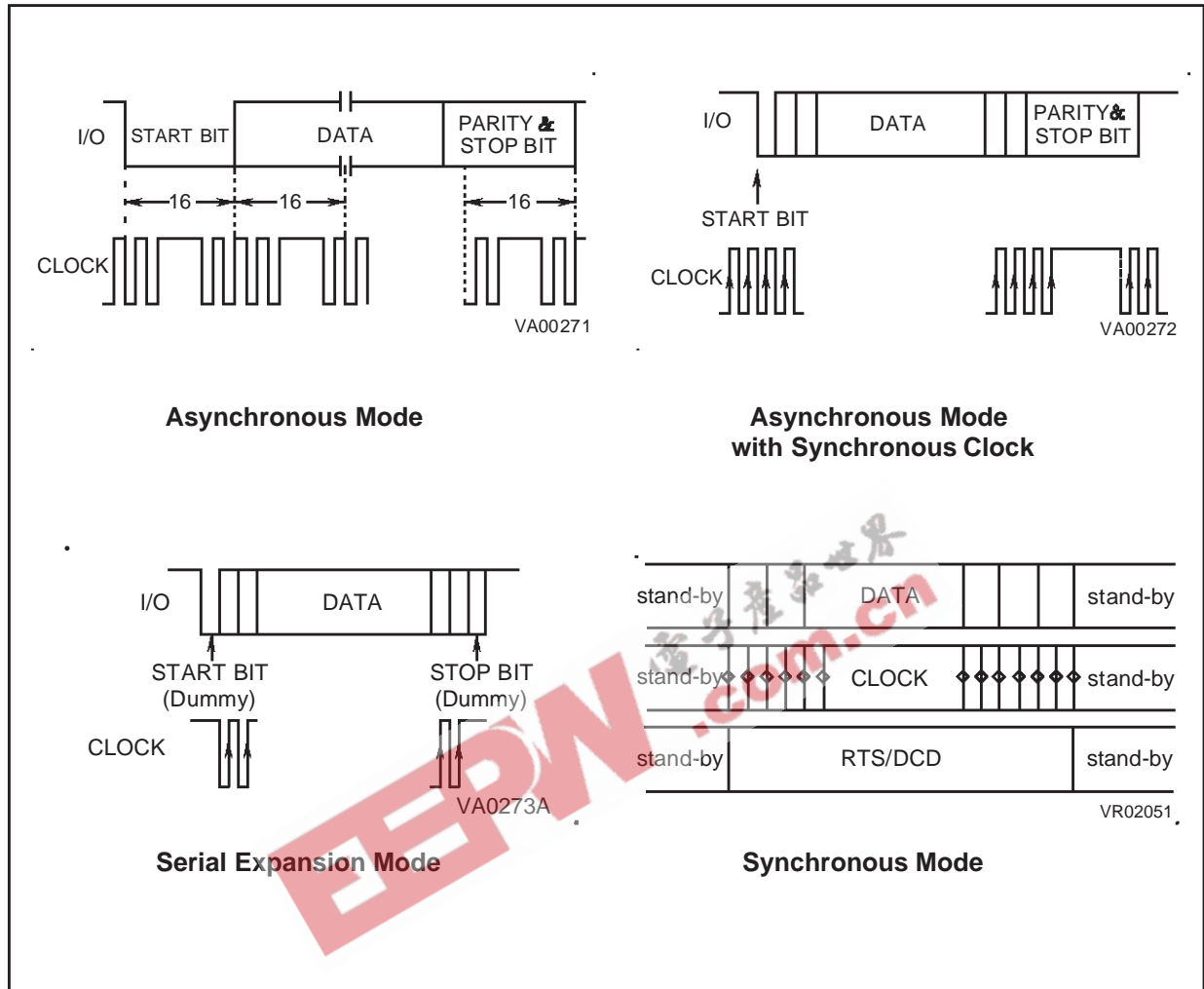

Note: In all operating modes, the Least Significant Bit is transmitted/received first.

SERIAL COMMUNICATIONS INTERFACE (Cont'd)

8.4.4 Serial Frame Format

Characters sent or received by the SCI can have some or all of the features in the following format, depending on the operating mode:

START: the START bit indicates the beginning of a data frame in Asynchronous modes. The START condition is detected as a high to low transition.

A dummy START bit is generated in Serial Expansion mode. The START bit is not generated in Synchronous mode.

DATA: the DATA word length is programmable from 5 to 8 bits, for both Synchronous and Asynchronous modes. LSB are transmitted first.

PARITY: The Parity Bit (not available in Serial Expansion mode and Synchronous mode) is optional, and can be used with any word length. It is used for error checking and is set so as to make the total number of high bits in DATA plus PARITY odd or even, depending on the number of "1"s in the DATA field.

ADDRESS/9TH: The Address/9th Bit is optional and may be added to any word format. It is used in

both Serial Expansion and Asynchronous modes to indicate that the data is an address (bit set).

The ADDRESS/9TH bit is useful when several microcontrollers are exchanging data on the same serial bus. Individual microcontrollers can stay idle on the serial bus, waiting for a transmitted address. When a microcontroller recognizes its own address, it can begin Data Reception, likewise, on the transmit side, the microcontroller can transmit another address to begin communication with a different microcontroller.

The ADDRESS/9TH bit can be used as an additional data bit or to mark control words (9th bit).

STOP: Indicates the end of a data frame in Asynchronous modes. A dummy STOP bit is generated in Serial Expansion mode. The STOP bit can be programmed to be 1, 1.5, 2, 2.5 or 3 bits long, depending on the mode. It returns the SCI to the quiescent marking state (i.e., a constant high-state condition) which lasts until a new start bit indicates an incoming word. The STOP bit is not generated in Synchronous mode.

Figure 75. SCI Character Formats

	START ⁽²⁾	DATA ⁽¹⁾	PARITY ⁽³⁾	ADDRESS ⁽²⁾	STOP ⁽²⁾	
# bits	1	5, 6, 7, 8	0, 1	0, 1	1, 1.5, 2, 2.5, 1, 2, 3	16X 1X
states			NONE ODD EVEN	ON OFF		

(1) LSB First

(2) Not available in Synchronous mode

(3) Not available in Serial Expansion mode
and Synchronous mode

SERIAL COMMUNICATIONS INTERFACE (Cont'd)

8.4.4.1 Data transfer

Data to be transmitted by the SCI is first loaded by the program into the Transmitter Buffer Register. The SCI will transfer the data into the Transmitter Shift Register when the Shift Register becomes available (empty). The Transmitter Shift Register converts the parallel data into serial format for transmission via the SCI Alternate Function output, Serial Data Out. On completion of the transfer, the transmitter buffer register interrupt pending bit will be updated. If the selected word length is less than 8 bits, the unused most significant bits do not need to be defined.

Incoming serial data from the Serial Data Input pin is converted into parallel format by the Receiver Shift Register. At the end of the input data frame, the valid data portion of the received word is transferred from the Receiver Shift Register into the Receiver Buffer Register. All Receiver interrupt conditions are updated at the time of transfer. If the selected character format is less than 8 bits, the unused most significant bits will be set.

The Frame Control and Status block creates and checks the character configuration (Data length and number of Stop bits), as well as the source of the transmitter/receiver clock.

The internal Baud Rate Generator contains a programmable divide by "N" counter which can be used to generate the clocks for the transmitter and/or receiver. The baud rate generator can use INTCLK or the Receiver clock input via RXCLK.

The Address bit/D9 is optional and may be added to any word in Asynchronous and Serial Expansion modes. It is commonly used in network or machine control applications. When enabled (AB set), an address or ninth data bit can be added to a transmitted word by setting the Set Address bit (SA). This is then appended to the next word entered into the (empty) Transmitter Buffer Register and then cleared by hardware. On character input, a set Address Bit can indicate that the data preceding the bit is an address which may be compared in hardware with the value in the Address Compare Register (ACR) to generate an Address Match interrupt when equal.

The Address bit and Address Comparison Register can also be combined to generate four different types of Address Interrupt to suit different protocols, based on the status of the Address Mode Enable bit (AMEN) and the Address Mode bit (AM) in the CHCR register.

The character match Address Interrupt mode may be used as a powerful character search mode, generating an interrupt on reception of a predetermined character e.g. Carriage Return or End of Block codes (Character Match Interrupt). This is the only Address Interrupt Mode available in Synchronous mode.

The Line Break condition is fully supported for both transmission and reception. Line Break is sent by setting the SB bit (IDPR). This causes the transmitter output to be held low (after all buffered data has been transmitted) for a minimum of one complete word length and until the SB bit is Reset. Break cannot be inserted into the transmitted frame for the Synchronous mode.

Testing of the communications channel may be performed using the built-in facilities of the SCI peripheral. Auto-Echo mode and Loop-Back mode may be used individually or together. In Asynchronous, Asynchronous with Synchronous Clock and Serial Expansion modes they are available only on SIN/SOUT pins through the programming of AEN/LBEN bits in CCR. In Synchronous mode (SMEN set) the above configurations are available on SIN/SOUT, RXCLK/CLKOUT and DCD/RTS pins by programming the AEN/LBEN bits and independently of the programmed polarity. In the Synchronous mode case, when AEN is set, the transmitter outputs (data, clock and control) are disconnected from the I/O pins, which are driven directly by the receiver input pins (Auto-Echo mode: SOUT=SIN, CLKOUT=RXCLK and RTS=DCD, even if they act on the internal receiver with the programmed polarity/edge). When LBEN is set, the receiver inputs (data, clock and controls) are disconnected and the transmitter outputs are looped-back into the receiver section (Loop-Back mode: SIN=SOUT, RXCLK=CLKOUT, DCD=RTS. The output pins are locked to their programmed stand-by level and the status of the INPL, XCKPL, DCDPL, OUTPL, OCKPL and RTSPL bits in the SICR register are irrelevant). Refer to Figure 6, Figure 7, and Figure 8 for these different configurations.

Table 31. Address Interrupt Modes

If 9th Data Bit is set ⁽¹⁾
If Character Match
If Character Match and 9th Data Bit is set ⁽¹⁾
If Character Match Immediately Follows BREAK ⁽¹⁾

⁽¹⁾ Not available in Synchronous mode

SERIAL COMMUNICATIONS INTERFACE (Cont'd)

Figure 76. Auto Echo Configuration

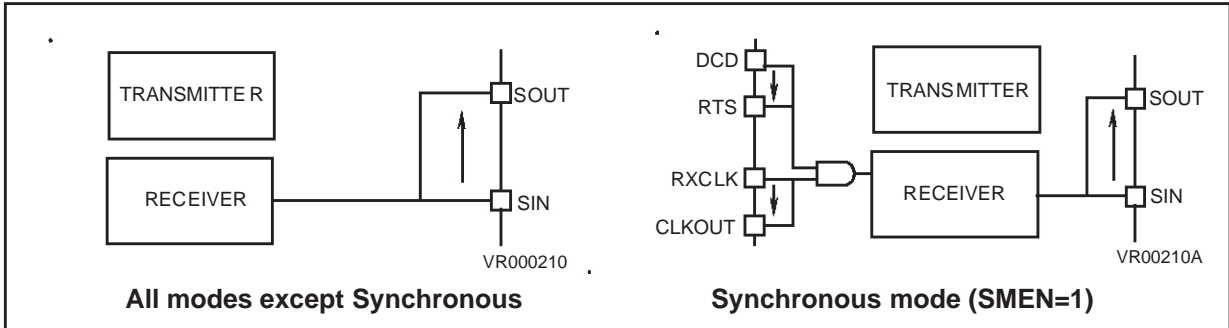

Figure 77. Loop Back Configuration

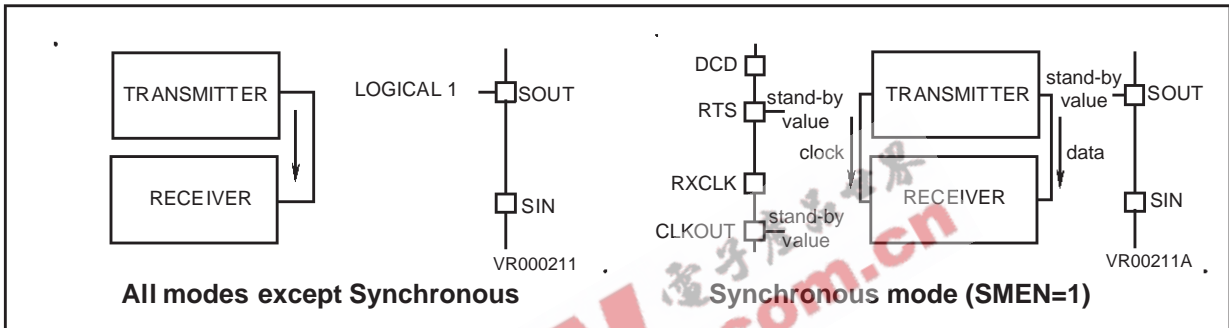
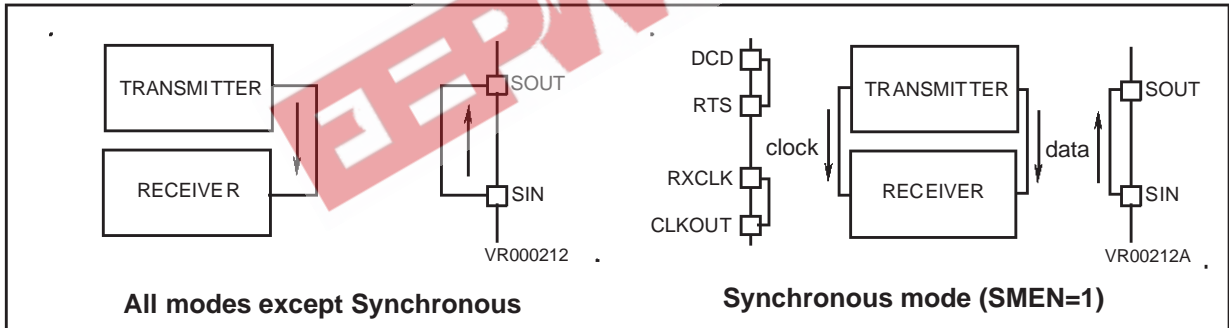

Figure 78. Auto Echo and Loop-Back Configuration



SERIAL COMMUNICATIONS INTERFACE (Cont'd)

8.4.5 Clocks And Serial Transmission Rates

The communication bit rate of the SCI transmitter and receiver sections can be provided from the internal Baud Rate Generator or from external sources. The bit rate clock is divided by 16 in Asynchronous mode (CD in CCR reset), or undivided in the 3 other modes (CD set).

With INTCLK running at 24MHz and no external Clock provided, a maximum bit rate of 3MBaud and 750KBaud is available in undivided and divide by-16-mode respectively.

With INTCLK running at 24MHz and an external Clock provided through the RXCLK/TXCLK lines, a maximum bit rate of 3MBaud and 375KBaud is available in undivided and divided by 16 mode respectively (see Figure 10 "Receiver and Transmitter Clock Frequencies")

External Clock Sources. The External Clock input pin TXCLK may be programmed by the XTCLK and OCLK bits in the CCR register as: the transmit clock input, Baud Rate Generator output (allowing an external divider circuit to provide the receive clock for split rate transmit and receive), or as CLKOUT output in Synchronous and Serial Expansion modes. The RXCLK Receive clock input is enabled by the XRX bit, this input should be set in accordance with the setting of the CD bit.

Baud Rate Generator. The internal Baud Rate Generator consists of a 16-bit programmable divide by "N" counter which can be used to generate the transmitter and/or receiver clocks. The minimum baud rate divisor is 2 and the maximum divisor is $2^{16}-1$. After initialising the baud rate generator, the divisor value is immediately loaded into the counter. This prevents potentially long random counts on the initial load.

The Baud Rate generator frequency is equal to the Input Clock frequency divided by the Divisor value.

WARNING: Programming the baud rate divider to 0 or 1 will stop the divider.

The output of the Baud Rate generator has a precise 50% duty cycle. The Baud Rate generator can use INTCLK for the input clock source. In this case, INTCLK (and therefore the MCU Xtal) should be chosen to provide a suitable frequency for division by the Baud Rate Generator to give the required transmit and receive bit rates. Suitable INTCLK frequencies and the respective divider values for standard Baud rates are shown in Table 2.

8.4.6 SCI Initialization Procedure

Writing to either of the two Baud Rate Generator Registers immediately disables and resets the SCI baud rate generator, as well as the transmitter and receiver circuitry.

After writing to the second Baud Rate Generator Register, the transmitter and receiver circuits are enabled. The Baud Rate Generator will load the new value and start counting.

To initialize the SCI, the user should first initialize the most significant byte of the Baud Rate Generator Register; this will reset all SCI circuitry. The user should then initialize all other SCI registers (SICR/SOCR included) for the desired operating mode and then, to enable the SCI, he should initialize the least significant byte Baud Rate Generator Register.

'On-the-Fly' modifications of the control registers' content during transmitter/receiver operations, although possible, can corrupt data and produce undesirable spikes on the I/O lines (data, clock and control). Furthermore, modifying the control registers' content without reinitialising the SCI circuitry (during stand-by cycles, waiting to transmit or receive data) must be kept carefully under control by software to avoid spurious data being transmitted or received.

Note: For synchronous receive operation, the data and receive clock must not exhibit significant skew between clock and data. The received data and clock are internally synchronized to INTCLK.

Figure 79. SCI Baud Rate Generator Initialization Sequence

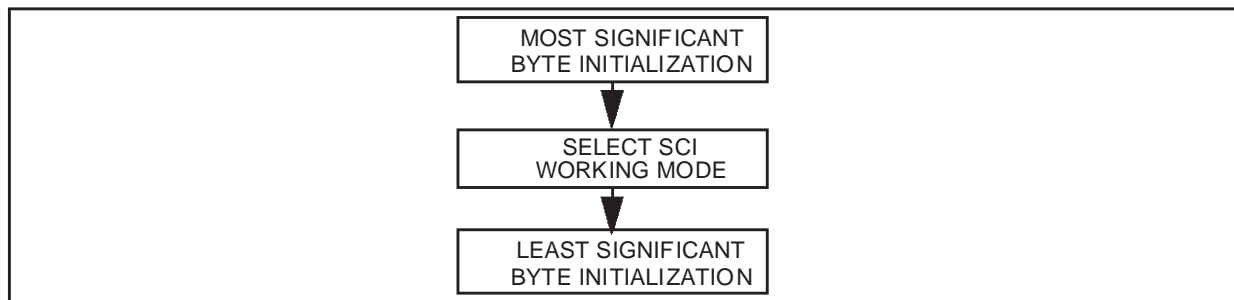

ST92163 - SERIAL COMMUNICATIONS INTERFACE (SCI)

SERIAL COMMUNICATIONS INTERFACE (Cont'd)

Table 32. SCI Baud Rate Generator Divider Values Example 1

INTCLK: 19660.800 KHz							
Baud Rate	Clock Factor	Desired Freq (kHz)	Divisor		Actual Baud Rate	Actual Freq (kHz)	Deviation
			Dec	Hex			
50.00	16 X	0.80000	24576	6000	50.00	0.80000	0.0000%
75.00	16 X	1.20000	16384	4000	75.00	1.20000	0.0000%
110.00	16 X	1.76000	11170	2BA2	110.01	1.76014	-0.00081%
300.00	16 X	4.80000	4096	1000	300.00	4.80000	0.0000%
600.00	16 X	9.60000	2048	800	600.00	9.60000	0.0000%
1200.00	16 X	19.20000	1024	400	1200.00	19.20000	0.0000%
2400.00	16 X	38.40000	512	200	2400.00	38.40000	0.0000%
4800.00	16 X	76.80000	256	100	4800.00	76.80000	0.0000%
9600.00	16 X	153.60000	128	80	9600.00	153.60000	0.0000%
19200.00	16 X	307.20000	64	40	19200.00	307.20000	0.0000%
38400.00	16 X	614.40000	32	20	38400.00	614.40000	0.0000%
76800.00	16 X	1228.80000	16	10	76800.00	1228.80000	0.0000%

Table 33. SCI Baud Rate Generator Divider Values Example 2

INTCLK: 24576 KHz							
Baud Rate	Clock Factor	Desired Freq (kHz)	Divisor		Actual Baud Rate	Actual Freq (kHz)	Deviation
			Dec	Hex			
50.00	16 X	0.80000	30720	7800	50.00	0.80000	0.0000%
75.00	16 X	1.20000	20480	5000	75.00	1.20000	0.0000%
110.00	16 X	1.76000	13963	383B	110.01	1.76014	-0.00046%
300.00	16 X	4.80000	5120	1400	300.00	4.80000	0.0000%
600.00	16 X	9.60000	2560	A00	600.00	9.60000	0.0000%
1200.00	16 X	19.20000	1280	500	1200.00	19.20000	0.0000%
2400.00	16 X	38.40000	640	280	2400.00	38.40000	0.0000%
4800.00	16 X	76.80000	320	140	4800.00	76.80000	0.0000%
9600.00	16 X	153.60000	160	A0	9600.00	153.60000	0.0000%
19200.00	16 X	307.20000	80	50	19200.00	307.20000	0.0000%
38400.00	16 X	614.40000	40	28	38400.00	614.40000	0.0000%
76800.00	16 X	1228.80000	20	14	76800.00	1228.80000	0.0000%

SERIAL COMMUNICATIONS INTERFACE (Cont'd)

8.4.7 Input Signals

SIN: Serial Data Input. This pin is the serial data input to the SCI receiver shift register.

TXCLK: External Transmitter Clock Input. This pin is the external input clock driving the SCI transmitter. The TXCLK frequency must be greater than or equal to 16 times the transmitter data rate (depending whether the X16 or the X1 clock have been selected). A 50% duty cycle is required for this input and must have a period of at least twice INTCLK. The use of the TXCLK pin is optional.

RXCLK: External Receiver Clock Input. This input is the clock to the SCI receiver when using an external clock source connected to the baud rate generator. INTCLK is normally the clock source. A 50% duty cycle is required for this input and must have a period of at least twice INTCLK. Use of RXCLK is optional.

DCD: Data Carrier Detect. This input is enabled only in Synchronous mode; it works as a gate for the RXCLK clock and informs the MCU that an emitting device is transmitting a synchronous frame. The active level can be programmed as 1 or 0 and must be provided at least one INTCLK period before the first active edge of the input clock.

8.4.8 Output Signals

SOUT: Serial Data Output. This Alternate Function output signal is the serial data output for the SCI transmitter in all operating modes.

CLKOUT: Clock Output. The alternate Function of this pin outputs either the data clock from the transmitter in Serial Expansion or Synchronous modes, or the clock output from the Baud Rate Generator. In Serial expansion mode it will clock

only the data portion of the frame and its stand-by state is high: data is valid on the rising edge of the clock. Even in Synchronous mode CLKOUT will only clock the data portion of the frame, but the stand-by level and active edge polarity are programmable by the user.

When Synchronous mode is disabled (SMEN in SICR is reset), the state of the XTCLK and OCLK bits in CCR determine the source of CLKOUT; '11' enables the Serial Expansion Mode.

When the Synchronous mode is enabled (SMEN in SICR is set), the state of the XTCLK and OCLK bits in CCR determine the source of CLKOUT; '00' disables it for PLM applications.

RTS: Request To Send. This output Alternate Function is only enabled in Synchronous mode; it becomes active when the Least Significant Bit of the data frame is sent to the Serial Output Pin (SOUT) and indicates to the target device that the MCU is about to send a synchronous frame; it returns to its stand-by value just after the last active edge of CLKOUT (MSB transmitted). The active level can be programmed high or low.

SDS: Synchronous Data Strobe. This output Alternate function is only enabled in Synchronous mode; it becomes active high when the Least Significant Bit is sent to the Serial Output Pins (SOUT) and indicates to the target device that the MCU is about to send the first bit for each synchronous frame. It is active high on the first bit and it is low for all the rest of the frame. The active level can not be programmed.

Figure 80. Receiver and Transmitter Clock Frequencies

		Min	Max	Conditions
Receiver Clock Frequency	External RXCLK	0	INTCLK/8	1x mode
		0	INTCLK/4	16x mode
	Internal Receiver Clock	0	INTCLK/8	1x mode
		0	INTCLK/2	16x mode
Transmitter Clock Frequency	External TXCLK	0	INTCLK/8	1x mode
		0	INTCLK/4	16x mode
	Internal Transmitter Clock	0	INTCLK/8	1x mode
		0	INTCLK/2	16x mode

Note: The internal receiver and transmitter clocks are the ones applied to the Tx and Rx shift registers (see Figure 1).

SERIAL COMMUNICATIONS INTERFACE (Cont'd)

8.4.9 Interrupts and DMA

8.4.9.1 Interrupts

The SCI can generate interrupts as a result of several conditions. Receiver interrupts include data pending, receive errors (overrun, framing and parity), as well as address or break pending. Transmitter interrupts are software selectable for either Transmit Buffer Register Empty (BSN set) or for Transmit Shift Register Empty (BSN reset) conditions.

Typical usage of the Interrupts generated by the SCI peripheral are illustrated in Figure 11.

The SCI peripheral is able to generate interrupt requests as a result of a number of events, several of which share the same interrupt vector. It is therefore necessary to poll S_ISR, the Interrupt Status Register, in order to determine the active

trigger. These bits should be reset by the programmer during the Interrupt Service routine.

The four major levels of interrupt are encoded in hardware to provide two bits of the interrupt vector register, allowing the position of the block of pointer vectors to be resolved to an 8 byte block size.

The SCI interrupts have an internal priority structure in order to resolve simultaneous events. Refer also to Section 0.1.3 for more details relating to Synchronous mode.

Table 34. SCI Interrupt Internal Priority

Receive DMA Request	Highest Priority
Transmit DMA Request	
Receive Interrupt	Lowest Priority
Transmit Interrupt	

EEPW.com.cn 电子产品世界

SERIAL COMMUNICATIONS INTERFACE (Cont'd)

Table 35. SCI Interrupt Vectors

Interrupt Source	Vector Address
Transmitter Buffer or Shift Register Empty Transmit DMA end of Block	xxx x110
Received Data Pending Receive DMA end of Block	xxxx x100
Break Detector Address Word Match	xxxx x010
Receiver Error	xxxx x000

Figure 81. SCI Interrupts: Example of Typical Usage

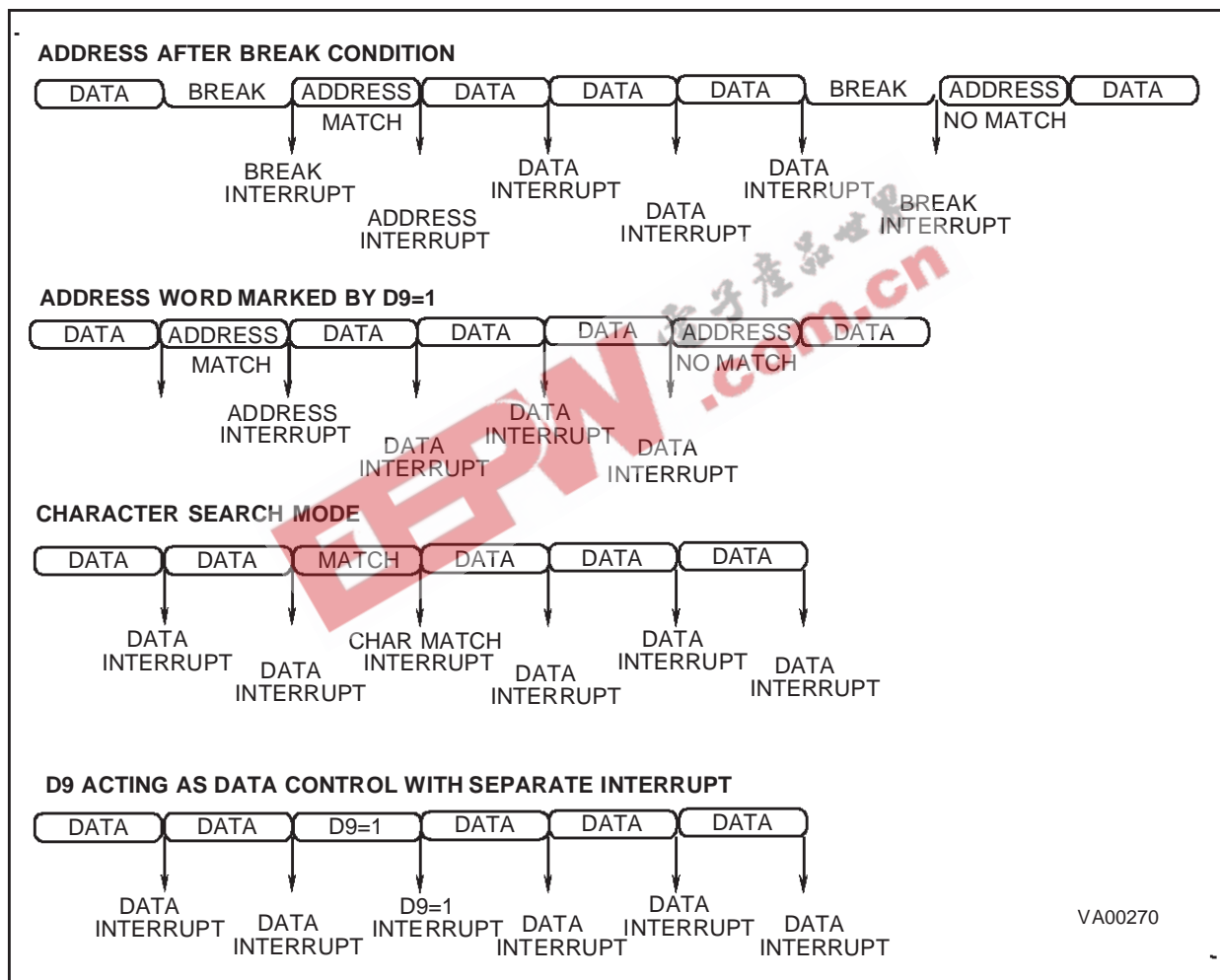

SERIAL COMMUNICATIONS INTERFACE (Cont'd)**8.4.9.2 DMA**

Two DMA channels are associated with the SCI, for transmit and for receive. These follow the register scheme as described in the DMA chapter.

DMA Reception

To perform a DMA transfer in reception mode:

1. Initialize the DMA counter (RDCPR) and DMA address (RDAPR) registers
2. Enable DMA by setting the RXD bit in the IDPR register.
3. DMA transfer is started when data is received by the SCI.

DMA Transmission

To perform a DMA transfer in transmission mode:

1. Initialize the DMA counter (TDCPR) and DMA address (TDAPR) registers.
2. Enable DMA by setting the TXD bit in the IDPR register.
3. DMA transfer is started by writing a byte in the Transmitter Buffer register (TXBR).

If this byte is the first data byte to be transmitted, the DMA counter and address registers must be initialized to begin DMA transmission at the second byte. Alternatively, DMA transfer can be started by writing a dummy byte in the TXBR register.

DMA Interrupts

When DMA is active, the Received Data Pending and the Transmitter Shift Register Empty interrupt sources are replaced by the DMA End Of Block receive and transmit interrupt sources.

Note: To handle DMA transfer correctly in transmission, the BSN bit in the IMR register must be cleared. This selects the Transmitter Shift Register Empty event as the DMA interrupt source.

The transfer of the last byte of a DMA data block will be followed by a DMA End Of Block transmit or receive interrupt, setting the TXEOB or RXEOB bit.

A typical Transmission End Of Block interrupt routine will perform the following actions:

1. Restore the DMA counter register (TDCPR).
2. Restore the DMA address register (TDAPR).
3. Clear the Transmitter Shift Register Empty bit TXSEM in the S_ISR register to avoid spurious interrupts.
4. Clear the Transmitter End Of Block (TXEOB) pending bit in the IMR register.
5. Set the TXD bit in the IDPR register to enable DMA.
6. Load the Transmitter Buffer Register (TXBR) with the next byte to transmit.

The above procedure handles the case where a further DMA transfer is to be performed.

Error Interrupt Handling

If an error interrupt occurs while DMA is enabled in reception mode, DMA transfer is stopped.

To resume DMA transfer, the error interrupt handling routine must clear the corresponding error flag. In the case of an Overrun error, the routine must also read the RXBR register.

Character Search Mode with DMA

In Character Search Mode with DMA, when a character match occurs, this character is not transferred. DMA continues with the next received character. To avoid an Overrun error occurring, the Character Match interrupt service routine must read the RXBR register.

ST92163 - SERIAL COMMUNICATIONS INTERFACE (SCI)

SERIAL COMMUNICATIONS INTERFACE (Cont'd)

8.4.10 Register Description

The SCI registers are located in the following pages in the ST9:

SCI number 0: page 24 (18h)

SCI number 1: page 25 (19h) (when present)

The SCI is controlled by the following registers:

Address	Register
R240 (F0h)	Receiver DMA Transaction Counter Pointer Register
R241 (F1h)	Receiver DMA Source Address Pointer Register
R242 (F2h)	Transmitter DMA Transaction Counter Pointer Register
R243 (F3h)	Transmitter DMA Destination Address Pointer Register
R244 (F4h)	Interrupt Vector Register
R245 (F5h)	Address Compare Register
R246 (F6h)	Interrupt Mask Register
R247 (F7h)	Interrupt Status Register
R248 (F8h)	Receive Buffer Register same Address as Transmitter Buffer Register (Read Only)
R248 (F8h)	Transmitter Buffer Register same Address as Receive Buffer Register (Write only)
R249 (F9h)	Interrupt/DMA Priority Register
R250 (FAh)	Character Configuration Register
R251 (FBh)	Clock Configuration Register
R252 (FCh)	Baud Rate Generator High Register
R253 (FDh)	Baud Rate Generator Low Register
R254 (FEh)	Synchronous Input Control Register
R255 (FFh)	Synchronous Output Control Register

SERIAL COMMUNICATIONS INTERFACE (Cont'd)

RECEIVER DMA COUNTER POINTER (RDCPR)

R240 - Read/Write

Reset value: undefined

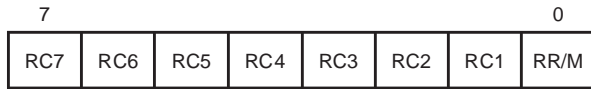

Bit 7:1 = **RC[7:1]**: *Receiver DMA Counter Pointer*. These bits contain the address of the receiver DMA transaction counter in the Register File.

Bit 0 = **RR/M**: *Receiver Register File/Memory Selector*.

- 0: Select Memory space as destination.
- 1: Select the Register File as destination.

RECEIVER DMA ADDRESS POINTER (RDAPR)

R241 - Read/Write

Reset value: undefined

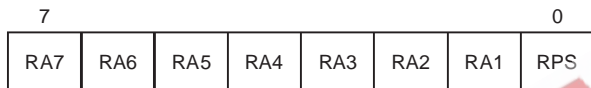

Bit 7:1 = **RA[7:1]**: *Receiver DMA Address Pointer*. These bits contain the address of the pointer (in the Register File) of the receiver DMA data source.

Bit 0 = **RPS**: *Receiver DMA Memory Pointer Selector*.

- This bit is only significant if memory has been selected for DMA transfers (RR/M = 0 in the RDCPR register).
- 0: Select ISR register for receiver DMA transfers address extension.
- 1: Select DMASR register for receiver DMA transfers address extension.

TRANSMITTER DMA COUNTER POINTER (TDCPR)

R242 - Read/Write

Reset value: undefined

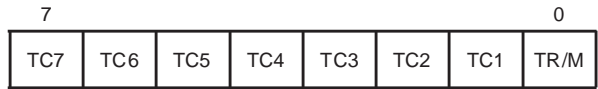

Bit 7:1 = **TC[7:1]**: *Transmitter DMA Counter Pointer*.

These bits contain the address of the transmitter DMA transaction counter in the Register File.

Bit 0 = **TR/M**: *Transmitter Register File/Memory Selector*.

- 0: Select Memory space as source.
- 1: Select the Register File as source.

TRANSMITTER DMA ADDRESS POINTER (TDAPR)

R243 - Read/Write

Reset value: undefined

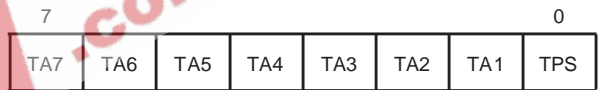

Bit 7:1 = **TA[7:1]**: *Transmitter DMA Address Pointer*.

These bits contain the address of the pointer (in the Register File) of the transmitter DMA data source.

Bit 0 = **TPS**: *Transmitter DMA Memory Pointer Selector*.

- This bit is only significant if memory has been selected for DMA transfers (TR/M = 0 in the TDCPR register).
- 0: Select ISR register for transmitter DMA transfers address extension.
- 1: Select DMASR register for transmitter DMA transfers address extension.

ST92163 - SERIAL COMMUNICATIONS INTERFACE (SCI)

SERIAL COMMUNICATIONS INTERFACE (Cont'd)

INTERRUPT VECTOR REGISTER (S_IVR)

R244 - Read/Write

Reset value: undefined

7							0
V7	V6	V5	V4	V3	EV2	EV1	0

Bit 7:3 = **V[7:3]**: *SCI Interrupt Vector Base Address*.

User programmable interrupt vector bits for transmitter and receiver.

Bit 2:1 = **EV[2:1]**: *Encoded Interrupt Source*.

Both bits EV2 and EV1 are read only and set by hardware according to the interrupt source.

EV2	EV1	Interrupt source
0	0	Receiver Error (Overrun, Framing, Parity)
0	1	Break Detect or Address Match
1	0	Received Data Pending/Receiver DMA End of Block
1	1	Transmitter buffer or shift register empty transmitter DMA End of Block

Bit 0 = **D0**: This bit is forced by hardware to 0.

ADDRESS/DATA COMPARE REGISTER (ACR)

R245 - Read/Write

Reset value: undefined

7							0
AC7	AC6	AC5	AC4	AC3	AC2	AC1	AC0

Bit 7:0 = **AC[7:0]**: *Address/Compare Character*. With either 9th bit address mode, address after break mode, or character search, the received address will be compared to the value stored in this register. When a valid address matches this register content, the Receiver Address Pending bit (RXAP in the S_ISR register) is set. After the RXAP bit is set in an addressed mode, all received data words will be transferred to the Receiver Buffer Register.

SERIAL COMMUNICATIONS INTERFACE (Cont'd)

INTERRUPT MASK REGISTER (IMR)

R246 - Read/Write

Reset value: 0xx00000

7	0						
BSN	RXEOB	TXEOB	RXE	RXA	RXB	RXDI	TXDI

Bit 7 = **BSN**: *Buffer or shift register empty interrupt.*

This bit selects the source of the transmitter register empty interrupt.

0: Select a Shift Register Empty as source of a Transmitter Register Empty interrupt.

1: Select a Buffer Register Empty as source of a Transmitter Register Empty interrupt.

Bit 6 = **RXEOB**: *Received End of Block.*

This bit is set by hardware only and must be reset by software. RXEOB is set after a receiver DMA cycle to mark the end of a data block.

0: Clear the interrupt request.

1: Mark the end of a received block of data.

Bit 5 = **TXEOB**: *Transmitter End of Block.*

This bit is set by hardware only and must be reset by software. TXEOB is set after a transmitter DMA cycle to mark the end of a data block.

0: Clear the interrupt request.

1: Mark the end of a transmitted block of data.

Bit 4 = **RXE**: *Receiver Error Mask.*

0: Disable Receiver error interrupts (OE, PE, and FE pending bits in the S_ISR register).

1: Enable Receiver error interrupts.

Bit 3 = **RXA**: *Receiver Address Mask.*

0: Disable Receiver Address interrupt (RXAP pending bit in the S_ISR register).

1: Enable Receiver Address interrupt.

Bit 2 = **RXB**: *Receiver Break Mask.*

0: Disable Receiver Break interrupt (RXBP pending bit in the S_ISR register).

1: Enable Receiver Break interrupt.

Bit 1 = **RXDI**: *Receiver Data Interrupt Mask.*

0: Disable Receiver Data Pending and Receiver End of Block interrupts (RXDP and RXEOB pending bits in the S_ISR register).

1: Enable Receiver Data Pending and Receiver End of Block interrupts.

Note: RXDI has no effect on DMA transfers.

Bit 0 = **TXDI**: *Transmitter Data Interrupt Mask.*

0: Disable Transmitter Buffer Register Empty, Transmitter Shift Register Empty, or Transmitter End of Block interrupts (TXBEM, TXSEM, and TXEOB bits in the S_ISR register).

1: Enable Transmitter Buffer Register Empty, Transmitter Shift Register Empty, or Transmitter End of Block interrupts.

Note: TXDI has no effect on DMA transfers.

SERIAL COMMUNICATIONS INTERFACE (Cont'd)

INTERRUPT STATUS REGISTER (S_ISR)

R247 - Read/Write

Reset value: undefined

7	0						
OE	FE	PE	RXAP	RXBP	RXDP	TXBEM	TXSEM

Bit 7 = OE: Overrun Error Pending.
 This bit is set by hardware if the data in the Receiver Buffer Register was not read by the CPU before the next character was transferred into the Receiver Buffer Register (the previous data is lost).
 0: No Overrun Error.
 1: Overrun Error occurred.

Bit 6 = FE: Framing Error Pending bit.
 This bit is set by hardware if the received data word did not have a valid stop bit.
 0: No Framing Error.
 1: Framing Error occurred.

Note: In the case where a framing error occurs when the SCI is programmed in address mode and is monitoring an address, the interrupt is asserted and the corrupted data element is transferred to the Receiver Buffer Register.

Bit 5 = PE: Parity Error Pending.
 This bit is set by hardware if the received word did not have the correct even or odd parity bit.
 0: No Parity Error.
 1: Parity Error occurred.

Bit 4 = RXAP: Receiver Address Pending.
 RXAP is set by hardware after an interrupt acknowledged in the address mode.
 0: No interrupt in address mode.
 1: Interrupt in address mode occurred.

Note: The source of this interrupt is given by the couple of bits (AMEN, AM) as detailed in the IDPR register description.

Bit 3 = RXBP: Receiver Break Pending bit.
 This bit is set by hardware if the received data input is held low for the full word transmission time (start bit, data bits, parity bit, stop bit).
 0: No break received.
 1: Break event occurred.

Bit 2 = RXDP: Receiver Data Pending bit.
 This bit is set by hardware when data is loaded into the Receiver Buffer Register.
 0: No data received.
 1: Data received in Receiver Buffer Register.

Bit 1 = TXBEM: Transmitter Buffer Register Empty.
 This bit is set by hardware if the Buffer Register is empty.
 0: No Buffer Register Empty event.
 1: Buffer Register Empty.

Bit 0 = TXSEM: Transmitter Shift Register Empty.
 This bit is set by hardware if the Shift Register has completed the transmission of the available data.
 0: No Shift Register Empty event.
 1: Shift Register Empty.

Note: The Interrupt Status Register bits can be reset but cannot be set by the user. The interrupt source must be cleared by resetting the related bit when executing the interrupt service routine (naturally the other pending bits should not be reset).

SERIAL COMMUNICATIONS INTERFACE (Cont'd)

RECEIVER BUFFER REGISTER (RXBR)

R248 - Read only
Reset value: undefined

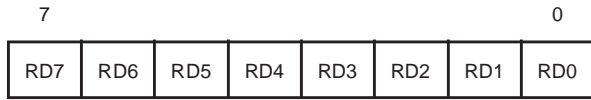

Bit 7:0 = **RD[7:0]**: *Received Data*.
This register stores the data portion of the received word. The data will be transferred from the Receiver Shift Register into the Receiver Buffer Register at the end of the word. All receiver interrupt conditions will be updated at the time of transfer. If the selected character format is less than 8 bits, unused most significant bits will forced to "1".

Note: RXBR and TXBR are two physically different registers located at the same address.

TRANSMITTER BUFFER REGISTER (TXBR)

R248 - Write only
Reset value: undefined

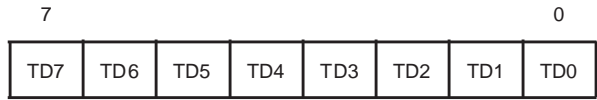

Bit 7:0 = **TD[7:0]**: *Transmit Data*.
The ST9 core will load the data for transmission into this register. The SCI will transfer the data from the buffer into the Shift Register when available. At the transfer, the Transmitter Buffer Register interrupt is updated. If the selected word format is less than 8 bits, the unused most significant bits are not significant.

Note: TXBR and RXBR are two physically different registers located at the same address.



ST92163 - SERIAL COMMUNICATIONS INTERFACE (SCI)

SERIAL COMMUNICATIONS INTERFACE (Cont'd)

INTERRUPT/DMA PRIORITY REGISTER (IDPR)

R249 - Read/Write

Reset value: undefined

7							0
AMEN	SB	SA	RXD	TXD	PRL2	PRL1	PRL0

Bit 7 = **AMEN**: *Address Mode Enable*.

This bit, together with the AM bit (in the CHCR register), decodes the desired addressing/9th data bit/character match operation.

In Address mode the SCI monitors the input serial data until its address is detected

AMEN	AM	
0	0	Address interrupt if 9th data bit = 1
0	1	Address interrupt if character match
1	0	Address interrupt if character match and 9th data bit =1
1	1	Address interrupt if character match with word immediately following Break

Note: Upon reception of address, the RXAP bit (in the Interrupt Status Register) is set and an interrupt cycle can begin. The address character will not be transferred into the Receiver Buffer Register but all data following the matched SCI address and preceding the next address word will be transferred to the Receiver Buffer Register and the proper interrupts updated. If the address does not match, all data following this unmatched address will not be transferred to the Receiver Buffer Register.

In any of the cases the RXAP bit must be reset by software before the next word is transferred into the Buffer Register.

When AMEN is reset and AM is set, a useful character search function is performed. This allows the SCI to generate an interrupt whenever a specific character is encountered (e.g. Carriage Return).

Bit 6 = **SB**: *Set Break*.

0: Stop the break transmission after minimum break length.

1: Transmit a break following the transmission of all data in the Transmitter Shift Register and the Buffer Register.

Note: The break will be a low level on the transmitter data output for at least one complete word for-

mat. If software does not reset SB before the minimum break length has finished, the break condition will continue until software resets SB. The SCI terminates the break condition with a high level on the transmitter data output for one transmission clock period.

Bit 5 = **SA**: *Set Address*.

If an address/9th data bit mode is selected, SA value will be loaded for transmission into the Shift Register. This bit is cleared by hardware after its load.

0: Indicate it is not an address word.

1: Indicate an address word.

Note: Proper procedure would be, when the Transmitter Buffer Register is empty, to load the value of SA and then load the data into the Transmitter Buffer Register.

Bit 4 = **RXD**: *Receiver DMA Mask*.

This bit is reset by hardware when the transaction counter value decrements to zero. At that time a receiver End of Block interrupt can occur.

0: Disable Receiver DMA request (the RXDP bit in the S_ISR register can request an interrupt).

1: Enable Receiver DMA request (the RXDP bit in the S_ISR register can request a DMA transfer).

Bit 3 = **TXD**: *Transmitter DMA Mask*.

This bit is reset by hardware when the transaction counter value decrements to zero. At that time a transmitter End Of Block interrupt can occur.

0: Disable Transmitter DMA request (TXBEM or TXSEM bits in S_ISR can request an interrupt).

1: Enable Transmitter DMA request (TXBEM or TXSEM bits in S_ISR can request a DMA transfer).

Bit 2:0 = **PRL[2:0]**: *SCI Interrupt/DMA Priority bits*.

The priority for the SCI is encoded with (PRL2,PRL1,PRL0). Priority level 0 is the highest, while level 7 represents no priority.

When the user has defined a priority level for the SCI, priorities within the SCI are hardware defined. These SCI internal priorities are:

Receiver DMA request	highest priority
Transmitter DMA request	
Receiver interrupt	
Transmitter interrupt	lowest priority

SERIAL COMMUNICATIONS INTERFACE (Cont'd)

CHARACTER CONFIGURATION REGISTER (CHCR)

R250 - Read/Write

Reset value: undefined

7							0
AM	EP	PEN	AB	SB1	SB0	WL1	WL0

Bit 7 = **AM**: Address Mode.

This bit, together with the AMEN bit (in the IDPR register), decodes the desired addressing/9th data bit/character match operation. Please refer to the table in the IDPR register description.

Bit 6 = **EP**: Even Parity.

0: Select odd parity (when parity is enabled).
1: Select even parity (when parity is enabled).

Bit 5 = **PEN**: Parity Enable.

0: No parity bit.
1: Parity bit generated (transmit data) or checked (received data).

Note: If the address/9th bit is enabled, the parity bit will precede the address/9th bit (the 9th bit is never included in the parity calculation).

Bit 4 = **AB**: Address/9th Bit.

0: No Address/9th bit.
1: Address/9th bit included in the character format between the parity bit and the first stop bit. This bit can be used to address the SCI or as a ninth data bit.

Bit 3:2 = **SB[1:0]**: Number of Stop Bits..

SB1	SB0	Number of stop bits	
		in 16X mode	in 1X mode
0	0	1	1
0	1	1.5	2
1	0	2	2
1	1	2.5	3

Bit 1:0 = **WL[1:0]**: Number of Data Bits

WL1	WL0	Data Length
0	0	5 bits
0	1	6 bits
1	0	7 bits
1	1	8 bits

ST92163 - SERIAL COMMUNICATIONS INTERFACE (SCI)

SERIAL COMMUNICATIONS INTERFACE (Cont'd)

CLOCK CONFIGURATION REGISTER (CCR)

R251 - Read/Write

Reset value: 0000 0000 (00h)

7							0
XTCLK	OCLK	XRX	XBRG	CD	AEN	LBEN	STPEN

Bit 7 = XTCLK

This bit, together with the OCLK bit, selects the source for the transmitter clock. The following table shows the coding of XTCLK and OCLK.

Bit 6 = OCLK

This bit, together with the XTCLK bit, selects the source for the transmitter clock. The following table shows the coding of XTCLK and OCLK.

XTCLK	OCLK	Pin Function
0	0	Pin is used as a general I/O
0	1	Pin = TXCLK (used as an input)
1	0	Pin = CLKOUT (outputs the Baud Rate Generator clock)
1	1	Pin = CLKOUT (outputs the Serial expansion and synchronous mode clock)

Bit 5 = XRX: External Receiver Clock Source.

0: External receiver clock source not used.
1: Select the external receiver clock source.

Note: The external receiver clock frequency must be 16 times the data rate, or equal to the data rate, depending on the status of the CD bit.

Bit 4 = XBRG: Baud Rate Generator Clock Source.

0: Select INTCLK for the baud rate generator.
1: Select the external receiver clock for the baud rate generator.

Bit 3 = CD: Clock Divisor.

The status of CD will determine the SCI configuration (synchronous/asynchronous).

0: Select 16X clock mode for both receiver and transmitter.

1: Select 1X clock mode for both receiver and transmitter.

Note: In 1X clock mode, the transmitter will transmit data at one data bit per clock period. In 16X mode each data bit period will be 16 clock periods long.

Bit 2 = AEN: Auto Echo Enable.

0: No auto echo mode.

1: Put the SCI in auto echo mode.

Note: Auto Echo mode has the following effect: the SCI transmitter is disconnected from the data-out pin SOUT, which is driven directly by the receiver data-in pin, SIN. The receiver remains connected to SIN and is operational, unless loopback mode is also selected.

Bit 1 = LBEN: Loopback Enable.

0: No loopback mode.

1: Put the SCI in loopback mode.

Note: In this mode, the transmitter output is set to a high level, the receiver input is disconnected, and the output of the Transmitter Shift Register is looped back into the Receiver Shift Register input. All interrupt sources (transmitter and receiver) are operational.

Bit 0 = STPEN: Stick Parity Enable.

0: The transmitter and the receiver will follow the parity of even parity bit EP in the CHCR register.

1: The transmitter and the receiver will use the opposite parity type selected by the even parity bit EP in the CHCR register.

EP	SPEN	Parity (Transmitter & Receiver)
0 (odd)	0	Odd
1 (even)	0	Even
0 (odd)	1	Even
1 (even)	1	Odd

SERIAL COMMUNICATIONS INTERFACE (Cont'd)

BAUD RATE GENERATOR HIGH REGISTER (BRGHR)

R252 - Read/Write

Reset value: undefined

15	8						
BG15	BG14	BG13	BG12	BG11	BG10	BG9	BG8

BAUD RATE GENERATOR LOW REGISTER (BRGLR)

R253 - Read/Write

Reset value: undefined

7	0						
BG7	BG6	BG5	BG4	BG3	BG2	BG1	BG0

Bit 15:0 = *Baud Rate Generator MSB and LSB.*

The Baud Rate generator is a programmable divide by "N" counter which can be used to generate the clocks for the transmitter and/or receiver. This counter divides the clock input by the value in the Baud Rate Generator Register. The minimum baud rate divisor is 2 and the maximum divisor is $2^{16}-1$. After initialization of the baud rate generator, the divisor value is immediately loaded into the counter. This prevents potentially long random counts on the initial load. If set to 0 or 1, the Baud Rate Generator is stopped.

SYNCHRONOUS INPUT CONTROL (SICR)

R254 - Read/Write

Reset value: 0000 0011 (03h)

7	0						
SMEN	INPL	XCKPL	DCDEN	DCDPL	INPEN	X	X

Bit 7 = **SMEN**: *Synchronous Mode Enable.*

0: Disable all features relating to Synchronous mode (the contents of SICR and SOCR are ignored).

1: Select Synchronous mode with its programmed I/O configuration.

Bit 6 = **INPL**: *SIN Input Polarity.*

0: Polarity not inverted.

1: Polarity inverted.

Note: INPL only affects received data. In Auto-Echo mode SOUT = SIN even if INPL is set. In Loop-Back mode the state of the INPL bit is irrelevant.

Bit 5 = **XCKPL**: *Receiver Clock Polarity.*

0: RXCLK is active on the rising edge.

1: RXCLK is active on the falling edge.

Note: XCKPL only affects the receiver clock. In Auto-Echo mode CLKOUT = RXCLK independently of the XCKPL status. In Loop-Back the state of the XCKPL bit is irrelevant.

Bit 4 = **DCDEN**: *DCD Input Enable.*

0: Disable hardware synchronization.

1: Enable hardware synchronization.

Note: When DCDEN is set, RXCLK drives the receiver section only during the active level of the DCD input (DCD works as a gate on RXCLK, informing the MCU that a transmitting device is sending a synchronous frame to it).

Bit 3 = **DCDPL**: *DCD Input Polarity.*

0: The DCD input is active when LOW.

1: The DCD input is active when HIGH.

Note: DCDPL only affects the gating activity of the receiver clock. In Auto-Echo mode RTS = DCD independently of DCDPL. In Loop-Back mode, the state of DCDPL is irrelevant.

Bit 2 = **INPEN**: *All Input Disable.*

0: Enable SIN/RXCLK/DCD inputs.

1: Disable SIN/RXCLK/DCD inputs.

Bit 1:0 = "Don't Care"

ST92163 - SERIAL COMMUNICATIONS INTERFACE (SCI)

SERIAL COMMUNICATIONS INTERFACE (Cont'd)

SYNCHRONOUS OUTPUT CONTROL (SOCR)

R255 - Read/Write

Reset value: 0000 0001 (01h)

7							0
OUTP L	OUTS B	OCKP L	OCKS B	RTSE N	RTS PL	OUT DIS	X

Bit 7 = **OUTPL**: *SOUT Output Polarity.*

0: Polarity not inverted.

1: Polarity inverted.

Note: OUTPL only affects the data sent by the transmitter section. In Auto-Echo mode SOUT = SIN even if OUTPL=1. In Loop-Back mode, the state of OUTPL is irrelevant.

Bit 6 = **OUTSB**: *SOUT Output Stand-By Level.*

0: SOUT stand-by level is HIGH.

1: SOUT stand-by level is LOW.

Bit 5 = **OCKPL**: *Transmitter Clock Polarity.*

0: CLKOUT is active on the rising edge.

1: CLKOUT is active on the falling edge.

Note: OCKPL only affects the transmitter clock. In Auto-Echo mode CLKOUT = RXCLK independently of the state of OCKPL. In Loop-Back mode the state of OCKPL is irrelevant.

Bit 4 = **OCKSB**: *Transmitter Clock Stand-By Level.*

0: The CLKOUT stand-by level is HIGH.

1: The CLKOUT stand-by level is LOW.

Bit 3 = **RTSEN**: *RTS and SDS Output Enable.*

0: Disable the RTS and SDS hardware synchronization.

1: Enable the RTS and SDS hardware synchronization.

Notes:

– When RTSEN is set, the RTS output becomes active just before the first active edge of CLK-OUT and indicates to target device that the MCU is about to send a synchronous frame; it returns to its stand-by value just after the last active edge of CLKOUT (MSB transmitted).

– When RTSEN is set, the SDS output becomes active high and indicates to the target device that the MCU is about to send the first bit of a synchronous frame on the Serial Output Pin (SOUT); it returns to low level as soon as the second bit is sent on the Serial Output Pin (SOUT). In this way a positive pulse is generated each time that the first bit of a synchronous frame is present on the Serial Output Pin (SOUT).

Bit 2 = **RTSPL**: *RTS Output Polarity.*

0: The RTS output is active when LOW.

1: The RTS output is active when HIGH.

Note: RTSPL only affects the RTS activity on the output pin. In Auto-Echo mode RTS = DCD independently from the RTSPL value. In Loop-Back mode RTSPL value is 'Don't Care'.

Bit 1 = **OUTDIS**: *Disable all outputs.*

This feature is available on specific devices only (see device pin-out description).

When OUTDIS=1, all output pins (if configured in Alternate Function mode) will be put in High Impedance for networking.

0: SOUT/CLKOUT/enabled

1: SOUT/CLKOUT/RTS put in high impedance

Bit 0 = "Don't Care"

8.5 I²C BUS INTERFACE

8.5.1 Introduction

The I²C bus Interface serves as an interface between the microcontroller and the serial I²C bus. It provides both multimaster and slave functions with both 7-bit and 10-bit address modes; it controls all I²C bus-specific sequencing, protocol, arbitration, timing and supports both standard (100KHz) and fast I²C modes (400KHz).

Using DMA, data can be transferred with minimum use of CPU time.

The peripheral uses two external lines to perform the protocols: SDA, SCL.

8.5.2 Main Features

- Parallel-bus/I²C protocol converter
- Multi-master capability
- 7-bit/10-bit Addressing
- Standard I²C mode/Fast I²C mode
- Transmitter/Receiver flag
- End-of-byte transmission flag
- Transfer problem detection
- Interrupt generation on error conditions
- Interrupt generation on transfer request and on data received

I²C Master Features:

- Start bit detection flag
- Clock generation
- I²C bus busy flag
- Arbitration Lost flag
- End of byte transmission flag
- Transmitter/Receiver flag
- Stop/Start generation

I²C Slave Features:

- Stop bit detection
- I²C bus busy flag
- Detection of misplaced start or stop condition
- Programmable I²C Address detection (both 7-bit and 10-bit mode)
- General Call address programmable
- Transfer problem detection
- End of byte transmission flag
- Transmitter/Receiver flag.

Interrupt Features:

- Interrupt generation on error condition, on transmission request and on data received
- Interrupt address vector for each interrupt source
- Pending bit and mask bit for each interrupt source
- Programmable interrupt priority respects the other peripherals of the microcontroller
- Interrupt address vector programmable

DMA Features:

- DMA both in transmission and in reception with enabling bits
- DMA from/toward both Register File and Memory
- End Of Block interrupt sources with the related pending bits
- Selection between DMA Suspended and DMA Not-Suspended mode if error condition occurs.

I²C INTERFACE (Cont'd)

Figure 82. I²C Interface Block Diagram

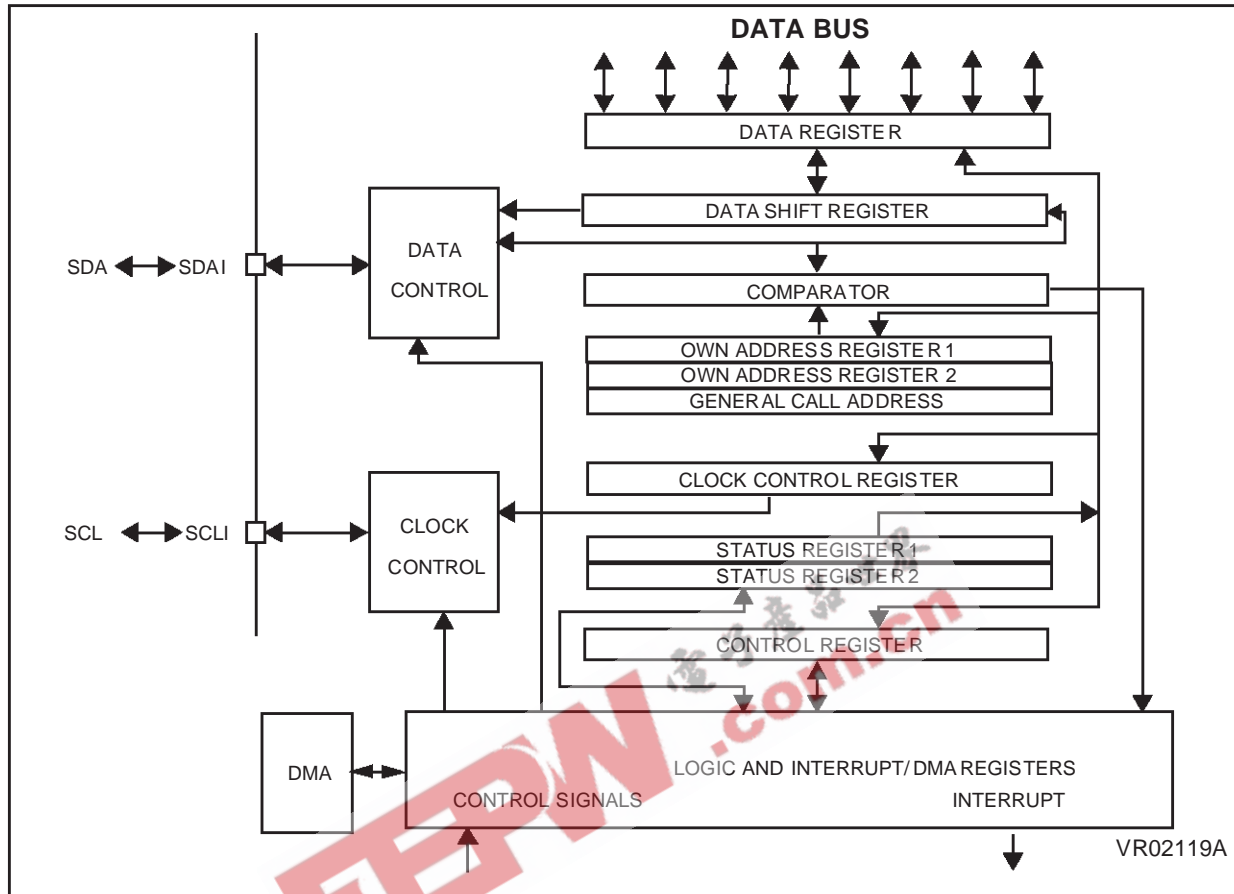

8.5.3 Functional Description

Refer to the I2CCR, I2CSR1 and I2CSR2 registers in Section 8.5.7. for the bit definitions.

The I²C interface works as an I/O interface between the ST9 microcontroller and the I²C bus protocol. In addition to receiving and transmitting data, the interface converts data from serial to parallel format and vice versa using an interrupt or polled handshake.

It operates in Multimaster/slave I²C mode. The selection of the operating mode is made by software.

The I²C interface is connected to the I²C bus by a data pin (SDAI) and a clock pin (SCLI) which must be configured as open drain when the I²C cell is enabled by programming the I/O port bits and the PE bit in the I2CCR register. In this case, the value of the external pull-up resistance used depends on the application.

When the I²C cell is disabled, the SDAI and SCLI ports revert to being standard I/O port pins.

The I²C interface has sixteen internal registers.

Six of them are used for initialization:

- Own Address Registers I2COAR1, I2COAR2
- General Call Address Register I2CADR
- Clock Control Registers I2CCCR, I2CECCR
- Control register I2CCR

The following four registers are used during data transmission/reception:

- Data Register I2CDR
- Control Register I2CCR
- Status Register 1 I2CSR1
- Status Register 2 I2CSR2

I²C INTERFACE (Cont'd)

The following seven registers are used to handle the interrupt and the DMA features:

- Interrupt Status Register I2CISR
- Interrupt Mask Register I2CIMR
- Interrupt Vector Register I2CIVR
- Receiver DMA Address Pointer Register I2CRDAP
- Receiver DMA Transaction Counter Register I2CRDC
- Transmitter DMA Address Pointer Register I2CTDAP
- Transmitter DMA transaction Counter Register I2CTDC

The interface can decode both addresses:

- Software programmable 7-bit General Call address
- I²C address stored by software in the I2COAR1 register in 7-bit address mode or stored in I2COAR1 and I2COAR2 registers in 10-bit address mode.

After a reset, the interface is disabled.

IMPORTANT:

1. To guarantee correct operation, before enabling the peripheral (while I2CCR.PE=0), configure bit7 and bit6 of the I2COAR2 register according to the internal clock INTCLK (for example 11xxxxxb in the range 14 - 30 MHz).
2. Bit7 of the I2CCR register must be cleared.

8.5.3.1 Mode Selection

In I²C mode, the interface can operate in the four following modes:

- Master transmitter/receiver
- Slave transmitter/receiver

By default, it operates in slave mode.

This interface automatically switches from slave to master after a start condition is generated on the bus and from master to slave in case of arbitration loss or stop condition generation.

In Master mode, it initiates a data transfer and generates the clock signal. A serial data transfer always begins with a start condition and ends with a stop condition. Both start and stop conditions are generated in master mode by software.

In Slave mode, it is able to recognize its own address (7 or 10-bit), as stored in the I2COAR1 and I2COAR2 registers and (when the I2CCR.ENG

bit is set) the General Call address (stored in I2CADR register). It never recognizes the Start Byte (address byte 01h) whatever its own address is.

Data and addresses are transferred in 8 bits, MSB first. The first byte(s) following the start condition contain the address (one byte in 7-bit mode, two bytes in 10-bit mode). The address is always transmitted in master mode.

A 9th clock pulse follows the 8 clock cycles of a byte transfer, during which the receiver must send an acknowledge bit to the transmitter. Acknowledge is enabled and disabled by software. Refer to Figure 83.

I2C INTERFACE (Cont'd)

Figure 83. I²C BUS Protocol

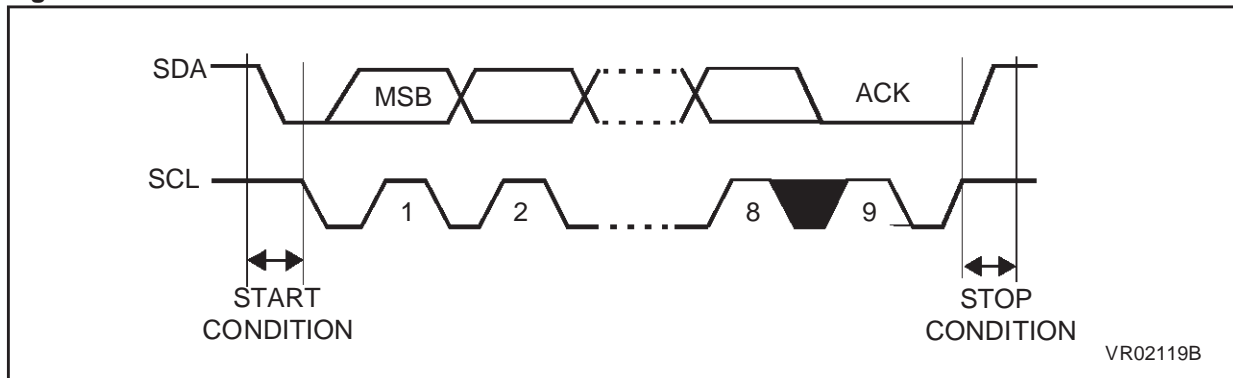

Any transfer can be done using either the I²C registers directly or via the DMA.

If the transfer is to be done directly on I²C, the interface waits (by holding the SCL line low) for software to write in the Data Register before transmission of a data byte, or to read the Data Register after a data byte is received.

If the transfer is to be done via DMA, the interface sends a request for a DMA transfer. Then it waits for the DMA to complete. The transfer between the interface and the I²C bus will begin on the next rising edge of the SCL clock.

The SCL frequency (F_{scl}) generated in master mode is controlled by a programmable clock divider. The speed of the I²C interface may be selected between Standard (0-100KHz) and Fast (100-400KHz) I²C modes.

8.5.4 I²C State Machine

To enable the interface in I²C mode the I2CCR.PE bit must be set **twice** as the first write only activates the interface (only the PE bit is set); and the bit7 of I2CCR register must be cleared.

The I²C interface always operates in slave mode (the M/SL bit is cleared) except when it initiates a transmission or a receipt sequencing (master mode).

The multimaster function is enabled with an automatic switch from master mode to slave mode when the interface loses the arbitration of the I²C bus.

8.5.4.1 I²C Slave Mode

As soon as a start condition is detected, the address word is received from the SDA line and sent to the shift register; then it is compared with the address of the interface or the General Call address (if selected by software).

Note: In 10-bit addressing mode, the comparison includes the header sequence (11110xx0) and the two most significant bits of the address.

- **Header (10-bit mode) or Address (both 10-bit and 7-bit modes) not matched:** the state machine is reset and waits for another Start condition.
- **Header matched (10-bit mode only):** the interface generates an acknowledge pulse if the ACK bit of the control register (I2CCR) is set.
- **Address matched:** the I2CSR1.ADSL bit is set and an acknowledge bit is sent to the master if the I2CCR.ACK bit is set. An interrupt is sent to the microcontroller if the I2CCR.ITE bit is set. Then it waits for the microcontroller to read the I2CSR1 register **by holding the SCL line low** (see Figure 84 Transfer sequencing EV1).

I²C INTERFACE (Cont'd)

Next, depending on the data direction bit (least significant bit of the address byte), and after the generation of an acknowledge, the slave must go in sending or receiving mode.

In 10-bit mode, after receiving the address sequence the slave is always in receive mode. It will enter transmit mode on receiving a repeated Start condition followed by the header sequence with matching address bits and the least significant bit set (11110xx1).

Slave Receiver

Following the address reception and after I2CSR1 register has been read, the slave receives bytes from the SDA line into the Shift Register and sends them to the I2CDR register. After each byte it generates an acknowledge bit if the I2CCR.ACK bit is set.

When the acknowledge bit is sent, the I2CSR1.BTF flag is set and an interrupt is generated if the I2CCR.ITE bit is set (see Figure 84 Transfer sequencing EV2).

Then the interface waits for a read of the I2CSR1 register followed by a read of the I2CDR register, or waits for the DMA to complete; **both holding the SCL line low**.

Slave Transmitter

Following the address reception and after I2CSR1 register has been read, the slave sends bytes from the I2CDR register to the SDA line via the internal shift register.

When the acknowledge bit is received, the I2CCR.BTF flag is set and an interrupt is generated if the I2CCR.ITE bit is set (see Figure 84 Transfer sequencing EV3).

The slave waits for a read of the I2CSR1 register followed by a write in the I2CDR register or waits for the DMA to complete, **both holding the SCL line low**.

Error Cases

- **BERR**: Detection of a Stop or a Start condition during a byte transfer.
The I2CSR2.BERR flag is set and an interrupt is generated if I2CCR.ITE bit is set.
If it is a stop then the state machine is reset.
If it is a start then the state machine is reset and it waits for the new slave address on the bus.

- **AF**: Detection of a no-acknowledge bit.
The I2CSR2.AF flag is set and an interrupt is generated if the I2CCR.ITE bit is set.

Note: In both cases, SCL line is not stretched low; however, the SDA line, due to possible «0» bits transmitted last, can remain low. It is then necessary to release both lines by software.

Other Events

- **ADSL**: Detection of a Start condition after an acknowledge time-slot.
The state machine is reset and starts a new process. The I2CSR1.ADSL flag bit is set and an interrupt is generated if the I2CCR.ITE bit is set.
The SCL line is stretched low.
- **STOPF**: Detection of a Stop condition after an acknowledge time-slot.
The state machine is reset. Then the I2CSR2.STOPF flag is set and an interrupt is generated if the I2CCR.ITE bit is set.

How to release the SDA / SCL lines

Set and subsequently clear the I2CCR.STOP bit while the I2CSR1.BTF bit is set; then the SDA/SCL lines are released immediately after the transfer of the current byte.

This will also reset the state machine; any subsequent STOP bit (EV4) will **not** be detected.

8.5.4.2 I²C Master Mode

To switch from default Slave mode to Master mode a Start condition generation is needed.

Setting the I2CCR.START bit while the I2CSR1.BUSY bit is cleared causes the interface to generate a Start condition.

Once the Start condition is generated, the peripheral is in master mode (I2CSR1.M/SL=1) and I2CSR1.SB (Start bit) flag is set and an interrupt is generated if the I2CCR.ITE bit is set (see Figure 84 Transfer sequencing EV5 event).

The interface waits for a read of the I2CSR1 register followed by a write in the I2CDR register with the Slave address, **holding the SCL line low**.

I²C INTERFACE (Cont'd)

Then the slave address is sent to the SDA line. In 7-bit addressing mode, one address byte is sent.

In 10-bit addressing mode, sending the first byte including the header sequence causes the I2CSR1.EVF and I2CSR1.ADD10 bits to be set by hardware with interrupt generation if the I2CCR.ITE bit is set.

Then the master waits for a read of the I2CSR1 register followed by a write in the I2CDR register, **holding the SCL line low** (see Figure 84 Transfer sequencing EV9). Then the second address byte is sent by the interface.

After each address byte, an acknowledge clock pulse is sent to the SCL line if the I2CSR1.EVF and

- I2CSR1.ADD10 bit (if first header)
- I2CSR2.ADDTX bit (if address or second header)

are set, and an interrupt is generated if the I2CCR.ITE bit is set.

The peripheral waits for a read of the I2CSR1 register followed by a write into the Control Register (I2CCR) by holding the SCL line low (see Figure 84 Transfer sequencing EV6 event).

If there was no acknowledge (I2CSR2.AF=1), the master must stop or restart the communication (set the I2CCR.START or I2CCR.STOP bits).

If there was an acknowledge, the state machine enters a sending or receiving process according to the data direction bit (least significant bit of the address), the I2CSR1.BTF flag is set and an interrupt is generated if I2CCR.ITE bit is set (see Transfer sequencing EV7, EV8 events).

If the master loses the arbitration of the bus there is no acknowledge, the I2CSR2.AF flag is set and the master must set the START or STOP bit in the control register (I2CCR). The I2CSR2.ARLO flag is set, the I2CSR1.M/SL flag is cleared and the process is reset. An interrupt is generated if I2CCR.ITE is set.

Master Transmitter:

The master waits for the microcontroller to write in the Data Register (I2CDR) or it waits for the DMA to complete **both holding the SCL line low** (see Transfer sequencing EV8).

Then the byte is received into the shift register and sent to the SDA line. When the acknowledge bit is received, the I2CSR1.BTF flag is set and an interrupt is generated if the I2CCR.ITE bit is set or the DMA is requested.

Note: In 10-bit addressing mode, to switch the master to Receiver mode, software must generate a repeated Start condition and resend the header sequence with the least significant bit set (11110xx1).

Master Receiver:

The master receives a byte from the SDA line into the shift register and sends it to the I2CDR register. It generates an acknowledge bit if the I2CCR.ACK bit is set and an interrupt if the I2CCR.ITE bit is set or a DMA is requested (see Transfer sequencing EV7 event).

Then it waits for the microcontroller to read the Data Register (I2CDR) or waits for the DMA to complete **both holding SCL line low**.

Error Cases

- **BERR:** Detection of a Stop or a Start condition during a byte transfer. The I2CSR2.BERR flag is set and an interrupt is generated if I2CCR.ITE is set.
- **AF:** Detection of a no acknowledge bit. The I2CSR2.AF flag is set and an interrupt is generated if I2CCR.ITE is set.
- **ARLO:** Arbitration Lost. The I2CSR2.ARLO flag is set, the I2CSR1.M/SL flag is cleared and the process is reset. An interrupt is generated if the I2CCR.ITE bit is set.

Note: In all cases, to resume communications, set the I2CCR.START or I2CCR.STOP bits.

Events generated by the I²C interface

- **STOP condition**
When the I2CCR.STOP bit is set, a Stop condition is generated **after the transfer** of the current byte, the I2CSR1.M/SL flag is cleared and the state machine is reset. No interrupt is generated in master mode at the detection of the stop condition.
- **START condition**
When the I2CCR.START bit is set, a start condition is generated as soon as the I²C bus is free. The I2CSR1.SB flag is set and an interrupt is generated if the I2CCR.ITE bit is set.

I²C INTERFACE (Cont'd)

Figure 84. Transfer Sequencing

7-bit Slave receiver:

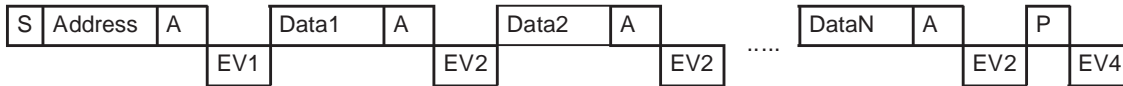

7-bit Slave transmitter:

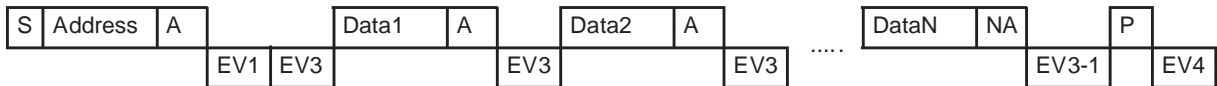

7-bit Master receiver:



7-bit Master transmitter:



10-bit Slave receiver:

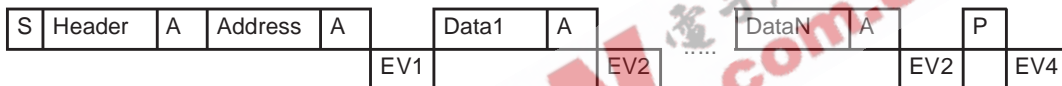

10-bit Slave transmitter:



10-bit Master transmitter



10-bit Master receiver:

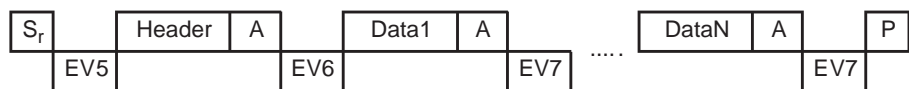

Legend:

S=Start, Sr = Repeated Start, P=Stop, A=Acknowledge, NA=Non-acknowledge, EVx=Event (with interrupt if ITE=1)

EV1: EVF=1, ADSL=1, cleared by reading SR1 register.

EV2: EVF=1, BTF=1, cleared by reading SR1 register followed by reading DR register or when DMA is complete.

EV3: EVF=1, BTF=1, cleared by reading SR1 register followed by writing DR register or when DMA is complete.

EV3-1: EVF=1, AF=1, BTF=1; AF is cleared by reading SR1 register, BTF is cleared by releasing the lines (STOP=1, STOP=0) or writing DR register (for example DR=FFh). **Note:** If lines are released by STOP=1, STOP=0 the subsequent EV4 is not seen.

EV4: EVF=1, STOPF=1, cleared by reading SR2 register.

ST92163 - I2C BUS INTERFACE

- EV5:** EVF=1, SB=1, cleared by reading SR1 register followed by writing DR register.
- EV6:** EVF=1, ADDTX=1, cleared by reading SR1 register followed by writing CR register (for example PE=1).
- EV7:** EVF=1, BTF=1, cleared by reading SR1 register followed by reading DR register or when DMA is complete.
- EV8:** EVF=1, BTF=1, cleared by reading SR1 register followed by writing DR register or when DMA is complete.
- EV9:** EVF=1, ADD10=1, cleared by reading SR1 register followed by writing DR register.

Figure 85. Event Flags and Interrupt Generation

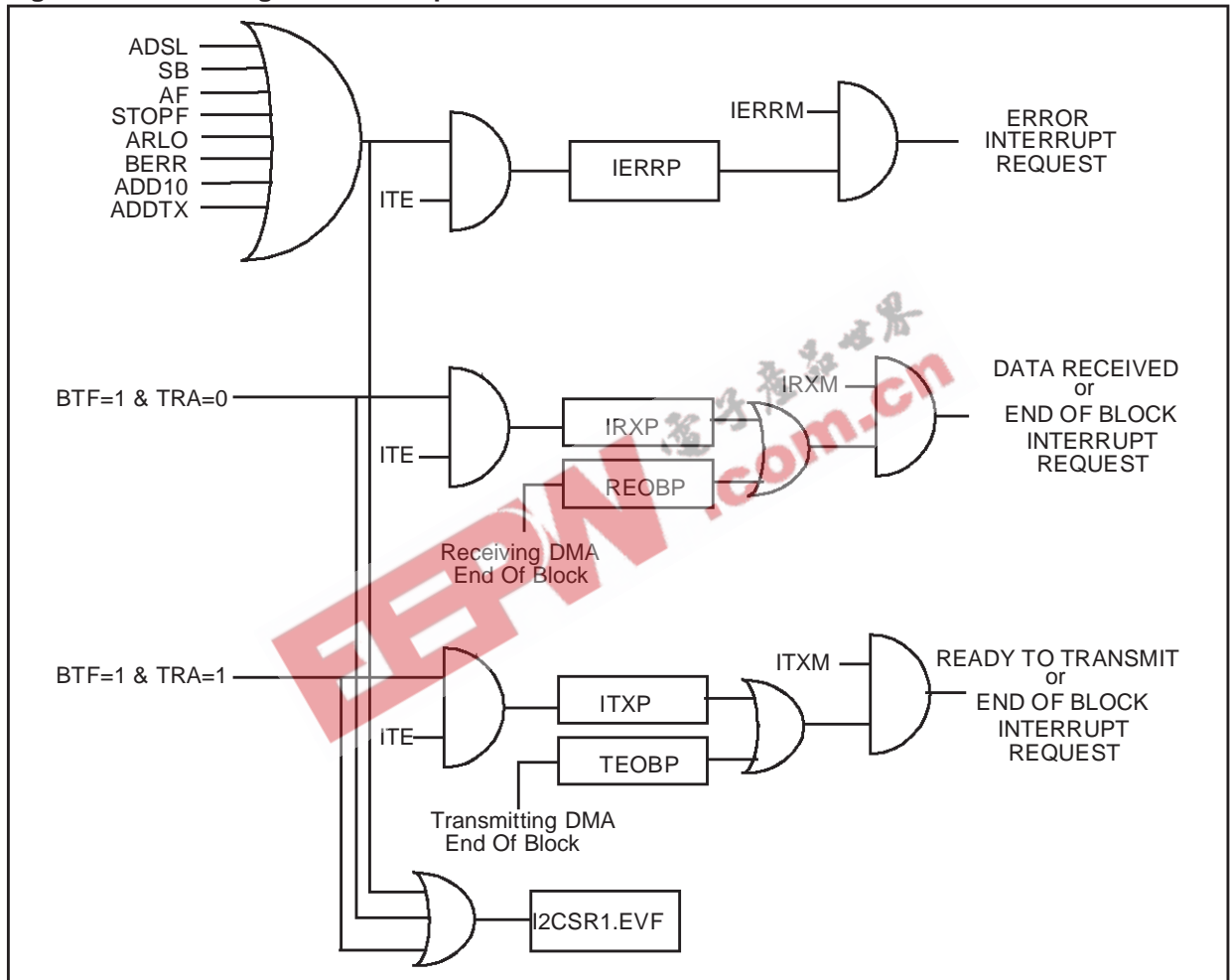

I²C INTERFACE (Cont'd)

8.5.5 Interrupt Features

The I²Cbus interface has three interrupt sources related to "Error Condition", "Peripheral Ready to Transmit" and "Data Received".

The peripheral uses the ST9+ interrupt internal protocol without requiring the use of the external interrupt channel. Dedicated registers of the peripheral should be loaded with appropriate values to set the interrupt vector (see the description of the I2CIVR register), the interrupt mask bits (see the description of the I2CIMR register) and the interrupt priority and pending bits (see the description of the I2CISR register).

The peripheral also has a global interrupt enable (the I2CCR.ITE bit) that must be set to enable the interrupt features. Moreover there is a global interrupt flag that is set when one of the interrupt events occurs (except the End Of Block interrupts - see the DMA Features section).

The "Data Received" interrupt source occurs after the acknowledge of a received data byte is performed. It is generated when the I2CSR1.BTF flag is set and the I2CSR1.TRA flag is zero.

If the DMA feature is enabled in receiver mode, this interrupt is not generated and the same interrupt vector is used to send a Receiving End Of Block interrupt (See the DMA feature section).

The "Peripheral Ready To Transmit" interrupt source occurs as soon as a data byte can be transmitted by the peripheral. It is generated when the I2CSR1.BTF and the I2CSR1.TRA flags are set.

If the DMA feature is enabled in transmitter mode, this interrupt is not generated and the same interrupt vector is used to send a Transmitting End Of Block interrupt (See the DMA feature section).

The "Error condition" interrupt source occurs when one of the following condition occurs:

- Address matched in Slave mode while I2CCR.ACK=1 (I2CSR1.ADSL and I2CSR1.EVF flags = 1)
- Start condition generated (I2CSR1.SB and I2CSR1.EVF flags = 1)
- No acknowledge received after byte transmission (I2CSR2.AF and I2CSR1.EVF flags = 1)
- Stop detected in Slave mode (I2CSR2.STOPF and I2CSR1.EVF flags = 1)

- Arbitration lost in Master mode (I2CSR2.ARLO and I2CSR1.EVF flags = 1)
- Bus error, Start or Stop condition detected during data transfer (I2CSR2.BERR and I2CSR1.EVF flags = 1)
- Master has sent the header byte (I2CSR1.ADD10 and I2CSR1.EVF flags = 1)
- Address byte successfully transmitted in Master mode. (I2CSR1.EVF = 1 and I2CSR2.ADDTX=1)

Note: Depending on the value of I2CISR.DMASTOP bit, the pending bit related to the "error condition" interrupt source is able to suspend or not suspend DMA transfers.

Each interrupt source has a dedicated interrupt address pointer vector stored in the I2CIVR register. The five more significant bits of the vector address are programmable by the customer, whereas the three less significant bits are set by hardware depending on the interrupt source:

- 010: error condition detected
- 100: data received
- 110: peripheral ready to transmit

The priority with respect to the other peripherals is programmable by setting the PRL[2:0] bits in the I2CISR register. The lowest interrupt priority is obtained by setting all the bits (this priority level is never acknowledged by the CPU and is equivalent to disabling the interrupts of the peripheral); the highest interrupt priority is programmed by resetting all the bits. See the Interrupt and DMA chapters for more details.

The internal priority of the interrupt sources of the peripheral is fixed by hardware with the following order: "Error Condition" (highest priority), "Data Received", "Peripheral Ready to Transmit".

Note: The DMA has the highest priority over the interrupts; moreover the "Transmitting End Of Block" interrupt has the same priority as the "Peripheral Ready to Transmit" interrupt and the "Receiving End Of Block" interrupt has the same priority as the "Data received" interrupt.

Each of these three interrupt sources has a pending bit (IERRP, IRXP, ITXP) in the I2CISR register that is set by hardware when the corresponding interrupt event occurs. An interrupt request is performed only if the corresponding mask bit is set (IERRM, IRXM, ITXM) in the I2CIMR register and the peripheral has a proper priority level. The pending bit has to be reset by software.

I²C INTERFACE (Cont'd)

Note: Until the pending bit is reset (while the corresponding mask bit is set), the peripheral processes an interrupt request. So, if at the end of an interrupt routine the pending bit is not reset, another interrupt request is performed.

Note: Before the end of the transmission and reception interrupt routines, the I2CSR1.BTF flag bit should be checked, to acknowledge any interrupt requests that occurred during the interrupt routine and to avoid masking subsequent interrupt requests.

Note: The "Error" event interrupt pending bit (I2CISR.IERRP) is forced high until the error event flags are set (ADD10, ADSL and SB flags of the I2CSR1 register; SCLF, ADDTX, AF, STOPF, ARLO and BERR flags of the I2CSR2 register).

Note: If the I2CISR.DMASTOP bit is reset, then the DMA has the highest priority with respect to the interrupts; if the bit is set (as after the MCU reset) and the "Error event" pending bit is set (I2CISR.IERRP), then the DMA is suspended until the pending bit is reset by software. In the second case, the "Error" interrupt sources have higher priority, followed by DMA, "Data received" and "Receiving End Of Block" interrupts, "Peripheral Ready to Transmit" and "Transmitting End Of Block".

Moreover the Transmitting End Of Block interrupt has the same priority as the "Peripheral Ready to Transmit" interrupt and the Receiving End Of Block interrupt has the same priority as the "Data received" interrupt.

8.5.6 DMA Features

The peripheral can use the ST9+ on-chip Direct Memory Access (DMA) channels to provide high-speed data transaction between the peripheral and contiguous locations of Register File, and Memory. The transactions can occur from and toward the peripheral. The maximum number of transactions that each DMA channel can perform is 222 if the register file is selected or 65536 if memory is selected. The control of the DMA features is performed using registers placed in the peripheral register page (I2CISR, I2CIMR, I2CRDAP, I2CRDC, I2CTDAP, I2CTDC).

Each DMA transfer consists of three operations:

- A load from/to the peripheral data register (I2CDR) to/from a location of Register File/Mem-

ory addressed through the DMA Address Register (or Register pair)

- A post-increment of the DMA Address Register (or Register pair)
- A post-decrement of the DMA transaction counter, which contains the number of transactions that have still to be performed.

Depending on the value of the DDCISR.DMASTOP bit the DMA feature can be suspended or not (both in transmission and in reception) until the pending bit related to the "Error event" interrupt request is set.

The priority level of the DMA features of the I²C interface with respect to the other peripherals and the CPU is the same as programmed in the I2CISR register for the interrupt sources. In the internal priority level order of the peripheral, if DDCISR.DMASTOP=0, DMA has a higher priority with respect to the interrupt sources. Otherwise (if DDCISR.DMASTOP=1), the DMA has a priority lower than "error" event interrupt sources but greater than reception and transmission interrupt sources.

Refer to the Interrupt and DMA chapters for details on the priority levels.

The DMA features are enabled by setting the corresponding enabling bits (RXDM, TXDM) in the I2CIMR register. It is possible to select also the direction of the DMA transactions.

Once the DMA transfer is completed (the transaction counter reaches 0 value), an interrupt request to the CPU is generated. This kind of interrupt is called "End Of Block". The peripheral sends two different "End Of Block" interrupts depending on the direction of the DMA (Receiving End Of Block - Transmitting End Of Block). These interrupt sources have dedicated interrupt pending bits in the I2CIMR register (REOBP, TEOBP) and they are mapped on the same interrupt vectors as respectively "Data Received" and "Peripheral Ready to Transmit" interrupt sources. The same correspondence exists about the internal priority between interrupts.

Note: The I2CCR.ITE bit has no effect on the End Of Block interrupts. Moreover, the I2CSR1.EVF flag is not set by the End Of Block interrupts.

I²C INTERFACE (Cont'd)

8.5.6.1 DMA between Peripheral and Register File

If the DMA transaction is made between the peripheral and the Register File, one register is required to hold the DMA Address and one to hold the DMA transaction counter.

These two registers must be located in the Register File:

- the DMA Address Register in the even addressed register,
- the DMA Transaction Counter in the following register (odd address).

They are pointed to by the DMA Transaction Counter Pointer Register (I2CRDC register in receiving, I2CTDC register in transmitting) located in the peripheral register page.

In order to select the DMA transaction with the Register File, the control bit I2CRDC.RF/MEM in receiving mode or I2CTDC.RF/MEM in transmitting mode must be set.

The transaction Counter Register must be initialized with the number of DMA transfers to perform and will be decremented after each transaction. The DMA Address Register must be initialized with the starting address of the DMA table in the Register File, and it is increased after each transaction. These two registers must be located between addresses 00h and DFh of the Register File.

When the DMA occurs between Peripheral and Register File, the I2CTDAP register (in transmission) and the I2CRDAP one (in reception) are not used.

8.5.6.2 DMA between Peripheral and Memory Space

If the DMA transaction is made between the peripheral and Memory, a register pair is required to hold the DMA Address and another register pair to hold the DMA Transaction counter. These two pairs of registers must be located in the Register File. The DMA Address pair is pointed to by the DMA Address Pointer Register (I2CRDAP register in reception, I2CTDAP register in transmission) located in the peripheral register page; the DMA Transaction Counter pair is pointed to by the DMA Transaction Counter Pointer Register (I2CRDC register in reception, I2CTDC register in transmission) located in the peripheral register page.

In order to select the DMA transaction with the Memory Space, the control bit I2CRDC.RF/MEM in receiving mode or I2CTDC.RF/MEM in transmitting mode must be reset.

The Transaction Counter registers pair must be initialized with the number of DMA transfers to perform and will be decremented after each transaction. The DMA Address register pair must be initialized with the starting address of the DMA table in the Memory Space, and it is increased after each transaction. These two register pairs must be located between addresses 00h and DFh of the Register File.

8.5.6.3 DMA in Master Receive

To correctly manage the reception of the last byte when the DMA in Master Receive mode is used, the following sequence of operations must be performed:

1. The number of data bytes to be received must be set to the effective number of bytes minus one byte.
2. When the Receiving End Of Block condition occurs, the I2CCR.STOP bit must be set and the I2CCR.ACK bit must be reset.

The last byte of the reception sequence can be received either using interrupts/polling or using DMA. If the user wants to receive the last byte using DMA, the number of bytes to be received must be set to 1, and the DMA in reception must be re-enabled (IMR.RXDM bit set) to receive the last byte. Moreover the Receiving End Of Block interrupt service routine must be designed to recognize and manage the two different End Of Block situations (after the first sequence of data bytes and after the last data byte).

I²C INTERFACE (Cont'd)

8.5.7 Register Description

IMPORTANT:

- To guarantee correct operation, before enabling the peripheral (while I2CCR.PE=0), configure bit7 and bit6 of the I2COAR2 register according to the internal clock INTCLK (for example 11xxxxxb in the range 14 - 30 MHz).
- Bit7 of the I2CCR register must be cleared.

I²C CONTROL REGISTER (I2CCR)

R240 - Read / Write

Register Page: 20

Reset Value: 0000 0000 (00h)

7							0
0	0	PE	ENGC	START	ACK	STOP	ITE

Bit 7:6 = **Reserved**
Must be cleared

Bit 5 = **PE Peripheral Enable.**

This bit is set and cleared by software.

0: Peripheral disabled (reset value)

1: Master/Slave capability

Notes:

- When I2CCR.PE=0, all the bits of the I2CCR register and the I2CSR1-I2CSR2 registers except the STOP bit are reset. All outputs will be released while I2CCR.PE=0
- When I2CCR.PE=1, the corresponding I/O pins are selected by hardware as alternate functions (open drain).
- To enable the I²C interface, write the I2CCR register **TWICE** with I2CCR.PE=1 as the first write only activates the interface (only I2CCR.PE is set).
- When PE=1, the FREQ[2:0] and EN10BIT bits in the I2COAR2 and I2CADR registers cannot be written. The value of these bits can be changed only when PE=0.

Bit 4 = **ENGC General Call address enable.**

Setting this bit the peripheral works as a slave and the value stored in the I2CADR register is recognized as device address.

This bit is set and cleared by software. It is also cleared by hardware when the interface is disabled (I2CCR.PE=0).

0: The address stored in the I2CADR register is ignored (reset value)

1: The General Call address stored in the I2CADR register will be acknowledged

Note: The correct value (usually 00h) must be written in the I2CADR register before enabling the General Call feature.

Bit 3 = **START Generation of a Start condition.**

This bit is set and cleared by software. It is also cleared by hardware when the interface is disabled (I2CCR.PE=0) or when the Start condition is sent (with interrupt generation if ITE=1).

– In master mode:

0: No start generation

1: Repeated start generation

– In slave mode:

0: No start generation (reset value)

1: Start generation when the bus is free

Bit 2 = **ACK Acknowledge enable.**

This bit is set and cleared by software. It is also cleared by hardware when the interface is disabled (I2CCR.PE=0).

0: No acknowledge returned (reset value)

1: Acknowledge returned after an address byte or a data byte is received

Bit 1 = **STOP Generation of a Stop condition.**

This bit is set and cleared by software. It is also cleared by hardware in master mode. It is not cleared when the interface is disabled (I2CCR.PE=0). In slave mode, this bit must be set only when I2CSR1.BTF=1.

– In master mode:

0: No stop generation

1: Stop generation after the current byte transfer or after the current Start condition is sent. The STOP bit is cleared by hardware when the Stop condition is sent.

– In slave mode:

0: No stop generation (reset value)

1: Release SCL and SDA lines after the current byte transfer (I2CSR1.BTF=1). In this mode the STOP bit has to be cleared by software.

I²C INTERFACE (Cont'd)

Bit 0 = **ITE** *Interrupt Enable*.

The ITE bit enables the generation of interrupts. This bit is set and cleared by software and cleared by hardware when the interface is disabled (I2CCR.PE=0).

0: Interrupts disabled (reset value)

1: Interrupts enabled after any of the following conditions:

- Byte received or to be transmitted (I2CSR1.BTF and I2CSR1.EVF flags = 1)
- Address matched in Slave mode while I2CCR.ACK=1 (I2CSR1.ADSL and I2CSR1.EVF flags = 1)
- Start condition generated (I2CSR1.SB and I2CSR1.EVF flags = 1)
- No acknowledge received after byte transmission (I2CSR2.AF and I2CSR1.EVF flags = 1)
- Stop detected in Slave mode (I2CSR2.STOPF and I2CSR1.EVF flags = 1)
- Arbitration lost in Master mode (I2CSR2.ARLO and I2CSR1.EVF flags = 1)
- Bus error, Start or Stop condition detected during data transfer (I2CSR2.BERR and I2CSR1.EVF flags = 1)
- Master has sent header byte (I2CSR1.ADD10 and I2CSR1.EVF flags = 1)
- Address byte successfully transmitted in Master mode. (I2CSR1.EVF = 1 and I2CSR2.ADDTX = 1)

SCL is held low when the ADDTX flag of the I2CSR2 register or the ADD10, SB, BTF or ADSL flags of I2CSR1 register are set (See Figure 84) or when the DMA is not complete.

The transfer is suspended in all cases except when the BTF bit is set and the DMA is enabled. In this case the event routine must suspend the DMA transfer if it is required.

I²C STATUS REGISTER 1 (I2CSR1)

R241 - Read Only

Register Page: 20

Reset Value: 0000 0000 (00h)

7							0
EVF	ADD10	TRA	BUSY	BTF	ADSL	M/SL	SB

Note: Some bits of this register are reset by a read operation of the register. Care must be taken when using instructions that work on single bit. Some of them perform a read of all the bits of the register before modifying or testing the wanted bit. So other bits of the register could be affected by the operation.

In the same way, the test/compare operations perform a read operation.

Moreover, if some interrupt events occur while the register is read, the corresponding flags are set, and correctly read, but if the read operation resets the flags, no interrupt request occurs.

Bit 7 = **EVF** *Event Flag*.

This bit is set by hardware as soon as an event (listed below or described in Figure 84) occurs. It is cleared by software when all event conditions that set the flag are cleared. It is also cleared by hardware when the interface is disabled (I2CCR.PE=0).

0: No event

1: One of the following events has occurred:

- Byte received or to be transmitted (I2CSR1.BTF and I2CSR1.EVF flags = 1)
- Address matched in Slave mode while I2CCR.ACK=1 (I2CSR1.ADSL and I2CSR1.EVF flags = 1)
- Start condition generated (I2CSR1.SB and I2CSR1.EVF flags = 1)
- No acknowledge received after byte transmission (I2CSR2.AF and I2CSR1.EVF flags = 1)
- Stop detected in Slave mode (I2CSR2.STOPF and I2CSR1.EVF flags = 1)
- Arbitration lost in Master mode (I2CSR2.ARLO and I2CSR1.EVF flags = 1)
- Bus error, Start or Stop condition detected during data transfer (I2CSR2.BERR and I2CSR1.EVF flags = 1)
- Master has sent header byte (I2CSR1.ADD10 and I2CSR1.EVF flags = 1)

I²C INTERFACE (Cont'd)

- Address byte successfully transmitted in Master mode.
(I2CSR1.EVF = 1 and I2CSR2.ADDTX=1)

Bit 6 = ADD10 10-bit addressing in Master mode.
This bit is set when the master has sent the first byte in 10-bit address mode. An interrupt is generated if ITE=1.
It is cleared by software reading I2CSR1 register followed by a write in the I2CDR register of the second address byte. It is also cleared by hardware when peripheral is disabled (I2CCR.PE=0) or when the STOPF bit is set.

0: No ADD10 event occurred.
1: Master has sent first address byte (header).

Bit 5 = TRA Transmitter/ Receiver.
When BTF flag of this register is set and also TRA=1, then a data byte has to be transmitted. It is cleared automatically when BTF is cleared. It is also cleared by hardware after the STOPF flag of I2CSR2 register is set, loss of bus arbitration (ARLO flag of I2CSR2 register is set) or when the interface is disabled (I2CCR.PE=0).
0: A data byte is received (if I2CSR1.BTF=1)
1: A data byte can be transmitted (if I2CSR1.BTF=1)

Bit 4 = BUSY Bus Busy.
It indicates a communication in progress on the bus. The detection of the communications is always active (even if the peripheral is disabled). This bit is set by hardware on detection of a Start condition and cleared by hardware on detection of a Stop condition. This information is still updated when the interface is disabled (I2CCR.PE=0).
0: No communication on the bus
1: Communication ongoing on the bus

Bit 3 = BTF Byte Transfer Finished.
This bit is set by hardware as soon as a byte is correctly received or before the transmission of a data byte with interrupt generation if ITE=1. It is cleared by software reading I2CSR1 register followed by a read or write of I2CDR register or when DMA is complete. It is also cleared by hardware when the interface is disabled (I2CCR.PE=0).

- Following a byte transmission, this bit is set after reception of the acknowledge clock pulse. BTF is cleared by reading I2CSR1 register followed by writing the next byte in I2CDR register or when DMA is complete.
- Following a byte reception, this bit is set after transmission of the acknowledge clock pulse if ACK=1. BTF is cleared by reading I2CSR1 register followed by reading the byte from I2CDR register or when DMA is complete.

The SCL line is held low while I2CSR1.BTF=1.
0: Byte transfer not done
1: Byte transfer succeeded

Bit 2 = ADSL Address matched (Slave mode).
This bit is set by hardware if the received slave address matches the I2COAR1/I2COAR2 register content or a General Call address. An interrupt is generated if ITE=1. It is cleared by software reading I2CSR1 register or by hardware when the interface is disabled (I2CCR.PE=0). The SCL line is held low while ADSL=1.
0: Address mismatched or not received
1: Received address matched

Bit 1 = M/SL Master/Slave.
This bit is set by hardware as soon as the interface is in Master mode (Start condition generated on the lines after the I2CCR.START bit is set). It is cleared by hardware after detecting a Stop condition on the bus or a loss of arbitration (ARLO=1). It is also cleared when the interface is disabled (I2CCR.PE=0).
0: Slave mode
1: Master mode

Bit 0 = SB Start Bit (Master mode).
This bit is set by hardware as soon as the Start condition is generated (following a write of START=1 if the bus is free). An interrupt is generated if ITE=1. It is cleared by software reading I2CSR1 register followed by writing the address byte in I2CDR register. It is also cleared by hardware when the interface is disabled (I2CCR.PE=0).
The SCL line is held low while SB=1.
0: No Start condition
1: Start condition generated

I²C INTERFACE (Cont'd)**I²C STATUS REGISTER 2 (I2CSR2)**

R242 - Read Only

Register Page: 20

Reset Value: 0000 0000 (00h)

7							0
0	0	ADDTX	AF	STOPF	ARLO	BERR	GCAL

Note: Some bits of this register are reset by a read operation of the register. Care must be taken when using instructions that work on single bit. Some of them perform a read of all the bits of the register before modifying or testing the wanted bit. So other bits of the register could be affected by the operation.

In the same way, the test/compare operations perform a read operation.

Moreover, if some interrupt events occur while the register is read, the corresponding flags are set, and correctly read, but if the read operation resets the flags, no interrupt request occurs.

Bit 7:6 = Reserved. Forced to 0 by hardware.

Bit 5 = **ADDTX** Address or 2nd header transmitted in Master mode.

This bit is set by hardware when the peripheral, enabled in Master mode, has received the acknowledge relative to:

- Address byte in 7-bit mode
 - Address or 2nd header byte in 10-bit mode.
- 0: No address or 2nd header byte transmitted
1: Address or 2nd header byte transmitted.

Bit 4 = **AF** Acknowledge Failure.

This bit is set by hardware when no acknowledge is returned. An interrupt is generated if ITE=1.

It is cleared by software reading I2CSR2 register **after the falling edge of the acknowledge SCL pulse**, or by hardware when the interface is disabled (I2CCR.PE=0).

The SCL line is not held low while AF=1.

- 0: No acknowledge failure detected
1: A data or address byte was not acknowledged

Bit 3 = **STOPF** Stop Detection (Slave mode).

This bit is set by hardware when a Stop condition is detected on the bus after an acknowledge. An interrupt is generated if ITE=1.

It is cleared by software reading I2CSR2 register or by hardware when the interface is disabled (I2CCR.PE=0).

The SCL line is not held low while STOPF=1.

0: No Stop condition detected

1: Stop condition detected (**while slave receiver**)

Bit 2 = **ARLO** Arbitration Lost.

This bit is set by hardware when the interface (in master mode) loses the arbitration of the bus to another master. An interrupt is generated if ITE=1.

It is cleared by software reading I2CSR2 register or by hardware when the interface is disabled (I2CCR.PE=0).

After an ARLO event the interface switches back automatically to Slave mode (M/SL=0).

The SCL line is not held low while ARLO=1.

0: No arbitration lost detected

1: Arbitration lost detected

Bit 1 = **BERR** Bus Error.

This bit is set by hardware when the interface detects a Start or Stop condition during a byte transfer. An interrupt is generated if ITE=1.

It is cleared by software reading I2CSR2 register or by hardware when the interface is disabled (I2CCR.PE=0).

The SCL line is not held low while BERR=1.

Note: If a misplaced start condition is detected, also the **ARLO** flag is set; moreover, if a misplaced stop condition is placed on the acknowledge SCL pulse, also the **AF** flag is set.

0: No Start or Stop condition detected during byte transfer

1: Start or Stop condition detected during byte transfer

Bit 0 = **GCAL** General Call address matched.

This bit is set by hardware after an address matches with the value stored in the I2CADR register while ENGCG=1. In the I2CADR the General Call address must be placed before enabling the peripheral.

It is cleared by hardware after the detection of a Stop condition, or when the peripheral is disabled (I2CCR.PE=0).

0: No match

1: General Call address matched.

I²C INTERFACE (Cont'd)

I²C CLOCK CONTROL REGISTER (I2CCCR)

R243 - Read / Write
 Register Page: 20
 Reset Value: 0000 0000 (00h)

7							0
FM/SM	CC6	CC5	CC4	CC3	CC2	CC1	CC0

Bit 7 = **FM/SM** *Fast/Standard I²C mode*.
 This bit is used to select between fast and standard mode. See the description of the following bits. It is set and cleared by software. It is not cleared when the peripheral is disabled (I2CCR.PE=0)

Bit 6:0 = **CC[6:0]** *9-bit divider programming*
 Implementation of a programmable clock divider. These bits and the CC[8:7] bits of the I2CECCR register select the speed of the bus (F_{SCL}) depending on the I²C mode. They are not cleared when the interface is disabled (I2CCR.PE=0).

- Standard mode (FM/SM=0): F_{SCL} ≤ 100kHz

$$F_{SCL} = INTCLK / (2 \times ([CC8..CC0] + 2))$$
- Fast mode (FM/SM=1): F_{SCL} > 100kHz

$$F_{SCL} = INTCLK / (3 \times ([CC8..CC0] + 2))$$

Note: The programmed frequency is available with no load on SCL and SDA pins.

I²C OWN ADDRESS REGISTER 1 (I2COAR1)

R244 - Read / Write
 Register Page: 20
 Reset Value: 0000 0000 (00h)

7							0
ADD7	ADD6	ADD5	ADD4	ADD3	ADD2	ADD1	ADD0

7-bit Addressing Mode

Bit 7:1 = **ADD[7:1]** *Interface address*.
 These bits define the I²C bus address of the interface. They are not cleared when the interface is disabled (I2CCR.PE=0).

Bit 0 = **ADD0** *Address direction bit*.
 This bit is don't care; the interface acknowledges either 0 or 1.

It is not cleared when the interface is disabled (I2CCR.PE=0).

Note: Address 01h is always ignored.

10-bit Addressing Mode

Bit 7:0 = **ADD[7:0]** *Interface address*.
 These are the least significant bits of the I²C bus address of the interface. They are not cleared when the interface is disabled (I2CCR.PE=0).

I²C INTERFACE (Cont'd)**I²C OWN ADDRESS REGISTER 2 (I2COAR2)**

R245 - Read / Write

Register Page: 20

Reset Value: 0000 0000 (00h)

7							0
FREQ1	FREQ0	EN10BIT	FREQ2	0	ADD9	ADD8	0

Bit 7:6,4 = **FREQ[2:0]** *Frequency bits.*

IMPORTANT: To guarantee correct operation, set these bits before enabling the interface (while I2CCR.PE=0).

These bits can be set only when the interface is disabled (I2CCR.PE=0). To configure the interface to I²C specified delays, select the value corresponding to the microcontroller internal frequency INTCLK.

INTCLK Range (MHz)	FREQ2	FREQ1	FREQ0
2.5 - 6	0	0	0
6 - 10	0	0	1
10 - 14	0	1	0
14 - 30	0	1	1
30 - 50	1	0	0

Note: If an incorrect value, with respect to the MCU internal frequency, is written in these bits, the timings of the peripheral will not meet the I²C bus standard requirements.

Note: The FREQ[2:0] = 101, 110, 111 configurations must not be used.

Bit 5 = **EN10BIT** *Enable 10-bit I²Cbus mode.*

When this bit is set, the 10-bit I²Cbus mode is enabled.

This bit can be written only when the peripheral is disabled (I2CCR.PE=0).

0: 7-bit mode selected

1: 10-bit mode selected

Bit 4:3 = Reserved.

Bit 2:1 = **ADD[9:8]** *Interface address.*

These are the most significant bits of the I²Cbus

address of the interface (10-bit mode only). They are not cleared when the interface is disabled (I2CCR.PE=0).

Bit 0 = Reserved.

I²C DATA REGISTER (I2CDR)

R246 - Read / Write

Register Page: 20

Reset Value: 0000 0000 (00h)

7							0
DR7	DR6	DR5	DR4	DR3	DR2	DR1	DR0

Bit 7:0 = **DR[7:0]** *I2C Data.*

– In transmitter mode:

I2CDR contains the next byte of data to be transmitted. The byte transmission begins after the microcontroller has written in I2CDR or on the next rising edge of the clock if DMA is complete.

– In receiver mode:

I2CDR contains the last byte of data received. The next byte receipt begins after the I2CDR read by the microcontroller or on the next rising edge of the clock if DMA is complete.

GENERAL CALL ADDRESS (I2CADR)

R247 - Read / Write

Register Page: 20

Reset Value: 1010 0000 (A0h)

7							0
ADR7	ADR6	ADR5	ADR4	ADR3	ADR2	ADR1	ADR0

Bit 7:0 = **ADR[7:0]** *Interface address.*

These bits define the I²Cbus General Call address of the interface. It must be written with the correct value depending on the use of the peripheral. If the peripheral is used in I²C bus mode, the 00h value must be loaded as General Call address.

The customer could load the register with other values.

The bits can be written only when the peripheral is disabled (I2CCR.PE=0)

The ADR0 bit is don't care; the interface acknowledges either 0 or 1.

Note: Address 01h is always ignored.

I²C INTERFACE (Cont'd)

INTERRUPT STATUS REGISTER (I2CISR)

R248 - Read / Write

Register Page: 20

Reset Value: 1xxx xxxx (xxh)

7					0			
DMASTOP	PRL2	PRL1	PRL0	0	IERRP	IRXP	ITXP	

Bit 7 = **DMASTOP** DMA suspended mode. This bit selects between DMA suspended mode and DMA not suspended mode.

In DMA Suspended mode, if the error interrupt pending bit (I2CISR.IERRP) is set, no DMA request is performed. DMA requests are performed only when IERRP=0. Moreover the "Error Condition" interrupt source has a higher priority than the DMA.

In DMA Not-Suspended mode, the status of IERRP bit has no effect on DMA requests. Moreover the DMA has higher priority with respect to other interrupt sources.

0: DMA Not-Suspended mode

1: DMA Suspended mode

Bit 6:4 = **PRL[2:0]** Interrupt/DMA Priority Bits.

The priority is encoded with these three bits. The value of "0" has the highest priority, the value "7" has no priority. After the setting of this priority level, the priorities between the different Interrupt/DMA sources is hardware defined according with the following scheme:

- Error condition Interrupt (If DMASTOP=1) (Highest priority)
- Receiver DMA request
- Transmitter DMA request
- Error Condition Interrupt (If DMASTOP=0)
- Data Received/Receiver End Of Block
- Peripheral Ready To Transmit/Transmitter End Of Block (Lowest priority)

Bit 3 = Reserved.

Must be cleared.

Bit 2 = **IERRP** Error Condition pending bit

0: No error

1: Error event detected (if ITE=1)

Note: Depending on the status of the I2CISR.DMASTOP bit, this flag can suspend or not suspend the DMA requests.

Note: The Interrupt pending bits can be reset by writing a "0" but is not possible to write a "1". It is mandatory to clear the interrupt source by writing a "0" in the pending bit when executing the interrupt service routine. When serving an interrupt routine, the user should reset ONLY the pending bit related to the served interrupt routine (and not reset the other pending bits).

To detect the specific error condition that occurred, the flag bits of the I2CSR1 and I2CSR2 register should be checked.

Note: The IERRP pending bit is forced high until the error event flags are set (ADSL and SB flags in the I2CSR1 register, SCLF, ADDTX, AF, STOPF, ARLO and BERR flags in the I2CSR2 register). If at least one flag is set, it is not possible to reset the IERRP bit.

Bit 1 = **IRXP** Data Received pending bit

0: No data received

1: data received (if ITE=1).

Bit 0 = **ITXP** Peripheral Ready To Transmit pending bit

0: Peripheral not ready to transmit

1: Peripheral ready to transmit a data byte (if ITE=1).

I²C INTERFACE (Cont'd)**INTERRUPT VECTOR REGISTER (I2CIVR)**

R249 - Read / Write

Register Page: 20

Reset Value: Undefined

7							0
V7	V6	V5	V4	V3	EV2	EV1	0

Bit 7:3 = **V[7:3]** *Interrupt Vector Base Address*.
User programmable interrupt vector bits. These are the five more significant bits of the interrupt vector base address. They must be set before enabling the interrupt features.

Bit 2:1 = **EV[2:1]** *Encoded Interrupt Source*.

These Read-Only bits are set by hardware according to the interrupt source:

- 01: error condition detected
- 10: data received
- 11: peripheral ready to transmit

Bit 0 = Reserved.

Forced by hardware to 0.

RECEIVER DMA SOURCE ADDRESS POINTER REGISTER (I2CRDAP)

R250 - Read / Write

Register Page: 20

Reset Value: Undefined

7							0
RA7	RA6	RA5	RA4	RA3	RA2	RA1	RPS

Bit 7:1 = **RA[7:1]** *Receiver DMA Address Pointer*.
I2CRDAP contains the address of the pointer (in the Register File) of the Receiver DMA data source when the DMA is selected between the peripheral and the Memory Space. Otherwise,

(DMA between peripheral and Register file), this register has no meaning.

See Section 8.5.6.1 for more details on the use of this register.

Bit 0 = **RPS** *Receiver DMA Memory Pointer Selector*.

If memory has been selected for DMA transfer (DDCRDC.RF/MEM = 0) then:

- 0: Select ISR register for Receiver DMA transfer address extension.
- 1: Select DMASR register for Receiver DMA transfer address extension.

RECEIVER DMA TRANSACTION COUNTER REGISTER (I2CRDC)

R251 - Read / Write

Register Page: 20

Reset Value: Undefined

7							0
RC7	RC6	RC5	RC4	RC3	RC2	RC1	RF/MEM

Bit 7:1 = **RC[7:1]** *Receiver DMA Counter Pointer*.
I2CRDC contains the address of the pointer (in the Register File) of the DMA receiver transaction counter when the DMA between Peripheral and Memory Space is selected. Otherwise (DMA between Peripheral and Register File), this register points to a pair of registers that are used as DMA Address register and DMA Transaction Counter. See Section 8.5.6.1 and Section 8.5.6.2 for more details on the use of this register.

Bit 0 = **RF/MEM** *Receiver Register File/ Memory Selector*.

0: DMA towards Memory

1: DMA towards Register file

I²C INTERFACE (Cont'd)

TRANSMITTER DMA SOURCE ADDRESS POINTER REGISTER (I2CTDAP)

R252 - Read / Write
 Register Page: 20
 Reset Value: Undefined

7							0
TA7	TA6	TA5	TA4	TA3	TA2	TA1	TPS

Bit 7:1 = **TA[7:1]** *Transmit DMA Address Pointer.*
 I2CTDAP contains the address of the pointer (in the Register File) of the Transmitter DMA data source when the DMA between the peripheral and the Memory Space is selected. Otherwise (DMA between the peripheral and Register file), this register has no meaning.
 See Section 8.5.6.2 for more details on the use of this register.

Bit 0 = **TPS** *Transmitter DMA Memory Pointer Selector.*

If memory has been selected for DMA transfer (DDCTDC.RF/MEM = 0) then:
 0: Select ISR register for transmitter DMA transfer address extension.
 1: Select DMASR register for transmitter DMA transfer address extension.

TRANSMITTER DMA TRANSACTION COUNTER REGISTER (I2CTDC)

R253 - Read / Write
 Register Page: 20
 Reset Value: Undefined

7							0
TC7	TC6	TC5	TC4	TC3	TC2	TC1	RF/MEM

Bit 7:1 = **TC[7:1]** *Transmit DMA Counter Pointer.*
 I2CTDC contains the address of the pointer (in the Register File) of the DMA transmitter transaction counter when the DMA between Peripheral and Memory Space is selected. Otherwise, if the DMA between Peripheral and Register File is selected, this register points to a pair of registers that are used as DMA Address register and DMA Transaction Counter.

See Section 8.5.6.1 and Section 8.5.6.2 for more details on the use of this register.

Bit 0 = **RF/MEM** *Transmitter Register File/ Memory Selector.*

0: DMA from Memory
 1: DMA from Register file

EXTENDED CLOCK CONTROL REGISTER (I2CECCR)

R254 - Read / Write
 Register Page: 20
 Reset Value: 0000 0000 (00h)

7							0
0	0	0	0	0	0	CC8	CC7

Bit 7:2 = Reserved. Must always be cleared.

Bit 1:0 = **CC[8:7]** *9-bit divider programming*
 Implementation of a programmable clock divider. These bits and the CC[6:0] bits of the I2CCCR register select the speed of the bus (F_{SCL}). For a description of the use of these bits, see the I2CCCR register.
 They are not cleared when the interface is disabled (I2CCCR.PE=0).

I²C INTERFACE (Cont'd)

INTERRUPT MASK REGISTER (I2CIMR)

R255 - Read / Write

Register Page: 20

Reset Value: 00xx 0000 (x0h)

7							0
RXD M	TXD M	REOBP	TEOBP	0	IERR M	IRX M	ITX M

Bit 7 = **RXDM Receiver DMA Mask.**

0: DMA reception disable.

1: DMA reception enable

RXDM is reset by hardware when the transaction counter value decrements to zero, that is when a Receiver End Of Block interrupt is issued.

Bit 6 = **TXDM Transmitter DMA Mask.**

0: DMA transmission disable.

1: DMA transmission enable.

TXDM is reset by hardware when the transaction counter value decrements to zero, that is when a Transmitter End Of Block interrupt is issued.

Bit 5 = **REOBP Receiver DMA End Of Block Flag.** REOBP should be reset by software in order to avoid undesired interrupt routines, especially in initialization routine (after reset) and after entering the End Of Block interrupt routine. Writing "0" in this bit will cancel the interrupt request

Note: REOBP can only be written to "0".

0: End of block not reached.

1: End of data block in DMA receiver detected

Bit 4 = **TEOBP Transmitter DMA End Of Block** TEOBP should be reset by software in order to avoid undesired interrupt routines, especially in initialization routine (after reset) and after entering the End Of Block interrupt routine. Writing "0" will cancel the

interrupt request.

Note: TEOBP can only be written to "0".

0: End of block not reached

1: End of data block in DMA transmitter detected.

Bit 3 = Reserved. This bit **must** be cleared.

Bit 2 = **IERRM Error Condition interrupt mask bit.**

This bit enables/ disables the Error interrupt.

0: Error interrupt disabled.

1: Error Interrupt enabled.

Bit 1 = **IRXM Data Received interrupt mask bit.**

This bit enables/ disables the Data Received and Receive DMA End of Block interrupts.

0: Interrupts disabled

1: Interrupts enabled

Note: This bit has no effect on DMA transfer

Bit 0 = **ITXM Peripheral Ready To Transmit interrupt mask bit.**

This bit enables/ disables the Peripheral Ready To Transmit and Transmit DMA End of Block interrupts.

0: Interrupts disabled

1: Interrupts enabled

Note: This bit has no effect on DMA transfer.

ST92163 - I2C BUS INTERFACE

I²C INTERFACE (Cont'd)

Table 36. I²C BUS Register Map and Reset Values

Address (Hex.)	Register Name	7	6	5	4	3	2	1	0
F0h	I2CCR Reset Value	- 0	- 0	PE 0	ENGC 0	START 0	ACK 0	STOP 0	ITE 0
F1h	I2CSR1 Reset Value	EVF 0	ADD10 0	TRA 0	BUSY 0	BTF 0	ADSL 0	M/SL 0	SB 0
F2h	I2CSR2 Reset Value	- 0	0 0	ADDTX 0	AF 0	STOPF 0	ARLO 0	BERR 0	GCAL 0
F3h	I2CCCR Reset Value	FM/SM 0	CC6 0	CC5 0	CC4 0	CC3 0	CC2 0	CC1 0	CC0 0
F4h	I2COAR1 Reset Value	ADD7 0	ADD6 0	ADD5 0	ADD4 0	ADD3 0	ADD2 0	ADD1 0	ADD0 0
F5h	I2COAR2 Reset Value	FREQ1 0	FREQ0 0	EN10BIT 0	FREQ2 0	0 0	ADD9 0	ADD8 0	0 0
F6h	I2CDR Reset Value	DR7 0	DR6 0	DR5 0	DR4 0	DR3 0	DR2 0	DR1 0	DR0 0
F7h	I2CADR Reset Value	ADR7 1	ADR6 0	ADR5 1	ADR4 0	ADR3 0	ADR2 0	ADR1 0	ADR0 0
F8h	I2CISR Reset Value	DMASTOP 1	PRL2 X	PRL1 X	PRL0 X	X	IERRP X	IRXP X	ITXP X
F9h	I2CIVR Reset Value	V7 X	V6 X	V5 X	V4 X	V3 X	EV2 X	EV1 X	0 0
FAh	I2CRDAP Reset Value	RA7 X	RA6 X	RA5 X	RA4 X	RA3 X	RA2 X	RA1 X	RPS X
FBh	I2CRDC Reset Value	RC7 X	RC6 X	RC5 X	RC4 X	RC3 X	RC2 X	RC1 X	RF/MEM X
FCh	I2CTDAP Reset Value	TA7 X	TA6 X	TA5 X	TA4 X	TA3 X	TA2 X	TA1 X	TPS X
FDh	I2CTDC Reset Value	TC7 X	TC6 X	TC5 X	TC4 X	TC3 X	TC2 X	TC1 X	RF/MEM X
FEh	I2CECCR	0 0	0 0	0 0	0 0	0 0	0 0	CC8 0	CC7 0
FFh	I2CIMR Reset Value	RXDM 0	TXDM 0	REOBP X	TEOBP X	0	IERRM 0	IRXM 0	ITXM 0

A/D CONVERTER (Cont'd)

The conversion technique used is successive approximation, with AC coupled analog fully differential comparators blocks plus a Sample and Hold logic and a reference generator.

The internal reference (DAC) is based on the use of a binary-ratioed capacitor array. This technique allows the specified monotonicity (using the same ratioed capacitors as sampling capacitor). A Power Down programmable bit sets the A/D converter analog section to a zero consumption idle status.

8.6.3.1 Operating Modes

The two main operating modes, single and continuous, can be selected by writing 0 (reset value) or 1 into the CONT bit of the Control Logic Register.

Single Mode

In single mode (CONT=0 in ADCLR) the STR bit is forced to '0' after the end of channel i-th conversion; then the A/D waits for a new start event. This mode is useful when a set of signals must be sampled at a fixed frequency imposed by a Timer unit or an external generator (through the alternate synchronization feature). A simple software routine monitoring the STR bit can be used to save the current value before a new conversion ends (so to create a signal samples table within the internal memory or the Register File). Furthermore, if the R242.0 bit (register AD-INT, bit 0) is set, at the end of conversion a negative edge on the connected external interrupt channel (see Interrupts Chapter) is generated to allow the reading of the converted data by means of an interrupt routine.

Continuous Mode

In continuous mode (CONT=1 in ADCLR) a continuous conversion flow is entered by a start event on the selected channel until the STR bit is reset by software.

At the end of each conversion, the Data Register (ADCDR) content is updated with the last conversion result, while the former value is lost. When the conversion flow is stopped, an interrupt request is generated with the same modality previously described.

8.6.3.2 Alternate Synchronization

This feature is available in both single/continuous modes. The negative edge of external EXTRG signal or the occurrence of an on-chip event generated by another peripheral can be used to synchronize the conversion start with a trigger pulse.

These events can be enabled or masked by programming the TRG bit in the ADCLR Register.

The effect of alternate synchronization is to set the STR bit, which is cleared by hardware at the end of each conversion in single mode. In continuous mode any trigger pulse following the first one will be ignored. The synchronization source must provide a pulse (1.5 internal system clock, 125ns @ 12 MHz internal clock) of minimum width, and a period greater (in single mode) than the conversion time (~6.5us @ 12 MHz internal clock). If a trigger occurs when the STR bit is still '1' (conversions still in progress), it is ignored (see Electrical Characteristics).

WARNING: If the EXTRG or INTRG signals are already active when TRG bit is set, the conversion starts immediately.

8.6.3.3 Power-Up Operations

Before enabling any A/D operation mode, set the POW bit of the ADCLR Register at least 60 μs before the first conversion starts to enable the biasing circuits inside the analog section of the converter. Clearing the POW bit is useful when the A/D is not used so reducing the total chip power consumption. This state is also the reset configuration and it is forced by hardware when the core is in HALT state (after a HALT instruction execution).

8.6.3.4 Register Mapping

It is possible to have two independent A/D converters in the same device. In this case they are named A/D 0 and A/D 1. If the device has one A/D converter it uses the register addresses of A/D 0. The register map is the following:

Register Address	ADn	Page 62 (3Eh)
F0h	A/D 0	ADDTR0
F1h	A/D 0	ADCLR0
F2h	A/D 0	ADINT0
F3-F7h	A/D 0	Reserved
F8h	A/D 1	ADDTR1
F9h	A/D 1	ADCLR1
FAh	A/D 1	ADINT1
FB-FFh	A/D 1	Reserved

If two A/D converters are present, the registers are renamed, adding the suffix 0 to the A/D 0 registers and 1 to the A/D 1 registers.

A/D CONVERTER (Cont'd)

8.6.4 Register Description

A/D CONTROL LOGIC REGISTER (ADCLR)

R241 - Read/Write

Register Page: 62

Reset value: 0000 0000 (00h)

7							0
C2	C1	C0	FS	TRG	POW	CONT	STR

This 8-bit register manages the A/D logic operations. Any write operation to it will cause the current conversion to be aborted and the logic to be re-initialized to the starting configuration.

Bit 7:5 = **C[2:0]**: *Channel Address*.

These bits are set and cleared by software. They select channel *i* conversion as follows:

C2	C1	C0	Channel Enabled
0	0	0	Channel 0
0	0	1	Channel 1
0	1	0	Channel 2
0	1	1	Channel 3
1	0	0	Channel 4
1	0	1	Channel 5
1	1	0	Channel 6
1	1	1	Channel 7

Bit 4 = **FS**: *Fast/Slow*.

This bit is set and cleared by software.

0: Fast mode. Single conversion time: $78 \times \text{INTCLK}$ ($5.75\mu\text{s}$ at $\text{INTCLK} = 12 \text{ MHz}$)

1: Slow mode. Single conversion time: $138 \times \text{INTCLK}$ ($11.5\mu\text{s}$ at $\text{INTCLK} = 12 \text{ MHz}$)

Note: Fast conversion mode is only allowed for internal speeds which do not exceed 12 MHz.

Bit 3 = **TRG**: *External/Internal Trigger Enable*.

This bit is set and cleared by software.

0: External/Internal Trigger disabled.

1: Either a negative (falling) edge on the EXTRG pin or an On Chip Event writes a "1" into the STR bit, enabling start of conversion.

Note: Triggering by on chip event is available on devices with the multifunction timer (MFT) peripheral.

Bit 2 = **POW**: *Power Enable*.

This bit is set and cleared by software.

0: Disables all power consuming logic.

1: Enables the A/D logic and analog circuitry.

Bit 1 = **CONT**: *Continuous/Single Mode Select*.

This bit is set and cleared by software.

0: Single mode: after the current conversion ends, the STR bit is reset by hardware and the converter logic is put in a wait status. To start another conversion, the STR bit has to be set by software or hardware.

1: Select Continuous Mode, a continuous flow of A/D conversions on the selected channel, starting when the STR bit is set.

Bit 0 = **STR**: *Start/Stop*.

This bit is set and cleared by software. It is also set by hardware when the A/D is synchronized with an external/internal trigger.

0: Stop conversion on channel *i*. An interrupt is generated if the STR was previously set and the AD-INT bit is set.

1: Start conversion on channel *i*

WARNING: When accessing this register, it is recommended to keep the related A/D interrupt channel masked or disabled to avoid spurious interrupt requests.

A/D CHANNEL *i* DATA REGISTER (ADDTR)

R240 - Read/Write

Register Page: 62

Reset value: undefined

7							0
R.7	R.6	R.5	R.4	R.3	R.2	R.1	R.0

The result of the conversion of the selected channel is stored in the 8-bit ADDTR, which is reloaded with a new value every time a conversion ends.

ST92163 - A/D CONVERTER (A/D)

A/D CONVERTER (Cont'd)

A/D INTERRUPT REGISTER (ADINT)

Register Page: 62

R242 - Read/write

Reset value: 0000 0001 (01h)

7							0
0	0	0	0	0	0	0	AD-INT

Bit 7:1 = Reserved.

Bit 0 = **AD-INT**: *AD Converter Interrupt Enable.*

This bit is set and cleared by software. It allows the interrupt source to be switched between the A/D Converter and an external interrupt pin (See Interrupts chapter).

0: A/D Interrupt disabled. External pin selected as interrupt source.

1: A/D Interrupt enabled

EEPW.com.cn 电子產品世界

9 ELECTRICAL CHARACTERISTICS

The ST92163 device contains circuitry to protect the inputs against damage due to high static voltage or electric field. Nevertheless it is advised to take normal precautions and to avoid applying to this high impedance voltage circuit any voltage higher than the maximum rated voltages. It is recommended for proper operation that V_{IN} and V_{OUT} be constrained to the range:

$$V_{SS} \leq (V_{IN} \text{ or } V_{OUT}) \leq V_{DD}$$

To enhance reliability of operation, it is recommended to connect unused inputs to an appropriate logic voltage level such as V_{SS} or V_{DD} . All the voltages in the following table, are referenced to V_{SS} .

ABSOLUTE MAXIMUM RATINGS

Symbol	Parameter	Value	Unit
V_{DD}	Supply Voltage	- 0.3 to +7.0	V
V_I	Input Voltage	- 0.3 to $V_{DD} + 0.3$	V
V_{AI}	Analog Input Voltage (A/D Converter)	$V_{SS} - 0.3$ to $V_{DD} + 0.3$ $AV_{SS} - 0.3$ to $AV_{DD} + 0.3$	V
V_O	Output Voltage	- 0.3 to $V_{DD} + 0.3$	V
T_{STG}	Storage Temperature	- 55 to + 150	°C
I_{INJ}	Pin Injection Current Digital and Analog Input	-5 to +5	mA
	Maximum Accumulated Pin injection Current in the device	-50 to +50	mA
AV_{DD}	A/D Converter Analog Reference	$V_{DD} - 0.3$ to $V_{DD} + 0.3$	V
AV_{SS}	A/D Converter V_{SS}	$V_{SS} - 0.3$ to $V_{SS} + 0.3$	V

Note: Stresses above those listed as "absolute maximum ratings" may cause permanent damage to the device. This is a stress rating only and functional operation of the device at these conditions is not implied. Exposure to maximum rating conditions for extended periods may affect device reliability. All voltages are referenced to V_{SS} .

RECOMMENDED OPERATING CONDITIONS

(Normal Voltage Mode, all devices)

Symbol	Parameter	Value		Unit
		Min.	Max.	
T_A	Operating Temperature	0	70	°C
V_{DD}	Operating Supply Voltage	4.0	5.5	V
f_{INTCLK}	Internal Clock Frequency @ 4.0V - 5.5V	0 ⁽¹⁾	24	MHz

Note 1. 1MHz when A/D is used

RECOMMENDED OPERATING CONDITIONS

(Low Voltage Modes, devices with suffix L or V)

Symbol	Parameter	Value		Unit	
		Min.	Max.		
T_A	Operating Temperature	0	70	°C	
V_{DD}	Operating Supply Voltage	3.0	4.0	V	
f_{INTCLK}	Internal Clock Frequency @ 3.0V - 4.0V	8-MHz Low Voltage devices (devices with suffix L)	0 ⁽¹⁾	8	MHz
		16-MHz Low Voltage devices (devices with suffix V)	0 ⁽¹⁾	16	MHz

Note 1. 1MHz when A/D is used

ST92163 - ELECTRICAL CHARACTERISTICS

DC ELECTRICAL CHARACTERISTICS

($V_{DD} = 4.0 - 5.5V$, $T_A = 0^{\circ}C + 70^{\circ}C$, unless otherwise specified)

Symbol	Parameter	Test Conditions	Value			Unit
			Min.	Typ.	Max.	
V_{IHCK}^*	Clock Input High Level	External Clock	$0.7 V_{DD}$		$V_{DD} + 0.3$	V
V_{ILCK}^*	Clock Input Low Level	External Clock	- 0.3		$0.3 V_{DD}$	V
V_{IH}^*	Input High Level	TTL	2.0		$V_{DD} + 0.3$	V
		CMOS	$0.7 V_{DD}$		$V_{DD} + 0.3$	V
V_{IL}^*	Input Low Level	TTL	- 0.3		0.8	V
		CMOS	- 0.3		$0.3 V_{DD}$	V
V_{IHRS}^*	\overline{RESET} Input High Level		$0.7 V_{DD}$		$V_{DD} + 0.3$	V
V_{ILRS}^*	\overline{RESET} Input Low Level		-0.3		$0.3 V_{DD}$	V
V_{HYRS}^*	\overline{RESET} Input Hysteresis		0.3		1.5	V
V_{OH}^*	Output High Level	Push Pull, $I_{load} = - 0.8mA$	$V_{DD} - 0.8$			V
V_{OL}	Output Low Level	Push Pull or Open Drain, $I_{load} = 1.6mA$			0.4	V
	Output Low Level high sink pins (Port 6)	$I_{load} = 10mA$			1	V
I_{WPU}	Weak Pull-up Current	Bidirectional Weak Pull-up, $V_{OL} = 0V$	- 40	- 200	- 420	μA
I_{APU}	Active Pull-up Current, for INT0 and INT7 only	$V_{IN} < 0.8V$, under Reset	- 80	- 200	- 420	μA
I_{LKIO}^*	I/O Pin Input Leakage	Input/Tri-State, $0V < V_{IN} < V_{DD}$	- 10		+ 10	μA
I_{LKRS}^*	\overline{RESET} Pin Input Leakage	$0V < V_{IN} < V_{DD}$	- 30		+ 30	μA
$I_{LKA/D}^*$	A/D Conv. Input Leakage		- 3		+ 3	μA
I_{LKAP}^*	Active Pull-up Input Leakage	$0V < V_{IN} < 0.8V$	- 10		+ 10	μA
I_{LKOS}^*	OSCIN Pin Input Leakage	$0V < V_{IN} < V_{DD}$			± 3	μA

*For devices with suffix L or V, these characteristics are valid for $V_{DD} = 3.0 - 5.5V$

Note: All I/O Ports are configured in bidirectional weak pull-up mode with no DC load external clock pin (OSCIN) is driven by square wave external clock. No peripheral working.

AC ELECTRICAL CHARACTERISTICS

($V_{DD} = 4.0 - 5.5V$, $T_A = 0^{\circ}C + 70^{\circ}C$, unless otherwise specified)

Symbol	Parameter	$V_{DD} \text{ MAX}$	Unit
I_{DD}	Run Mode Current @ 24 MHz	85 ⁽¹⁾	mA
I_{WFI}	WFI Mode @ 24 MHz	20 ⁽¹⁾	mA
I_{HALT}	HALT Mode Current	100	μA
I_{SUSP}	USB Suspend mode current ⁽²⁾	450	μA

($V_{DD} = 3.0 - 3.3 V$, $T_A = 0^{\circ}C + 70^{\circ}C$)

Symbol	Parameter	V_{DD}		Unit
		TYP	MAX	
I_{DD}	Run Mode Current	1.2	1.4	mA/MHz
I_{WFI}	WFI Mode	0.3	0.4	mA/MHz
I_{HALT}	HALT Mode Current		100	μA

Note: All I/O Ports are configured in bidirectional weak pull-up mode with no DC load, external clock pin (OSCIN) is driven by square wave external clock

⁽¹⁾ Preliminary value

⁽²⁾ External pull-up (1.5 Kohms connected to USBV_{CC}); Operating conditions; $V_{DD} = 4.0 - 5.25V$; $T_A = 25^{\circ}C$

AC TEST CONDITIONS

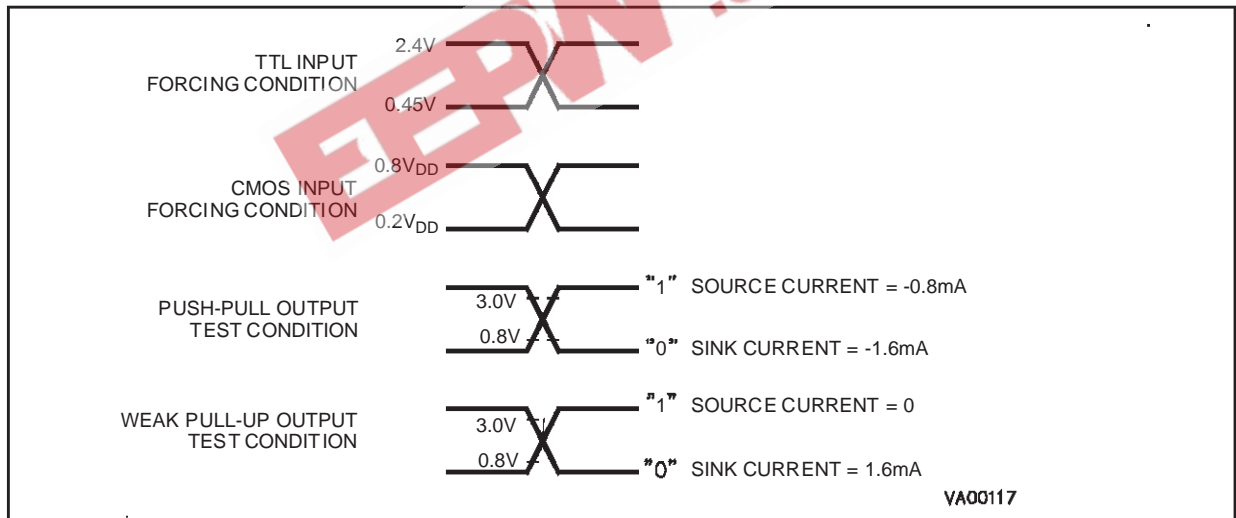

ST92163 - ELECTRICAL CHARACTERISTICS

ELECTRICAL CHARACTERISTICS (Cont'd)

Low Voltage Detector Reset Electrical Specifications*						
Symbol	Parameter	Conditions	Min	Typ	Max	Unit
V_{LVDUP}	LV Reset Trigger V_{DD} rising edge	INTCLK = 16MHz	3.5	3.7	3.9	V
$V_{LVDDOWN}$	LV Reset Trigger V_{DD} Falling edge		3.3	3.5	3.7	V
$V_{LVDHyst}$	Hysteresis **		150	200	250	mV

*Not available on devices with suffix L, V or E

**Guaranteed by design

I ² C Interface Electrical specifications						
Parameter	Symbol	Standard mode I2C		Fast mode I2C		Unit
		Min	Max	Min	Max	
Low level input voltage: fixed input levels V_{DD} -related input levels	V_{IL}	-0.5 -0.5	1.5 $0.3 V_{DD}$	-0.5 -0.5	1.5 $0.3 V_{DD}$	V
High level input voltage: V_{DD} -related input levels		$0.7 V_{DD}$	$V_{DD}+0.5$	$0.7 V_{DD}$	$V_{DD}+0.5$	V
Hysteresis of Schmitt trigger inputs fixed input levels V_{DD} -related input levels	V_{HYS}	N/A N/A	N/A N/A	0.2 $0.05 V_{DD}$		V
Pulse width of spikes which must be suppressed by the input filter	T_{SP}	N/A	N/A	0 ns	50 ns	ns
Low level output voltage (open drain and open collector) at 3 mA sink current at 6 mA sink current	V_{OL1} V_{OL2}	0 N/A	0.4 N/A	0 0	0.4 0.6	V
Output fall time from V_{IH} min to V_{IL} max with a bus capacitance from 10 pF to 400 pF with up to 3 mA sink current at V_{OL1} with up to 6 mA sink current at V_{OL2}	T_{OF}	N/A	250 N/A	$20+0.1C_b$ $20+0.1C_b$	250 250	ns
Input current each I/O pin with an input voltage between 0.4V and $0.9 V_{DD}$ max	I	- 10	10	-10	10	μ A
Capacitance for each I/O pin	C		10		10	pF

N/A = not applicable

ELECTRICAL CHARACTERISTICS (Cont'd)

I ² C Bus Timings						
Parameter	Symbol	Standard I ² C		Fast I ² C		Unit
		Min	Max	Min	Max	
Bus free time between a STOP and START condition	T _{BUF}	4.7		1.3		ms
Hold time START condition. After this period, the first clock pulse is generated	T _{HD:STA}	4.0		0.6		μs
LOW period of the SCL clock	T _{LOW}	4.7		1.3		μs
HIGH period of the SCL clock	T _{HIGH}	4.0		0.6		μs
Set-up time for a repeated START condition	T _{SU:STA}	4.7		0.6		μs
Data hold time	T _{HD:DAT}	0 (1)		0 (1)	0.9(2)	ns
Data set-up time	T _{SU:DAT}	250		100		ns
Rise time of both SDA and SCL signals	T _R		1000	20+0.1Cb	300	ns
Fall time of both SDA and SCL signals	T _F		300	20+0.1Cb	300	ns
Set-up time for STOP condition	T _{SU:STO}	4.0		0.6		ns
Capacitive load for each bus line	C _b		400		400	pF

1)The device must internally provide a hold time of at least 300 ns for the SDA signal in order to bridge the undefined region of the falling edge of SCL

2)The maximum hold time of the START condition has only to be met if the interface does not stretch the low period of SCL signal

C_b = total capacitance of one bus line in pF

ST92163 - ELECTRICAL CHARACTERISTICS

USB INTERFACE: DC CHARACTERISTICS

($V_{DD} = 4.0 - 5.5V$, $T_A = 0^{\circ}C + 70^{\circ}C$, unless otherwise specified)

USB Interface: DC Electrical Characteristics					
Parameter	Symbol	Conditions	Min.	Max.	Unit
Inputs Levels:					
Differential Input Sensitivity	V_{DI}	I(D+, D-)	0.2		V
Differential Common Mode Range	V_{CM}	Includes V_{DI} range	0.8	2.5	V
Single Ended Receiver Threshold	V_{SE}		0.8	2.0	V
Output Levels					
Static Output Low	V_{OL}	RL of 1.5K ohms to 3.6v		0.3	V
Static Output High	V_{OH}	RL of 15K ohm to GND	2.8	3.6	V
USBVCC: voltage level	USB_V	$V_{DD}=5V$	2.97	3.63	V
Hi-Z State Data Line Leakage	I_{LO}	0 V < V_{in} < 3.3 V (Regulator ON)	-10	+10	μA

RL is the load connected on the USB drivers.

All voltages are measured from the local ground potential (USBGND).

EEPW 电子产品世界
.com.cn

ELECTRICAL CHARACTERISTICS (Cont'd)

Figure 87. USB Interface: Data signal rise and fall time

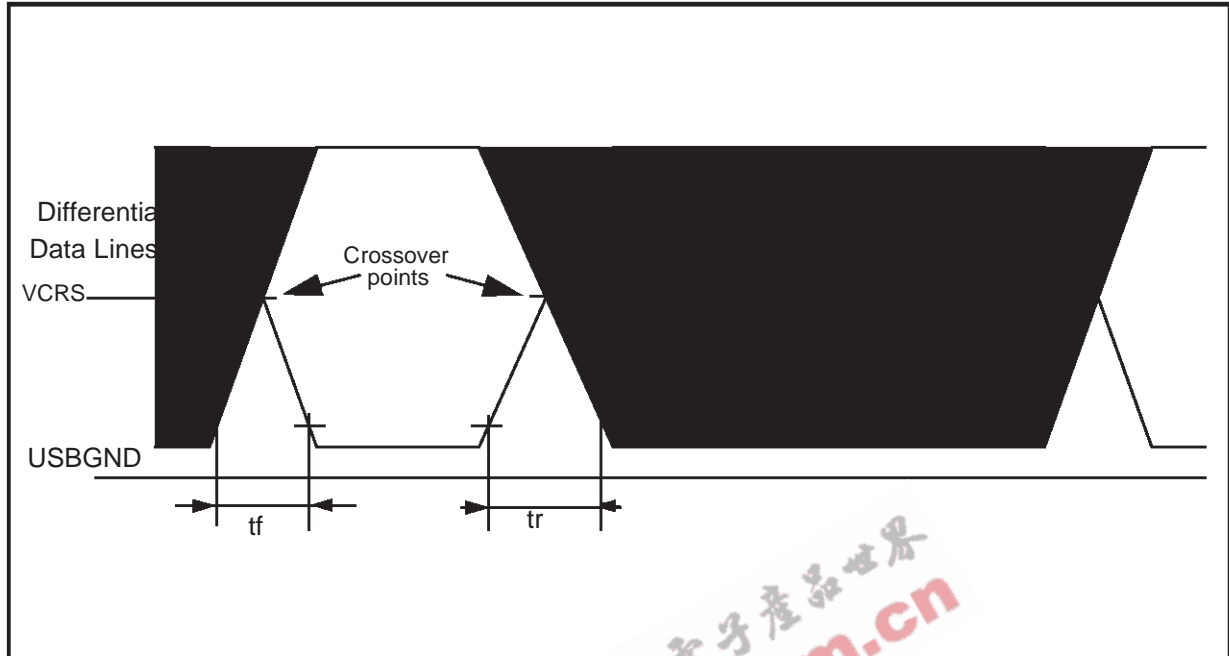

USB INTERFACE: FULL SPEED CHARACTERISTICS

($V_{DD} = 4.0 - 5.5V$, $T_A = 0^{\circ}C + 70^{\circ}C$, unless otherwise specified)

USB Interface: Full speed electrical characteristics					
Parameter	Symbol	Conditions	Min	Max	Unit
Driver characteristics:					
Rise time	t_r	$CL=50\text{ pF}^1$	4	20	ns
Fall Time	t_f	$CL=50\text{ pF}^1$	4	20	ns
Rise/ Fall Time matching	t_{rfm}	t_r/t_f	90	110	%
Output signal Crossover Voltage	VCRS		1.3	2.0	V

¹⁾ Measured from 10% to 90% of the data signal

ST92163 - ELECTRICAL CHARACTERISTICS

EXTERNAL INTERRUPT TIMING TABLE

($V_{DD} = 3.0 - 5.5V$ ⁽¹⁾, $T_A = 0^{\circ}C + 70^{\circ}C$, $C_{Load} = 50pF$, $f_{INTCLK} = 24MHz$, unless otherwise specified)

N°	Symbol	Parameter	Value (Note)			Unit
			Formula ⁽²⁾	Min	Max	
1	TwINTLR	Low Level Pulse Width in Rising Edge Mode	$\geq Tck+10$	50		ns
2	TwINTHR	High Level Pulse Width in Rising Edge Mode	$\geq Tck+10$	50		ns
3	TwINTHF	High Level Pulse Width in Falling Edge Mode	$\geq Tck+10$	50		ns
4	TwINTLF	Low Level Pulse Width in Falling Edge Mode	$\geq Tck+10$	50		ns

Note: The value in the left hand column shows the formula used to calculate the timing minimum or maximum from the oscillator clock period. The value in the right hand two columns show the timing minimum and maximum for an internal clock at 24MHz (INTCLK).

(1) 3.0 - 4.0V voltage range is only available on devices with suffix L or V, with different frequency limitations (L: 8 MHz, V: 16 MHz)

(2) Formula guaranteed by design.

Legend:

Tck = INTCLK period = OSCIN period when OSCIN is not divided by 2;

2 x OSCIN period when OSCIN is divided by 2;

OSCIN period x PLL factor when the PLL is enabled.

EXTERNAL INTERRUPT TIMING

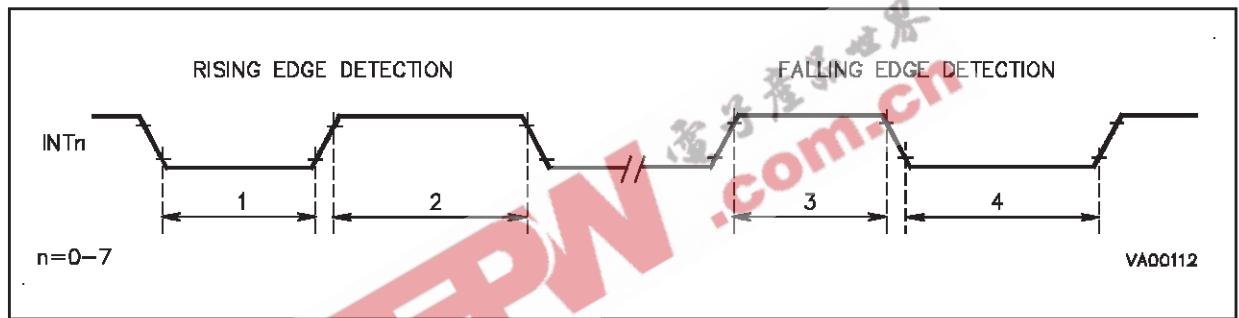

WAKE-UP MANAGEMENT TIMING TABLE

($V_{DD} = 3.0 - 5.5V^{(1)}$, $T_A = 0^{\circ}C + 70^{\circ}C$, $C_{Load} = 50pF$, $f_{INTCLK} = 24MHz$, unless otherwise specified)

N°	Symbol	Parameter	Value (Note)			Unit
			Formula ⁽²⁾	Min	Max	
1	TwWKPLR	Low Level Pulse Width in Rising Edge Mode	$\geq Tck+10$	50		ns
2	TwWKPHR	High Level Pulse Width in Rising Edge Mode	$\geq Tck+10$	50		ns
3	TwWKPHF	High Level Pulse Width in Falling Edge Mode	$\geq Tck+10$	50		ns
4	TwWKPLF	Low Level Pulse Width in Falling Edge Mode	$\geq Tck+10$	50		ns

Note: The value in the left hand column shows the formula used to calculate the timing minimum or maximum from the oscillator clock period. The value in the right hand two columns show the timing minimum and maximum for an internal clock at 24MHz (INTCLK).

The given data are related to Wake-up Management Unit used in External Interrupt mode.

(1) 3.0 - 4.0V voltage range is only available on devices with suffix L or V, with different frequency limitations (L: 8 MHz, V: 16 MHz)

(2) Formula guaranteed by design.

Legend:

- Tck = INTCLK period = OSCIN period when OSCIN is not divided by 2;
- 2 x OSCIN period when OSCIN is divided by 2;
- OSCIN period x PLL factor when the PLL is enabled.

WAKE-UP MANAGEMENT TIMING

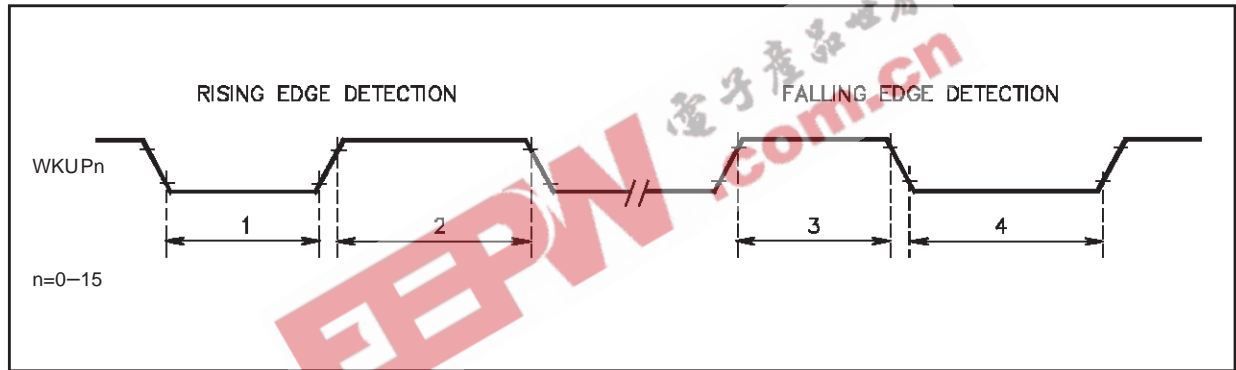

ST92163 - ELECTRICAL CHARACTERISTICS

RCCU CHARACTERISTICS

($V_{DD} = 3.0 - 5.5V$ ⁽¹⁾, $T_A = 0^{\circ}C + 70^{\circ}C$, $C_{Load} = 50pF$, $f_{INTCLK} = 24MHz$, unless otherwise specified)

Symbol	Parameter	Comment	Value (Note)			Unit
			Min	Typ	Max	
V_{IHRS}	\overline{RESET} Input High Level		$0.7 \times V_{DD}$		$V_{DD} + 0.3$	V
V_{ILRS}	\overline{RESET} Input Low Level		- 0.3		$0.3 \times V_{DD}$	V
V_{HYRS}	\overline{RESET} Input Hysteresis		0.3	0.9	1.5	V
I_{LKRS}	\overline{RESET} Pin Input Leakage	$0V < V_{IN} < V_{DD}$	- 1		+ 1	μA

(1) 3.0 - 4.0V voltage range is only available on devices with suffix L or V, with different frequency limitations (L: 8 MHz, V: 16 MHz)

RCCU TIMING TABLE

($V_{DD} = 3.0 - 5.5V$ ⁽¹⁾, $T_A = 0^{\circ}C + 70^{\circ}C$, $C_{Load} = 50pF$, $f_{INTCLK} = 24MHz$, unless otherwise specified)

Symbol	Parameter	Comment	Value (Note)			Unit
			Min	Typ	Max	
T_{FRS}	\overline{RESET} Input Filtered Pulse		50		20	ns μs
T_{RSPH} ⁽²⁾	\overline{RESET} Phase duration			$20400 \times T_{OSC}$		μs
T_{STR}	STOP Restart duration	DIV2 = 0 DIV2 = 1		$10200 \times T_{OSC}$ $20400 \times T_{OSC}$		μs

(1) 3.0 - 4.0V voltage range is only available on devices with suffix L or V, with different frequency limitations (L: 8 MHz, V: 16 MHz)

(2) Depending on the delay between rising edge of \overline{RESETN} pin and the first rising edge of CLOCK1, the value can differ from the typical value for +/- 1 CLOCK1 cycle.

Legend: T_{OSC} = OSCIN clock cycles

PLL CHARACTERISTICS

($V_{DD} = 3.0 - 5.5V$ ⁽¹⁾, $T_A = 0^{\circ}C + 70^{\circ}C$, $C_{Load} = 50pF$, $f_{INTCLK} = 24MHz$, unless otherwise specified)

Symbol	Parameter	Comment	Value (Note)			Unit
			Min	Typ	Max	
F_{XTL}	Crystal Reference Frequency		3		8	MHz
F_{VCO}	VCO Operating Frequency		9		48	MHz
T_{PLK}	Lock-in Time				$1000 \times T_{OSC}$	μs
	PLL Jitter		0		850 ⁽²⁾	ps

(1) 3.0 - 4.0V voltage range is only available on devices with suffix L or V, with different frequency limitations (L: 8 MHz, V: 16 MHz)

(2) Measured at 24MHz (INTCLK). Guaranteed by Design Characterisation (not tested).

Legend: T_{OSC} = OSCIN clock cycles

OSCILLATOR CHARACTERISTICS

($V_{DD} = 3.0 - 5.5V$ ⁽¹⁾, $T_A = 0^{\circ}C + 70^{\circ}C$, $C_{Load} = 50pF$, $f_{INTCLK} = 24MHz$, unless otherwise specified)

Symbol	Parameter	Comment	Value (Note)			Unit
			Min	Typ	Max	
F _{OSC}	Crystal Frequency	Fundamental mode crystal only	3		8	MHz
g _m	Oscillator	V _{DD} = 4.0 - 5.5 V	0.77	1.5	2.4	mA/V
		V _{DD} = 3.0 - 4.0 V	0.5	0.73	1.47	mA/V
V _{IHCK}	Clock Input High Level	External Clock	0.8 x V _{DD}		V _{DD} + 0.3	V
V _{ILCK}	Clock Input Low Level	External Clock	- 0.3		0.2 x V _{DD}	V
I _{LKOS}	OSCIN/OSCOUT Pin Input Leakage	0V < V _{IN} < V _{DD} (HALT/STOP)	- 1		+ 1	μA
T _{STUP}	Oscillator Start-up Time	V _{DD} = 4.0 - 5.5 V			5	ms
		V _{DD} = 3.0 - 4.0 V			20	ms

(1) 3.0 - 4.0V voltage range is only available on devices with suffix L or V, with different frequency limitations (L: 8 MHz, V: 16 MHz)



ST92163 - ELECTRICAL CHARACTERISTICS

EXTERNAL BUS TIMING TABLE

($V_{DD} = 3.0 - 5.5V$ ⁽¹⁾, $T_A = 0^{\circ}C + 70^{\circ}C$, $C_{Load} = 50pF$, $f_{INTCLK} = 24MHz$, unless otherwise specified)

N°	Symbol	Parameter	Value (Note)			Unit
			Formula	Min	Max	
1	TsA (AS)	Address Set-up Time before \overline{AS} ↑	$T_{ck} \times Wa + T_{ckH} - 9$	12		ns
2	ThAS (A)	Address Hold Time after \overline{AS} ↑	$T_{ckL} - 4$	17		ns
3	TdAS (DR)	\overline{AS} ↑ to Data Available (read)	$T_{ck} \times (Wd + 1) + 3$		45	ns
4	TwAS	\overline{AS} Low Pulse Width	$T_{ck} \times Wa + T_{ckH} - 5$	16		ns
5	TdAz (DS)	Address Float to \overline{DS} ↓	0	0		ns
6	TwDS	\overline{DS} Low Pulse Width	$T_{ck} \times Wd + T_{ckH} - 5$	16		ns
7	TdDSR (DR)	\overline{DS} ↓ to Data Valid Delay (read)	$T_{ck} \times Wd + T_{ckH} + 4$		25	ns
8	ThDR (DS)	Data to \overline{DS} ↑ Hold Time (read)	7	7		ns
9	TdDS (A)	\overline{DS} ↑ to Address Active Delay	$T_{ckL} + 11$	32		ns
10	TdDS (AS)	\overline{DS} ↑ to \overline{AS} ↓ Delay	$T_{ckL} - 4$	17		ns
11	TsR/W (AS)	\overline{RW} Set-up Time before ASN ↑	$T_{ck} \times Wa + T_{ckH} - 17$	4		ns
12	TdDSR (R/W)	\overline{DS} ↑ to \overline{RW} and Address Not Valid Delay	$T_{ckL} - 1$	20		ns
13	TdDW (DSW)	Write Data Valid to \overline{DS} ↓ Delay	-16	-16		ns
14	TsD(DSW)	Write Data Set-up before \overline{DS} ↑	$T_{ck} \times Wd + T_{ckH} - 16$	5		ns
15	ThDS (DW)	Data Hold Time after \overline{DS} ↑ (write)	$T_{ckL} - 3$	18		ns
16	TdA (DR)	Address Valid to Data Valid Delay (read)	$T_{ck} \times (Wa + Wd + 1) + T_{ckH} - 7$		55	ns
17	TdAs (DS)	\overline{AS} ↑ to \overline{DS} ↓ Delay	$T_{ckL} - 6$	15		ns

Note: The value in the left hand column shows the formula used to calculate the timing minimum or maximum from the oscillator clock period, prescaler value and number of wait cycles inserted.
The values in the right hand two columns show the timing minimum and maximum for an external clock at 24MHz, prescaler value of zero and zero wait states.

(1) 3.0 - 4.0V voltage range is only available on devices with suffix L or V, with different frequency limitations (L: 8 MHz, V: 16 MHz)

Legend:

T_{ck} = INTCLK period = OSCIN period when OSCIN is not divided by 2;

2 x OSCIN period when OSCIN is divided by 2;

OSCIN period x PLL factor when the PLL is enabled.

T_{ckH} = INTCLK high pulse width (normally = $T_{ck}/2$, except when INTCLK = OSCIN, in which case it is OSCIN high pulse width)

T_{ckL} = INTCLK low pulse width (normally = $T_{ck}/2$, except when INTCLK = OSCIN, in which case it is OSCIN low pulse width)

P = clock prescaling value (=PRS; division factor = 1+P)

Wa = wait cycles on \overline{AS} ; = max (P, programmed wait cycles in EMR2, requested wait cycles with \overline{WAIT})

Wd = wait cycles on \overline{DS} ; = max (P, programmed wait cycles in WCR, requested wait cycles with \overline{WAIT})

EXTERNAL BUS TIMING

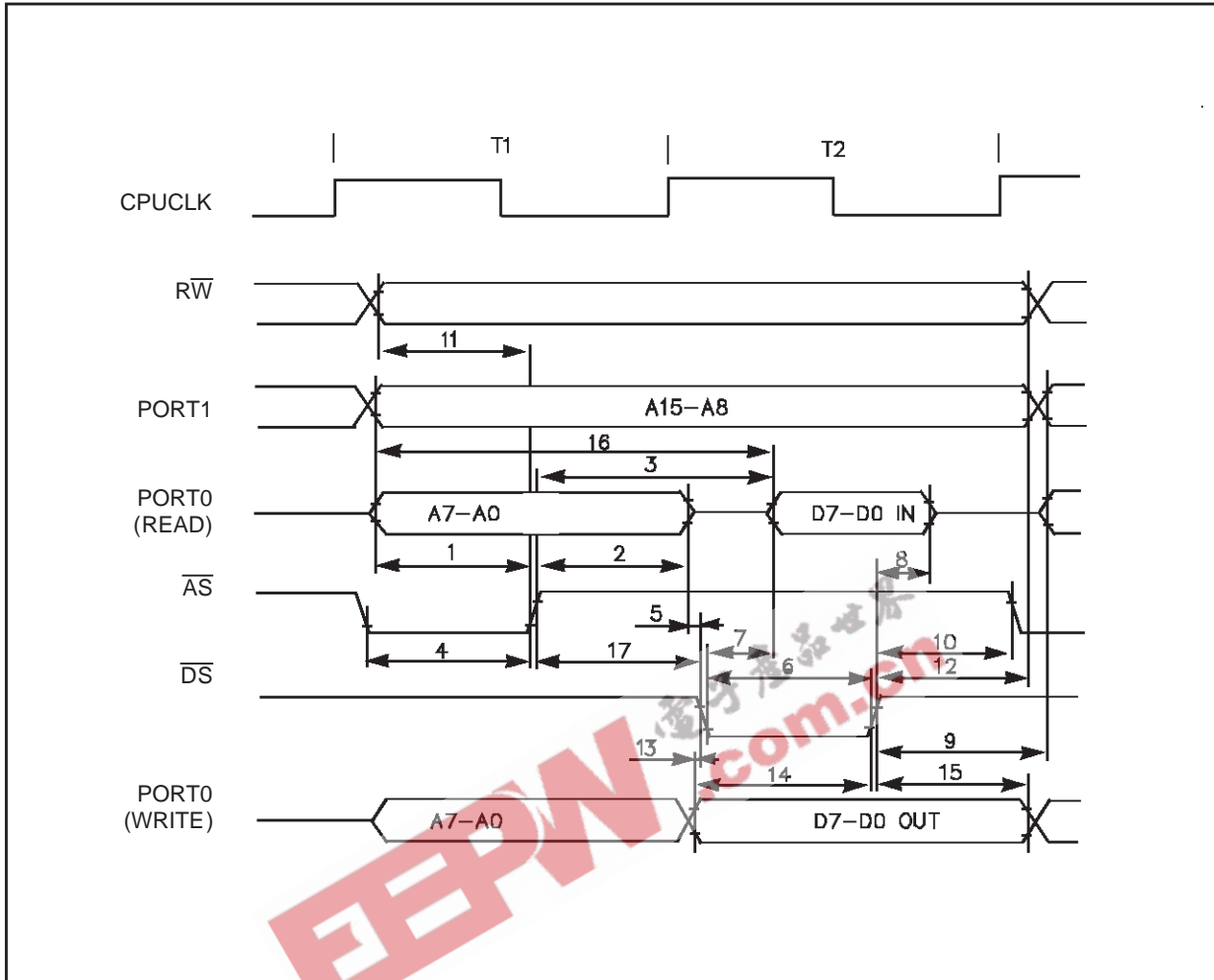

ST92163 - ELECTRICAL CHARACTERISTICS

WATCHDOG TIMING TABLE

($V_{DD} = 3.0 - 5.5V^{(1)}$, $T_A = 0^{\circ}C + 70^{\circ}C$, $C_{Load} = 50pF$, $f_{INTCLK} = 24MHz$, Push-pull output configuration, unless otherwise specified)

N°	Symbol	Parameter	Value (Note)			Unit
			Formula	Min	Max	
1	TwWDOL	WDOOUT Low Pulse Width	$4 \times (Psc+1) \times (Cnt+1) \times Tck$	167	2.8	ns s
			$(Psc+1) \times (Cnt+1) \times T_{WDIN}$ with $T_{WDIN} \geq 8 \times Tck$	333		ns
2	TwWDOH	WDOOUT High Pulse Width	$4 \times (Psc+1) \times (Cnt+1) \times Tck$	167	2.8	ns s
			$(Psc+1) \times (Cnt+1) \times T_{WDIN}$ with $T_{WDIN} \geq 8 \times Tck$	333		ns
3	TwWDIL	WDIN High Pulse Width	$\geq 4 \times Tck$	167		ns
4	TwWDIH	WDIN Low Pulse Width	$\geq 4 \times Tck$	167		ns

Note: The value in the left hand column shows the formula used to calculate the timing minimum or maximum from the oscillator clock period, watchdog prescaler and counter programmed values. The value in the right hand two columns show the timing minimum and maximum for an internal clock (INTCLK) at 24MHz, with minimum and maximum prescaler value and minimum and maximum counter value.

(1) 3.0 - 4.0V voltage range is only available on devices with suffix L or V, with different frequency limitations (L: 8 MHz, V: 16 MHz)

Legend:

$Tck = INTCLK$ period = OSCIN period when OSCIN is not divided by 2;

2 x OSCIN period when OSCIN is divided by 2;

OSCIN period x PLL factor when the PLL is enabled.

Psc = Watchdog Prescaler Register content (WDTPR): from 0 to 255

Cnt = Watchdog Counter Registers content (WDTRH,WDTRL): from 0 to 65535

T_{WDIN} = Watchdog Input signal period (WDIN)

WATCHDOG TIMING

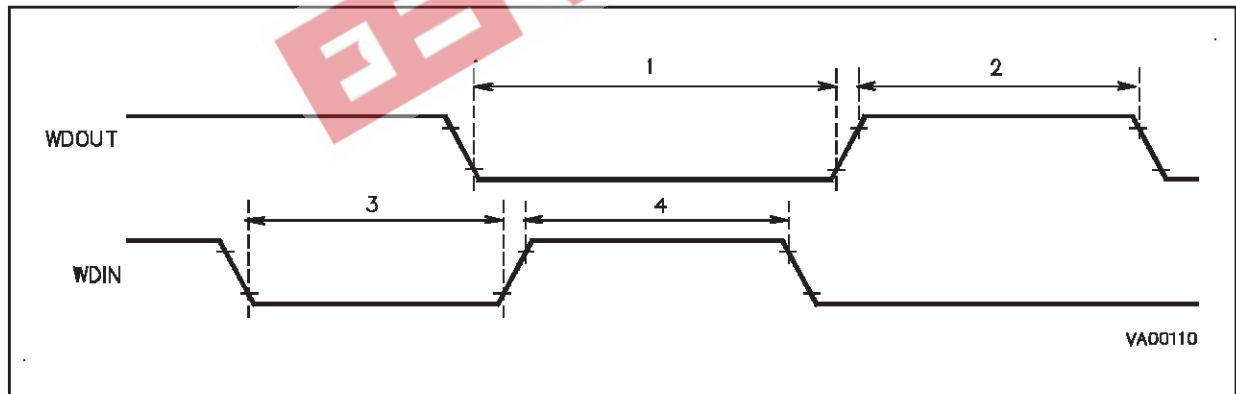

MULTIFUNCTION TIMER EXTERNAL TIMING TABLE

($V_{DD} = 3.0 - 5.5V$ ⁽¹⁾, $T_A = 0^{\circ}C + 70^{\circ}C$, $C_{Load} = 50pF$, $f_{INTCLK} = 24MHz$, unless otherwise specified)

N°	Symbol	Parameter	Value			Unit	Note
			Formula	Min	Max		
1	T_{WCTW}	External clock/trigger pulse width	$n \times Tck$	$n \times 42$	-	ns	(2)
2	T_{WCTD}	External clock/trigger pulse distance	$n \times Tck$	$n \times 42$	-	ns	(2)
3	T_{WAED}	Distance between two active edges	$3 \times Tck$	125	-	ns	
4	T_{WGW}	Gate pulse width	$6 \times Tck$	250	-	ns	
5	T_{WLBA}	Distance between TINB pulse edge and the following TINA pulse edge	Tck	42	-	ns	(3)
6	T_{WLAB}	Distance between TINA pulse edge and the following TINB pulse edge		0	-	ns	(3)
7	T_{WAD}	Distance between two TxINA pulses		0	-	ns	(3)
8	T_{WOWD}	Minimum output pulse width/distance	$3 \times Tck$	125	-	ns	

Note: The value in the left hand column shows the formula used to calculate the timing minimum or maximum from the oscillator clock period, standard timer prescaler and counter programmed values.

The value in the right hand two columns show the timing minimum and maximum for an internal clock (INTCLK) at 24MHz.

(1) 3.0 - 4.0V voltage range is only available on devices with suffix L or V, with different frequency limitations (L: 8 MHz, V: 16 MHz)

(2) $n = 1$ if the input is rising OR falling edge sensitive

$n = 3$ if the input is rising AND falling edge sensitive

(3) In Autodiscrimination mode

Legend:

$Tck = INTCLK$ period = OSCIN period when OSCIN is not divided by 2;

$2 \times OSCIN$ period when OSCIN is divided by 2;

OSCIN period \times PLL factor when the PLL is enabled.

MULTIFUNCTION TIMER EXTERNAL TIMING

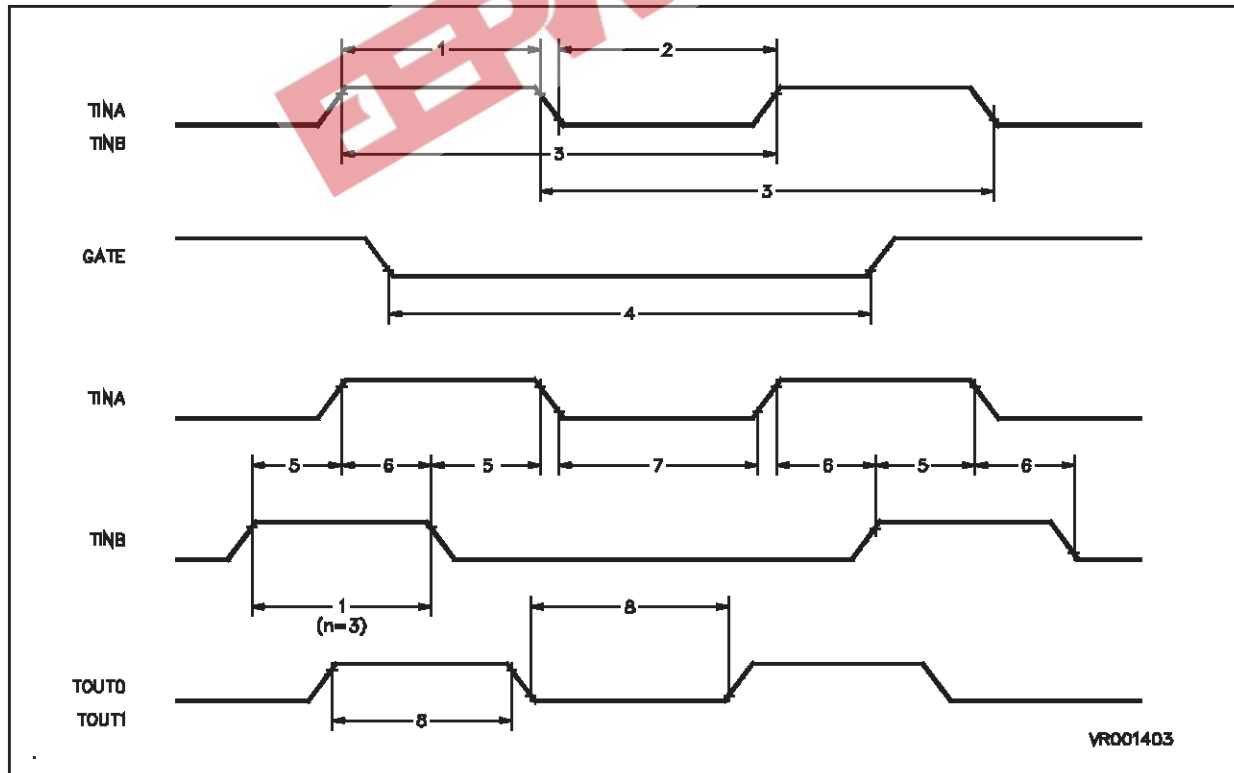

ST92163 - ELECTRICAL CHARACTERISTICS

SCI TIMING TABLE

($V_{DD} = 3.0 - 5.5V$ ⁽¹⁾, $T_A = 0^\circ C + 70^\circ C$, $C_{Load} = 50pF$, $f_{INTCLK} = 24MHz$, unless otherwise specified)

N°	Symbol	Parameter	Condition	Value		Unit
				Min	Max	
	F _{RxCKIN}	Frequency of RxCKIN	1x mode		$f_{INTCLK} / 8$	MHz
			16x mode		$f_{INTCLK} / 4$	MHz
	T _{WRxCKIN}	RxCKIN shortest pulse	1x mode	4 x Tck		s
			16x mode	2 x Tck		s
	F _{TxCKIN}	Frequency of TxCKIN	1x mode		$f_{INTCLK} / 8$	MHz
			16x mode		$f_{INTCLK} / 4$	MHz
T _{WTxCKIN}	TxCKIN shortest pulse	1x mode	4 x Tck		s	
		16x mode	2 x Tck		s	
1	T _{sDS}	DS (Data Stable) before rising edge of RxCKIN	1x mode reception with RxCKIN	Tck / 2		ns
2	T _{dD1}	TxCKIN to Data out delay Time	1x mode transmission with external clock $C_{Load} < 50pF$		2.5 x Tck	ns
3	T _{dD2}	CLKOUT to Data out delay Time	1x mode transmission with CLKOUT	TBD		ns

(1) 3.0 - 4.0V voltage range is only available on devices with suffix L or V, with different frequency limitations (L: 8 MHz, V: 16 MHz)

Legend:

Tck = INTCLK period = OSCIN period when OSCIN is not divided by 2;
 2 x OSCIN period when OSCIN is divided by 2;
 OSCIN period x PLL factor when the PLL is enabled.

SCI TIMING

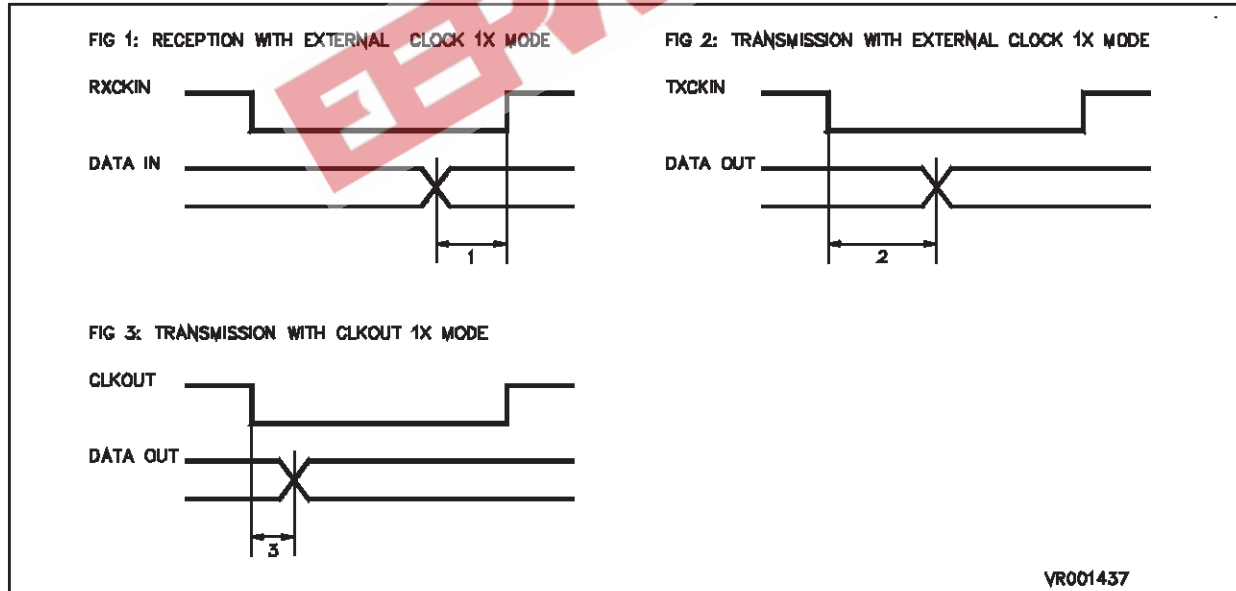

ST92163 - ELECTRICAL CHARACTERISTICS

A/D CONVERTER, EXTERNAL TRIGGER TIMING TABLE

($V_{DD}= 3.0 - 5.5V$ ⁽¹⁾; $T_A= 0$ to $70^{\circ}C$; unless otherwise specified)

Symbol	Parameter	OSCIN divide by 2; min/max	OSCIN divide by 1; min/max	Value		Unit
				min	max	
T_{low}	Pulse Width			1.5 INTCLK		ns
T_{high}	Pulse Distance					ns
T_{ext}	Period/fast Mode			78+1 INTCLK		μs
T_{str}	Start Conversion Delay			0.5	1.5	INTCLK
Core Clock issued by Timing Controller						
T_{low}	Pulse Width					ns
T_{high}	Pulse Distance					ns
T_{ext}	Period/fast Mode					μs
T_{str}	Start Conversion Delay					ns

(1) 3.0 - 4.0V voltage range is only available on devices with suffix L or V, with different frequency limitations (L: 8 MHz, V: 16 MHz)

A/D CONVERTER, ANALOG PARAMETERS TABLE

($V_{DD}= 3.0 - 5.5V$ ⁽¹⁾; $T_A= 0$ to $70^{\circ}C$; unless otherwise specified)

Parameter	Value			Unit (**)	Note
	typ (*)	min	max		
Analog Input Range		V_{SS}	V_{DD}	V	
Conversion Time Fast/Slow		78/138		INTCLK	(2)
Sample Time Fast/Slow		51.5/87.5		INTCLK	
Power-up Time		60		μs	
Resolution	8			bits	
Differential Non Linearity	0.5		1.5	LSBs	(4)
Integral Non Linearity	0.5		1.5	LSBs	(4)
Offset Error	0.5		1		
Gain Error	0.5		1.5		
Absolute Accuracy	1		2	LSBs	(4)
Input Resistance			1.5	Kohm	(3)
Hold Capacitance			1.92	pF	

Notes: (*) The values are expected at 25 Celsius degrees with $V_{DD}= 5V$

(**) 'LSBs', as used here, as a value of $V_{DD}/256$

(1) 3.0 - 4.0V voltage range is only available on devices with suffix L or V, with different frequency limitations (L: 8 MHz, V: 16 MHz)

(2) including Sample time

(3) it must be considered as the on-chip series resistance before the sampling capacitor

(4) $DNL\ ERROR = \max \{ [V(i) - V(i-1)] / LSB - 1 \}$ $INL\ ERROR = \max \{ [V(i) - V(0)] / LSB - i \}$

ABSOLUTE ACCURACY= overall max conversion error

10 GENERAL INFORMATION

10.1 EPROM/OTP PROGRAMMING

The 20 Kbytes of EPROM/OTP of the ST92E163/ST92T163 may be programmed using the EPROM programming boards available from STMicroelectronics.

EPROM Erasing

The EPROM of the windowed package of the ST92E163 can be erased by exposure to Ultra-Violet light.

The erasure characteristic of the ST92E163 is such that erasure begins when the memory is exposed to light with wave lengths shorter than approximately 4000Å. It should be noted that sunlight and some types of fluorescent lamps have wave-lengths in the range 3000-4000Å. It is recom-

mended to cover the window of the ST92E163 packages by an opaque label to prevent unintentional erasure problems when testing the application in such an environment.

The recommended erasure procedure of the EPROM is the exposure to short wave ultraviolet light which have a wave-length 2537Å. The integrated dose (i.e. U.V. intensity x exposure time) for erasure should be a minimum of 15W-sec/cm². The erasure time with this dosage is approximately 30 minutes using an ultraviolet lamp with a 12000 mW/cm² power rating. The device should be placed within 2.5 cm (1 inch) of the lamp tubes during erasure.

EEPW 电子产品世界
.com.cn

10.2 PACKAGE DESCRIPTION

Figure 88. 56-Pin Shrink Plastic Dual In Line Package, 600-mil Width

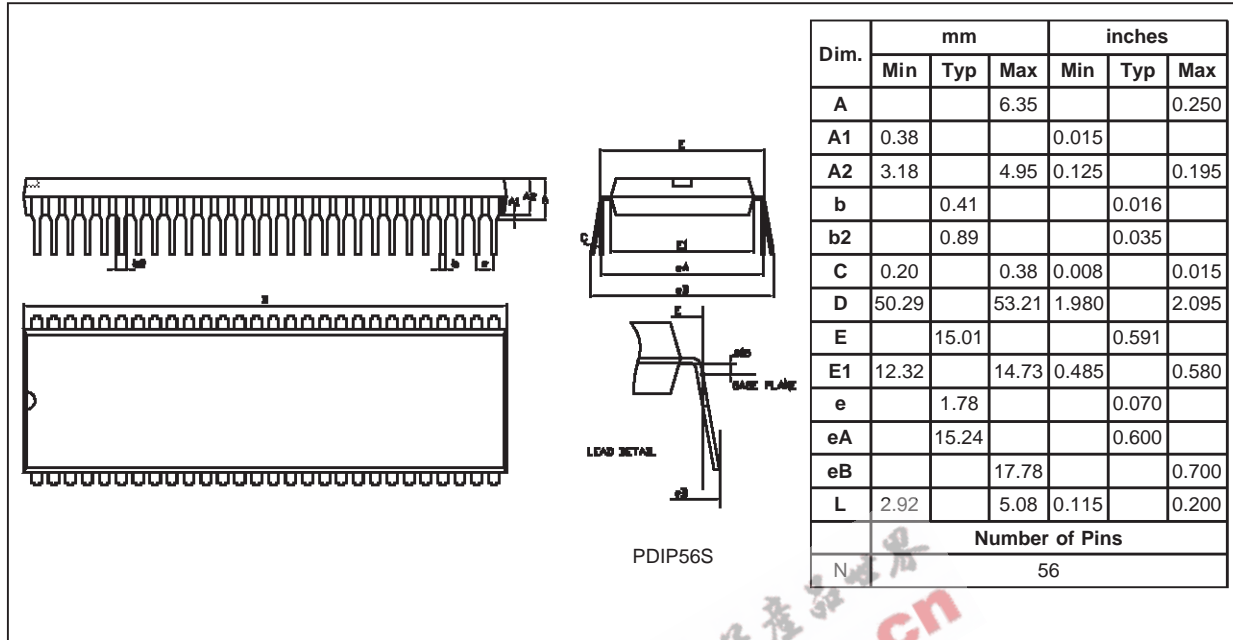
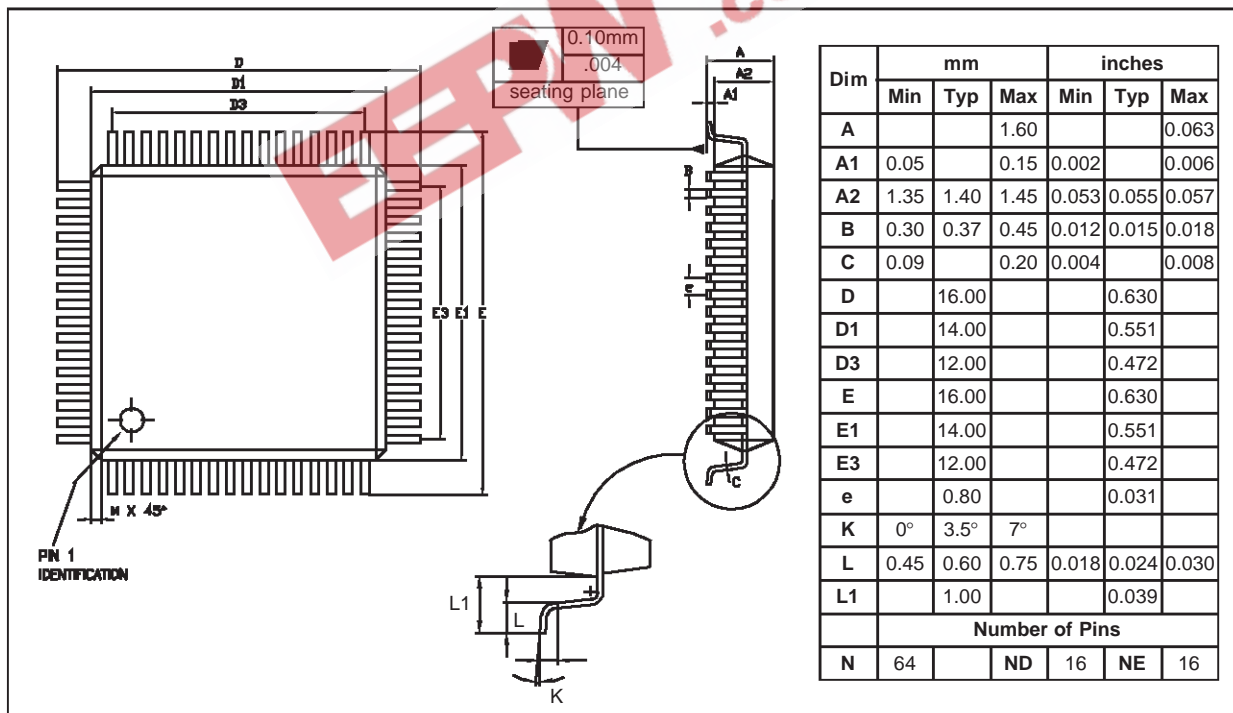

Figure 89. 64-Pin Thin Quad Flat Package



ST92163 - GENERAL INFORMATION

PACKAGE DESCRIPTION (Cont'd)

Figure 90. 56-Pin Shrink Ceramic Dual In-Line Package, 600-mil Width

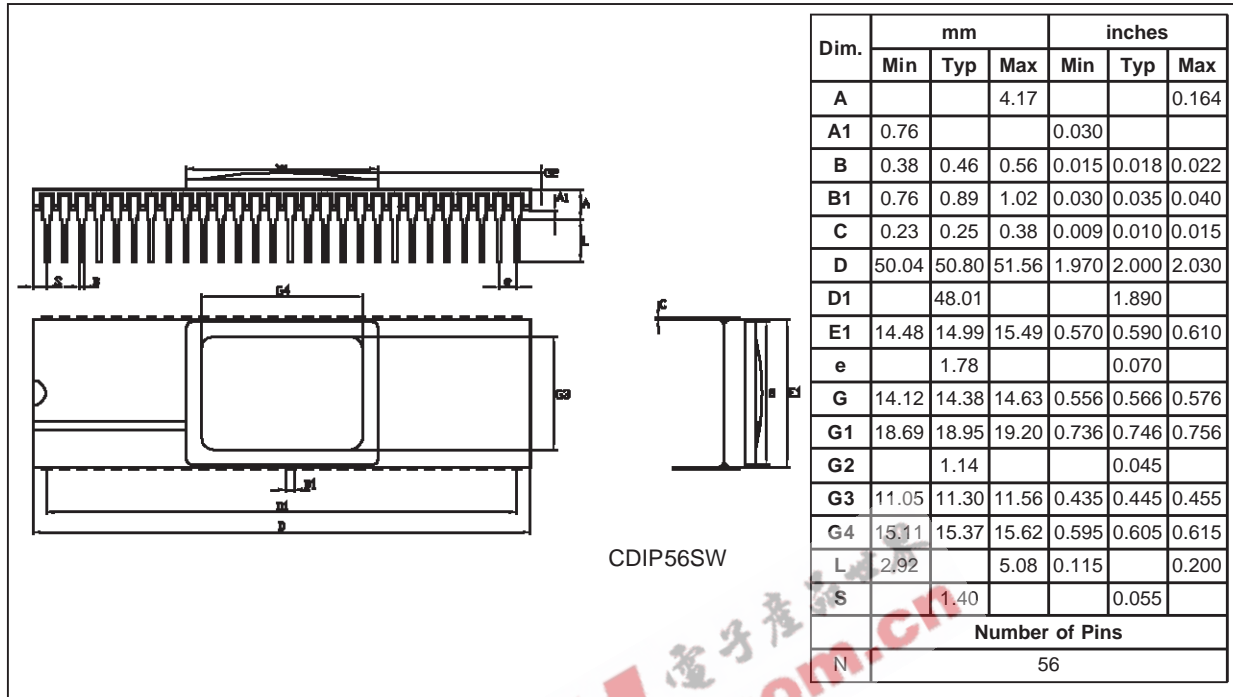
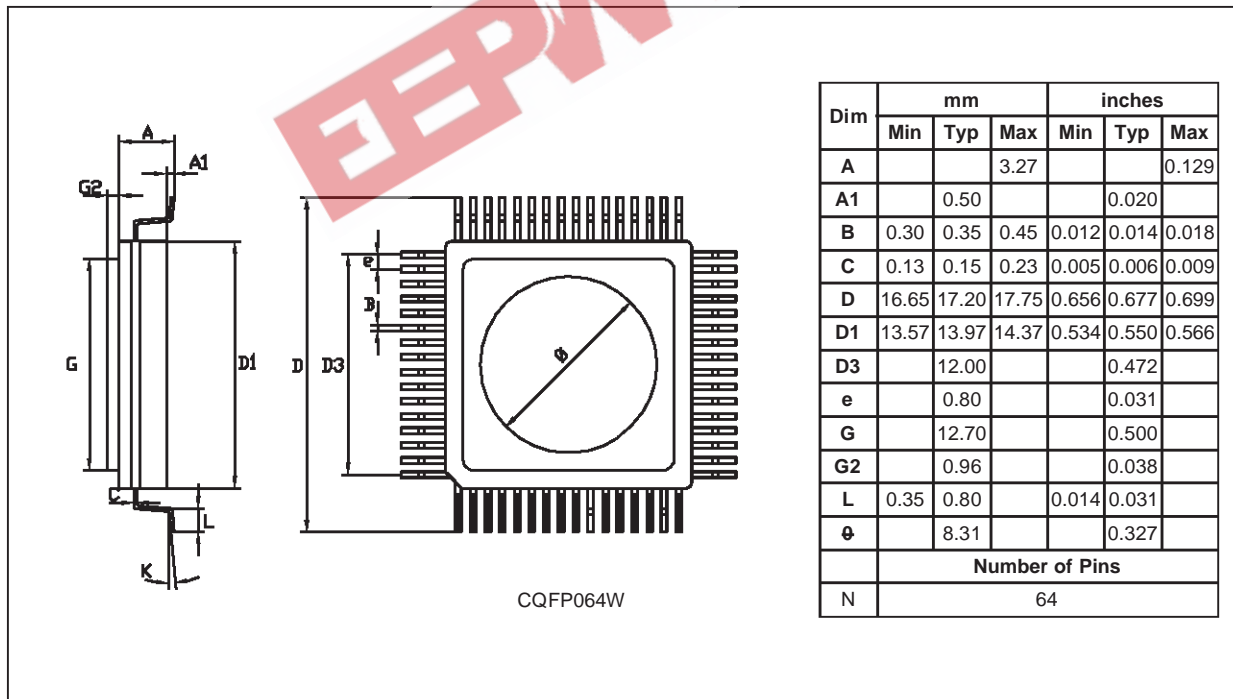

Figure 91. 64-Pin Ceramic Quad Flat Package



10.3 ORDERING INFORMATION

The following section deals with the procedure for transfer of customer codes to STMicroelectronics.

10.4 Transfer of Customer Code

Customer code is made up of the ROM contents. The ROM contents are to be sent on diskette, or by electronic means, with the hexadecimal file

generated by the development tool. All unused bytes must be set to FFh.

The customer code should be communicated to STMicroelectronics with the correctly completed OPTION LIST appended.

The STMicroelectronics Sales Organization will be pleased to provide detailed information on contractual points.

Figure 92. Sales Type Coding Rules

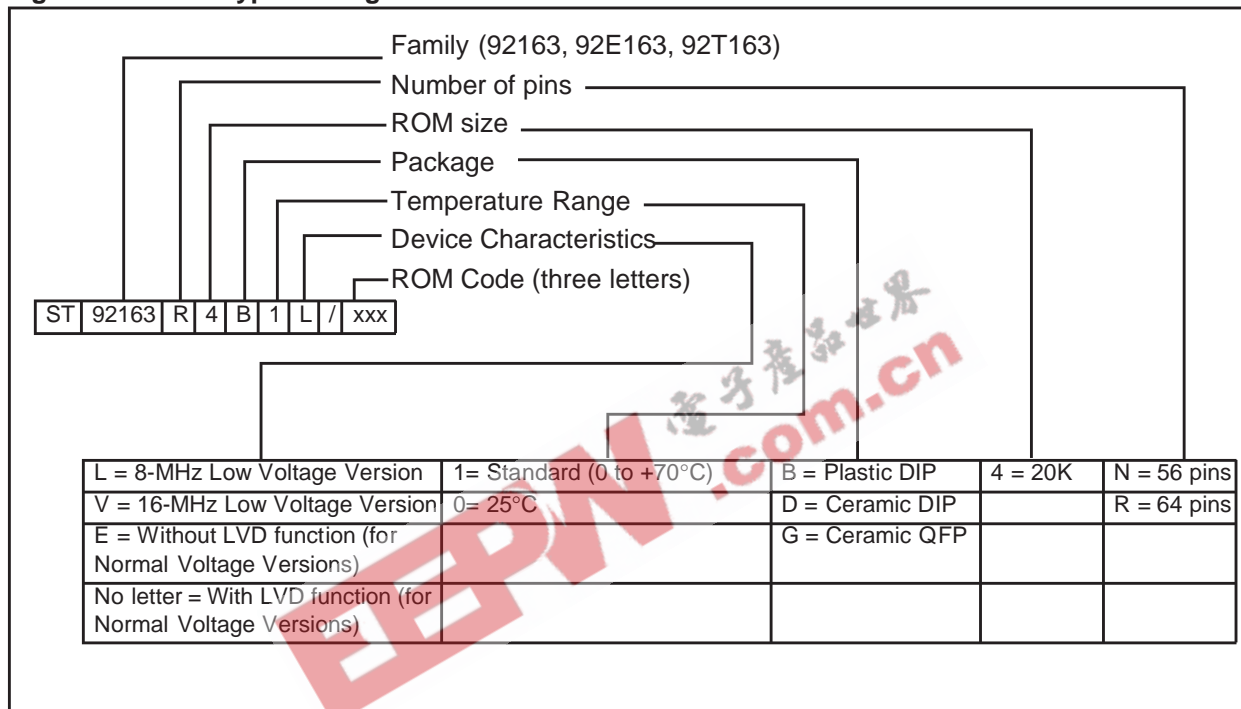

Table 37. Development Tools

Development Tool	Sales Type	Remarks
Real time emulator ¹	ST92163-EMU2	
EPROM Programming Board	ST92E163-EPB/EU	220V Power Supply
	ST92E163-EPB/US	110V Power Supply
Gang Programmer	ST92E16x-GP/DIP56	SDIP56 package
	ST92E16x-GP/QFP	TQFP64 package
C Hiware Compiler and Debugger	ST9P-SWC/V4	for PC

Note 1: The emulator does not support Low Voltage Modes

ST92163 - GENERAL INFORMATION

Table 38. Ordering Information

Sales Type ¹⁾	Program Memory (bytes)	Mode	Operating Voltage		Package	
ST92163N4B1/xxx ²⁾	20K ROM	Normal	4.0-5.5 V		PSDIP56	
ST92163R4T1/xxx ²⁾			4.0-5.5 V		TQFP64	
ST92E163N4D0	20K EPROM		4.0-5.5 V		CSDIP56	
ST92E163R4G0			4.0-5.5 V		CQFP64	
ST92T163N4B1	20K OTP		4.0-5.5 V		PSDIP56	
ST92T163R4T1			4.0-5.5 V		TQFP64	
ST92163N4B1E/xxx ²⁾	20K ROM		4.0-5.5 V		PSDIP56	
ST92163R4T1E/xxx ²⁾			4.0-5.5 V		TQFP64	
ST92E163N4D1E	20K EPROM		4.0-5.5 V		CSDIP56	
ST92E163R4G1E			4.0-5.5 V		CQFP64	
ST92T163N4B1E	20K OTP		4.0-5.5 V		PSDIP56	
ST92T163R4T1E			4.0-5.5 V		TQFP64	
ST92163R4T1L/xxx ²⁾	20K ROM		Normal and 8-MHz Low Voltage	8-MHz LVM ³⁾	3.0-4.0 V (@8Mhz)	TQFP64
				NM ³⁾	4.0-5.5 V	
ST92E163R4G1L	20K EPROM	8-MHz LVM ³⁾		3.0-4.0 V (@8Mhz)	CQFP64	
		NM ³⁾		4.0-5.5 V		
ST92E163N4D1L	20K EPROM	8-MHz LVM ³⁾		3.0-4.0 V (@8Mhz)	CSDIP56	
		NM ³⁾		4.0-5.5 V		
ST92T163R4T1L	20K OTP	8-MHz LVM ³⁾		3.0-4.0 V (@8Mhz)	TQFP64	
		NM ³⁾		4.0-5.5 V		
ST92163R4T1V/xxx ²⁾	20K ROM	16-MHz LVM ³⁾		3.0V-4.0 (@16Mhz)	TQFP64	
		8-MHz LVM ³⁾		3.0V-4.0 (@8Mhz)		
		NM ³⁾		4.0-5.5V		
ST92E163R4T1V ²⁾	20K EPROM	16-MHz LVM ³⁾		3.0V-4.0 (@16Mhz)	CQFP64	
		8-MHz LVM ³⁾		3.0V-4.0 (@8Mhz)		
		NM ³⁾		4.0-5.5V		
ST92E163N4D1V ²⁾	20K EPROM	16-MHz LVM ³⁾	3.0V-4.0 (@16Mhz)	CSDIP56		
		8-MHz LVM ³⁾	3.0V-4.0 (@8Mhz)			
		NM ³⁾	4.0-5.5V			
ST92T163R4T1V ²⁾	20K OTP	16-MHz LVM ³⁾	3.0V-4.0 (@16Mhz)	TQFP64		
		8-MHz LVM ³⁾	3.0V-4.0 (@8Mhz)			
		NM ³⁾	4.0-5.5V			

Note 1: xxx stands for the ROM code name assigned by STMicroelectronics

Note 2: Contact sales office for availability

Note 3: LVM = Low Voltage Mode and NM = Normal Mode

STMicroelectronics OPTION LIST

ST92163 MICROCONTROLLER FAMILY (ROM DEVICE)

Customer:
 Address:

 Contact:
 Phone No:
 Reference/ROM Code* :

*The ROM code name is assigned by STMicroelectronics.

STMicroelectronics reference:

Device (PSDIP56): ST92163N4B1/xxx*
 ST92163N4B1E/xxx*

Device (TQFP64): ST92163R4T1/xxx*
 ST92163R4T1E/xxx*
 ST92163R4T1L/xxx*
 ST92163R4T1V/xxx*

*xxx = ROM code name

Software Development: STMicroelectronics
 Customer
 External laboratory

Special Marking: No Yes "-----"

For marking, one line is possible with maximum 13 characters.

Authorized characters are letters, digits, '.', '-', '/' and spaces only.

We have checked the ROM code verification file returned to us by STMicroelectronics. It conforms exactly with the ROM code file originally supplied. We therefore authorize STMicroelectronics to proceed with device manufacture.

Signature

Date

Notes:



Information furnished is believed to be accurate and reliable. However, STMicroelectronics assumes no responsibility for the consequences of use of such information nor for any infringement of patents or other rights of third parties which may result from its use. No license is granted by implication or otherwise under any patent or patent rights of STMicroelectronics. Specifications mentioned in this publication are subject to change without notice. This publication supersedes and replaces all information previously supplied. STMicroelectronics products are not authorized for use as critical components in life support devices or systems without the express written approval of STMicroelectronics.

The ST logo is a registered trademark of STMicroelectronics

©2000 STMicroelectronics - All Rights Reserved.

Purchase of I²C Components by STMicroelectronics conveys a license under the Philips I²C Patent. Rights to use these components in an I²C system is granted provided that the system conforms to the I²C Standard Specification as defined by Philips.

STMicroelectronics Group of Companies

Australia - Brazil - China - Finland - France - Germany - Hong Kong - India - Italy - Japan - Malaysia - Malta - Morocco - Singapore - Spain
Sweden - Switzerland - United Kingdom - U.S.A.

<http://www.st.com>