

FEATURES

- **nvSRAM Combined With Integrated Real-Time Clock Functions (RTC, Watchdog Timer, Clock Alarm, Power Monitor)**
- **Capacitor or Battery Backup for RTC**
- **25, 45 ns Read Access & R/W Cycle Time**
- **Unlimited Read/Write Endurance**
- **Automatic Non-volatile STORE on Power Loss**
- **Non-Volatile STORE Under Hardware or Software Control**
- **Automatic RECALL to SRAM on Power Up**
- **Unlimited RECALL Cycles**
- **200K STORE Cycles**
- **20-Year Non-volatile Data Retention**
- **Single 3 V + 20%, -10% Power Supply**
- **Commercial and Industrial Temperatures**
- **Small Footprint SSOP Package (RoHS-Compliant)**

DESCRIPTION

The Simtek STK17T88 combines a 256Kb non-volatile static RAM (nvSRAM) with a full-featured real-time clock in a reliable, monolithic integrated circuit.

The 256Kbit nvSRAM is a fast static RAM with a non-volatile Quantum Trap storage element included with each memory cell.

The SRAM provides the fast access & cycle times, ease of use and unlimited read & write endurance of a normal SRAM. Data transfers automatically to the non-volatile storage cells when power loss is detected (the *STORE* operation). On power up, data is automatically restored to the SRAM (the *RECALL* operation). Both *STORE* and *RECALL* operations are also available under software control.

The real time clock function provides an accurate clock with leap year tracking and a programmable, high accuracy oscillator. The Alarm function is programmable for one-time alarms or periodic minutes, hours, or days alarms. There is also a programmable watchdog timer for processor control.

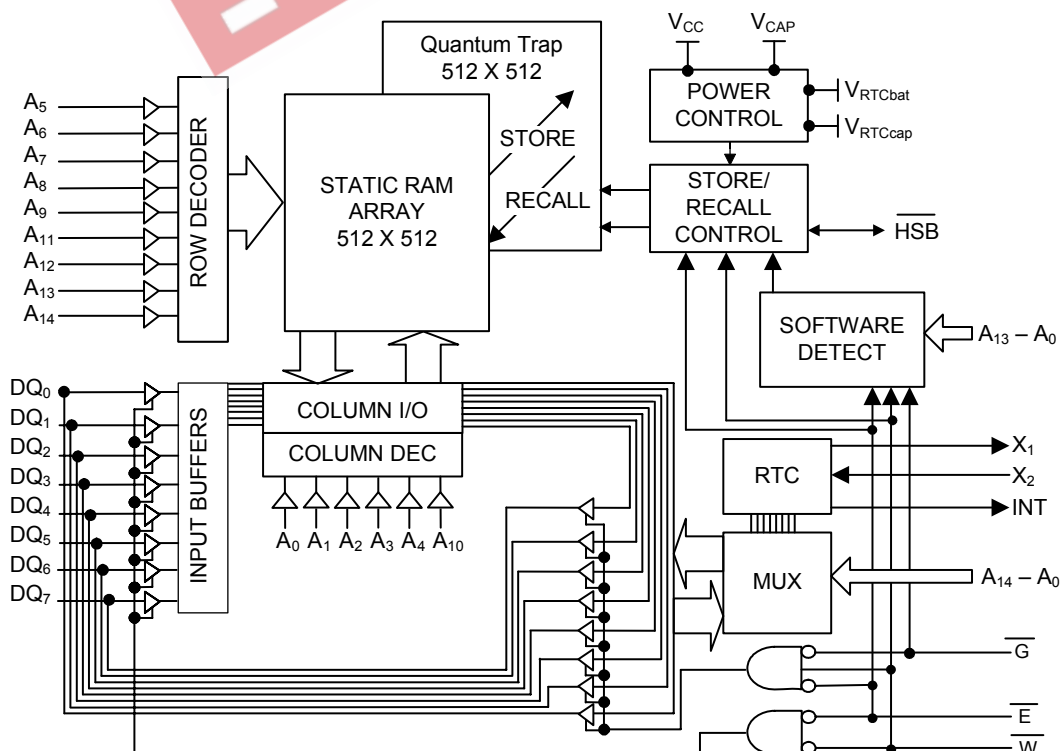
BLOCK DIAGRAM

STK17T88

Pin Configurations

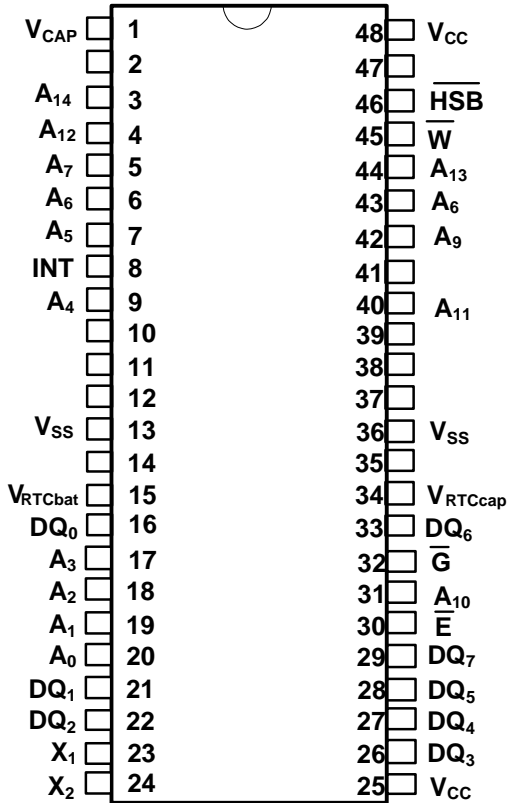

For detailed package size specifications, see page 25.

48 Pin SSOP

PIN DESCRIPTIONS

Pin Name	I/O	Description
A ₁₄ -A ₀	Input	Address: The 15 address inputs select one of 32,768 bytes in the nvSRAM array or one of 16 bytes in the clock register map
DQ ₇ -DQ ₀	I/O	Data: Bi-directional 8-bit data bus for accessing the nvSRAM and RTC
\bar{E}	Input	Chip Enable: The active low \bar{E} input selects the device
\bar{W}	Input	Write Enable: The active low \bar{W} enables data on the DQ pins to be written to the address location selected on the falling edge of \bar{E}
\bar{G}	Input	Output Enable: The active low \bar{G} input enables the data output buffers during read cycles. De-asserting \bar{G} high caused the DQ pins to tri-state.
X ₁	Output	Crystal Connection, drives crystal on startup
X ₂	Input	Crystal Connection for 32.768 kHz crystal
V _{RTCcap}	Power Supply	Capacitor supplied backup RTC supply voltage (Left unconnected if V _{RTCbat} is used)
V _{RTCbat}	Power Supply	Battery supplied backup RTC supply voltage (Left unconnected if V _{RTCcap} is used)
V _{CC}	Power Supply	Power: 3.0V, +20%, -10%
\bar{HSB}	I/O	Hardware Store Busy: When low this output indicates a Store is in progress. When pulled low external to the chip, it will initiate a nonvolatile STORE operation. A weak pull up resistor keeps this pin high if not connected. (Connection Optional).
INT	Output	Interrupt Control: Can be programmed to respond to the clock alarm, the watchdog timer and the power monitor. Programmable to either active high (push/pull) or active low (open-drain)
V _{CAP}	Power Supply	AutoStore Capacitor: Supplies power to nvSRAM during power loss to store data from SRAM to nonvolatile storage elements.
V _{SS}	Power Supply	Ground
(Blank)	No Connect	Unlabeled pins have no internal connections.

ABSOLUTE MAXIMUM RATINGS^a

Voltage on Input Relative to Ground -0.5V to 4.1V
 Voltage on Input Relative to V_{SS} -0.5V to (V_{CC} + 0.5V)
 Voltage on DQ₀₋₇ or HSB -0.5V to (V_{CC} + 0.5V)
 Temperature under Bias -55°C to 125°C
 Junction Temperature -55°C to 140°C
 Storage Temperature -65°C to 150°C
 Power Dissipation 1W
 DC Output Current (1 output at a time, 1s duration) 15mA

Note a: Stresses greater than those listed under “Absolute Maximum Ratings” may cause permanent damage to the device. This is a stress rating only, and functional operation of the device at conditions above those indicated in the operational sections of this specification is not implied. Exposure to absolute maximum rating conditions for extended periods may affect reliability.

Package Thermal Characteristics—See Website at <http://www.simtek.com>

DC CHARACTERISTICS

(V_{CC} = 2.7V-3.6V)

SYMBOL	PARAMETER	COMMERCIAL		INDUSTRIAL		UNITS	NOTES
		MIN	MAX	MIN	MAX		
I _{CC1}	Average V _{CC} Current		65 50		70 55	mA mA	t _{AVAV} = 25ns t _{AVAV} = 45ns Dependent on output loading and cycle rate. Values obtained without output loads.
I _{CC2}	Average V _{CC} Current during STORE		3		3	mA	All Inputs Don't Care, V _{CC} = max Average current for duration of STORE cycle (t _{STORE})
I _{CC3}	Average V _{CC} Current at t _{AVAV} = 200ns 3V, 25°C, Typical		10		10	mA	$\bar{W} \geq (V_{CC} - 0.2V)$ All Other Inputs Cycling at CMOS Levels Dependent on output loading and cycle rate. Values obtained without output loads.
I _{CC4}	Average V _{CAP} Current during AutoStore Cycle		3		3	mA	All Inputs Don't Care Average current for duration of STORE cycle (t _{STORE})
I _{SB}	V _{CC} Standby Current (Standby, Stable CMOS Levels)		3		3	mA	$\bar{E} \geq (V_{CC} - 0.2V)$ All Others V _{IN} ≤ 0.2V or ≥ (V _{CC} -0.2V) Standby current level after nonvolatile cycle complete
I _{ILK}	Input Leakage Current		±1		±1	µA	V _{CC} = max V _{IN} = V _{SS} to V _{CC}
I _{OLK}	Off-State Output Leakage Current		±1		±1	µA	V _{CC} = max V _{IN} = V _{SS} to V _{CC} , \bar{E} or $\bar{G} \geq V_{IH}$
V _{IH}	Input Logic “1” Voltage	2.0	V _{CC} + 0.3	2.0	V _{CC} + 0.3	V	All Inputs
V _{IL}	Input Logic “0” Voltage	V _{SS} - 0.5	0.8	V _{SS} - 0.5	0.8	V	All Inputs
V _{OH}	Output Logic “1” Voltage	2.4		2.4		V	I _{OUT} = -2mA
V _{OL}	Output Logic “0” Voltage		0.4		0.4	V	I _{OUT} = 4mA
T _A	Operating Temperature	0	70	-40	85	°C	
V _{CC}	Operating Voltage	2.7	3.6	2.7	3.6	V	3.3V + 0.3V
V _{CAP}	Storage Capacitance	17	57	17	57	µF	Between V _{CAP} pin and V _{SS} , 5V rated.
NV _C	Nonvolatile STORE operations	200		200		K	
DATA _R	Data Retention	20		20		Years	@ 55 deg C

Note: The HSB pin has I_{OUT} = -10 µA for V_{OH} of 2.4 V, this parameter is characterized but not tested.

Note: The INT pin is open-drain and does not source or sink high current when Interrupt Register bit D3 is low.

STK17T88

AC TEST CONDITIONS

Input Pulse Levels	0V to 3V
Input Rise and Fall Times	≤ 5ns
Input and Output Timing Reference Levels	1.5V
Output Load	See Figure 1 and 2

CAPACITANCE^b (T_A = 25°C, f = 1.0MHz)

SYMBOL	PARAMETER	MAX	UNITS	CONDITIONS
C _{IN}	Input Capacitance	7	pF	ΔV = 0 to 3V
C _{OUT}	Output Capacitance	7	pF	ΔV = 0 to 3V

Note b: These parameters are guaranteed but not tested.

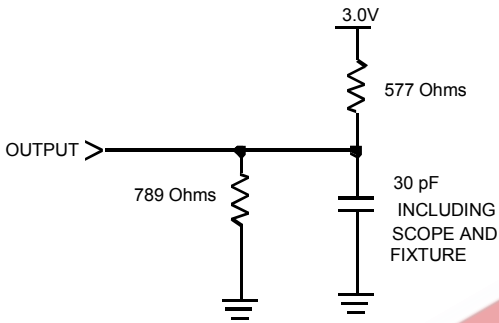

Figure 1. AC Output Loading

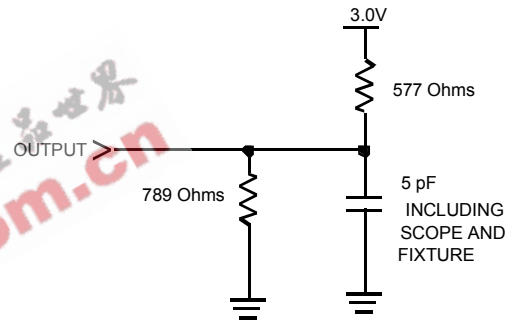
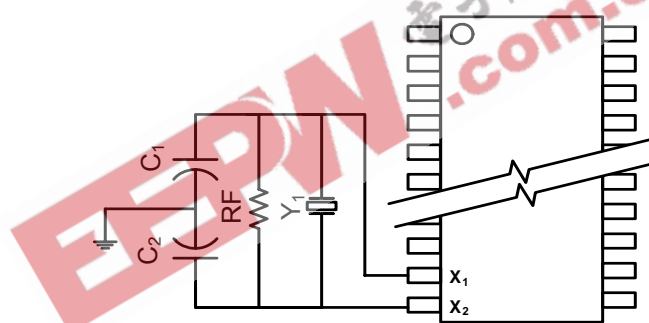

Figure 2. AC Output Loading for tristate specs (T_{HZ}, t_{LZ}, t_{WLQZ}, t_{WHQZ}, t_{GLQX}, t_{GHQZ})

RTC DC CHARACTERISTICS

Symbol	Parameter	Commercial		Industrial		Units	Notes
		Min	Max	Min	Max		
I _{BAK}	RTC Backup Current	—	300	—	350	nA	From either V _{RTCcap} or V _{RTCbat}
V _{RTCbat}	RTC Battery Pin Voltage	1.8	3.3	1.8	3.3	V	Typical = 3.0 Volts during normal operation
V _{RTCcap}	RTC Capacitor Pin Voltage	1.2	2.7	1.2	2.7	V	Typical = 2.4 Volts during normal operation
t _{oscs}	RTC Oscillator time to start	—	10	—	10	sec	@ MIN Temperature from Power up or Enable
		—	5	—	5	sec	@ 25°C from Power up or Enable

RTC RECOMMENDED COMPONENT CONFIGURATION



Recommended Values

Y₁ = 32.768 KHz

RF = 10M Ohm

C₁ = 0

C₂ = 56 pF

Figure 3. RTC COMPONENT CONFIGURATION

SRAM READ CYCLES #1 & #2

NO.	SYMBOLS			PARAMETER	STK17T88-25		STK17T88-45		UNITS
	#1	#2	Alt.		MIN	MAX	MIN	MAX	
1		t_{ELQV}	t_{ACS}	Chip Enable Access Time		25		45	ns
2	t_{AVAV}^c	t_{AVAV}^e	t_{RC}	Read Cycle Time	25		45		ns
3	t_{AVQV}^d	t_{AVQV}^f	t_{AA}	Address Access Time		25		45	ns
4		t_{GLQV}	t_{OE}	Output Enable to Data Valid		12		20	ns
5	t_{AXQX}^d	t_{AXQX}	t_{OH}	Output Hold after Address Change	3		3		ns
6		t_{ELQX}	t_{LZ}	Chip Enable to Output Active	3		3		ns
7		t_{EHQZ}	t_{HZ}	Chip Disable to Output Inactive		10		15	ns
8		t_{GLQX}	t_{OLZ}	Output Enable to Output Active	0		0		ns
9		t_{GHQZ}^e	t_{OHZ}	Output Disable to Output Inactive		10		15	ns
10		t_{ELICCL}^c	t_{PA}	Chip Enable to Power Active	0		0		ns
11		t_{EHICCH}^c	t_{PS}	Chip Disable to Power Standby		25		45	ns

Note c: \bar{W} must be high during SRAM READ cycles.

Note d: Device is continuously selected with \bar{E} and \bar{G} both low

Note e: Measured $\pm 200mV$ from steady state output voltage.

Note f: HSB must remain high during READ and WRITE cycles.

SRAM READ CYCLE #1: Address Controlled^{c,d,f}

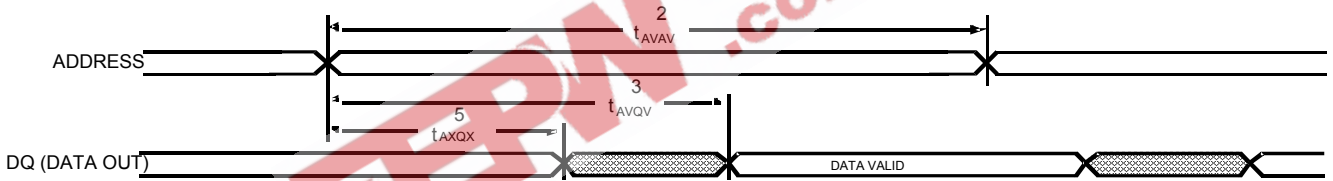

SRAM READ CYCLE #2: \bar{E} Controlled^{a,f}

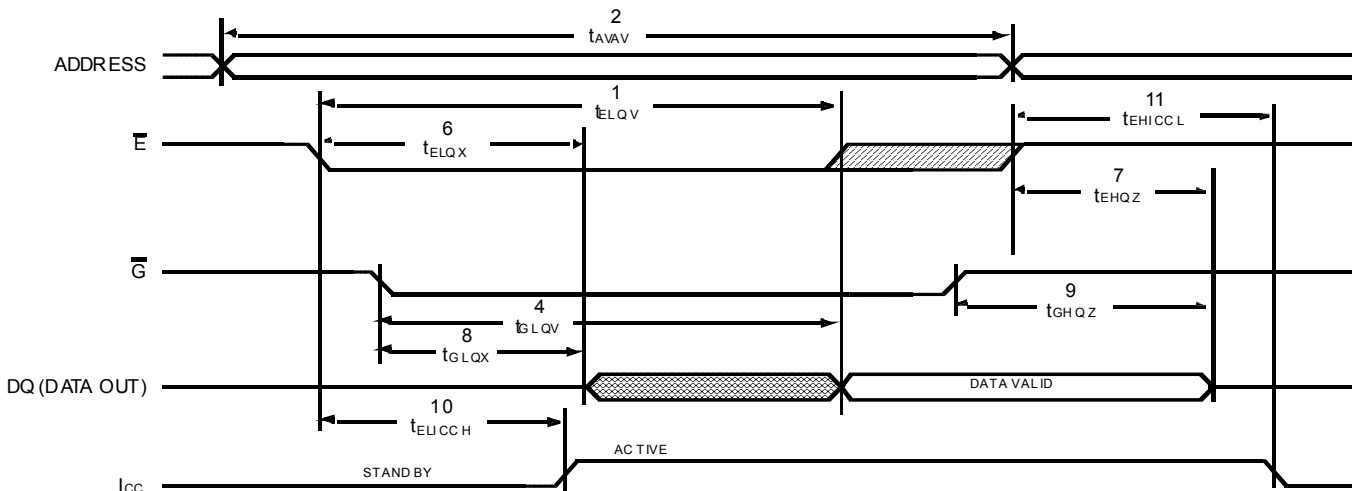

SRAM WRITE CYCLES #1 & #2

NO.	SYMBOLS			PARAMETER	STK17T88-25		STK17T88-45		UNITS
	#1	#2	Alt.		MIN	MAX	MIN	MAX	
12	t_{AVAV}	t_{AVAV}	t_{WC}	Write Cycle Time	25		45		ns
13	t_{WLWH}	t_{WLEH}	t_{WP}	Write Pulse Width	20		30		ns
14	t_{ELWH}	t_{ELEH}	t_{CW}	Chip Enable to End of Write	20		30		ns
15	t_{DVWH}	t_{DVEH}	t_{DW}	Data Set-up to End of Write	10		15		ns
16	t_{WHDX}	t_{EHDX}	t_{DH}	Data Hold after End of Write	0		0		ns
17	t_{AVWH}	t_{AVEH}	t_{AW}	Address Set-up to End of Write	20		30		ns
18	t_{AVWL}	t_{AVEL}	t_{AS}	Address Set-up to Start of Write	0		0		ns
19	t_{WHAX}	t_{EHAX}	t_{WR}	Address Hold after End of Write	0		0		ns
20	t_{WLQZ}		t_{WZ}	Write Enable to Output Disable		10		15	ns
21	t_{WHQX}		t_{OW}	Output Active after End of Write	3		3		ns

note g: If \bar{W} is low when \bar{E} goes low, the outputs remain in the high-impedance state.

note h: \bar{E} or \bar{W} must be $\geq V_{IH}$ during address transitions.

SRAM WRITE CYCLE #1: \bar{W} Controlled^{g,h}

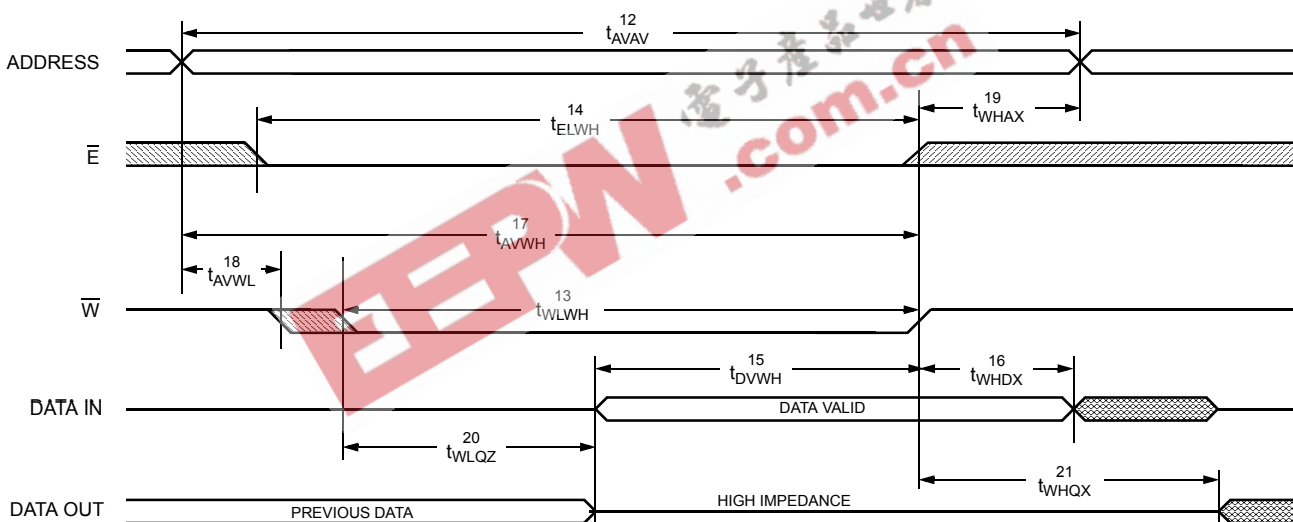

SRAM WRITE CYCLE #2: \bar{E} Controlled^{g,h}

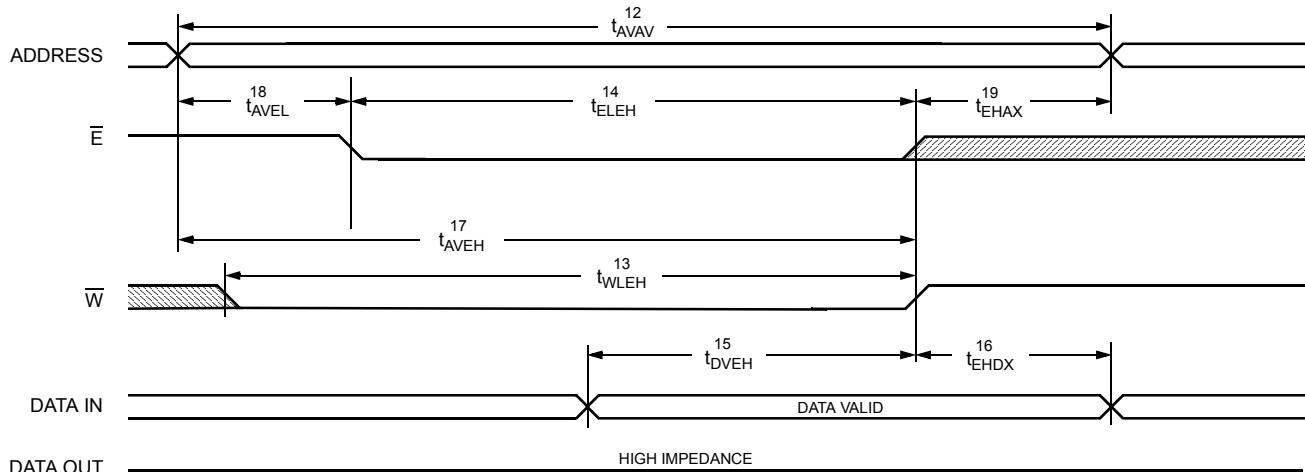

STK17T88

AutoStore/POWER-UP RECALL

NO.	SYMBOLS		PARAMETER	STK17T88		UNITS	NOTES
	Standard	Alternate		MIN	MAX		
22	$t_{HRECALL}$		Power-up <i>RECALL</i> Duration		40	ms	i
23	t_{STORE}	t_{HLHZ}	<i>STORE</i> Cycle Duration		12.5	ms	j,k
24	V_{SWITCH}		Low Voltage Trigger Level		2.65	V	
25	V_{CCRISE}		V_{CC} Rise Time	150		μ S	

note i: $t_{HRECALL}$ starts from the time V_{CC} rises above V_{SWITCH}

note j: If an SRAM WRITE has not taken place since the last nonvolatile cycle, no STORE will take place

note k: Industrial Grade Devices require 15 ms MAX.

AutoStore/POWER-UP RECALL

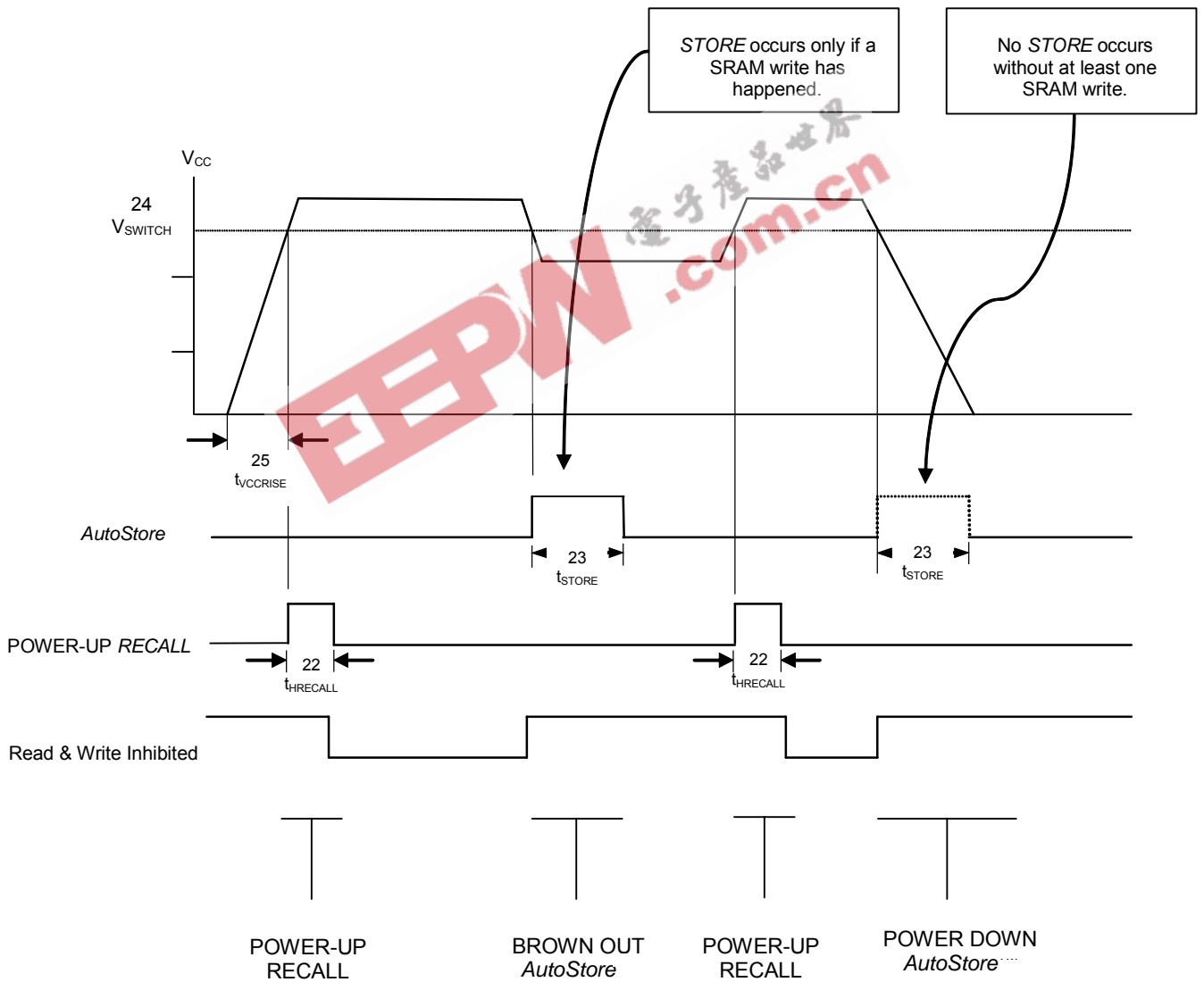

Note: Read and Write cycles will be ignored during STORE, RECALL and while V_{CC} is below V_{SWITCH}

SOFTWARE-CONTROLLED STORE/RECALL CYCLE^{l,m}

NO.	SYMBOLS		PARAMETER	STK17T88-35		STK17T88-45		UNITS	NOTES
	\bar{E} Cont	Alternate		MIN	MAX	MIN	MAX		
26	t_{AVAV}	t_{RC}	STORE / RECALL Initiation Cycle Time	25		45		ns	m
27	t_{AVEL}	t_{AS}	Address Set-up Time	0		0		ns	
28	t_{ELEH}	t_{CW}	Clock Pulse Width	20		30		ns	
29	t_{EHAX}		Address Hold Time	1		1		ns	
30	t_{RECALL}		RECALL Duration		100		100	μ s	

note l: The software sequence is clocked with \bar{E} controlled READs

note m: The six consecutive addresses must be read in the order listed in the Mode Selection Table. \bar{W} must be high during all six consecutive cycles.

SOFTWARE STORE/RECALL CYCLE: \bar{E} CONTROLLED^m

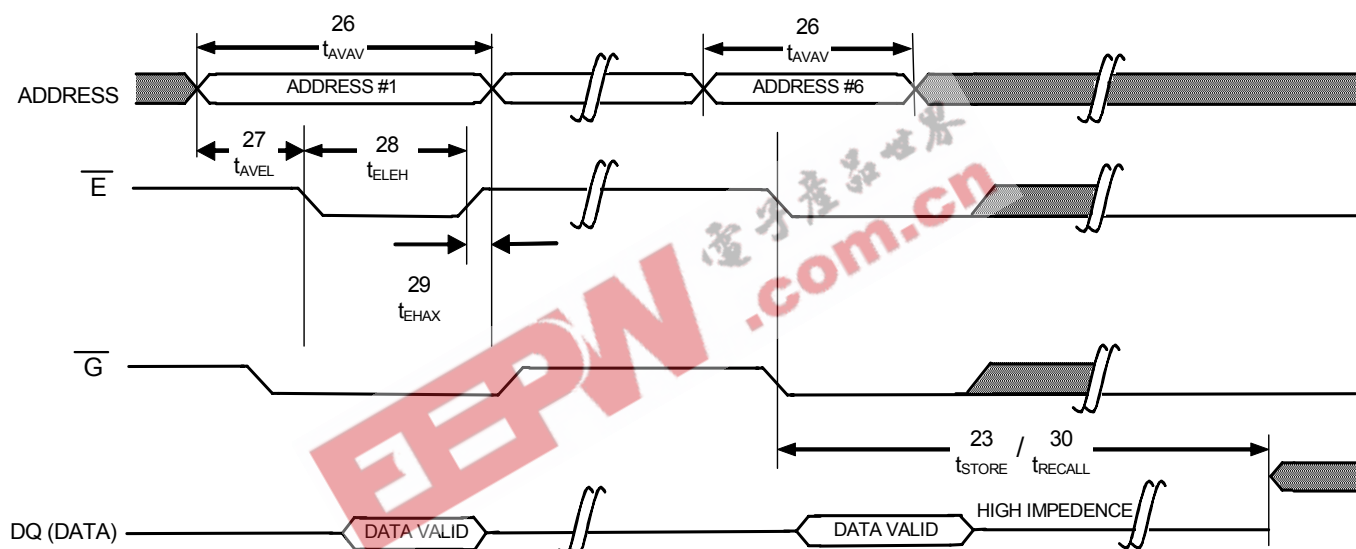

HARDWARE STORE CYCLE

	SYMBOLS		PARAMETER	STK17T88		UNITS	NOTES
	Standard	Alternate		MIN	MAX		
31	t_{DELAY}	t_{HLQZ}	Hardware STORE to SRAM Disabled	1	70	μ s	n
32	t_{HLHX}		Hardware STORE Pulse Width	15		ns	

Note n: On a hardware STORE initiation, SRAM operation continues to be enabled for time t_{DELAY} to allow read/write cycles to complete

HARDWARE STORE CYCLE

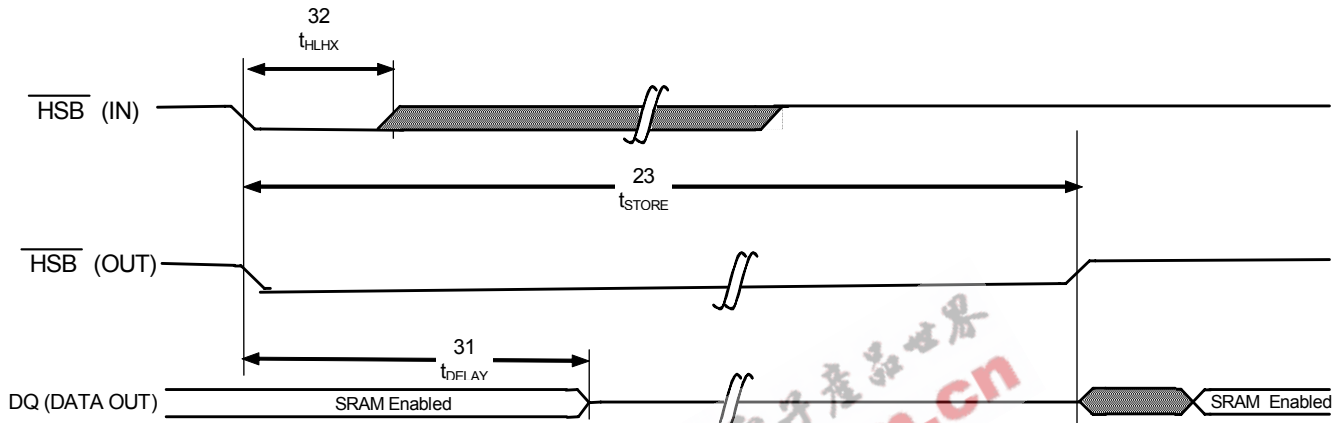

Soft Sequence Commands

NO.	SYMBOLS		PARAMETER	STK17T88		UNITS	NOTES
	Standard			MIN	MAX		
33	t_{SS}		Soft Sequence Processing Time		70	μ s	o,p

note o: This is the amount of time that it takes to take action on a soft sequence command. Vcc power must remain high to effectively register command.

note p: Commands like Store and Recall lock out I/O until operation is complete which further increases this time. See specific command.

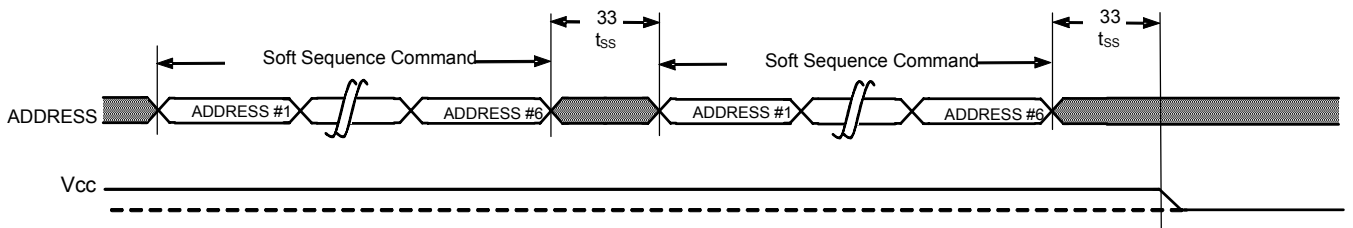

MODE SELECTION

\bar{E}	\bar{W}	\bar{G}	A ₁₃ -A ₀	Mode	I/O	Power	Notes
H	X	X	X	Not Selected	Output High Z	Standby	
L	H	L	X	Read SRAM	Output Data	Active	
L	L	X	X	Write SRAM	Input Data	Active	
L	H	L	0x0E38 0x31C7 0x03E0 0x3C1F 0x303F 0x0FC0	Read SRAM Read SRAM Read SRAM Read SRAM Read SRAM Nonvolatile Store	Output Data Output Data Output Data Output Data Output Data Output High Z	Active I _{CC2}	q,r,s
L	H	L	0x0E38 0x31C7 0x03E0 0x3C1F 0x303F 0x0C63	Read SRAM Read SRAM Read SRAM Read SRAM Read SRAM Nonvolatile Recall	Output Data Output Data Output Data Output Data Output Data Output High Z	Active	q,r,s

note q: The six consecutive addresses must be in the order listed. \bar{W} must be high during all six consecutive cycles to enable a nonvolatile cycle.

note r: While there are 15 addresses on the STK17T88, only the lower 13 are used to control software modes

note s: I/O state depends on the state of \bar{G} . The I/O table shown assumes \bar{G} low

nvSRAM OPERATION

nvSRAM

The STK17T88 nvSRAM is made up of two functional components paired in the same physical cell. These are the SRAM memory cell and a nonvolatile QuantumTrap cell. The SRAM memory cell operates like a standard fast static RAM. Data in the SRAM can be transferred to the nonvolatile cell (the STORE operation), or from the nonvolatile cell to SRAM (the RECALL operation). This unique architecture allows all cells to be stored and recalled in parallel. During the STORE and RECALL operations SRAM READ and WRITE operations are inhibited. The STK17T88 supports unlimited read and writes like a typical SRAM. In addition, it provides unlimited RECALL operations from the nonvolatile cells and up to 200K STORE operations.

SRAM READ

The STK17T88 performs a READ cycle whenever \overline{E} and \overline{G} are low while \overline{W} and \overline{HSB} are high. The address specified on pins A_{0-14} determine which of the 32,768 data bytes will be accessed. When the READ is initiated by an address transition, the outputs will be valid after a delay of t_{AVQV} (READ cycle #1). If the READ is initiated by \overline{E} and \overline{G} , the outputs will be valid at t_{ELQV} or at t_{GLQV} , whichever is later (READ cycle #2). The data outputs will repeatedly respond to address changes within the t_{AVQV} access time without the need for transitions on any control input pins, and will remain valid until another address change or until \overline{E} or \overline{G} is brought high, or \overline{W} and \overline{HSB} is brought low.

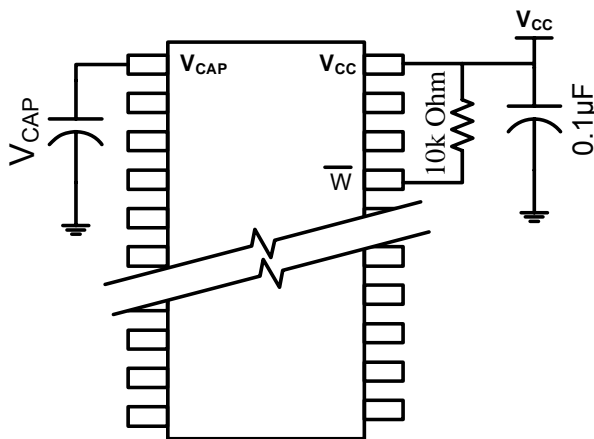

Figure 4: AutoStore Mode

SRAM WRITE

A WRITE cycle is performed whenever \overline{E} and \overline{W} are low and \overline{HSB} is high. The address inputs must be stable prior to entering the WRITE cycle and must remain stable until either \overline{E} or \overline{W} goes high at the end of the cycle. The data on the common I/O pins DQ0-7 will be written into memory if it is valid t_{DVWH} before the end of a \overline{W} controlled WRITE or t_{DVEH} before the end of an \overline{E} controlled WRITE.

It is recommended that \overline{G} be kept high during the entire WRITE cycle to avoid data bus contention on common I/O lines. If \overline{G} is left low, internal circuitry will turn off the output buffers t_{WLQZ} after \overline{W} goes low.

AutoStore OPERATION

The STK17T88 stores data to nvSRAM using one of three storage operations. These three operations are Hardware Store (activated by HSB), Software Store (activated by an address sequence), and AutoStore (on power down).

AutoStore operation, a unique feature of Simtek QuantumTrap technology that is a standard feature on the STK17T88.

During normal operation, the device will draw current from V_{CC} to charge a capacitor connected to the V_{CAP} pin. This stored charge will be used by the chip to perform a single STORE operation. If the voltage on the V_{CC} pin drops below V_{SWITCH} , the part will automatically disconnect the V_{CAP} pin from V_{CC} . A STORE operation will be initiated with power provided by the V_{CAP} capacitor.

Figure 5 shows the proper connection of the storage capacitor (V_{CAP}) for automatic store operation. Refer to the DC CHARACTERISTICS table for the size of V_{CAP} . The voltage on the V_{CAP} pin is driven to 5V by a charge pump internal to the chip. A pull up should be placed on \overline{W} to hold it inactive during power up.

To reduce unneeded nonvolatile stores, AutoStore and Hardware Store operations will be ignored unless at least one WRITE operation has taken place since the most recent STORE or RECALL cycle. Software initiated STORE cycles are performed regardless of whether a WRITE operation

has taken place. The $\overline{\text{HSB}}$ signal can be monitored by the system to detect an AutoStore cycle is in progress.

HARDWARE STORE ($\overline{\text{HSB}}$) OPERATION

The STK17T88 provides the $\overline{\text{HSB}}$ pin for controlling and acknowledging the *STORE* operations. The $\overline{\text{HSB}}$ pin can be used to request a hardware *STORE* cycle. When the $\overline{\text{HSB}}$ pin is driven low, the STK17T88 will conditionally initiate a *STORE* operation after t_{DELAY} . An actual *STORE* cycle will only begin if a *WRITE* to the SRAM took place since the last *STORE* or *RECALL* cycle. The $\overline{\text{HSB}}$ pin also acts as an open drain driver that is internally driven low to indicate a busy condition while the *STORE* (initiated by any means) is in progress. This pin should be externally pulled up if it is used to drive other inputs.

SRAM READ and WRITE operations that are in progress when $\overline{\text{HSB}}$ is driven low by any means are given time to complete before the *STORE* operation is initiated. After $\overline{\text{HSB}}$ goes low, the STK17T88 will continue to allow SRAM operations for t_{DELAY} . During t_{DELAY} , multiple SRAM READ operations may take place. If a WRITE is in progress when $\overline{\text{HSB}}$ is pulled low, it will be allowed a time, t_{DELAY} , to complete. However, any SRAM WRITE cycles requested after $\overline{\text{HSB}}$ goes low will be inhibited until HSB returns high.

During any *STORE* operation, regardless of how it was initiated, the STK17T88 will continue to drive the $\overline{\text{HSB}}$ pin low, releasing it only when the *STORE* is complete. Upon completion of the *STORE* operation, the STK17T88 will remain disabled until the $\overline{\text{HSB}}$ pin returns high.

If $\overline{\text{HSB}}$ is not used, it should be left unconnected.

HARDWARE RECALL (POWER-UP)

During power up or after any low-power condition ($V_{\text{CC}} < V_{\text{SWITCH}}$), an internal RECALL request will be latched. When V_{CC} once again exceeds the sense voltage of V_{SWITCH} , a RECALL cycle will automatically be initiated and will take t_{HRECALL} to complete.

SOFTWARE STORE

Data can be transferred from the SRAM to the non-volatile memory by a software address sequence. The STK17T88 software *STORE* cycle is initiated by

executing sequential $\overline{\text{E}}$ controlled READ cycles from six specific address locations in exact order. During the *STORE* cycle, previous data is erased and then the new data is programmed into the nonvolatile elements. Once a *STORE* cycle is initiated, further memory inputs and outputs are disabled until the cycle is completed.

To initiate the software *STORE* cycle, the following READ sequence must be performed:

1	Read Address	0x0E38	Valid READ
2	Read Address	0x31C7	Valid READ
3	Read Address	0x03E0	Valid READ
4	Read Address	0x3C1F	Valid READ
5	Read Address	0x303F	Valid READ
6	Read Address	0x0FC0	Initiate STORE Cycle

Once the sixth address in the sequence has been entered, the *STORE* cycle will commence and the chip will be disabled. It is important that READ cycles and not WRITE cycles be used in the sequence. After the t_{STORE} cycle time has been fulfilled, the SRAM will again be activated for READ and WRITE operation.

SOFTWARE RECALL

Data can be transferred from the nonvolatile memory to the SRAM by a software address sequence. A software *RECALL* cycle is initiated with a sequence of READ operations in a manner similar to the software *STORE* initiation. To initiate the *RECALL* cycle, the following sequence of $\overline{\text{E}}$ controlled READ operations must be performed:

1	Read Address	0x0E38	Valid READ
2	Read Address	0x31C7	Valid READ
3	Read Address	0x03E0	Valid READ
4	Read Address	0x3C1F	Valid READ
5	Read Address	0x303F	Valid READ
6	Read Address	0x0FC0	Initiate STORE Cycle

Internally, *RECALL* is a two-step procedure. First, the SRAM data is cleared, and second, the nonvolatile information is transferred into the SRAM cells. After the t_{RECALL} cycle time, the SRAM will once again be ready for READ or WRITE operations. The *RECALL* operation in no way alters the data in the nonvolatile storage elements.

DATA PROTECTION

The STK17T88 protects data from corruption during low-voltage conditions by inhibiting all externally initiated STORE and WRITE operations. The low-voltage condition is detected when $V_{CC} < V_{SWITCH}$.

If the STK17T88 is in a WRITE mode (both \overline{E} and \overline{W} low) at power-up, after a *RECALL*, or after a STORE, the WRITE will be inhibited until a negative transition on \overline{E} or \overline{W} is detected. This protects against inadvertent writes during power up or brown out conditions.

NOISE CONSIDERATIONS

The STK17T88 is a high-speed memory and so must have a high-frequency bypass capacitor of approximately 0.1 μF connected between V_{CC} and V_{SS} , using leads and traces that are as short as possible. As with all high-speed CMOS ICs, careful routing of power, ground, and signals will reduce circuit noise.

PREVENTING AutoStore

Because of the use of nvSRAM to store critical RTC data, the AutoStore function can not be disabled on the STK17T88.

LOW AVERAGE ACTIVE POWER

CMOS technology provides the STK17T88 with the benefit of power supply current that scales with cycle time. Less current will be drawn as the memory cycle time becomes longer than 50 ns. Figure 4 shows the relationship between I_{CC} and READ/WRITE cycle time. Worst-case current consumption is shown for commercial temperature range, $V_{CC}=3.6\text{V}$, and chip enable at maximum frequency. Only standby current is drawn when the chip is disabled. The overall average current drawn by the STK17T88 depends on the following items:

1. The duty cycle of chip enable.
2. The overall cycle rate for accesses.
3. The ratio of READs to WRITEs.
4. The operating temperature.
5. The V_{CC} level.
6. I/O loading.

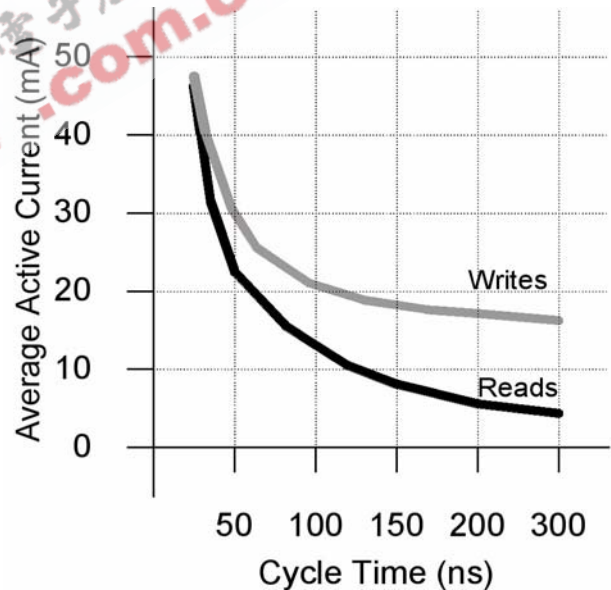

Figure 5. Current vs. Cycle Time

REAL TIME CLOCK OPERATION

REAL TIME CLOCK

The clock registers maintain time up to 9,999 years in one-second increments. The user can set the time to any calendar time and the clock automatically keeps track of days of the week and month, leap years, and century transitions. There are eight registers dedicated to the clock functions which are used to set time with a write cycle and to read time during a read cycle. These registers contain the Time of Day in BCD format. Bits defined as "0" are currently not used and are reserved for future use by Simtek.

READING THE CLOCK

The user should halt internal updates to the real time clock registers before reading clock data to prevent reading of data in transition. Stopping the internal register updates does not affect clock accuracy.

Write a "1" to the read bit "R" (in the Flags register at 0x7FF0) to capture the current time in holding registers. Clock updates do not restart until a "0" is written to the read bit. The RTC registers can now be read while the internal clock continues to run.

Within 20ms after a "0" is written to the read bit, all real time clock registers are simultaneously updated.

SETTING THE CLOCK

Set the write bit "W" (in the Flags register at 0x7FF0) to a "1" enable the time to be set. The correct day, date and time can then be written into the real time clock registers in 24-hour BCD format. The time written is referred to as the "Base Time." This value is stored in non-volatile registers and used in calculation of the current time. Reset the write bit to "0" to transfer the time to the actual clock counters, The clock will start counting at the new base time.

BACKUP POWER

The RTC is intended to keep time even when system power is lost. When primary power, V_{CC} , drops below V_{SWITCH} , the real time clock will switch to the backup power supply connected to either the V_{RTCcap} or V_{RTCbat} pin.

The clock oscillator uses a maximum of 300 nano-amps at 2 volts to maximize the backup time available from the backup source.

You can power the real time clock with either a capacitor or a battery. Factors to be considered when choosing a backup power source include the expected duration of power outages and the cost and reliability trade-off of using a battery versus a capacitor.

If you select a capacitor power source, connect the capacitor to the V_{RTCcap} pin and leave the V_{RTCbat} pin unconnected. Capacitor backup time values based on maximum current specs are shown below. Nominal times are approximately 3 times longer.

Capacitor Value	Backup Time
0.1 F	72 hours
0.47 F	14 days
1.0 F	30 days

A capacitor has the obvious advantage of being more reliable and not containing hazardous materials. The capacitor is recharged every time the power is turned on so that the real time clock continues to have the same backup time over years of operation.

If you select a battery power source, connect the battery to the V_{RTCbat} pin and leave the V_{RTCcap} pin unconnected. A 3V lithium is recommended for this application. The battery capacity should be chosen for the total anticipated cumulative down-time required over the life of the system.

The real time clock is designed with a diode internally connected to the V_{RTCbat} pin. This prevents the battery from ever being charged by the circuit.

STOPPING AND STARTING THE RTC OSCILLATOR

The OSCEN bit in Calibration register at 0x7FF8 enables RTC oscillator operation. This bit is non-volatile and shipped to customers in the "enabled" state (set to 0). OSCEN should be set to a 1 to preserve battery life while the system is in storage. This will turn off the oscillator circuit extending the battery life. If the OSCEN bit goes from disabled to enabled, it will typically take 5 seconds (10 seconds max) for the oscillator to start.

The STK17T88 has the ability to detect oscillator failure due to loss of backup power. The failure is recorded by the OSCF (Oscillator Failed bit) of the Flags register (at address 0x7FF0). When the device is powered on (V_{CC} goes above V_{SWITCH}) the OSCEN bit is checked for "enabled" status. If the OSCEN bit is enabled and the oscillator is not active within 5 ms, the OSCF bit is set. The user should check for this condition and then write a 0 to clear the flag. When the OSCF flag bit, the real time clock registers are reset to the "Base Time" (see the section "Setting the Clock"), the value last written to the real time clock registers.

The value of OSCF should be reset to 0 when the real time clock registers are written for the first time. This will initialize the state of this bit since it may have become set when the system was first powered on.

To reset OSCF, set the write bit "W" (in the Flags register at 0x7FF0) to a "1" to enable writes to the Flags register. Write a "0" to the OSCF bit and then reset the write bit to "0" to disable writes.

CALIBRATING THE CLOCK

The RTC is driven by a quartz controlled oscillator with a nominal frequency of 32.768 KHz. Clock accuracy will depend on the quality of the crystal specified (usually 35 ppm at 25 C). This error could equate to 1.53 minutes gain or loss per month. The STK17T88 employs a calibration circuit that can improve the accuracy to $\pm 1/2$ ppm at 25 C. The calibration circuit adds or subtracts counts from the oscillator divider circuit.

The number of time pulses added or subtracted depends upon the value loaded into the five calibration bits found in Calibration register (at 0x7FF8). Adding counts speeds the clock up; subtracting counts slows the clock down. The Calibration bits occupy the five lower order bits of the register. These bits can be set to represent any value between 0 and 31 in binary form. Bit D5 is a Sign bit, where a "1" indicates positive calibration and a "0" indicates negative calibration. Calibration occurs during a 64 minute period. The first 62 minutes in the cycle may, once per minute, have one second either shortened by 128 or lengthened by 256 oscillator cycles.

If a binary "1" is loaded into the register, only the first 2 minutes of the 64 minute cycle will be modified; if a

binary 6 is loaded, the first 12 will be affected, and so on. Therefore each calibration step has the effect of adding 512 or subtracting 256 oscillator cycles for every 125,829,120 actual oscillator cycles. That is +4.068 or -2.034 ppm of adjustment per calibration step in the Calibration register.

The calibration register value is determined during system test by setting the CAL bit in the Flags register (at 0x7FF0) to 1. This causes the INT pin to toggle at a nominal 512 Hz. This frequency can be measured with a frequency counter. Any deviation measured from the 512 Hz will indicate the degree and direction of the required correction. For example, a reading of 512.01024 Hz would indicate a +20 ppm error, requiring a -10 (001010) to be loaded into the Calibration register. Note that setting or changing the calibration register does not affect the frequency test output frequency.

To set or clear CAL, set the write bit "W" (in the Flags register at 0x7FF0) to a "1" to enable writes to the Flags register. Write a value to CAL and then reset the write bit to "0" to disable writes.

The default Calibration register value from the factory is 00h. The user calibration value loaded is retained during a power loss.

ALARM

The alarm function compares a user-programmed alarm time/date (stored in registers 0x7FF1-5) with the real time clock time-of-day/date values. When a match occurs, the alarm flag (AF) is set and an interrupt is generated if the alarm interrupt is enabled. The alarm flag is automatically reset when the Flags register is read.

Each of the alarm registers has a match bit as its MSB. Setting the match bit to a 1 disables this alarm register from the alarm comparison. When the match bit is 0, the alarm register is compared with the equivalent real time clock register. Using the match bits, an alarm can occur as specifically as one particular second on one day of the month or as frequently as once per minute.

Note: The product requires the match bit for seconds (0x7FF2, bit D7) be set to 0 for proper operation of the Alarm Flag and Interrupt.

The alarm value should be initialized on power-up by software since the alarm registers are not non-volatile.

STK17T88

To set or clear the Alarm registers, set the write bit "W" (in the Flags register at 0x7FF0) to a "1" to enable writes to the Alarm registers. Write an alarm-value to the alarm registers and then reset the write bit to "0" to disable writes.

WATCHDOG TIMER

The watchdog timer is designed to interrupt or reset the processor should its program get hung in a loop and not respond in a timely manner. The software must reload the watchdog timer before it counts down to zero to prevent this interrupt or reset.

The watchdog timer is a free-running-down counter that uses the 32Hz clock (31.25 ms) derived from the crystal oscillator. The watchdog timer function does not operate unless the oscillator is running.

The watchdog counter is loaded with a starting value from the load register and then counts down to zero, setting the watchdog flag (WDF) and generating an interrupt if the watchdog interrupt is enabled. The watchdog flag bit is reset when the Flags register is read. The operating software would normally reload the counter by setting the watchdog strobe bit (WDS) to 1 within the timing interval programmed into the load register.

To use the watchdog timer to reset the processor on timeout, the INT is tied to processor master reset and Interrupt register is programmed to 24h to enable interrupts to pulse the reset pin on timeout.

To load the watchdog timer, set a new value into the load register by writing a "0" to the watchdog write bit (WDW) of the watchdog register (at 0x7FF7). Then load a new value into the load register. Once the new value is loaded, the watchdog write bit is then set to 1 to disable watchdog writes. The watchdog strobe bit (WDS) is set to 1 to load this value into the watchdog timer. Note: Setting the load register to zero will disable the watchdog timer function.

The system software should initialize the watchdog load register on power-up to the desired value since the register is not non-volatile.

POWER MONITOR

The STK17T88 provides a power monitor function. The power monitor is based on an internal band-gap reference circuit that compares the V_{CC} voltage to V_{SWITCH} .

When the power supply drops below V_{SWITCH} , the real time clock circuit is switched to the backup supply (battery or capacitor).

When operating from the backup source, no data may be read or written and the clock functions are not available to the user. The clock continues to operate in the background. Updated clock data is available to the user $t_{HRECALL}$ delay after V_{CC} has been restored to the device.

When the power is lost, the PF flag in the Flags register is set to indicate the power failure and an interrupt is generated if the power fail interrupt is enabled (interrupt register=20h). The INT line would normally be tied to the processor master reset input to perform power-off reset.

INTERRUPTS

The STK17T88 has a Flags register, Interrupt register, and interrupt logic that can interrupt the microcontroller or general a power-up master reset signal. There are three potential interrupt sources: the watchdog timer, the power monitor, and the clock alarm. Each can be individually enabled to drive the INT pin by setting the appropriate bit in the Interrupt register. In addition, each has an associated flag bit in the Flags register that the host processor can read to determine the interrupt source. Two bits in the interrupt register determine the operation of the INT pin driver.

A functional diagram of the interrupt logic is shown below.

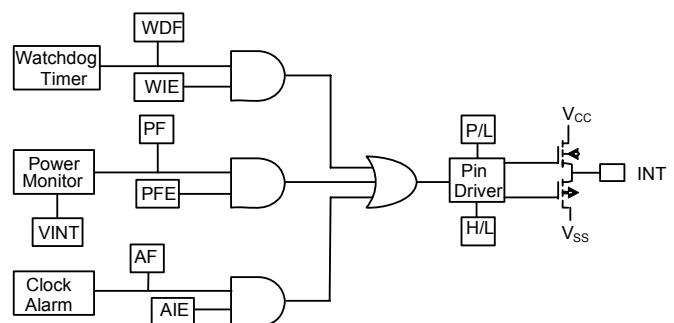

Figure 6. Interrupt Block Diagram

INTERRUPT REGISTER

Watchdog Interrupt Enable (WIE). When set to 1, the watchdog timer drives the INT pin when a watchdog time-out occurs. When WIE is set to 0, the watchdog time-out only sets the WDF flag bit.

Alarm Interrupt Enable (AIE). When set to 1, the INT pin is driven when an alarm match occurs. When set to 0, the alarm match only sets the AF flag bit.

Power Fail Interrupt Enable (PFE). When set to 1, the INT pin is driven by a power fail signal from the power monitor. When set to 0, only the PF flag is set.

High/Low (H/L). When set to a 1, the INT pin is active high and the driver mode is push-pull. The INT pin can drive high only when $V_{CC} > V_{SWITCH}$. When set to a 0, the INT pin is active low and the drive mode is open-drain. The active low (open drain) output is maintained even when power is lost.

Pulse/Level (P/L). When set to a 1, the INT pin is driven for approximately 200 ms when the interrupt occurs. The pulse is reset when the Flags register is read. When P/L is set to a 0, the INT pin is driven high or low (determined by H/L) until the Flags register is read.

The Interrupt register is loaded with the default value 00h at the factory. The user should configure the Interrupt register to the value desired for their desired mode of operation. Once configured, the value is retained during power failures.

FLAGS REGISTER

The Flags register has three flag bits: WDF, AF, and PF. These flags are set by the watchdog time-out, alarm match, or power fail monitor respectively. The processor can either poll this register or enable the interrupts to be informed when a flag is set. The flags are automatically reset once the register is read.

The Flags register is automatically loaded with the value 00h on power up (with the exception of the OSCF bit).

RTC REGISTER MAP

Register	BCD Format Data								Function / Range
	D7	D6	D5	D4	D3	D2	D1	D0	
0x7FFF	10s Years				Years				Years: 00-99
0x7FFE	0	0	0	10s Months	Months				Months: 01-12
0x7FFD	0	0	10s Day of Month		Day of Month				Day of Month: 01-31
0x7FFC	0	0	0	0	0	Day of Week			Day of week: 01-07
0x7FFB	0	0	10s Hours			Hours			Hours: 00-23
0x7FFA	0	10s Minutes			Minutes			Minutes: 00-59	
0x7FF9	0	10s Seconds			Seconds			Seconds: 00-59	
0x7FF8	OSCE N	0	Cal Sign	Calibration				Calibration values*	
0x7FF7	WDS	WDW	WDT					Watchdog*	
0x7FF6	WIE	AIE	PFE	0	H/L	P/L	0	0	Interrupts*
0x7FF5	M	0	10s Alarm Date		Alarm Day			Alarm, Day of Month: 01-31	
0x7FF4	M	0	10s Alarm Hours		Alarm Hours			Alarm, hours: 00-23	
0x7FF3	M	10 Alarm Minutes			Alarm Minutes			Alarm, minutes: 00-59	
0x7FF2	M	10 Alarm Seconds			Alarm Seconds			Alarm, seconds: 00-59	

*A binary value, not a BCD value.

0 - Not implemented, reserved for future use.

Default Settings of non-volatile Calibration and Interrupt registers from factory

Calibration Register=00h

Interrupt Register=00h

The User should configure to the desired value at startup or during operation and the value is then retained during a power failure.

STK17T88

Register Map Detail

0x7FFF	Real Time Clock – Years							
	D7	D6	D5	D4	D3	D2	D1	D0
	10s Years				Years			
	Contains the lower two BCD digits of the year. Lower nibble contains the value for years; upper nibble contains the value for 10s of years. Each nibble operates from 0 to 9. The range for the register is 0-99.							
0x7FFE	Real Time Clock – Months							
	D7	D6	D5	D4	D3	D2	D1	D0
	0	0	0	10s Month	Months			
	Contains the BCD digits of the month. Lower nibble contains the lower digit and operates from 0 to 9; upper nibble (one bit) contains the upper digit and operates from 0 to 1. The range for the register is 1-12.							
0x7FFD	Real Time Clock – Date							
	D7	D6	D5	D4	D3	D2	D1	D0
	0	0	10s Day of month		Day of month			
	Contains the BCD digits for the date of the month. Lower nibble contains the lower digit and operates from 0 to 9; upper nibble contains the upper digit and operates from 0 to 3. The range for the register is 1-31. Leap years are automatically adjusted for.							
0x7FFC	Real Time Clock – Day							
	D7	D6	D5	D4	D3	D2	D1	D0
	0	0	0	0	0	Day of week		
	Lower nibble contains a value that correlates to day of the week. Day of the week is a ring counter that counts from 1 to 7 then returns to 1. The user must assign meaning to the day value, as the day is not integrated with the date.							
0x7FFB	Real Time Clock – Hours							
	D7	D6	D5	D4	D3	D2	D1	D0
	0	0	10s Hours		Hours			
	Contains the BCD value of hours in 24 hour format. Lower nibble contains the lower digit and operates from 0 to 9; upper nibble (two bits) contains the upper digit and operates from 0 to 2. The range for the register is 0-23.							

0x7FFA	Real Time Clock – Minutes							
	D7	D6	D5	D4	D3	D2	D1	D0
	0	10s Minutes			Minutes			
	Contains the BCD value of minutes. Lower nibble contains the lower digit and operates from 0 to 9; upper nibble contains the upper minutes digit and operates from 0 to 5. The range for the register is 0-59.							

0x7FF9	Real Time Clock – Seconds							
	D7	D6	D5	D4	D3	D2	D1	D0
	0	10s Seconds			Seconds			
	Contains the BCD value of seconds. Lower nibble contains the lower digit and operates from 0 to 9; upper nibble contains the upper digit and operates from 0 to 5. The range for the register is 0-59.							

0x7FF8	Calibration							
	D7	D6	D5	D4	D3	D2	D1	D0
	OSCEN	0	Calibration Sign					Calibration
OSCEN	Oscillator Enable. When set to 1, the oscillator is disabled. When set to 0, the oscillator enabled. Disabling the oscillator saves battery/capacitor power during storage.							
Calibration Sign	Determines if the calibration adjustment is applied as an addition to or as a subtraction from the time-base.							
Calibration	These five bits control the calibration of the clock.							

0x7FF7	Watchdog Timer							
	D7	D6	D5	D4	D3	D2	D1	D0
	WDS	WDW						WDT
WDS	Watchdog Strobe. Setting this bit to 1 reloads and restarts the watchdog timer. The bit is cleared automatically once the watchdog timer is reset. The WDS bit is write only. Reading it always will return a 0.							
WDW	Watchdog Write Enable. Set this bit to 1 to disable writing of the watchdog time-out value (WDT5-WDT0). This allows the user to strobe the watchdog without disturbing the time-out value. Setting this bit to 0 allows bits 5-0 to be written.							
WDT	Watchdog time-out selection. The watchdog timer interval is selected by the 6-bit value in this register. It represents a multiplier of the 32 Hz count (31.25 ms). The range or time-out values is 31.25 ms (a setting of 1) to 2 seconds (setting of 3Fh). Setting the watchdog timer register to 0 disables the timer. These bits can be written only if the WDW bit was cleared to 0 on a previous cycle.							

0x7FF6	Interrupt							
	D7	D6	D5	D4	D3	D2	D1	D0
	WIE	AIE	PFIE	ABE	H/L	P/L	0	0
WIE	Watchdog Interrupt Enable. When set to 1 and a watchdog time-out occurs, the watchdog timer drives the INT pin as well as setting the WDF flag. When set to 0, the watchdog time-out only sets the WDF flag.							
AIE	Alarm Interrupt Enable. When set to 1, the alarm match drives the INT pin as well as setting the AF flag. When set to 0, the alarm match only sets the AF flag.							
PFIE	Power-Fail Enable. When set to 1, a power failure drives the INT pin as well as setting the PF flag. When set to 0, a power failure only sets the PF flag.							
0	Reserved for Future Use							
H/L	High/Low. When set to a 1, the INT pin is driven active high. When set to 0, the INT pin is open drain, active low.							
P/L	Pulse/Level. When set to a 1, the INT pin is driven active (determined by H/L) by an interrupt source for approximately 200 ms. When set to a 0, the INT pin is driven to an active level (as set by H/L) until the Flags register is read.							

0x7FF5	Alarm – Day							
	D7	D6	D5	D4	D3	D2	D1	D0
	M	0	10s Alarm Date			Alarm Date		
	Contains the alarm value for the date of the month and the mask bit to select or deselect the date value.							
M	Match. Setting this bit to 0 causes the date value to be used in the alarm match. Setting this bit to 1 causes the match circuit to ignore the date value.							

0x7FF4	Alarm – Hours							
	D7	D6	D5	D4	D3	D2	D1	D0
	M	0	10s Alarm Hours			Alarm Hours		
	Contains the alarm value for the hours and the mask bit to select or deselect the hours value.							
M	Match. Setting this bit to 0 causes the hours value to be used in the alarm match. Setting this bit to 1 causes the match circuit to ignore the hours value.							

0x7FF3	Alarm – Minutes							
	D7	D6	D5	D4	D3	D2	D1	D0
	M	10s Alarm Minutes			Alarm Minutes			
	Contains the alarm value for the minutes and the mask bit to select or deselect the minutes value.							
M	Match. Setting this bit to 0 causes the minutes value to be used in the alarm match. Setting this bit to 1 causes the match circuit to ignore the minutes value.							

0x7FF2	Alarm – Seconds							
	D7	D6	D5	D4	D3	D2	D1	D0
	M	10s Alarm Seconds			Alarm Seconds			
	Contains the alarm value for the seconds and the mask bit to select or deselect the seconds' value.							
M	Match. Setting this bit to 0 causes the seconds' value to be used in the alarm match. Setting this bit to 1 causes the match circuit to ignore the seconds value.							

0x7FF1	Real Time Clock – Centuries							
	D7	D6	D5	D4	D3	D2	D1	D0
	10s Centuries				Centuries			
	Contains the BCD value of Centuries. Lower nibble contains the lower digit and operates from 0 to 9; upper nibble contains the upper centuries digit and operates from 0 to 9. The range for the register is 0-99 centuries.							

0x7FF0	Flags							
	D7	D6	D5	D4	D3	D2	D1	D0
	WDF	AF	PF	OSCF	0	CAL	W	R
WDF	Watchdog Timer Flag. This read-only bit is set to 1 when the watchdog timer is allowed to reach 0 without being reset by the user. It is cleared to 0 when the Flags register is read or on power-up							
AF	Alarm Flag. This read-only bit is set to 1 when the time and date match the values stored in the alarm registers with the match bits = 0. It is cleared when the Flags register is read or on power-up							
PF	Power-fail Flag. This read-only bit is set to 1 when power falls below the power-fail threshold V_{SWITCH} . It is cleared to 0 when the Flags register is read or on power-up.							
OSCF	Oscillator Fail Flag. Set to 1 on power-up only if the oscillator is enabled and not running in the first 5ms of operation. This indicates that the RTC backup power failed and the clock value is no longer valid. The user must reset this bit to 0 to clear this condition.							
CAL	Calibration Mode. When set to 1, a 512Hz square wave is output on the INT pin. When set to 0, the INT pin resumes normal operation. This bit defaults to 0 (disabled) on power up.							
W	Write Time. Setting the W bit to 1 freezes updates of the RTC registers. The user can then write to the RTC registers, Alarm registers, Calibration register, Interrupt register and Flags register. Setting the W bit to 0 disables writes to the registers and causes the contents of the real time clock registers to be transferred to the timekeeping counters if the time has changed (a new base time is loaded). The bit defaults to 0 on power up.							
R	Read Time. Setting the R bit to 1 captures the current time in holding registers so that clock updates are not during during the reading process. Set the R bit to 0 to enable the holding register to resume clock updates. The bit defaults to 0 on power up.							

Commercial and Industrial Ordering Information

STK17T88 R F 45 I TR

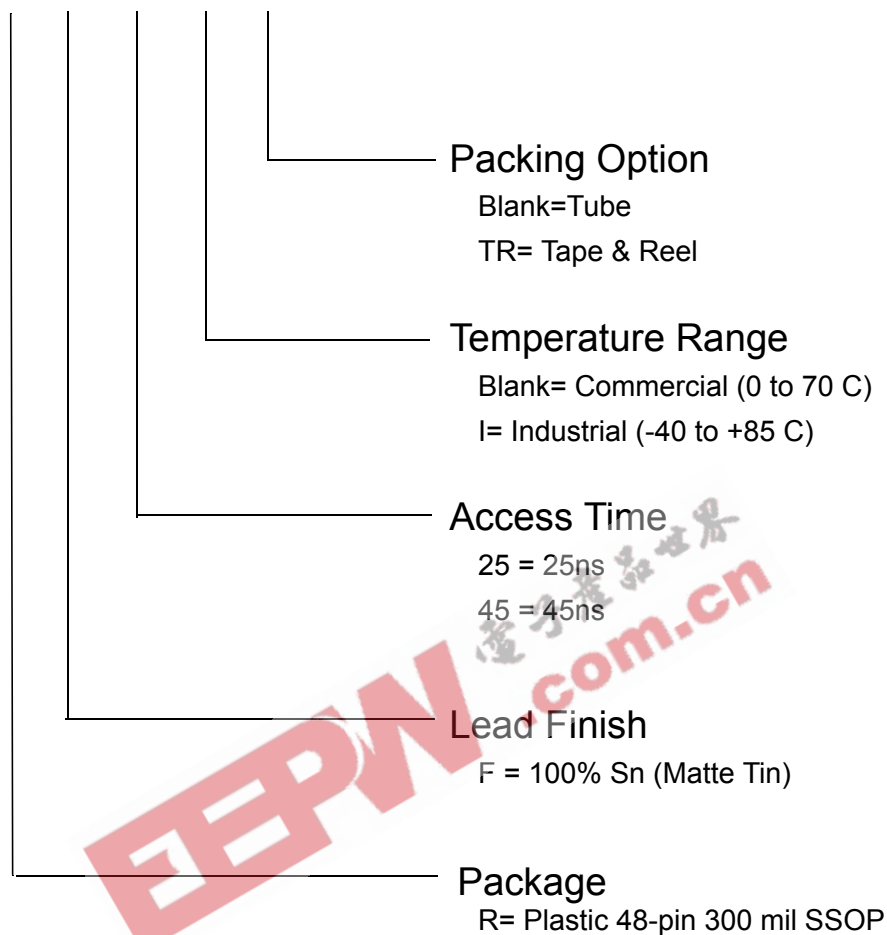

Ordering Codes

STK17T88-RF25	3.3V 32Kx8 AutoStore nvSRAM+RTC	SSOP48-300	Commercial
STK17T88-RF45	3.3V 32Kx8 AutoStore nvSRAM+RTC	SSOP48-300	Commercial
STK17T88-RF25TR	3.3V 32Kx8 AutoStore nvSRAM+RTC	SSOP48-300	Commercial
STK17T88-RF45TR	3.3V 32Kx8 AutoStore nvSRAM+RTC	SSOP48-300	Commercial
STK17T88-RF25I	3.3V 32Kx8 AutoStore nvSRAM+RTC	SSOP48-300	Industrial
STK17T88-RF45I	3.3V 32Kx8 AutoStore nvSRAM+RTC	SSOP48-300	Industrial
STK17T88-RF25ITR	3.3V 32Kx8 AutoStore nvSRAM+RTC	SSOP48-300	Industrial
STK17T88-RF45ITR	3.3V 32Kx8 AutoStore nvSRAM+RTC	SSOP48-300	Industrial

Package Drawing

48 Pin SSOP

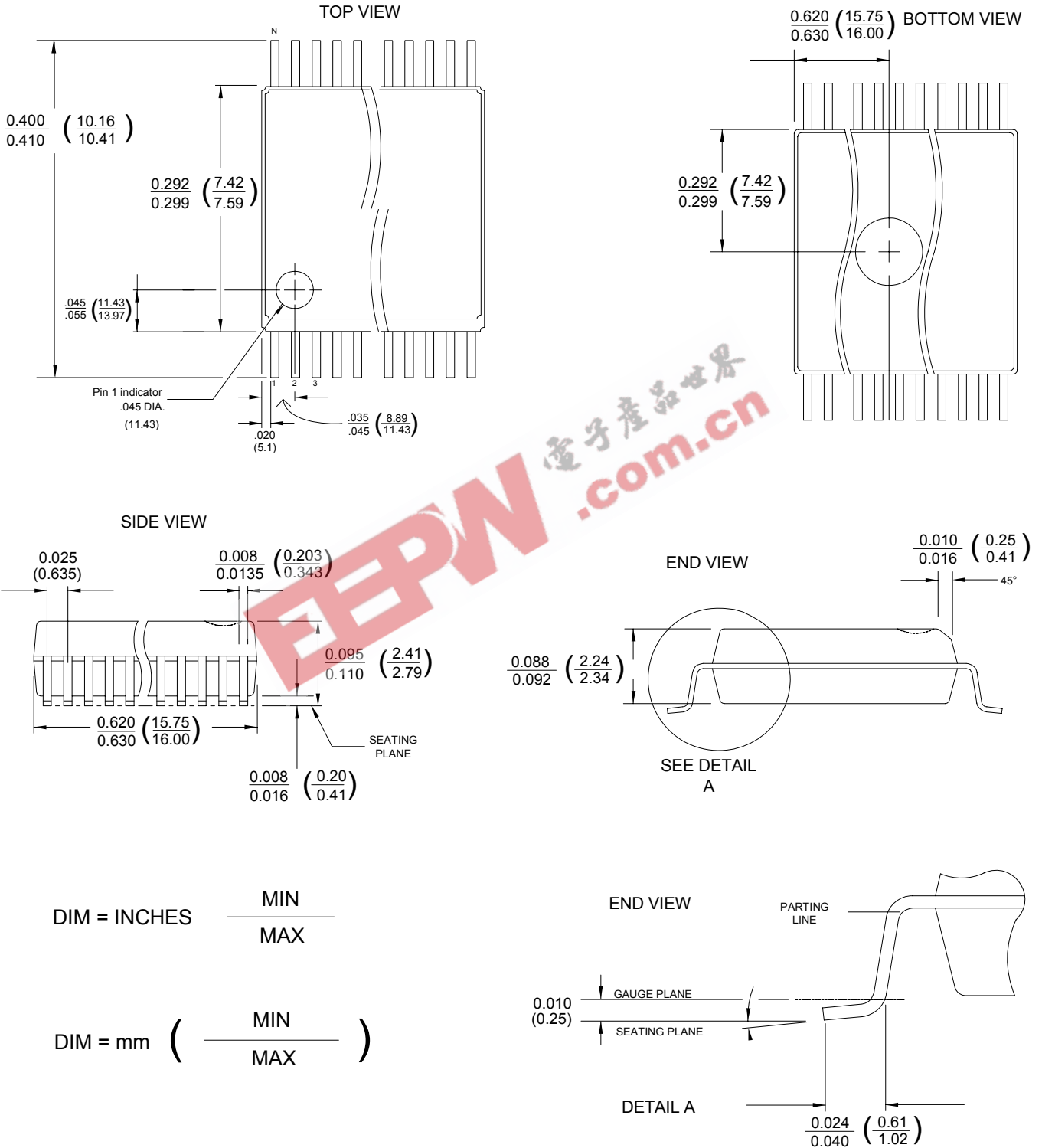

Document Revision History

Rev	Date	Change																																																												
0.0	February 2003	Publish new data sheet																																																												
0.1	March 2003	Remove 525 mil SOIC, add 48 pin SSOP and 40 pin DIP packages. Modified block diagram in AutoStore description section.																																																												
1.0	December 2004	<table border="1"> <thead> <tr> <th>Parameter</th> <th>Old Value</th> <th>New Value</th> <th>Notes</th> </tr> </thead> <tbody> <tr> <td>Vcap Min</td> <td>10 μF</td> <td>17 μF</td> <td></td> </tr> <tr> <td>t_{VCCRISE}</td> <td>NA</td> <td>150 μs</td> <td>New Spec</td> </tr> <tr> <td>I_{CC1} Max Com.</td> <td>35 mA</td> <td>50 mA</td> <td>@ 45 ns access</td> </tr> <tr> <td>I_{CC1} Max Com.</td> <td>40 mA</td> <td>55 mA</td> <td>@ 35 ns access</td> </tr> <tr> <td>I_{CC1} Max Com.</td> <td>50 mA</td> <td>65 mA</td> <td>@ 25 ns access</td> </tr> <tr> <td>I_{CC1} Max Ind.</td> <td>35 mA</td> <td>55 mA</td> <td>@ 45 ns access</td> </tr> <tr> <td>I_{CC1} Max Ind.</td> <td>45 mA</td> <td>60 mA</td> <td>@ 35 ns access</td> </tr> <tr> <td>I_{CC1} Max Ind.</td> <td>55 mA</td> <td>70 mA</td> <td>@ 25 ns access</td> </tr> <tr> <td>I_{CC1} Max</td> <td>1.5 mA</td> <td>3.0 m</td> <td>Com. & Ind.</td> </tr> <tr> <td>I_{CC1} Max</td> <td>0.5 mA</td> <td>3 mA</td> <td>Com. & Ind.</td> </tr> <tr> <td>t_{HRECALL}</td> <td>5 ms</td> <td>20 ms</td> <td></td> </tr> <tr> <td>t_{STORE}</td> <td>10 ms</td> <td>12.5 ms</td> <td></td> </tr> <tr> <td>t_{RECALL}</td> <td>20 μs</td> <td>40 μs</td> <td></td> </tr> <tr> <td>t_{GLQV}</td> <td>10 μs</td> <td>12 μs</td> <td>@ 25 ns access</td> </tr> </tbody> </table>	Parameter	Old Value	New Value	Notes	Vcap Min	10 μ F	17 μ F		t _{VCCRISE}	NA	150 μ s	New Spec	I _{CC1} Max Com.	35 mA	50 mA	@ 45 ns access	I _{CC1} Max Com.	40 mA	55 mA	@ 35 ns access	I _{CC1} Max Com.	50 mA	65 mA	@ 25 ns access	I _{CC1} Max Ind.	35 mA	55 mA	@ 45 ns access	I _{CC1} Max Ind.	45 mA	60 mA	@ 35 ns access	I _{CC1} Max Ind.	55 mA	70 mA	@ 25 ns access	I _{CC1} Max	1.5 mA	3.0 m	Com. & Ind.	I _{CC1} Max	0.5 mA	3 mA	Com. & Ind.	t _{HRECALL}	5 ms	20 ms		t _{STORE}	10 ms	12.5 ms		t _{RECALL}	20 μ s	40 μ s		t _{GLQV}	10 μ s	12 μ s	@ 25 ns access
Parameter	Old Value	New Value	Notes																																																											
Vcap Min	10 μ F	17 μ F																																																												
t _{VCCRISE}	NA	150 μ s	New Spec																																																											
I _{CC1} Max Com.	35 mA	50 mA	@ 45 ns access																																																											
I _{CC1} Max Com.	40 mA	55 mA	@ 35 ns access																																																											
I _{CC1} Max Com.	50 mA	65 mA	@ 25 ns access																																																											
I _{CC1} Max Ind.	35 mA	55 mA	@ 45 ns access																																																											
I _{CC1} Max Ind.	45 mA	60 mA	@ 35 ns access																																																											
I _{CC1} Max Ind.	55 mA	70 mA	@ 25 ns access																																																											
I _{CC1} Max	1.5 mA	3.0 m	Com. & Ind.																																																											
I _{CC1} Max	0.5 mA	3 mA	Com. & Ind.																																																											
t _{HRECALL}	5 ms	20 ms																																																												
t _{STORE}	10 ms	12.5 ms																																																												
t _{RECALL}	20 μ s	40 μ s																																																												
t _{GLQV}	10 μ s	12 μ s	@ 25 ns access																																																											
1.1	January 2005	Changed "N" package reference to "R" package.																																																												
1.2	April 2005	Changed RTC register unused bits "X" to require zero "0" value when writing values.																																																												
1.3	October 2005	<table border="1"> <thead> <tr> <th>Parameter</th> <th>Old Value</th> <th>New Value</th> <th>Notes</th> </tr> </thead> <tbody> <tr> <td>I_{CC3} Max Com.</td> <td>5 mA</td> <td>10 mA</td> <td></td> </tr> <tr> <td>I_{CC3} Max Ind.</td> <td>5 mA</td> <td>10 mA</td> <td></td> </tr> <tr> <td>ISB Max Com.</td> <td>2 mA</td> <td>3 mA</td> <td></td> </tr> <tr> <td>ISB Max Ind.</td> <td>2 mA</td> <td>3 mA</td> <td></td> </tr> <tr> <td>t_{RECALL}</td> <td>40 μa</td> <td>60 μs</td> <td>Soft Recall</td> </tr> <tr> <td>t_{STORE}</td> <td>12.5 ms</td> <td>15 ms</td> <td>Industrial Grade Only</td> </tr> <tr> <td>Max STORE Cycles</td> <td>1x10¹⁶</td> <td>5x10⁵</td> <td>Contact Simtex for details</td> </tr> <tr> <td>t_{OSCS}</td> <td>1 min</td> <td>10 sec</td> <td>@ MIN Temperature</td> </tr> <tr> <td>t_{OSCS}</td> <td>10 sec</td> <td>5 sec</td> <td>@ 25C from Power UP</td> </tr> <tr> <td>C₁</td> <td>2.2 pF</td> <td>0 pF</td> <td>RTC Output Cap</td> </tr> <tr> <td>C₂</td> <td>47 pF</td> <td>56 pF</td> <td>RTC Input Cap</td> </tr> </tbody> </table> <p>Removed plastic dip 32 pin package offering. Package type "W."</p>	Parameter	Old Value	New Value	Notes	I _{CC3} Max Com.	5 mA	10 mA		I _{CC3} Max Ind.	5 mA	10 mA		ISB Max Com.	2 mA	3 mA		ISB Max Ind.	2 mA	3 mA		t _{RECALL}	40 μ a	60 μ s	Soft Recall	t _{STORE}	12.5 ms	15 ms	Industrial Grade Only	Max STORE Cycles	1x10 ¹⁶	5x10 ⁵	Contact Simtex for details	t _{OSCS}	1 min	10 sec	@ MIN Temperature	t _{OSCS}	10 sec	5 sec	@ 25C from Power UP	C ₁	2.2 pF	0 pF	RTC Output Cap	C ₂	47 pF	56 pF	RTC Input Cap												
Parameter	Old Value	New Value	Notes																																																											
I _{CC3} Max Com.	5 mA	10 mA																																																												
I _{CC3} Max Ind.	5 mA	10 mA																																																												
ISB Max Com.	2 mA	3 mA																																																												
ISB Max Ind.	2 mA	3 mA																																																												
t _{RECALL}	40 μ a	60 μ s	Soft Recall																																																											
t _{STORE}	12.5 ms	15 ms	Industrial Grade Only																																																											
Max STORE Cycles	1x10 ¹⁶	5x10 ⁵	Contact Simtex for details																																																											
t _{OSCS}	1 min	10 sec	@ MIN Temperature																																																											
t _{OSCS}	10 sec	5 sec	@ 25C from Power UP																																																											
C ₁	2.2 pF	0 pF	RTC Output Cap																																																											
C ₂	47 pF	56 pF	RTC Input Cap																																																											
1.4	December 2005	<table border="1"> <thead> <tr> <th>Parameter</th> <th>Old Value</th> <th>New Value</th> <th>Notes</th> </tr> </thead> <tbody> <tr> <td>t_{RECALL}</td> <td>60 μs</td> <td>100 μs</td> <td>Soft Recall</td> </tr> <tr> <td>t_{SS}</td> <td>Undefined</td> <td>70 μs</td> <td>New Spec</td> </tr> <tr> <td>NV_C</td> <td>1 Million</td> <td>500K</td> <td>Nonvolatile STORE operations</td> </tr> <tr> <td>DATA_R</td> <td>100 Years at Unspecified Temperature</td> <td>20 Years at Max Temperature</td> <td>Data Retention New Specification</td> </tr> </tbody> </table> <p>Discontinued 35 ns speed grade option.</p>	Parameter	Old Value	New Value	Notes	t _{RECALL}	60 μ s	100 μ s	Soft Recall	t _{SS}	Undefined	70 μ s	New Spec	NV _C	1 Million	500K	Nonvolatile STORE operations	DATA _R	100 Years at Unspecified Temperature	20 Years at Max Temperature	Data Retention New Specification																																								
Parameter	Old Value	New Value	Notes																																																											
t _{RECALL}	60 μ s	100 μ s	Soft Recall																																																											
t _{SS}	Undefined	70 μ s	New Spec																																																											
NV _C	1 Million	500K	Nonvolatile STORE operations																																																											
DATA _R	100 Years at Unspecified Temperature	20 Years at Max Temperature	Data Retention New Specification																																																											

STK17T88

Rev	Date	Change																				
1.5	March 2006	Removed Leaded lead finish.																				
1.6	July 2006	<table border="1"> <thead> <tr> <th>Parameter</th> <th>Old Value</th> <th>New Value</th> <th>Notes</th> </tr> </thead> <tbody> <tr> <td>t_{HRE CALL}</td> <td>20 ms</td> <td>40 ms</td> <td>Power-up RECALL duration</td> </tr> <tr> <td>NV_C</td> <td>500K</td> <td>200K</td> <td>New Nonvolatile Store Cycle Spec</td> </tr> <tr> <td>DATA_R</td> <td>20 Years @ 85 C</td> <td>20 Years @ 55 C</td> <td>New Data Retention Spec</td> </tr> <tr> <td>V_{SWITCH} Min</td> <td>2.55 V</td> <td></td> <td>No Min. Spec</td> </tr> </tbody> </table>	Parameter	Old Value	New Value	Notes	t _{HRE CALL}	20 ms	40 ms	Power-up RECALL duration	NV _C	500K	200K	New Nonvolatile Store Cycle Spec	DATA _R	20 Years @ 85 C	20 Years @ 55 C	New Data Retention Spec	V _{SWITCH} Min	2.55 V		No Min. Spec
Parameter	Old Value	New Value	Notes																			
t _{HRE CALL}	20 ms	40 ms	Power-up RECALL duration																			
NV _C	500K	200K	New Nonvolatile Store Cycle Spec																			
DATA _R	20 Years @ 85 C	20 Years @ 55 C	New Data Retention Spec																			
V _{SWITCH} Min	2.55 V		No Min. Spec																			
1.7	March 2007	<p> Iout for HSB=-10uA@2.4 Volts tEHAX, tGHAX specification of 1 ns added tELAX, tGLAX specification deleted tDELAY Max specification of 70 us added tHLBL specification deleted tSS spec of 70 uS changed from min to max. ABE Bit Removed From Interrupt Register Interrupt Register Initializes to 00h Flag Bits (WDF, AF, PF) Initialize to Zero W-bit in Flag Register Enables Writes to RTC, Alarm, Calibration, Interrupt, and Flag Registers. Add Tape & Reel Ordering Option Add Product Ordering Code Listing Add Package Drawings Reformat Entire Document </p>																				

SIMTEK STK17T88 Datasheet, March 2007

Copyright 2007, Simtek Corporation. All rights reserved.

This datasheet may only be printed for the expressed use of Simtek Customers. No part of the datasheet may be reproduced in any other form or means without the express written permission from Simtek Corporation. The information contained in this publication is believed to be accurate, but changes may be made without notice. Simtek does not assume responsibility for, or grant or imply any warranty, including MERCHANTABILITY or FITNESS FOR A PARTICULAR PURPOSE regarding this information, the product or its use. Nothing herein constitutes a license, grant or transfer of any rights to any Simtek patent, copyright, trademark, or other proprietary right.