



STK20C04

CMOS nvSRAM

High Performance

512 x 8 Nonvolatile Static RAM

FEATURES

- 30, 35 and 45ns Access Times
- 15, 20 and 25ns Output Enable Access
- Unlimited Read and Write to SRAM
- Hardware STORE Initiation
- Automatic STORE Timing
- 10⁵ STORE cycles to EEPROM
- 10 year data retention in EEPROM
- Automatic RECALL on Power Up
- Hardware RECALL Initiation
- Unlimited RECALL cycles from EEPROM
- Single 5V±10% Operation
- Commercial and Industrial Temperatures
- Available in 600 mil PDIP package

DESCRIPTION

The Simtek STK20C04 is a fast static RAM (30, 35, 45ns), with a nonvolatile electrically-erasable PROM (EEPROM) element incorporated in each static memory cell. The SRAM can be read and written an unlimited number of times, while independent nonvolatile data resides in EEPROM. Data may easily be transferred from the SRAM to the EEPROM (STORE), or from the EEPROM to the SRAM (RECALL) using the \overline{NE} pin. It combines the high performance and ease of use of a fast SRAM with nonvolatile data integrity.

The STK20C04 features the industry standard pinout for nonvolatile RAMs in a 28-pin 600 mil plastic DIP.

LOGIC BLOCK DIAGRAM

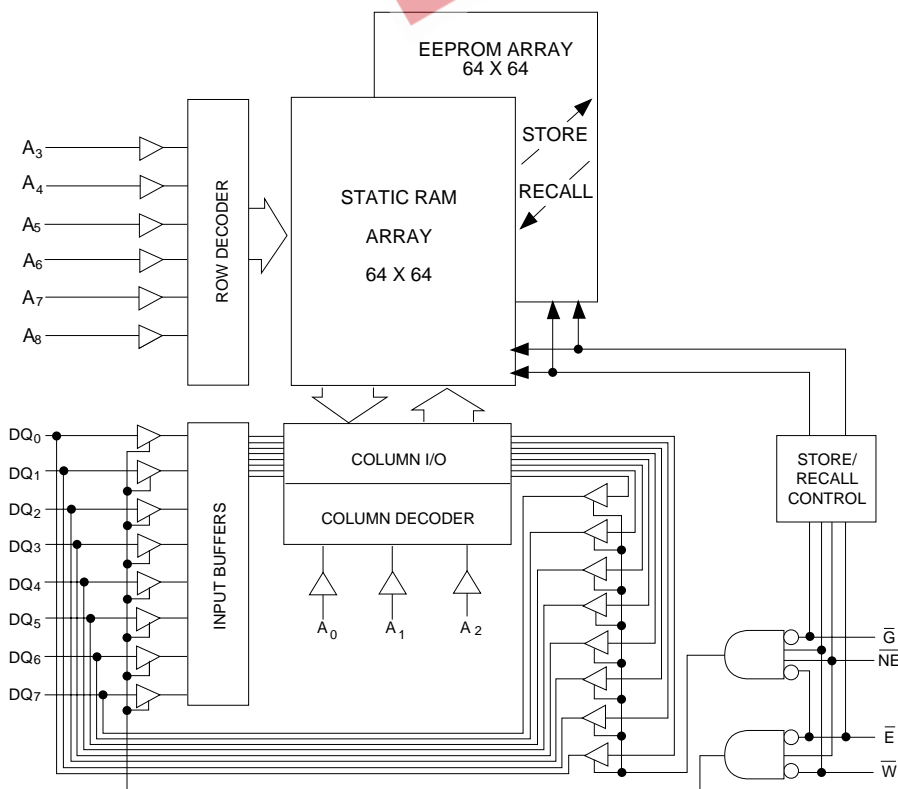

PIN CONFIGURATIONS

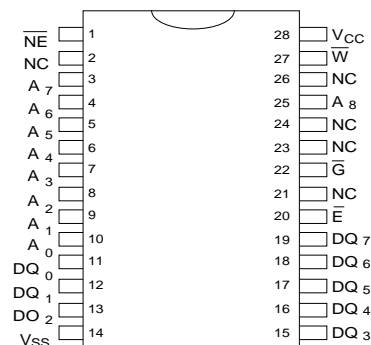

28 - 600 PDIP

PIN NAMES

Pin Name	Function
A ₀ - A ₈	Address Inputs
\overline{W}	Write Enable
DQ ₀ - DQ ₇	Data In/Out
\overline{E}	Chip Enable
\overline{G}	Output Enable
\overline{NE}	Nonvolatile Enable
V _{CC}	Power (+5V)
V _{SS}	Ground

ABSOLUTE MAXIMUM RATINGS^a

Voltage on typical input relative to V_{SS} -0.6V to 7.0V
 Voltage on DQ_{0-7} and \bar{G} -0.5V to ($V_{CC}+0.5V$)
 Temperature under bias -55°C to 125°C
 Storage temperature. -65°C to 150°C
 Power dissipation. 1W
 DC output current 15mA
 (One output at a time, one second duration)

Note a: Stresses greater than those listed under "Absolute Maximum Ratings" may cause permanent damage to the device. This is a stress rating only, and functional operation of the device at conditions above those indicated in the operational sections of this specification is not implied. Exposure to absolute maximum rating conditions for extended periods may affect reliability.

DC CHARACTERISTICS

($V_{CC} = 5.0V \pm 10\%$)

SYMBOL	PARAMETER	COMMERCIAL		INDUSTRIAL		UNITS	NOTES
		MIN	MAX	MIN	MAX		
I_{CC1}^b	Average V_{CC} Current		80		85	mA	$t_{AVAV} = 30ns$
			75		80	mA	$t_{AVAV} = 35ns$
			65		75	mA	$t_{AVAV} = 45ns$
I_{CC2}^d	Average V_{CC} Current during <i>STORE</i> cycle		50		50	mA	All inputs at $V_{IN} \leq 0.2V$ or $\geq (V_{CC} - 0.2V)$
I_{SB1}^c	Average V_{CC} Current (Standby, Cycling TTL Input Levels)		27		30	mA	$t_{AVAV} = 30ns$
			23		27	mA	$t_{AVAV} = 35ns$
			20		23	mA	$t_{AVAV} = 45ns$
I_{SB2}^c	Average V_{CC} Current (Standby, Stable CMOS Input Levels)		1		1	mA	$\bar{E} \geq V_{IH}$; all others cycling
							$\bar{E} \geq (V_{CC} - 0.2V)$ all others $V_{IN} \leq 0.2V$ or $\geq (V_{CC} - 0.2V)$
I_{ILK}	Input Leakage Current (Any Input)		± 1		± 1	μA	$V_{CC} = \max$ $V_{IN} = V_{SS}$ to V_{CC}
I_{OLK}	Off State Output Leakage Current		± 5		± 5	μA	$V_{CC} = \max$ $V_{IN} = V_{SS}$ to V_{CC}
V_{IH}	Input Logic "1" Voltage	2.2	$V_{CC}+0.5$	2.2	$V_{CC}+0.5$	V	All Inputs
V_{IL}	Input Logic "0" Voltage	$V_{SS}-0.5$	0.8	$V_{SS}-0.5$	0.8	V	All Inputs
V_{OH}	Output Logic "1" Voltage	2.4		2.4		V	$I_{OUT} = -4mA$
V_{OL}	Output Logic "0" Voltage		0.4		0.4	V	$I_{OUT} = 8mA$
T_A	Operating Temperature	0	70	-40	85	°C	

Note b: I_{CC1} is dependent on output loading and cycle rate. The specified values are obtained with outputs unloaded.

Note c: Bringing $\bar{E} \geq V_{IH}$ will not produce standby current levels until any nonvolatile cycle in progress has timed out. See MODE SELECTION table.

Note d: I_{CC2} is the average current required for the duration of the store cycle (t_{STORE}) after the sequence (t_{WC}) that initiates the cycle.

AC TEST CONDITIONS

Input Pulse Levels. V_{SS} to 3V
 Input Rise and Fall Times. $\leq 5ns$
 Input and Output Timing Reference Levels. 1.5V
 Output Load. See Figure 1

CAPACITANCE ($T_A=25^\circ C, f=1.0MHz$)^e

SYMBOL	PARAMETER	MAX	UNITS	CONDITIONS
C_{IN}	Input Capacitance	7	pF	$\Delta V = 0$ to 3V
C_{OUT}	Output Capacitance & \bar{W}	7	pF	$\Delta V = 0$ to 3V

Note e: These parameters are guaranteed but not tested.

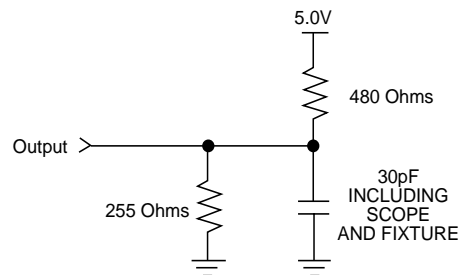

Figure 1: AC Output Loading

READ CYCLES #1 & #2

(V_{CC} = 5.0V ± 10%)

NO.	SYMBOLS		PARAMETER	STK20C04-30		STK20C04-35		STK20C04-45		UNITS
	#1, #2	Alt.		MIN	MAX	MIN	MAX	MIN	MAX	
1	t _{ELQV}	t _{ACS}	Chip Enable Access Time		30		35		45	ns
2	t _{AVAVR} ^g	t _{RC}	Read Cycle Time	30		35		45		ns
3	t _{AVQV} ^h	t _{AA}	Address Access Time		30		35		45	ns
4	t _{GLQV}	t _{OE}	Output Enable to Data Valid		15		20		25	ns
5	t _{AXQX}	t _{OH}	Output Hold After Address Change	5		5		5		ns
6	t _{ELQX}	t _{LZ}	Chip Enable to Output Active	5		5		5		ns
7	t _{EHQZ} ⁱ	t _{HZ}	Chip Disable to Output Inactive		18		20		25	ns
8	t _{GLQX}	t _{OLZ}	Output Enable to Output Active	0		0		0		ns
9	t _{GHQZ} ⁱ	t _{OHz}	Output Disable to Output Inactive		18		20		25	ns
10	t _{ELICCH} ^e	t _{PA}	Chip Enable to Power Active	0		0		0		ns
11	t _{EHICCL} ^{c,e}	t _{PS}	Chip Disable to Power Standby		25		25		25	ns
11A	t _{WHQV}	t _{WR}	Write Recovery Time		35		45		55	ns

Note c: Bringing \bar{E} high will not produce standby currents until any nonvolatile cycle in progress has timed out. See MODE SELECTION table.

Note e: Parameter guaranteed but not tested.

Note f: \bar{NE} must be high during entire cycle.

Note g: For READ CYCLE #1 and #2, \bar{W} and \bar{NE} must be high for entire cycle.

Note h: Device is continuously selected with \bar{E} low and \bar{G} low.

Note i: Measured ± 200mV from steady state output voltage.

READ CYCLE #1 f,g,h

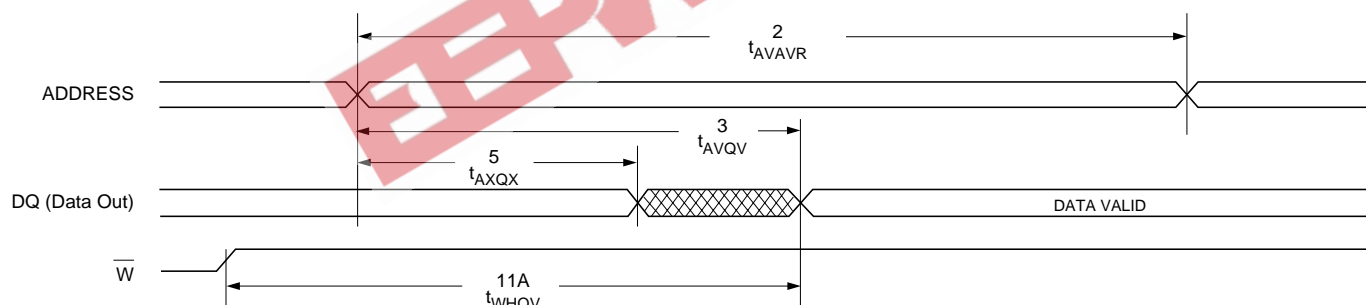

READ CYCLE #2 f,g

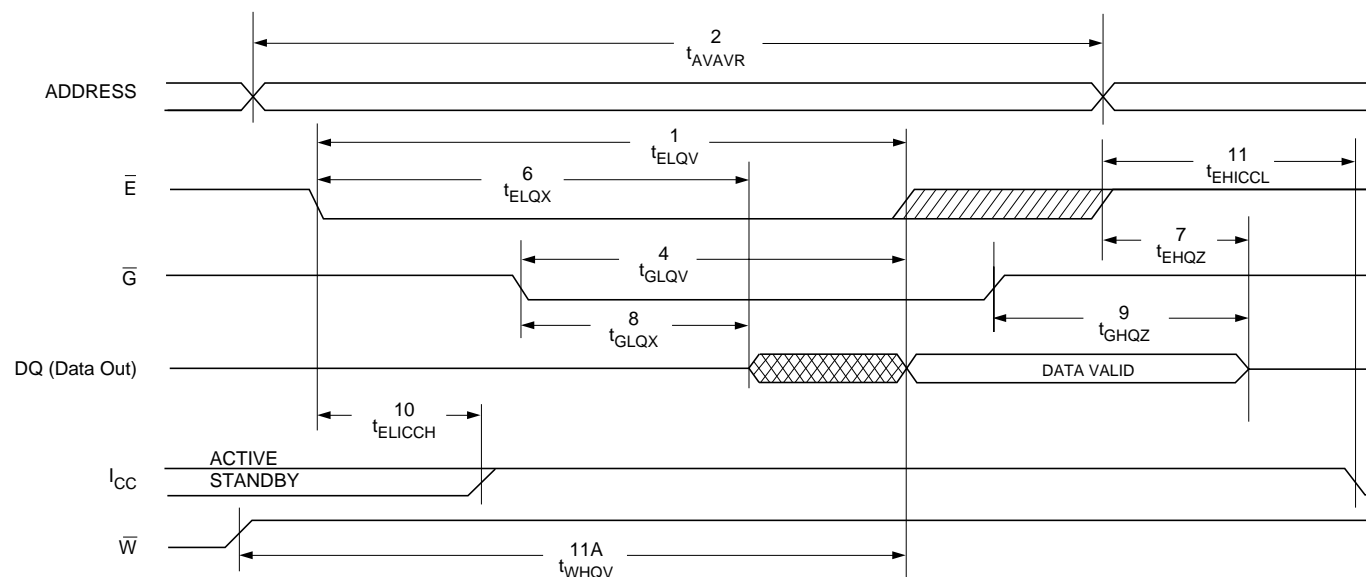

WRITE CYCLES #1 & #2

(V_{CC} = 5.0V ± 10%)

NO.	SYMBOLS			PARAMETER	STK20C04-30		STK20C04-35		STK20C04-45		UNITS
	#1	#2	#3		MIN	MAX	MIN	MAX	MIN	MAX	
12	t _{AVAVW}	t _{AVAVW}	t _{WC}	Write Cycle Time	45		45		45		ns
13	t _{WLWH}	t _{WLEH}	t _{WP}	Write Pulse Width	35		35		35		ns
14	t _{ELWH}	t _{ELEH}	t _{CW}	Chip Enable to End of Write	35		35		35		ns
15	t _{DVWH}	t _{DVEH}	t _{DW}	Data Set-up to End of Write	30		30		30		ns
16	t _{WHDX}	t _{EHDX}	t _{DH}	Data Hold After End of Write	0		0		0		ns
17	t _{AVWH}	t _{AVEH}	t _{AW}	Address Set-up to End of Write	35		35		35		ns
18	t _{AVWL}	t _{AVEL}	t _{AS}	Address Set-up to Start of Write	0		0		0		ns
19	t _{WHAX}	t _{EHAX}	t _{WR}	Address Hold After End of Write	0		0		0		ns
20	t _{WLQZ^{i,m}}		t _{WZ}	Write Enable to Output Disable		35		35		35	ns
21	t _{WHQX}		t _{OW}	Output Active After End of Write	5		5		5		ns

Note f: \overline{NE} must be high during entire cycle.

Note i: Measured ± 200mV from steady state output voltage.

Note k: \overline{E} or \overline{W} must be high during address transitions.

Note m: If \overline{W} is low when \overline{E} goes low, the outputs remain in the high impedance state.

WRITE CYCLE #1: \overline{W} CONTROLLED f,k

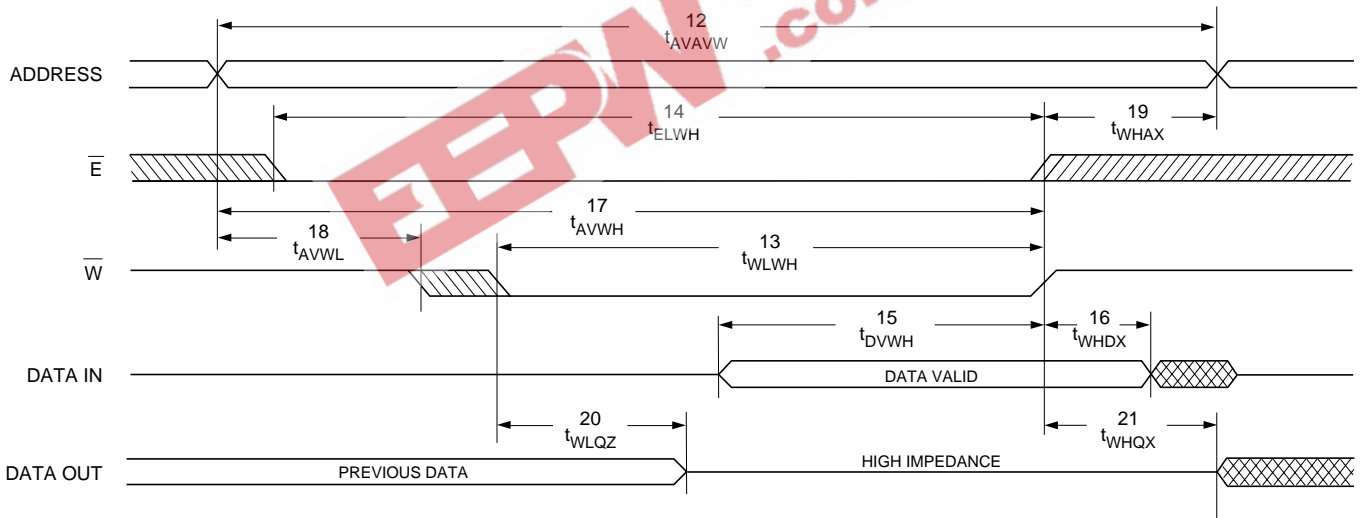

WRITE CYCLE #2: \overline{E} CONTROLLED f,k

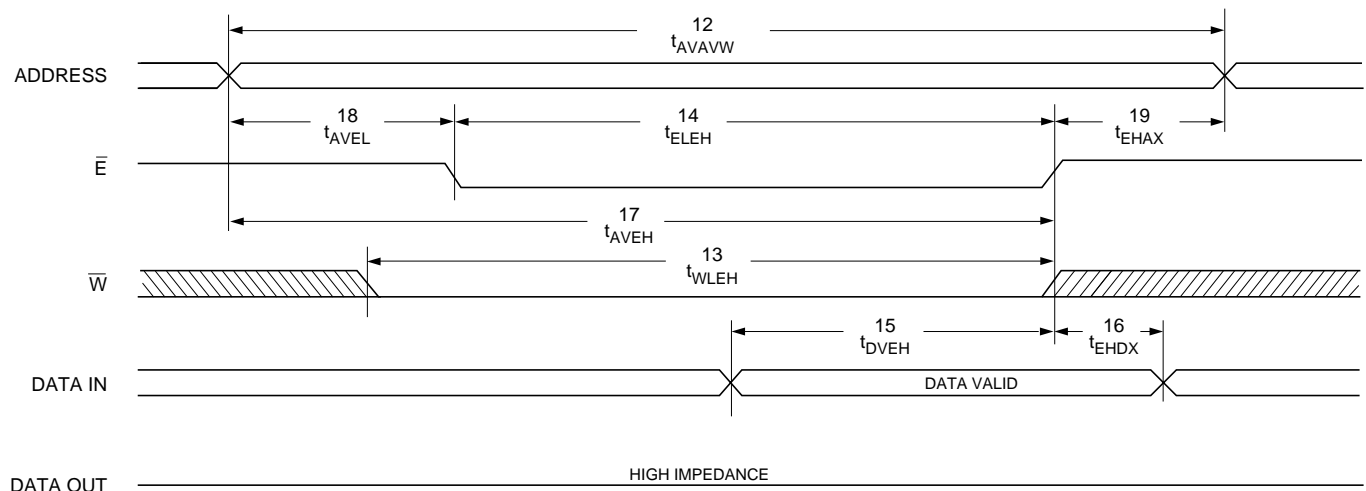

NONVOLATILE MEMORY OPERATION

MODE SELECTION

\bar{E}	\bar{W}	\bar{G}	\bar{NE}	MODE	POWER
H	X	X	X	Not Selected	Standby
L	H	L	H	Read RAM	Active
L	L	X	H	Write RAM	Active
L	H	L	L	Nonvolatile <i>RECALL</i> ⁿ	Active
L	L	H	L	Nonvolatile <i>STORE</i>	I_{CC2}
L	L	L	L	No operation	Active
L	H	H	X		

STORE CYCLES #1 & #2

($V_{CC} = 5.0V \pm 10\%$)

NO.	SYMBOLS			PARAMETER	MIN	MAX	UNITS
	#1	#2	Alt.				
22	t_{WLQX}^p	t_{ELQXS}	t_{STORE}	STORE Cycle Time		10	ms
23	t_{WLNH}^q	t_{ELNHS}	t_{WC}	STORE Initiation Cycle Time	45		ns
24	t_{GHNL}			Output Disable Set-up to \bar{NE} Fall	0		ns
25		t_{GHLE}		Output Disable Set-up to \bar{E} Fall	0		ns
26	t_{NLWL}	t_{NLEL}		\bar{NE} Set-up	0		ns
27	t_{ELWL}			Chip Enable Set-up	0		ns
28		t_{WLEL}		Write Enable Set-up	0		ns

Note n: An automatic *RECALL* also takes place at power up, starting when V_{CC} exceeds 3.8V, and taking t_{RECALL} from the time at which V_{CC} exceeds 4.5V. V_{CC} must not drop below 3.8V once it has exceeded it for the *RECALL* to function properly.

Note o: If \bar{E} is low for any period of time in which \bar{W} is high while \bar{G} and \bar{NE} are low, then a *RECALL* cycle may be initiated.

Note p: Measured with \bar{W} and \bar{NE} both returned high, and \bar{G} returned low. Note that *STORE* cycles are inhibited/aborted by $V_{CC} < 3.8V$ (*STORE* inhibit).

Note q: Once t_{WC} has been satisfied by \bar{NE} , \bar{G} , \bar{W} and \bar{E} , the *STORE* cycle is completed automatically. Any of \bar{NE} , \bar{G} , \bar{W} or \bar{E} may be used to terminate the *STORE* initiation cycle.

STORE CYCLE #1: \bar{W} CONTROLLED^o

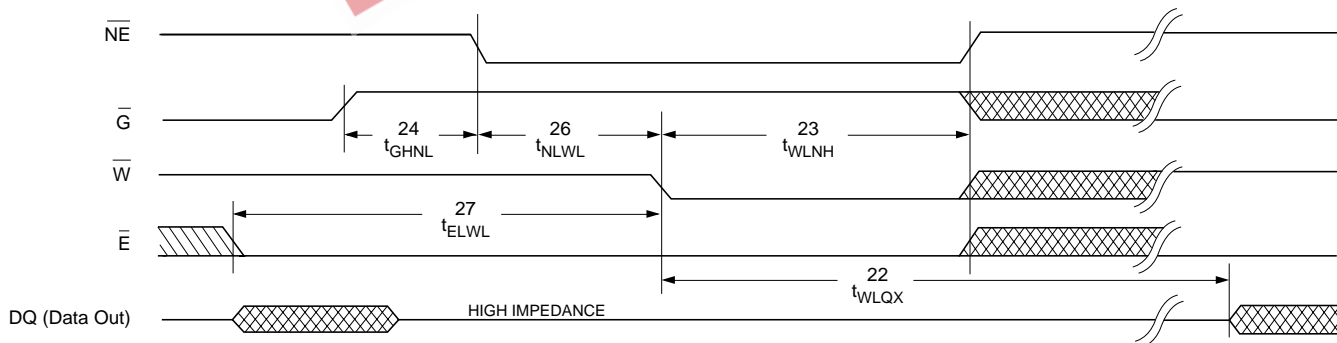

STORE CYCLE #2: \bar{E} CONTROLLED^o

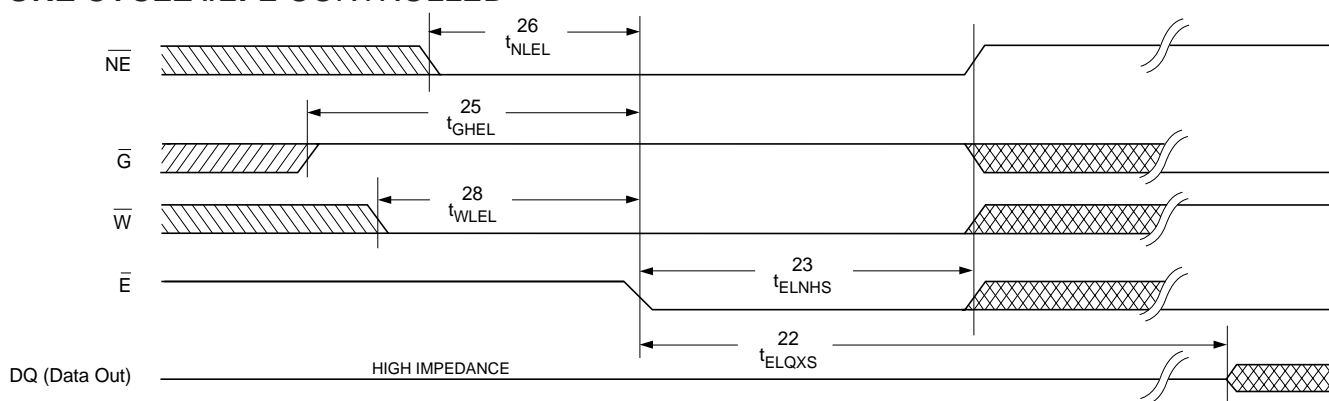

RECALL CYCLES #1, #2 & #3

(V_{CC} = 5.0V ± 10%)

NO.	SYMBOLS			PARAMETER	MIN	MAX	UNITS
	#1	#2	Alt.				
29	t _{NLQX} ^r	t _{ELQXR}	t _{GLQXR}	RECALL Cycle Time		20	μs
30	t _{NLNH} ^s	t _{ELNHR}	t _{GLNH}	RECALL Initiation Cycle Time	25		ns
31		t _{NLEL}	t _{NLGL}	\overline{NE} Set-up	0		ns
32	t _{GLNL}	t _{GLEL}		Output Enable Set-up	0		ns
33	t _{WHNL}	t _{WHEL}	t _{WHGL} ^t	Write Enable Set-up	0		ns
34	t _{ELNL}		t _{ELGL}	Chip Enable Set-up	0		ns
35	t _{NLQZ}			\overline{NE} Fall to Outputs Inactive		25	

ns
 Note r: Measured with \overline{W} and \overline{NE} both high, and \overline{G} and \overline{E} low.
 Note s: Once t_{NLNH} has been satisfied by \overline{NE} , \overline{G} , \overline{W} and \overline{E} , the RECALL cycle is completed automatically. Any of \overline{NE} , \overline{G} or \overline{E} may be used to terminate the RECALL initiation cycle.
 Note t: If \overline{W} is low at any point in which both \overline{E} and \overline{NE} are low and \overline{G} is high, then a STORE cycle will be initiated instead of a RECALL.

RECALL CYCLE #1: \overline{NE} CONTROLLED^o

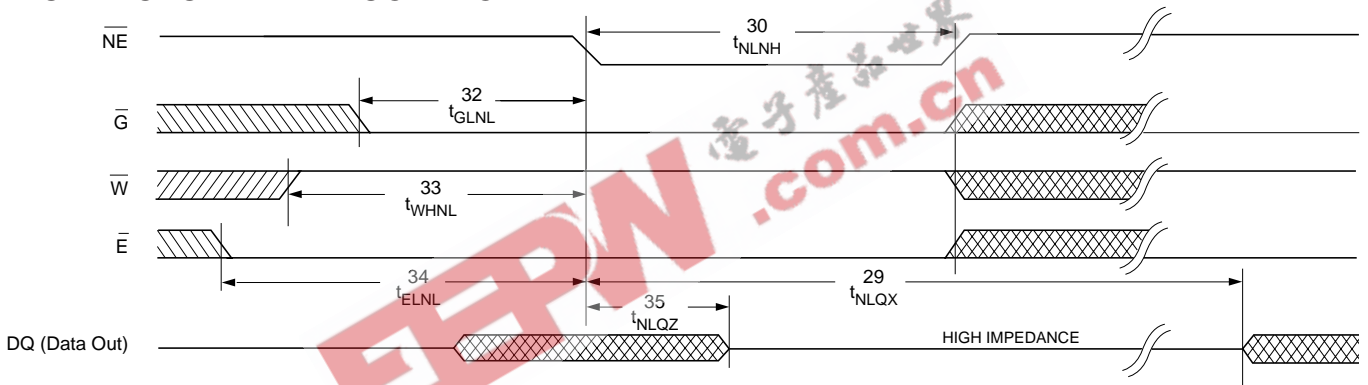

RECALL CYCLE #2: \overline{E} CONTROLLED^o

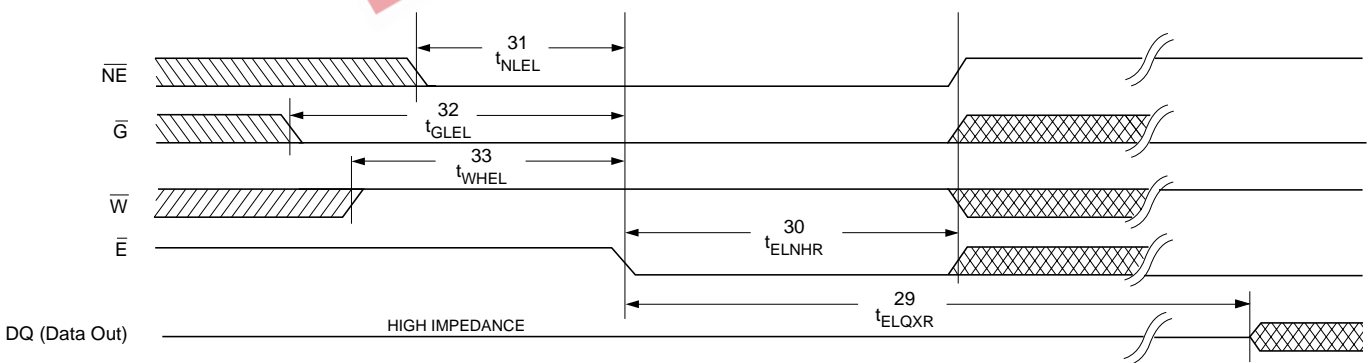

RECALL CYCLE #3: \overline{G} CONTROLLED^{o,t}

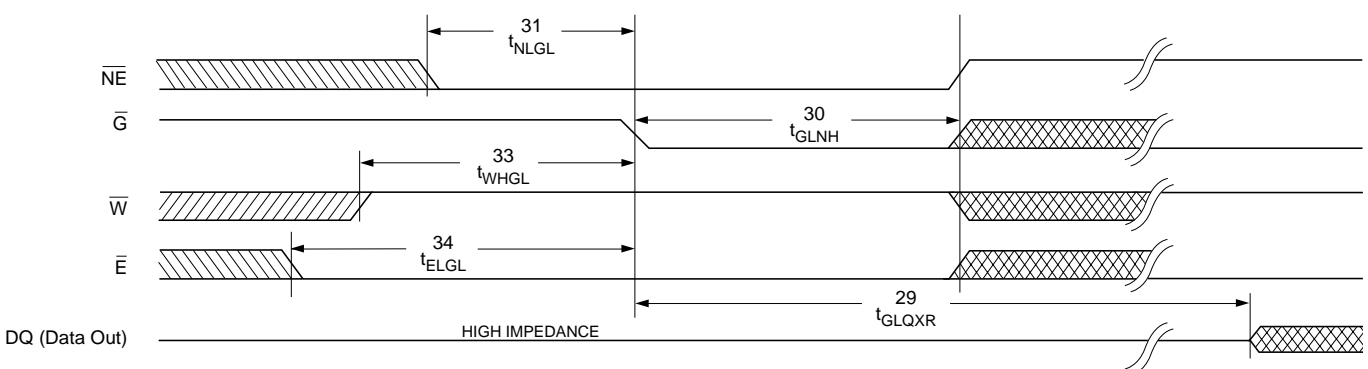

DEVICE OPERATION

The STK20C04 has two modes of operation: SRAM mode and nonvolatile mode, determined by the state of the \overline{NE} pin. When in SRAM mode, the memory operates as an ordinary static RAM. While in nonvolatile mode, data is transferred in parallel from SRAM to EEPROM or from EEPROM to SRAM.

SRAM READ

The STK20C04 performs a READ cycle whenever \overline{E} and \overline{G} are LOW and \overline{NE} and \overline{W} are HIGH. The address specified on pins A_{0-8} determines which of the 512 data bytes will be accessed. When the READ is initiated by an address transition, the outputs will be valid after a delay of t_{AVQV} (READ CYCLE #1). If the READ is initiated by \overline{E} or \overline{G} , the outputs will be valid at t_{ELQV} or at t_{GLQV} whichever is later (READ CYCLE #2). The data outputs will repeatedly respond to address changes within the t_{AVQV} access time without the need for transitions on any control input pins, and will remain valid until another address change or until \overline{E} or \overline{G} is brought HIGH or \overline{W} or \overline{NE} is brought LOW.

SRAM WRITE

A write cycle is performed whenever \overline{E} and \overline{W} are LOW and \overline{NE} is HIGH. The address inputs must be stable prior to entering the WRITE cycle and must remain stable until either \overline{E} or \overline{W} go HIGH at the end of the cycle. The data on pins DQ_{0-7} will be written into the memory if it is valid t_{DVWH} before the end of a \overline{W} controlled WRITE or t_{DVEH} before the end of an \overline{E} controlled WRITE.

It is recommended that \overline{G} be kept HIGH during the entire WRITE cycle to avoid data bus contention on common I/O lines. If \overline{G} is left LOW, internal circuitry will turn off the output buffers t_{WLQZ} after \overline{W} goes LOW.

NONVOLATILE STORE

A STORE cycle is performed when \overline{NE} , \overline{E} and \overline{W} are LOW and \overline{G} is HIGH. While any sequence to achieve this state will initiate a STORE, only \overline{W} initiation (STORE CYCLE #1) and \overline{E} initiation (STORE CYCLE #2) are practical without risking an unintentional SRAM WRITE that would disturb SRAM data. During a STORE cycle, previous nonvolatile data is erased and the SRAM contents are then programmed into nonvolatile elements. Once a STORE cycle is initiated, further input

and output is disabled and the DQ_{0-7} pins are tri-stated until the cycle is completed.

If \overline{E} and \overline{G} are LOW and \overline{W} and \overline{NE} are HIGH at the end of the cycle, a READ will be performed and the outputs will go active, signaling the end of the STORE.

HARDWARE PROTECT

The STK20C04 offers two levels of protection to suppress inadvertent STORE cycles. If the control signals (\overline{E} , \overline{G} , \overline{W} , and \overline{NE}) remain in the STORE condition at the end of a STORE cycle, a second STORE cycle will *not* be started. The STORE (or RECALL) will be initiated only after a transition on any one of these signals to the required state. In addition to multi-trigger protection, the STK20C04 offers hardware protection through V_{CC} Sense. A STORE cycle will not be initiated, and one in progress will discontinue if V_{CC} goes below 3.8V. 3.8V is a typical, characterized value.

NONVOLATILE RECALL

A RECALL cycle is performed when \overline{E} , \overline{G} , and \overline{NE} are LOW and \overline{W} is HIGH. Like the STORE cycle, RECALL is initiated when the last of the four clock signals goes to the RECALL state. Once initiated, the RECALL cycle will take t_{NLQX} to complete, during which all inputs are ignored. When the RECALL completes, any READ or WRITE state on the input pins will take effect.

Internally, RECALL is a two step procedure. First, the SRAM data is cleared and second, the nonvolatile information is transferred into the SRAM cells. The RECALL operation in no way alters the data in the nonvolatile cells. The nonvolatile data can be recalled an unlimited number of times.

Like the STORE cycle, a transition must occur on any control pin to cause a recall, preventing inadvertent multi-triggering. On power-up, once V_{CC} exceeds the V_{CC} sense voltage of 3.8V, a RECALL cycle is automatically initiated. The voltage on the V_{CC} pin must not drop below 3.8V once it has risen above it in order for the RECALL to operate properly. Due to this automatic RECALL, SRAM operation cannot commence until t_{NLQX} after V_{CC} exceeds 3.8V. 3.8V is a typical, characterized value.

ORDERING INFORMATION

STK20C04 - W 30 I

Temperature Range

blank = Commercial (0 to 70 degrees C)

I = Industrial (-40 to 85 degrees C)

Access Time

30 = 30ns

35 = 35ns

45 = 45ns

Package

W = Plastic 28 pin 600 mil DIP

