

SRAM

32K X 8 LOW POWER CMOS STATIC RAM

FEATURES

- High speed access time: 50/70/85/100ns
- Power supply current : Operating :35mA(max)
Standby : 5uA
- Power supply : 2.4V to 3.6V
- Fully static operation – No clock or refreshing required
- All inputs and outputs directly LVTTTL compatible
- Common I/O capability
- Data retention voltage : 1.5V (min)
- Available packages :28-pin SOP ,TSOP-I (8x13.4mm forward type and reverse type).
- Operating temperature :
 - 0 ~ +70 °C
 - -40 ~ +85 °C

PART NUMBER EXAMPLES

PART NO.	PACKAGE CODE	Operating Temperature
T15V256A-70D	D=SOP	0 ~ +70 °C
T15V256A-85P	P= TSOP-I(Forward)	
T15V256A-85R	R= TSOP-I(Reverse)	
T15V256A-70DI	D=SOP	-40 ~ +85 °C
T15V256A-85PI	P= TSOP-I(Forward)	
T15V256A-85RI	R= TSOP-I(Reverse)	

GENERAL DESCRIPTION

The T15V256A is a low power and low voltage CMOS static RAM. organized as 32,768 x 8 bits that operates on a 2.4V to 3.6V power supply. Data retention is guaranteed at a power supply voltage as low as 1.5V. This device is packaged in a standard 28-pin SOP or TSOP-I forward and reverse type.

BLOCK DIAGRAM

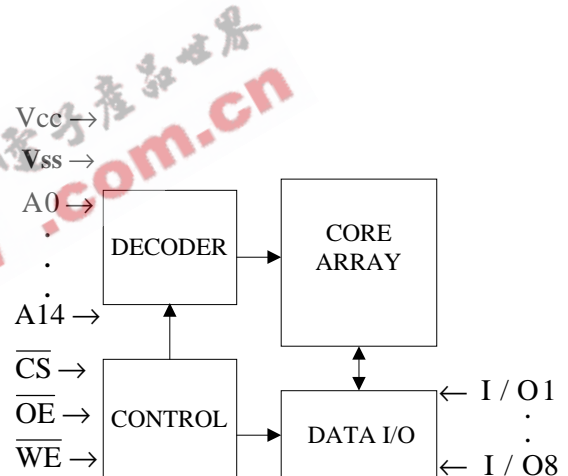

PIN CONFIGURATION

(Top View)

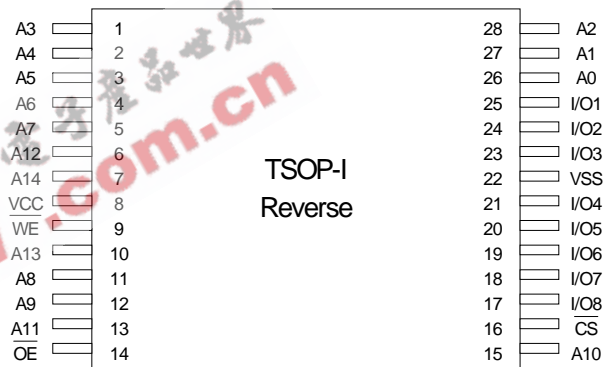
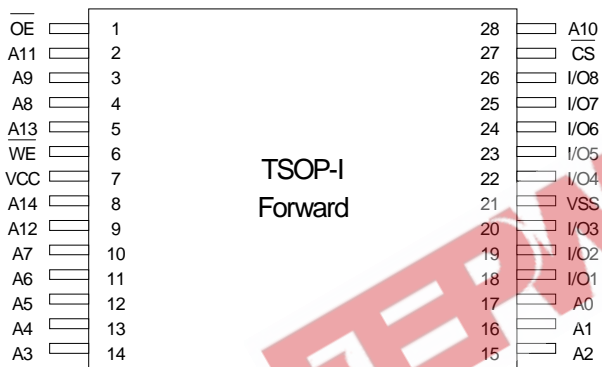
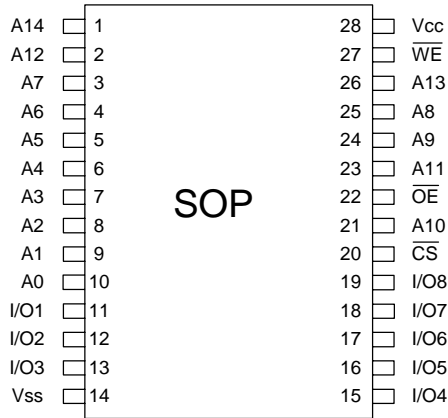

PIN DESCRIPTION

SYMBOL	DESCRIPTION
A0 - A14	Address Inputs
I/O1 - I/O8	Data Inputs/Outputs
CS	Chip Select Inputs
WE	Write Enable
OE	Output Enable
Vcc	Power Supply
Vss	Ground

DC CHARACTERISTICS ABSOLUTE MAXIMUM RATINGS

PARAMETER	RATING	UNIT
Supply Voltage to Vss Potential	-0.5 to + 4.6	V
Inputs to Vss Potential	-0.5 to Vcc +0.5	V
Power Dissipation	0.7	W
Storage Temperature	-60 to +150	°C

RECOMMENDED OPERATING CONDITIONS

PARAMETER	SYM	MIN	TYP	MAX	UNIT
Supply Voltage	Vcc	2.4	-	3.6	V
Input Voltage, low	V _{IL}	-0.3	-	0.6	V
Input Voltage, high	V _{IH}	0.7Vcc	-	Vcc+0.3	V
Ambient Temperature	T _A	0/-40	-	+75/+85	°C

TRUTH TABLE

CS	OE	WE	MODE	I/O1- I/O8	Power
H	X	X	Not Selected	High-Z	Standby
L	H	H	Output Disable	High-Z	Active
L	L	H	Read	Data Out	Active
L	X	L	Write	Data In	Active

OPERATING CHARACTERISTICS

(Vcc = 2.4V to 3.6V, Vss = 0V, Ta = 0 ~ +70 °C /-40 to 85°C)

PARAMETER	SYM.	TEST CONDITIONS	MIN.	TYP.	MAX.	UNIT	
Input Leakage Current	I _{LI}	Vin=Vss to Vcc	-	-	1	μA	
Output Leakage Current	I _{LO}	V _{I/O} =Vss to Vcc, CS = V _{IH} or OE= V _{IH} or WE = V _{IL}	-	-	1	μA	
Output Low Voltage	V _{OL}	I _{OL} = + 2.1mA	-	-	0.4	V	
Output High Voltage	V _{OH}	I _{OH} = - 1.0mA	2.1	-	-	V	
Operating Power Supply Current	I _{cc}	CS = V _{IL} , I/O=0mA Cycle = MIN. Duty = 100%	-50	-	-	35	mA
			-70	-	-	30	mA
			-85	-	-	25	mA
			-100	-	-	20	mA
Standby Power Supply Current	I _{SB}	CS = V _{IH} , Cycle=min, Duty=100%	-	-	0.3	mA	
	I _{SBI}	CS ≥ V _{cc} -0.2V	-	-	5	uA	

CAPACITANCE

(V_{CC} = 2.4V to 3.6V, T_a = 25°C, f = 1 MHz)

PARAMETER	SYMBOL	CONDITION	MAX.	UNIT
Input Capacitance	C _{IN}	V _{IN} = 0V	6	pF
Input/ Output Capacitance	C _{I/O}	V _{OUT} = 0V	8	pF

Note: These parameters are sampled but not 100% tested.

AC TEST CONDITIONS

PARAMETER	CONDITIONS
Input Pulse Levels	0.6V to 0.7V _{CC}
Input Rise and Fall Times	3 ns
Input and Output Timing Reference Level	1.4V
Output Load	See Fig. 1,2

AC TEST LOADS AND WAVEFORM

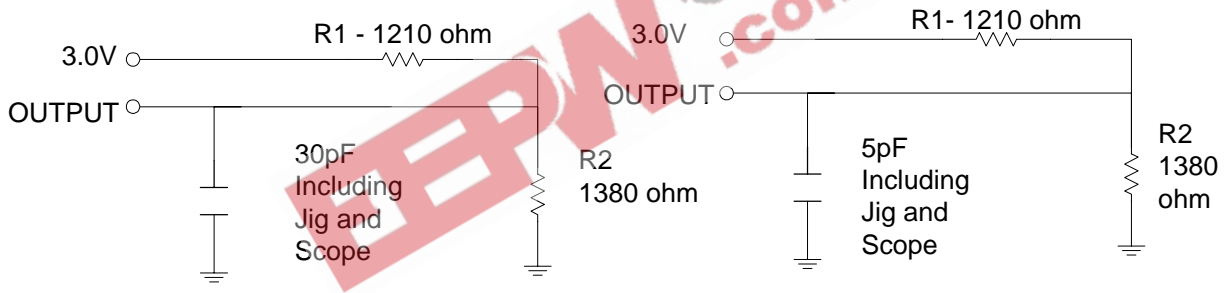

(For T_{CLZ}, T_{OLZ}, T_{CHZ}, T_{OHZ}, T_{WHZ}, T_{OW})

Fig 1

Fig 2

AC CHARACTERISTICS

 (V_{CC}=2.4V to 3.6V, V_{SS} = 0V, Ta = 0 ~ +70 °C /-40 to 85°C)

(1) READ CYCLE

PARAMETER	SYM.	-50ns		-70ns		-85ns		-100ns		UNIT
		MIN	MAX	MIN.	MAX.	MIN.	MAX.	MIN.	MAX.	
Read Cycle Time	tRC	50	-	70	-	85	-	100	-	ns
Address Access Time	tAA	-	50	-	70	-	85	-	100	ns
Chip Select Access Time	tACS	-	50	-	70	-	85	-	100	ns
Output Enable to Output Valid	tAOE	-	25	-	35	-	40	-	50	ns
Chip Selection to Output in Low Z	tCLZ*	7	-	10	-	10	-	10	-	ns
Output Enable to Output in Low Z	tOLZ*	5	-	5	-	5	-	5	-	ns
Chip Deselection to Output in High Z	tCHZ*	-	20	-	25	-	30	-	30	ns
Output Disable to Output in High Z	tOHZ*	-	20	-	25	-	30	-	30	ns
Output Hold from Address Change	tOH	10	-	10	-	10	-	10	-	ns

* These parameters is measured with 5pF test load.

(2)WRITE CYCLE

PARAMETER	SYM.	-50ns		-70ns		-85ns		-100ns		UNIT
		MIN	MAX	MIN.	MAX.	MIN.	MAX.	MIN.	MAX.	
Write Cycle Time	tWC	50	-	70	-	85	-	100	-	ns
Chip Selection to End of Write	tCW	40	-	60	-	70	-	80	-	ns
Address Valid to End of Write	tAW	40	-	60	-	70	-	80	-	ns
Address Setup Time	tAS	0	-	0	-	0	-	0	-	ns
Write Pulse Width	tWP	30	-	50	-	60	-	70	-	ns
Write Recovery Time	tWR	0	-	0	-	0	-	0	-	ns
Data Valid to End of Write	tDW	25	-	30	-	35	-	40	-	ns
Data Hold from End of Write	tDH	0	-	0	-	0	-	0	-	ns
Write to Output in High Z	tWHZ*	-	20	-	25	-	30	-	30	ns
Output Active from End of Write	tOW	5	-	5	-	5	-	5	-	ns

* These parameters is measured with 5pF test load.

DATA RETENTION CHARACTERISTICS

Item	Symbol	Test Condition	Min	Typ	max	unit
Vcc for data retention	V _{DR}	$\overline{CS} \geq V_{CC}-0.2V$	1.5	-	3.6	V
Data retention current	I _{DR}	$V_{CC}=3.0, \overline{CS} \geq V_{CC}-0.2V$	-	-	5	uA
Data retention set-up time	t _{SDR}	See data retention waveform	0	-	-	ms
Recovery time	t _{RDR}		5	-	-	

DATA RETENTION WAVE FORM

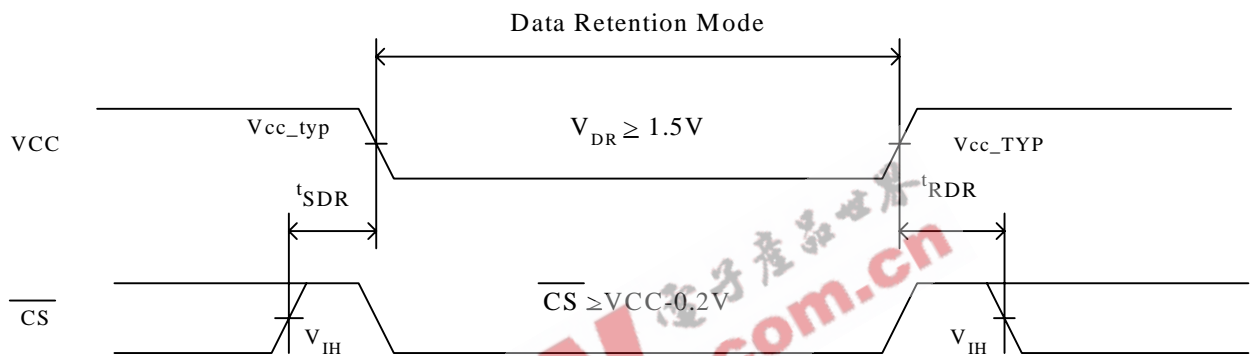

TIMING WAVEFORMS

READ CYCLE 1

(Address Controlled)

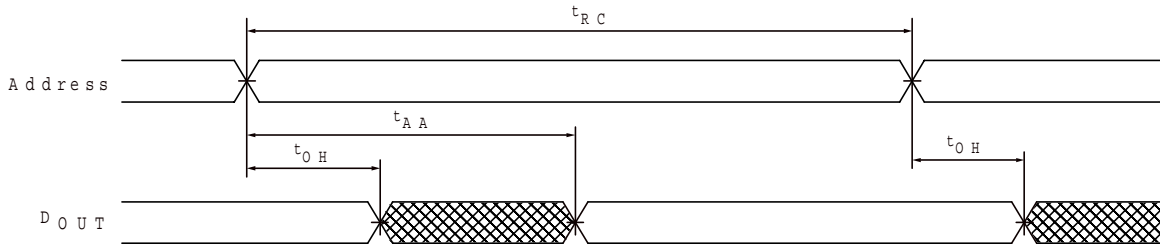

READ CYCLE 2

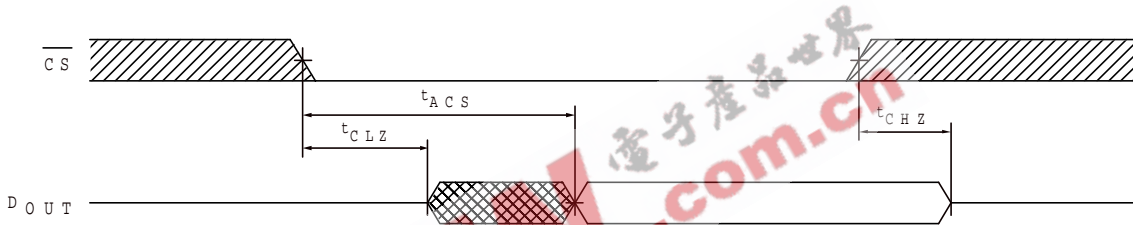

(Chip Select Controlled)

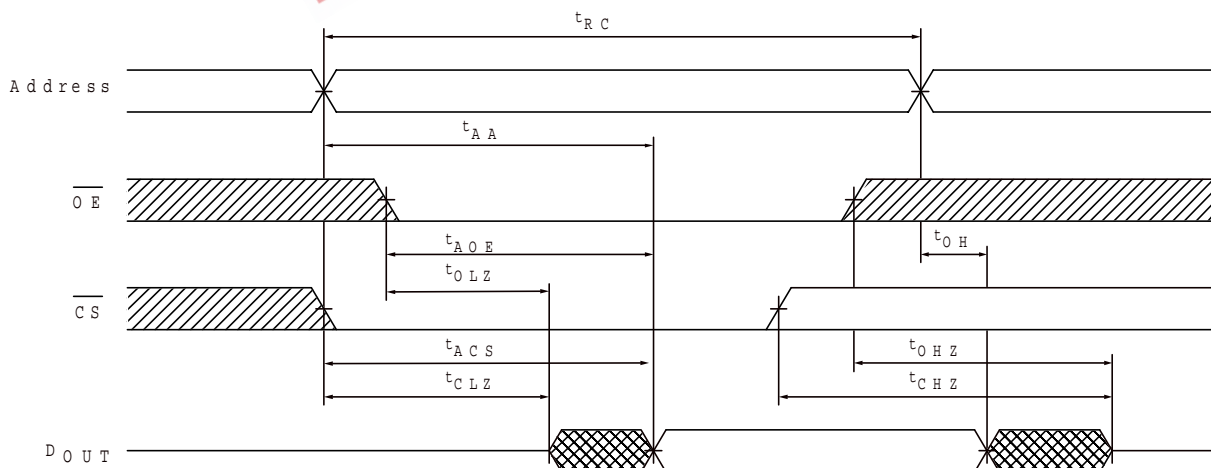

READ CYCLE 3

(Output Enable Controlled)



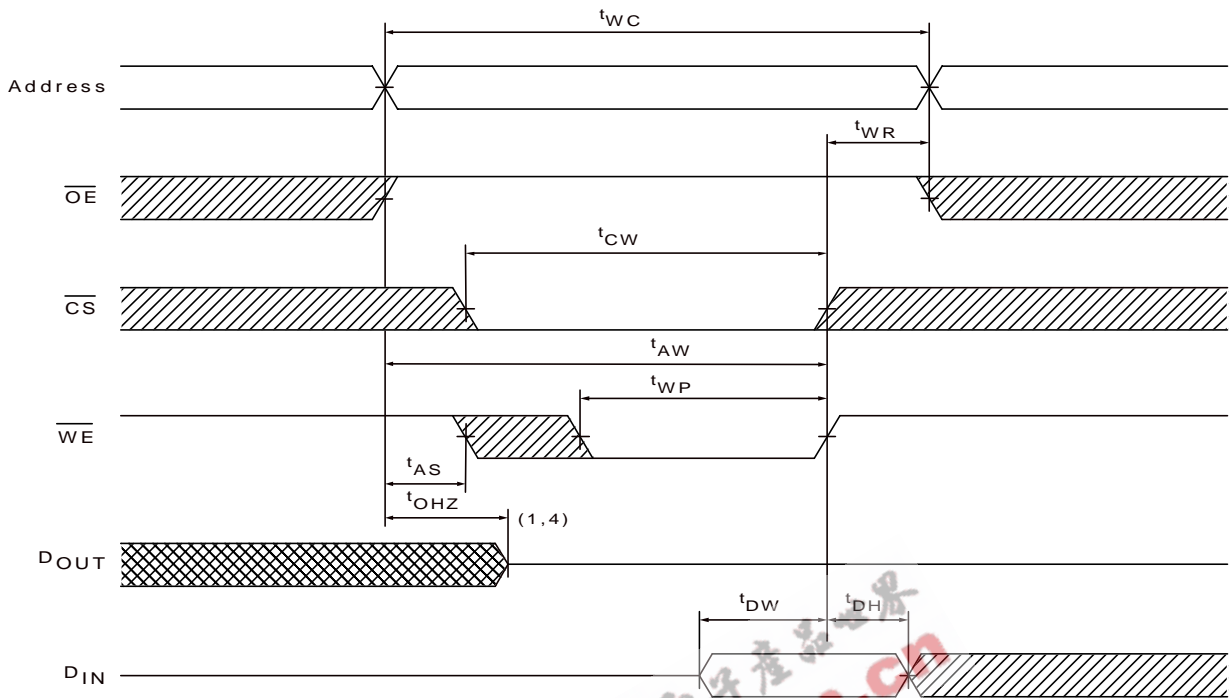

 DON'T CARE
 UNDEFINED

WRITE CYCLE 1 (\overline{OE} CLOCK)

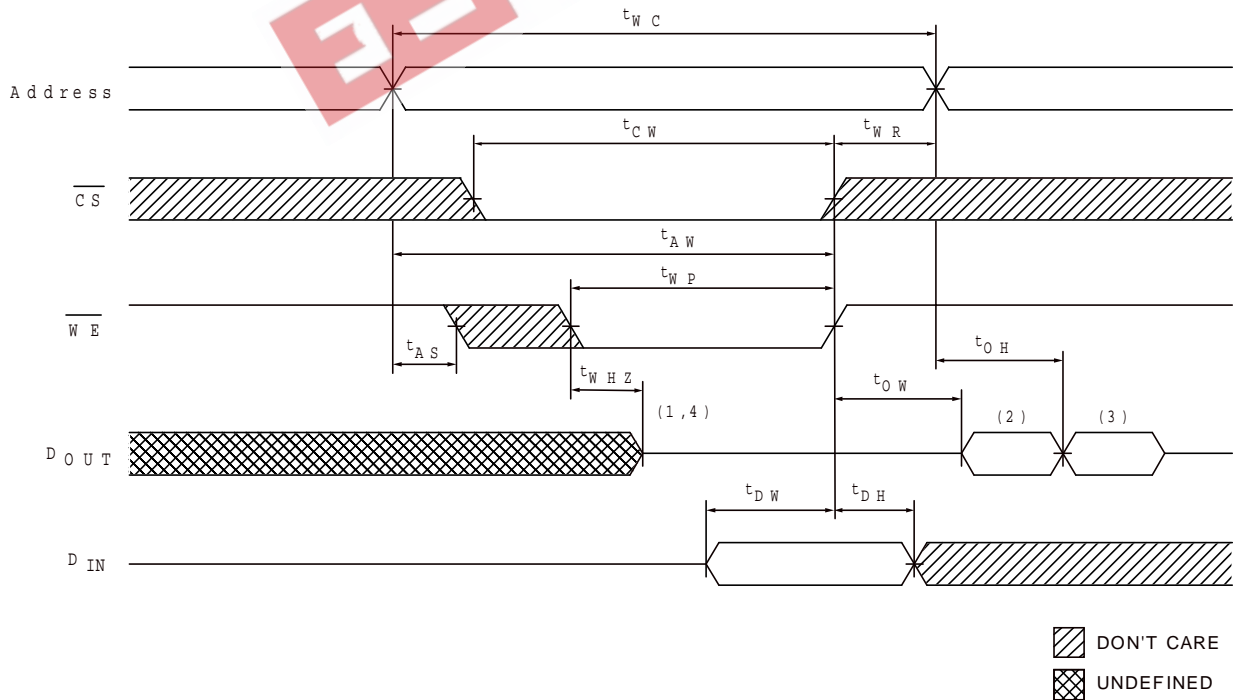

WRITE CYCLE 2 ($\overline{OE} = V_{IL}$ Fixed)



 DON'T CARE
 UNDEFINED

- Notes:
1. During this period, I/O pins are in the output state, so input signals of opposite phase to the outputs should not be applied.
 2. The data output from D_{OUT} are the same as the data written to D_{IN} during the write cycle.
 3. D_{OUT} provides the read data for the next address.
 4. Transition is measured ± 500 mV from steady state with $C_L = 5$ pF. This parameter is guaranteed but not 100% tested.
 5. If \overline{OE} is low during a \overline{WE} controlled write cycle, the write pulse width must be the larger of t_{WP} or $(t_{WHZ} + t_{DW})$ to allow the I/O drivers to turn off and data to be placed on the bus for the required t_{DW} . If \overline{OE} is high during a \overline{WE} controlled write cycle, this requirement does not apply and the write pulse can be as short as the specified t_{WP} .

EEPW 电子产品世界
.com.cn

PACKAGE DIMENSIONS

28-LEAD SOP

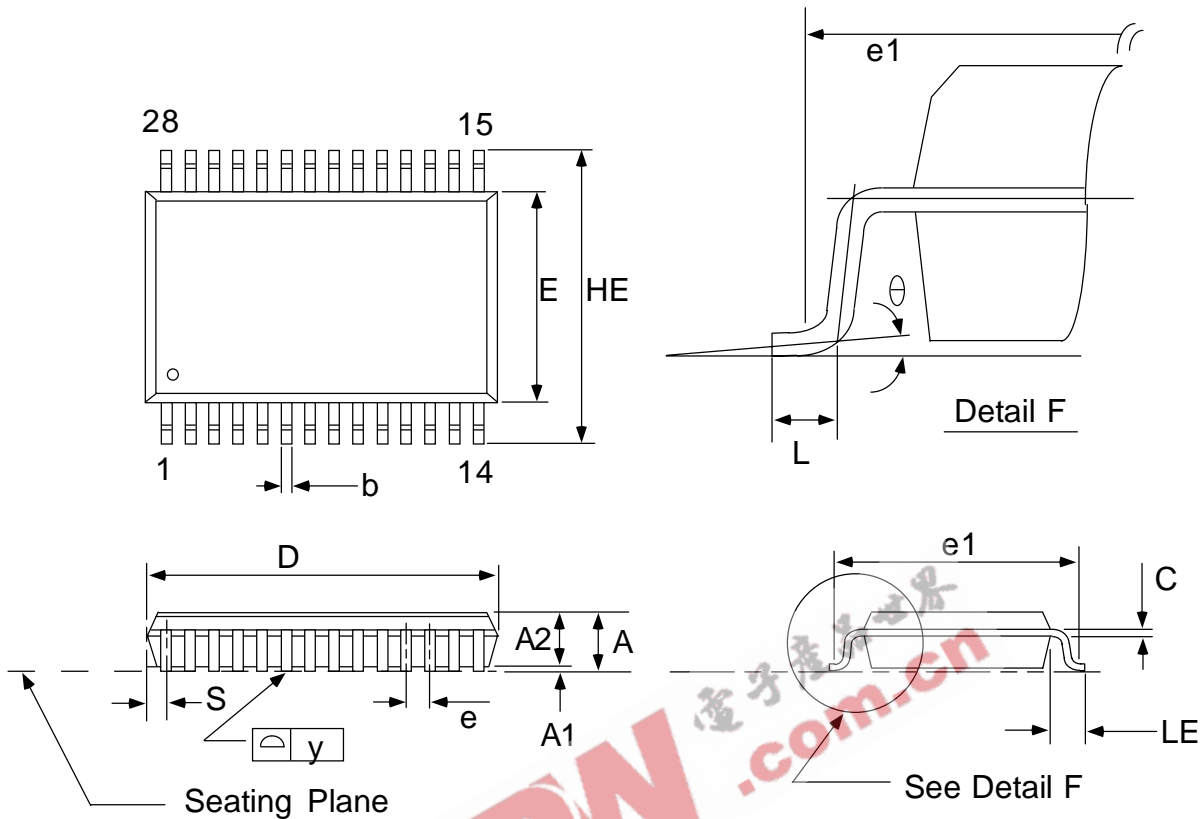

Symbol	Dimension in inches			Dimension in mm		
	min.	typ.	max.	min.	typ.	max.
A	-	-	0.098	-	-	2.5
A1	0.01	-	-	0.25	-	-
A2	0.083	0.085	0.087	2.13	2.15	2.17
b	0.014	0.016	0.018	0.39	0.4	0.41
C	0.004	0.006	0.008	0.1	0.15	0.2
D	-	0.713	0.733	-	18.1	18.6
E	0.322	0.331	0.338	8.2	8.4	8.6
e	0.044	0.050	0.056	1.12	1.27	1.42
HE	0.453	0.465	0.476	11.5	11.8	12.1
L	0.026	0.033	0.041	0.65	0.85	1.05
LE	0.047	0.059	0.071	1.2	1.5	1.8
S	-	39	-	-	1.0	-
y	-	-	0.005	-	-	0.12
θ	0°	-	10°	0°	-	10°

Notes :

1. Dimensions D max. & S include mold flash or tie bar burrs.
2. Dimension b does not include dambar protrusion / intrusion.
3. Dimensions D & E include mold mismatch and determined at the mold parting line.
4. controlling dimension : inches
5. general appearance spec should be based on final visual inspection spec.

PACKAGE DIMENSIONS

28-LEAD TSOP-I FORWARD AND REVERSE (8X13.4mm)

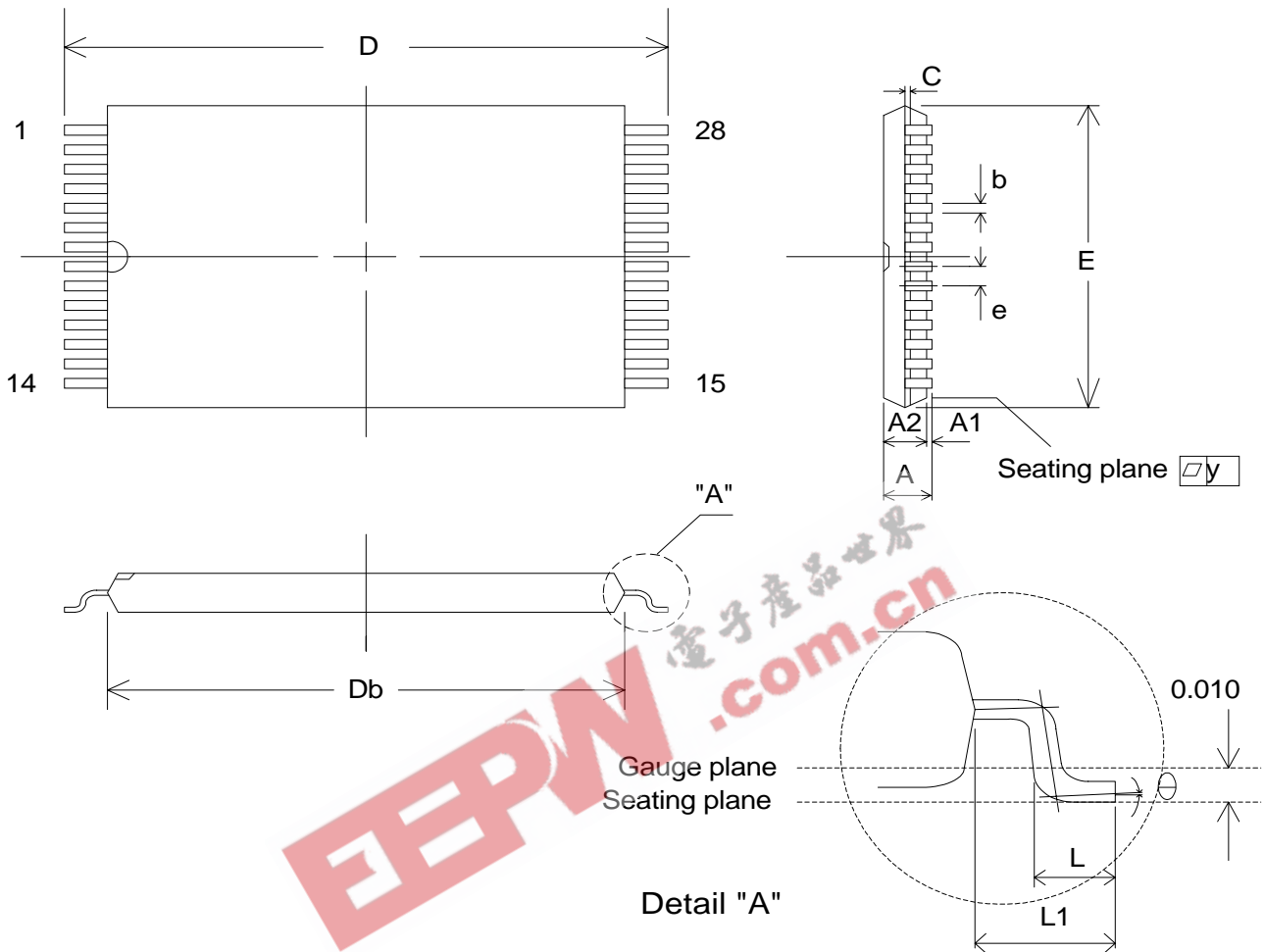

SYMBOL	DIMENSIONS IN INCHES	DIMENSIONS IN MM
A	0.047(max.)	1.20(max.)
A1	0.004±0.002	0.10±0.05
A2	0.039±0.002	1.00±0.05
b	0.008(typ.)	0.20(typ.)
c	0.006(typ.)	0.15(typ.)
Db	0.465±0.004	11.80±0.10
E	0.315±0.004	8.00±0.10
e	0.022(typ.)	0.55(typ.)
D	0.528±0.008	13.40±0.20
L	0.020±0.004	0.50±0.10
L1	0.0315±0.004	0.80±0.10
y	0.004(max.)	0.10(max.)
θ	0°~5°	0°~5°