

# Preliminary W49V002A



## 256K x 8 CMOS FLASH MEMORY WITH LPC INTERFACE

### GENERAL DESCRIPTION

The W49V002A is a 2megabit, 3.3-volt only CMOS flash memory organized as 256K × 8 bits. The device can be programmed and erased in-system with a standard 3.3V power supply. A 12-volt VPP is not required. The unique cell architecture of the W49V002A results in fast program/erase operations with extremely low current consumption. This device can operate at two modes, Programmer bus interface mode and LPC bus interface mode. As in the Programmer interface mode, it acts like the traditional flash but with a multiplexed address inputs. But in the LPC interface mode, this device complies with the Intel LPC specification 1.0. The device can also be programmed and erased using standard EPROM programmers.

### FEATURES

- Single 3.3-volt operations:
  - 3.3-volt Read
  - 3.3-volt Erase
  - 3.3-volt Program
- Fast Program operation:
  - Byte-by-Byte programming: 50 μS (typ.)
- Fast Erase operation: 150 mS (typ.)
- Endurance: 10K cycles (typ.)
- Twenty-year data retention
- Hardware data protection
  - #TBL & #WP serve as hardware protection
- One 16K bytes Boot Block with lockout protection
- Two 8K bytes Parameter Blocks
- Four Main Memory Blocks (with 32K bytes, 64K bytes, 64K bytes each)
- Low power consumption
  - Active current: 25 mA (typ.)
  - Standby current: 20 μA (typ.)
- Automatic program and erase timing with internal VPP generation
- End of program or erase detection
  - Toggle bit
  - Data polling
- Latched address and data
- TTL compatible I/O
- Available packages: 32L PLCC and 32L STSOP

# Preliminary W49V002A



## PIN CONFIGURATIONS

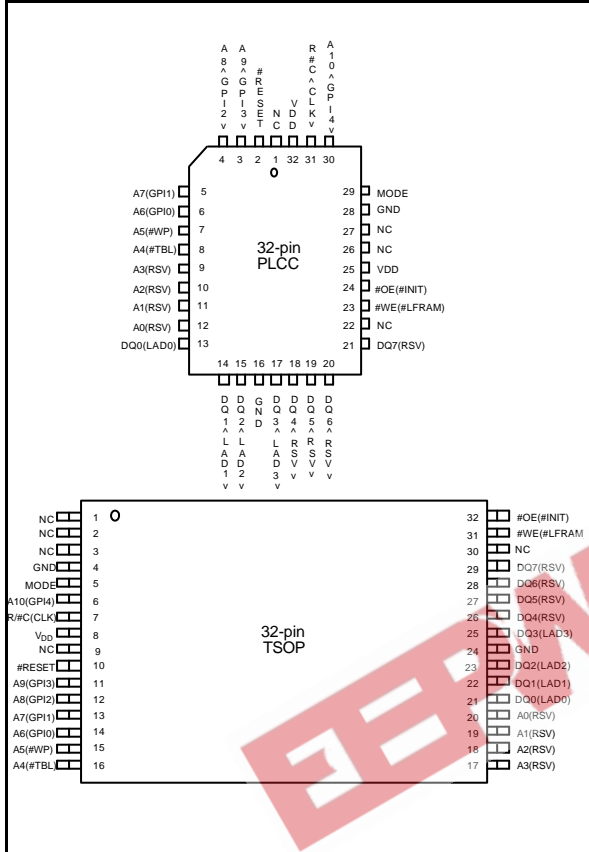

## PIN DESCRIPTION

SYMB	INTERFACE		PIN NAME
	PGM	LPC	
MODE	*	*	Interface Mode Selector
#RESET	*	*	Reset
#INIT		*	Initialize
#TBL		*	Top Boot Block Lock
#WP		*	Write Protect
CLK		*	CLK Input
GPI[4:0]		*	General Purpose Inputs
LAD[3:0]		*	Address/Data Inputs
#LFRAM		*	LPC Cycle Initial
R/#C	*		Row/Column Select
A[10:0]	*		Address Inputs
DQ[7:0]	*		Data Inputs/Outputs
#OE	*		Output Enable
#WE	*		Write Enable
VDD	*	*	Power Supply
GND	*	*	Ground
RSV	*	*	Reserve Pins
NC	*	*	No Connection

## BLOCK DIAGRAM

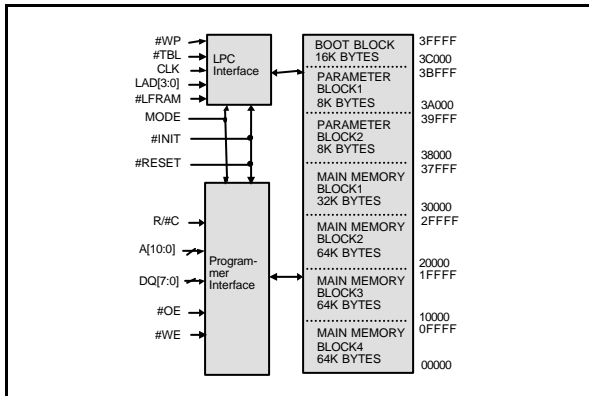



## FUNCTIONAL DESCRIPTION

### Interface Mode Selection And Description

This device can be operated in two interface modes, one is Programmer interface mode, the other is LPC interface mode. The MODE pin of the device provides the control between these two interface modes. These interface modes need to be configured before power up or return from #RESET. When MODE pin is set to high state, the device is in the Programmer mode; while the MODE pin is set to low state (or left no connection), it is in the LPC mode. In Programmer mode, this device just behaves like traditional flash parts with 8 data lines. But the row and column address inputs are multiplexed, which go through the address inputs A[10:0]. For LPC mode, It complies with the LPC Interface Specification Revision 1.0. Through LAD[3:0] to communicate with the system chipset .

### Read(Write) Mode

In Programmer interface mode, the read(write) operation of the W49V002A is controlled by #OE (#WE). The #OE (#WE) is held low for the host to obtain(write) data from(to) the outputs(inputs). #OE is the output control and is used to gate data from the output pins. The data bus is in high impedance state when #OE is high. As in the LPC interface mode, the read or write is determined by the "bit 1 of CYCLE TYPEDIR".

### Reset Operation

The #RESET input pin can be used in some application. When #RESET pin is at high state, the device is in normal operation mode. When #RESET pin is at low state, it will halt the device and all outputs will be at high impedance state. As the high state re-asserted to the #RESET pin, the device will return to read or standby mode, it depends on the control signals.

### Chip Erase Operation

The chip-erase mode can be initiated by a six-byte command sequence. After the command loading cycle, the device enters the internal chip erase mode, which is automatically timed and will be completed within fast 100 mS (typical). The host system is not required to provide any control or timing during this operation. If the boot block programming lockout is activated, only the data in the other memory blocks will be erased to FF(hex) while the data in the boot block will not be erased (remains as the same state before the chip erase operation). The entire memory array will be erased to FF(hex) by the chip erase operation if the boot block programming lockout feature is not activated. The device will automatically return to normal read mode after the erase operation completed. Data polling and/or Toggle Bits can be used to detect end of erase cycle.

### Sector Erase Operation

The seven sectors, one boot block and two parameter blocks and four main blocks, can be erased individually by initiating a six-byte command sequence. Sector address is latched on the falling #WE edge of the sixth cycle, while the 30(hex) data input command is latched at the rising edge of #WE. After the command loading cycle, the device enters the internal sector erase mode, which is automatically timed and will be completed within fast 150 mS (typical). The host system is not required to provide any control or timing during this operation. The device will automatically return to normal read mode after the erase operation completed. Data polling and/or Toggle Bits can be used to detect end of erase cycle.

### Program Operation

The W49V002A is programmed on a byte-by-byte basis. Program operation can only change logical data



"1" to logical data "0." The erase operation, which changed entire data in main memory and/or boot block from "0" to "1", is needed before programming.

The program operation is initiated by a 4-byte command cycle (see Command Codes for Byte Programming). The device will internally enter the program operation immediately after the byte-program command is entered. The internal program timer will automatically time-out (100  $\mu$ S max. - TBP) once it is completed and then return to normal read mode. Data polling and/or Toggle Bits can be used to detect end of program cycle.

## Boot Block Operation and Hardware Protection at Initial- #TBL & #WP

There are two alternatives to set the boot block. One is software command sequences method; the other is hardware method. 16K-byte in the top location of this device can be locked as boot block, which can be used to store boot codes. It is located in the last 16K bytes of the memory with the address range from 3C000(hex) to 3FFFF(hex).

Please see Command Codes for Boot Block Lockout Enable for the specific code. Once this feature is set, the data for the designated block cannot be erased or programmed (programming lockout), other memory locations can be changed by the regular programming method.

Besides the software method, there is a hardware method to protect the top boot block and other sectors. Before program/erase to this device, set the #TBL pin to low state and then the top boot block will not be programmed/erased. When enabling hardware top boot block, #TBL being low state, it will override the software method setting. That is, if #TBL is at low state, then top boot block cannot be programmed/erased no matter how the software boot block lock setting.

Another pin, #WP, will protect the whole chip if this pin is set to low state before program/erase. The enable of this pin will override the #TBL setting. That is, the top boot block cannot be programmed/erased if this pin is set to low no matter how the #TBL or software boot block lock setting.

## Hardware Data Protection

The integrity of the data stored in the W49V002A is also hardware protected in the following ways:

- (1) Noise/Glitch Protection: A #WE pulse of less than 15 nS in duration will not initiate a write cycle.
- (2) VDD Power Up/Down Detection: The programming operation is inhibited when VDD is less than 1.5V typical.
- (3) Write Inhibit Mode: Forcing #OE low or #WE high will inhibit the write operation. This prevents inadvertent writes during power-up or power-down periods.
- (4) VDD power-on delay: When VDD has reached its sense level, the device will automatically time-out 5 mS before any write (erase/program) operation.

## Data Polling (DQ7)- Write Status Detection

The W49V002A includes a data polling feature to indicate the end of a program or erase cycle. When the W49V002A is in the internal program or erase cycle, any attempts to read DQ7 of the last byte loaded will receive the complement of the true data. Once the program or erase cycle is completed, DQ7 will show the true data. Note that DQ7 will show logical "0" during the erase cycle, and when erase cycle has been completed it becomes logical "1" or true data.

## Toggle Bit (DQ6)- Write Status Detection

In addition to data polling, the W49V002A provides another method for determining the end of a program cycle. During the internal program or erase cycle, any consecutive attempts to read DQ6 will produce alternating 0's and 1's. When the program or erase cycle is completed, this toggling between 0's and 1's will stop. The device is then ready for the next operation.



## Memory Address Map

There are 8M bytes space reserved for BIOS Addressing. The ROM will respond to 256K byte pages whenever the memory address rang is within the top 4M bytes and bottom 128K bytes.

The 32bit address space is as below:

Block	Address Range
4M Byte BIOS ROM	FFFF,FFFFh:FFC0,0000h
128K Byte BIOS ROM	000F,FFFFh:000E,0000h
Registers	FFBC,0100h

## General Purpose Inputs Register

This register reads the GPI[4:0] pins on the W49V002A. This is a pass-through register which can read via memory address FFBC0100(hex). Since it is pass-through register, there is no default value.

Bit	Function
7-5	Reserved
4	Read GPI4 pin status
3	Read GPI3 pin status
2	Read GPI2 pin status
1	Read GPI1 pin status
0	Read GPI0 pin status

## Product Identification

The product ID operation outputs the manufacturer code and device code. Programming equipment automatically matches the device with its proper erase and programming algorithms.

The manufacturer and device codes can be accessed by software operation. In the software access mode, a six-byte (or JEDEC 3-byte) command sequence can be used to access the product ID. A read from address 0000(hex) outputs the manufacturer code, DA(hex). A read from address 0001(hex) outputs the device code, B0(hex)." The product ID operation can be terminated by a three-byte command sequence or an alternate one-byte command sequence (see Command Definition table).



## TABLE OF OPERATING MODES

### Operating Mode Selection - Programmer Mode

(V<sub>HH</sub> = 12V ± 5%)

MODE	PINS				
	#OE	#WE	#RESET	ADDRESS	DQ.
Read	VIL	VIH	VIH	A <sub>IN</sub>	D <sub>out</sub>
Write	VIH	VIL	VIH	A <sub>IN</sub>	D <sub>in</sub>
Standby	X	X	VIL	X	High Z
Write Inhibit	VIL	X	VIH	X	High Z/DOUT
	X	VIH	VIH	X	High Z/DOUT
Output Disable	VIH	X	VIH	X	High Z

### Operating Mode Selection - LPC Mode

Operation modes in LPC interface mode are determined by "cycle type" when it is selected. When it is not selected, its outputs (LAD[3:0]) will be disable. Please reference to the "Standard LPC Memory Cycle Definition".

## TABLE OF COMMAND DEFINITION

COMMAND DESCRIPTION	NO. OF Cycles	1ST CYCLE	2ND CYCLE	3RD CYCLE	4TH CYCLE	5TH CYCLE	6TH CYCLE
		Addr. Data	Addr. Data	Addr. Data	Addr. Data	Addr. Data	Addr. Data
Read	1	A <sub>IN</sub> D <sub>OUT</sub>					
Chip Erase	6	5555 AA	2AAA 55	5555 80	5555 AA	2AAA 55	5555 10
Sector Erase	6	5555 AA	2AAA 55	5555 80	5555 AA	2AAA 55	SA 30
Byte Program	4	5555 AA	2AAA 55	5555 A0	A <sub>IN</sub> D <sub>IN</sub>		
Boot Block Lockout	6	5555 AA	2AAA 55	5555 80	5555 AA	2AAA 55	5555 40
Product ID Entry	3	5555 AA	2AAA 55	5555 90			
Product ID Exit <sup>(1)</sup>	3	5555 AA	2AAA 55	5555 F0			
Product ID Exit <sup>(1)</sup>	1	XXXX F0					

Note: 1. The cycle means the write command cycle not the LPC clock cycle.

- The Column Address / Row Address are mapped to the Low / High order Internal Address. i.e. Column Address A[10:0] are mapped to the internal A[10:0], Row Address A[6:0] are mapped to the internal A[17:11]
- Address Format: A14–A0 (Hex); Data Format: DQ7–DQ0 (Hex)
- Either one of the two Product ID Exit commands can be used.
- SA : Sector Address
  - SA = 3C000h to 3FFFFh for Boot Block
  - SA = 3A000h to 3BFFFh for Parameter Block1
  - SA = 38000h to 39FFFh for Parameter Block2
  - SA = 30000h to 37FFFh for Main Memory Block1
  - SA = 2XXXXh for Main Memory Block2
  - SA = 1XXXXh for Main Memory Block3
  - SA = 0XXXXh for Main Memory Block4



## STANDARD LPC MEMORY CYCLE DEFINITION

FIELD	NO. OF CLOCKS	DESCRIPTION
Start	1	"0000b" appears on LPC bus to indicate the initial
Cycle Type & Dir	1	"010Xb" indicates memory read cycle; while "011xb" indicates memory write cycle. "X" mean don't have to care.
TAR	2	Turned Around Time
Addr.	8	Address Phase for Memory Cycle. LPC supports the 32 bits address protocol. The addresses transfer most significant nibble first and least significant nibble last. (i.e. Address[31:28] on LAD[3:0] first , and Address[3:0] on LAD[3:0] last.)
Sync.	N	Synchronous to add wait state. "0000b" means Ready, "0101b" means Short Wait, "0110b" means Long Wait, "1001b" for DMA only, "1010b" means error, and other values are reserved.
Data	2	Data Phase for Memory Cycle. The data transfer least significant nibble first and most significant nibble last. (i.e. DQ[3:0] on LAD[3:0] first , then DQ[7:4] on LAD[3:0] last.)

Note: 1. For detail related LPC specification, please refer to Intel LPC spec. 1.0 or later.

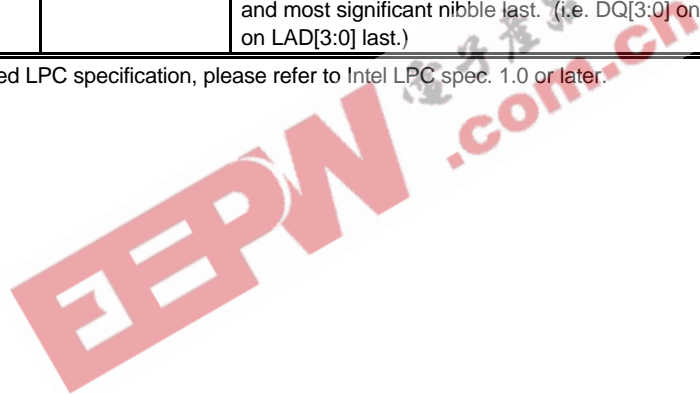



## Command Codes for Byte Program

BYTE SEQUENCE	ADDRESS	DATA
0 Write	5555H	AAH
1 Write	2AAAH	55H
2 Write	5555H	A0H
3 Write	Programmed-Address	Programmed-Data

## Byte Program Flow Chart

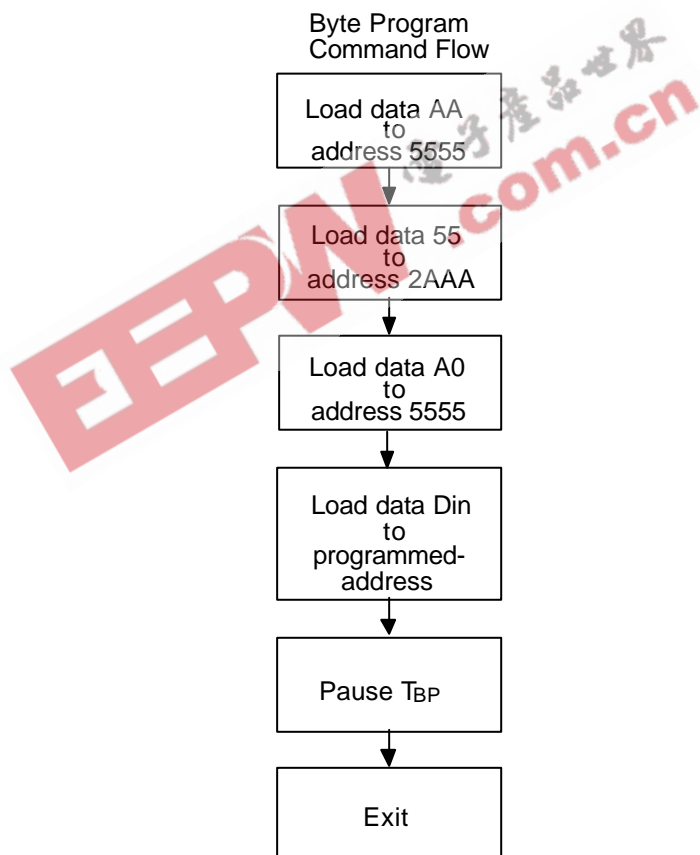

Notes for software program code:

Data Format: DQ7–DQ0 (Hex); XX = Don't Care

Address Format: A14–A0 (Hex)





## Command Codes for Chip Erase

BYTE SEQUENCE	ADDRESS	DATA
1 Write	5555H	AAH
2 Write	2AAAH	55H
3 Write	5555H	80H
4 Write	5555H	AAH
5 Write	2AAAH	55H
6 Write	5555H	10H

## Chip Erase Acquisition Flow

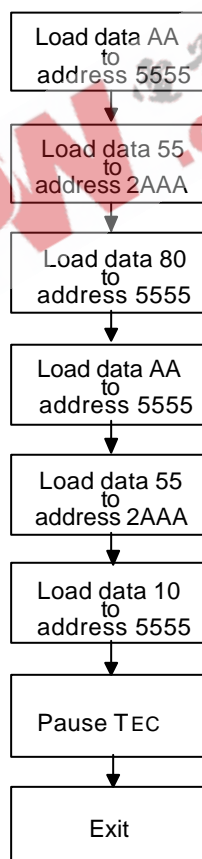

Notes for chip erase:

Data Format: DQ7–DQ0 (Hex)

Address Format: A14–A0 (Hex)



## Command Codes for Sector Erase

BYTE SEQUENCE	ADDRESS	DATA
1 Write	5555H	AAH
2 Write	2AAAH	55H
3 Write	5555H	80H
4 Write	5555H	AAH
5 Write	2AAAH	55H
6 Write	SA*	30H

## Sector Erase Acquisition Flow

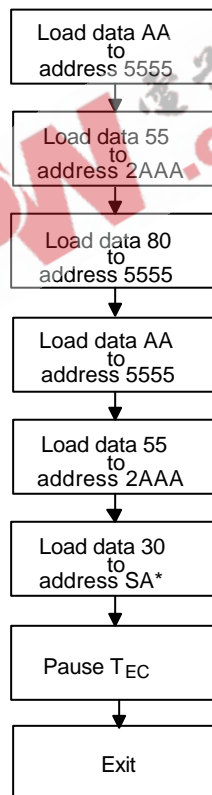

Notes for chip erase:

Data Format: DQ7–DQ0 (Hex)

Address Format: A14–A0 (Hex)

SA : Sector Address

SA = 3C000h to 3FFFFh for Boot Block

SA = 3A000h to 3BFFFh for Parameter Block1    SA = 2XXXXh for Main Memory Block2

SA = 38000h to 39FFFh for Parameter Block2    SA = 1XXXXh for Main Memory Block3

SA = 30000h to 37FFFh for Main Memory Block1    SA = 0XXXXh for Main Memory Block4

# Preliminary W49V002A



## Command Codes for Product Identification and Boot Block Lockout Detection

BYTE SEQUENCE	SOFTWARE PRODUCT IDENTIFICATION / BOOT BLOCK LOCKOUT DETECTION ENTRY		SOFTWARE PRODUCT IDENTIFICATION / BOOT BLOCK LOCKOUT DETECTION EXIT (6)	
	ADDRESS	DATA	ADDRESS	DATA
1 Write	5555	AA	5555H	AAH
2 Write	2AAA	55	2AAAH	55H
3 Write	5555	90	5555H	F0H
	Pause 10 $\mu$ S		Pause 10 $\mu$ S	

## Software Product Identification and Boot Block Lockout Detection Acquisition Flow

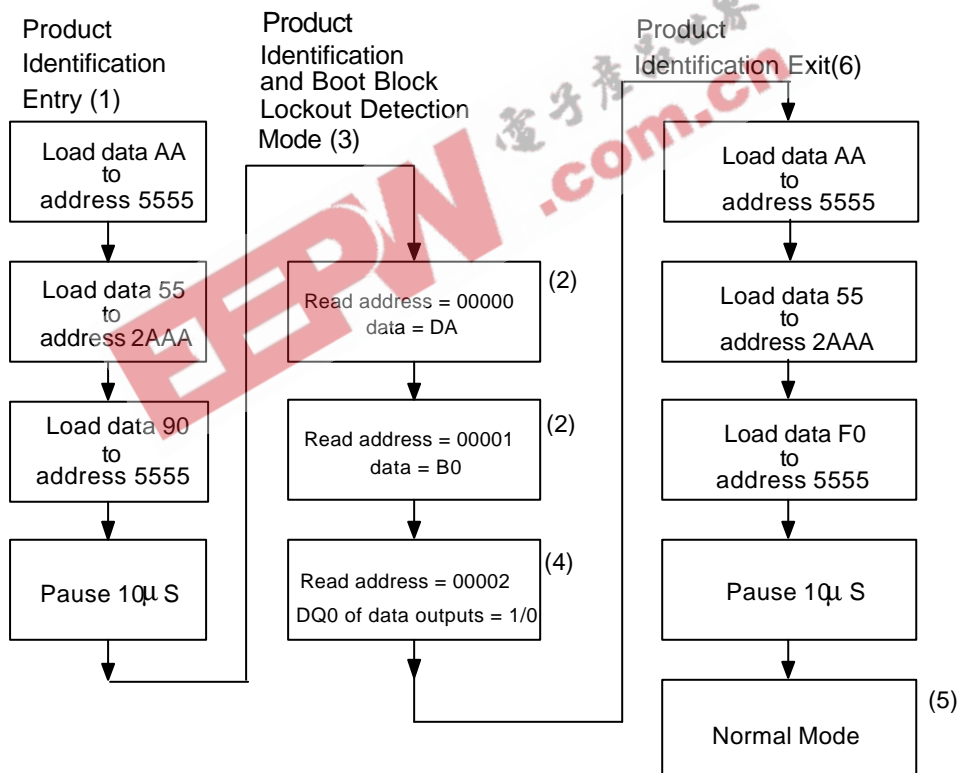

Notes for software product identification/boot block lockout detection:

- (1) Data Format: DQ7–DQ0 (Hex); Address Format: A14–A0 (Hex)
- (2) A1–A17 = V<sub>L</sub>; manufacture code is read for A0 = V<sub>L</sub>; device code is read for A0 = V<sub>H</sub>.
- (3) The device does not remain in identification and boot block lockout detection mode if power down.
- (4) If the DQ0 of output data is "1," the boot block programming lockout feature is activated; if the DQ0 of output data "0," the lockout feature is inactivated and the block can be programmed.
- (5) The device returns to standard operation mode.
- (6) Optional 1-write cycle (write F0 hex at XXXX address) can be used to exit the product identification/boot block lockout detection.



## Command Codes for Boot Block Lockout Enable

BYTE SEQUENCE	BOOT BLOCK LOCKOUT FEATURE SET	
	ADDRESS	DATA
1 Write	5555H	AAH
2 Write	2AAAH	55H
3 Write	5555H	80H
4 Write	5555H	AAH
5 Write	2AAAH	55H
6 Write	5555H	40H
Pause 1 Sec.		

## Boot Block Lockout Enable Acquisition Flow

### Boot Block Lockout Feature Set Flow

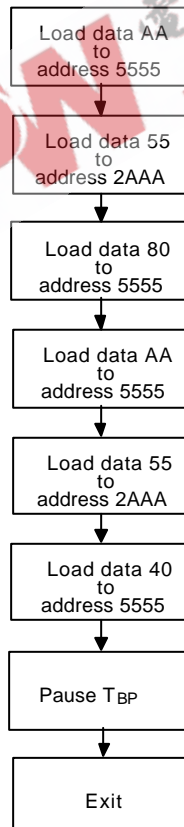

Notes for boot block lockout enable:

Data Format: DQ7–DQ0 (Hex)

Address Format: A14–A0 (Hex)

# Preliminary W49V002A



## DC CHARACTERISTICS

### Absolute Maximum Ratings

PARAMETER	RATING	UNIT
Power Supply Voltage to V <sub>SS</sub> Potential	-0.5 to +4.1	V
Operating Temperature	0 to +70	°C
Storage Temperature	-65 to +150	°C
D.C. Voltage on Any Pin to Ground Potential	-0.5 to V <sub>DD</sub> +0.5	V
Transient Voltage (<20 nS ) on Any Pin to Ground Potential	-1.0 to V <sub>DD</sub> +0.5	V

Note: Exposure to conditions beyond those listed under Absolute Maximum Ratings may adversely affect the life and reliability of the device.

### Programmer interface Mode DC Operating Characteristics

(V<sub>DD</sub> 3.3V ± 5%, V<sub>GND</sub>= 0V, T<sub>A</sub> = 0 to 70° C)

PARAMETER	SYM.	TEST CONDITIONS	LIMITS			UNIT
			MIN.	TYP.	MAX.	
Power Supply Current	I <sub>CC</sub>	In Read or Write mode, all DQs open Address inputs = 3.0V/0V, at f = 3 MHz	-	20	30	mA
Input Leakage Current	I <sub>LI</sub>	V <sub>IN</sub> = GND to V <sub>DD</sub>	-	-	10	μA
Output Leakage Current	I <sub>LO</sub>	V <sub>OUT</sub> = GND to V <sub>DD</sub>	-	-	10	μA
Input Low Voltage	V <sub>IL</sub>	-	-0.3	-	0.8	V
Input High Voltage	V <sub>IH</sub>	-	2.0	-	V <sub>DD</sub> +0.5	V
Output Low Voltage	V <sub>OL</sub>	I <sub>OL</sub> = 2.1 mA	-	-	0.45	V
Output High Voltage	V <sub>OH</sub>	I <sub>OH</sub> = -0.1mA	2.4	-	-	V

# Preliminary W49V002A



## LPC interface Mode DC Operating Characteristics

(V<sub>DD</sub> = 3.3V ± 5%, V<sub>GND</sub> = 0V, T<sub>A</sub> = 0 to 70° C)

PARAMETER	SYM.	TEST CONDITIONS	LIMITS			UNIT
			MIN.	TYP.	MAX.	
Power Supply Current	I <sub>CC</sub>	All I <sub>out</sub> = 0A, CLK = 33MHz, in LPC mode operation.	-	40	60	mA
CMOS Standby Current	I <sub>sb1</sub>	#LFRAM = 0.9 V <sub>DD</sub> , CLK = 33MHz, all inputs = 0.9 V <sub>DD</sub> / 0.1 V <sub>DD</sub>	-	20	100	uA
TTL Standby Current	I <sub>sb2</sub>	#LFRAM = 0.1 V <sub>DD</sub> , CLK = 33MHz, all inputs = 0.9 V <sub>DD</sub> / 0.1 V <sub>DD</sub>	-	3	10	mA
Input Low Voltage	V <sub>IL</sub>	-	-0.3	-	0.2 V <sub>DD</sub>	V
Input High Voltage	V <sub>IH</sub>	-	0.6 V <sub>DD</sub>	-	V <sub>DD</sub> + 0.5	V
Output Low Voltage	V <sub>OL</sub>	I <sub>OL</sub> = 1.5 mA	-	-	0.1 V <sub>DD</sub>	V
Output High Voltage	V <sub>OH</sub>	I <sub>OH</sub> = -0.5 mA	0.9 V <sub>DD</sub>	-	-	V

## Power-up Timing

PARAMETER	SYMBOL	TYPICAL	UNIT
Power-up to Read Operation	TPU. READ	100	μS
Power-up to Write Operation	TPU. WRITE	5	mS

## CAPACITANCE

(V<sub>DD</sub> = 3.3V, T<sub>A</sub> = 25° C, f = 1 MHz)

PARAMETER	SYMBOL	CONDITIONS	MAX.	UNIT
I/O Pin Capacitance	C <sub>I/O</sub>	V <sub>I/O</sub> = 0V	12	pf
Input Capacitance	C <sub>IN</sub>	V <sub>IN</sub> = 0V	6	pf

# Preliminary W49V002A



## PROGRAMMER INTERFACE MODE AC CHARACTERISTICS

### AC Test Conditions

PARAMETER	CONDITIONS
Input Pulse Levels	0V to 0.9V <sub>DD</sub>
Input Rise/Fall Time	< 5 nS
Input/Output Timing Level	1.5V/1.5V
Output Load	1 TTL Gate and C <sub>L</sub> = 30 pF

### AC Test Load and Waveform

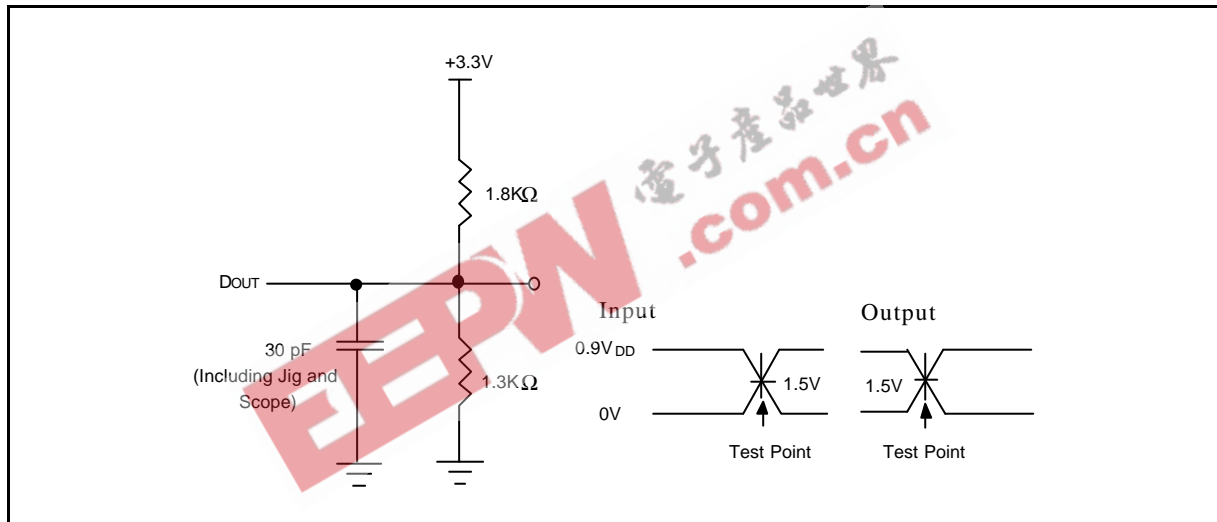

# Preliminary W49V002A



Programmer Interface Mode AC Characteristics, continued

## AC Characteristics

### Read Cycle Timing Parameters

(V<sub>DD</sub> = 3.3V ± 5%, V<sub>GND</sub> = 0V, T<sub>A</sub> = 0 to 70° C)

PARAMETER	SYM.	W49V002A		UNIT
		MIN.	MAX.	
Read Cycle Time	TRC	300	-	nS
Row / Column Address Set Up Time	TAS	50	-	nS
Row / Column Address Hold Time	TAH	50	-	nS
Address Access Time	TAA	-	200	nS
Output Enable Access Time	TOE	-	100	nS
#OE Low to Active Output	TOLZ	0	-	nS
#OE High to High-Z Output	TOHZ	-	50	nS
Output Hold from Address Change	TOH	0	-	nS

### Write Cycle Timing Parameters

PARAMETER	SYMBOL	MIN.	TYP.	MAX.	UNIT
Reset Time	TRST	1	-	-	μS
Address Setup Time	TAS	50	-	-	nS
Address Hold Time	TAH	50	-	-	nS
R/#C to Write Enable High Time	TCWH	50	-	-	nS
#WE Pulse Width	TWP	100	-	-	nS
#WE High Width	TWPH	100	-	-	nS
Data Setup Time	TDS	50	-	-	nS
Data Hold Time	TDH	50	-	-	nS
#OE Hold Time	TOEH	0	-	-	nS
Byte programming Time	TBP	-	50	100	μS
Erase Cycle Time	TEC	-	0.15	0.2	S

Note: All AC timing signals observe the following guidelines for determining setup and hold times:

- (a) High level signal's reference level is input high and (b) low level signal's reference level is input low.  
Ref. to the AC testing condition.

### Data Polling and Toggle Bit Timing Parameters

PARAMETER	SYM	W49V002A		UNIT
		MIN.	MAX.	
#OE to Data Polling Output Delay	TOEP	-	40	nS
#OE to Toggle Bit Output Delay	TOET	-	40	nS



# Preliminary W49V002A



## TIMING WAVEFORMS FOR PROGRAMMER INTERFACE MODE

### Read Cycle Timing Diagram

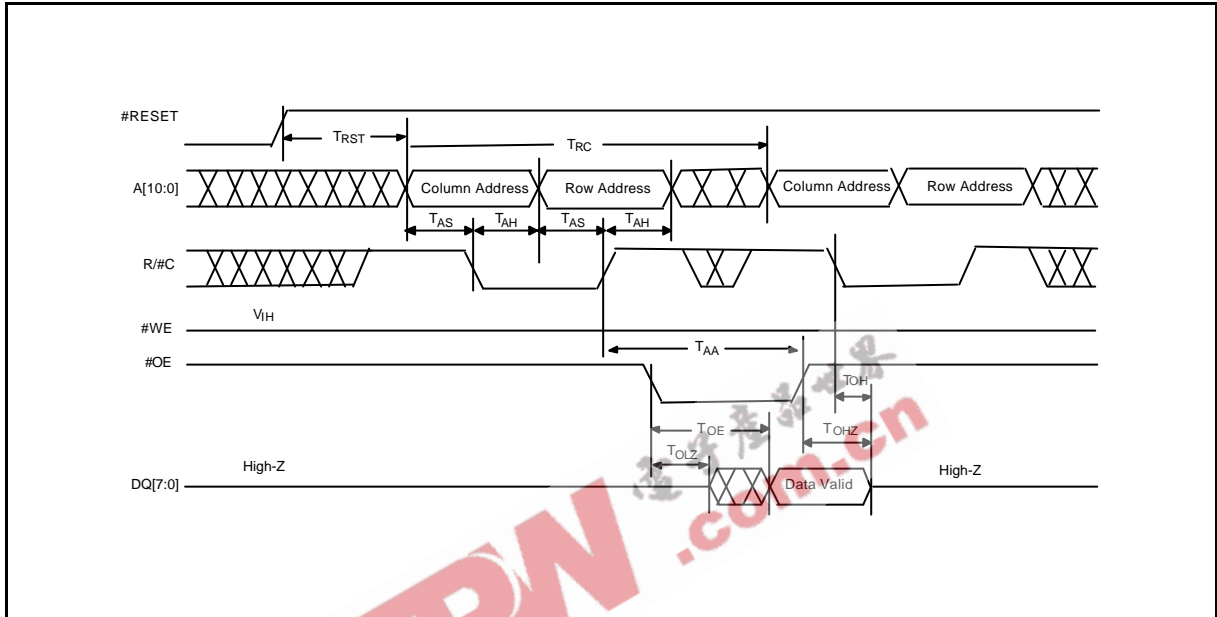

### Write Cycle Timing Diagram

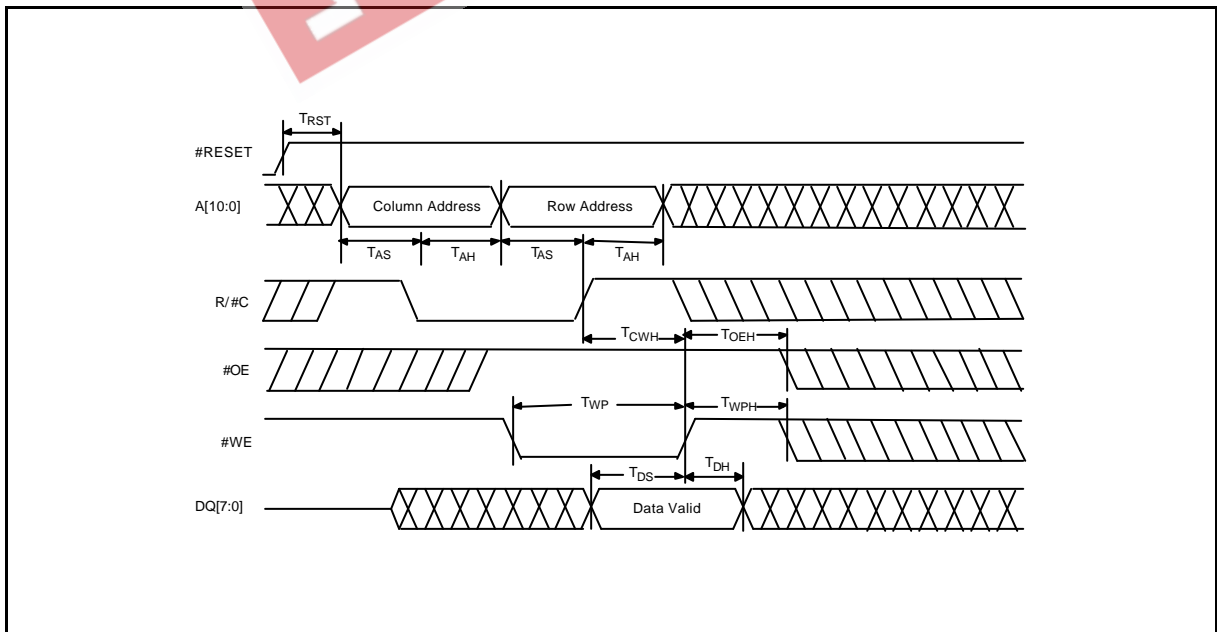



Timing Waveforms for Programmer Interface Mode, continued

## Program Cycle Timing Diagram

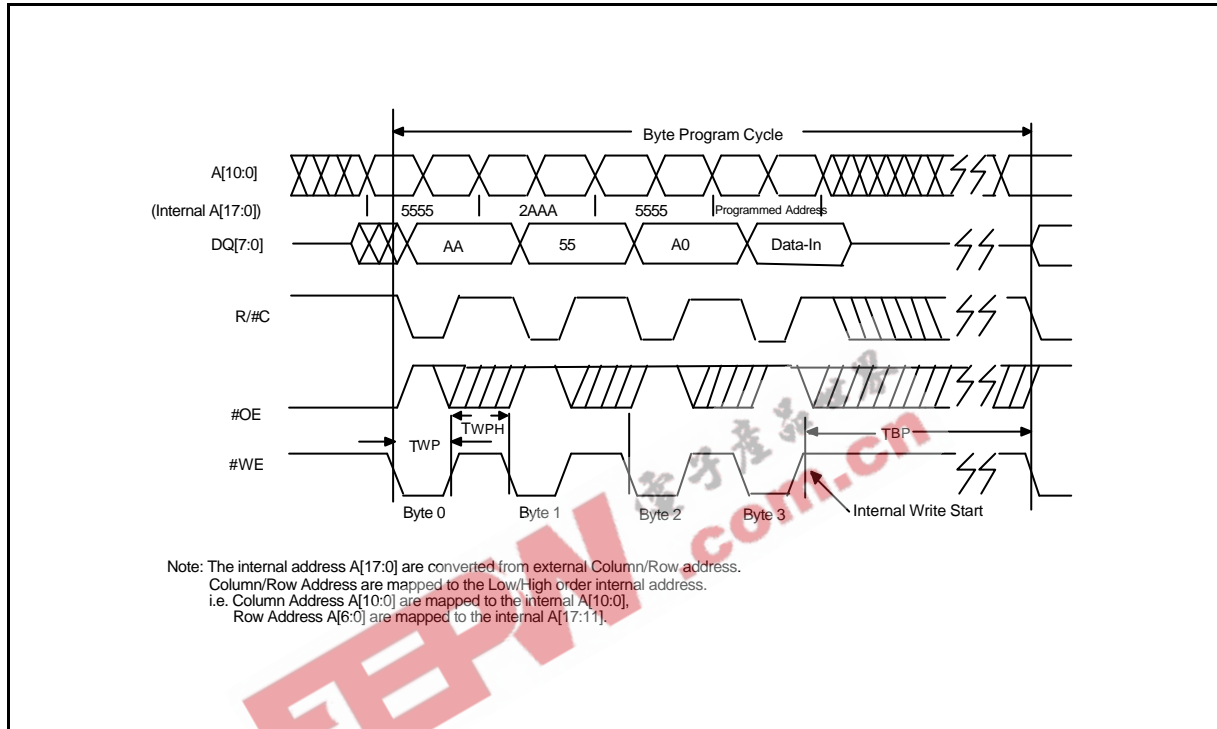

## #DATA Polling Timing Diagram

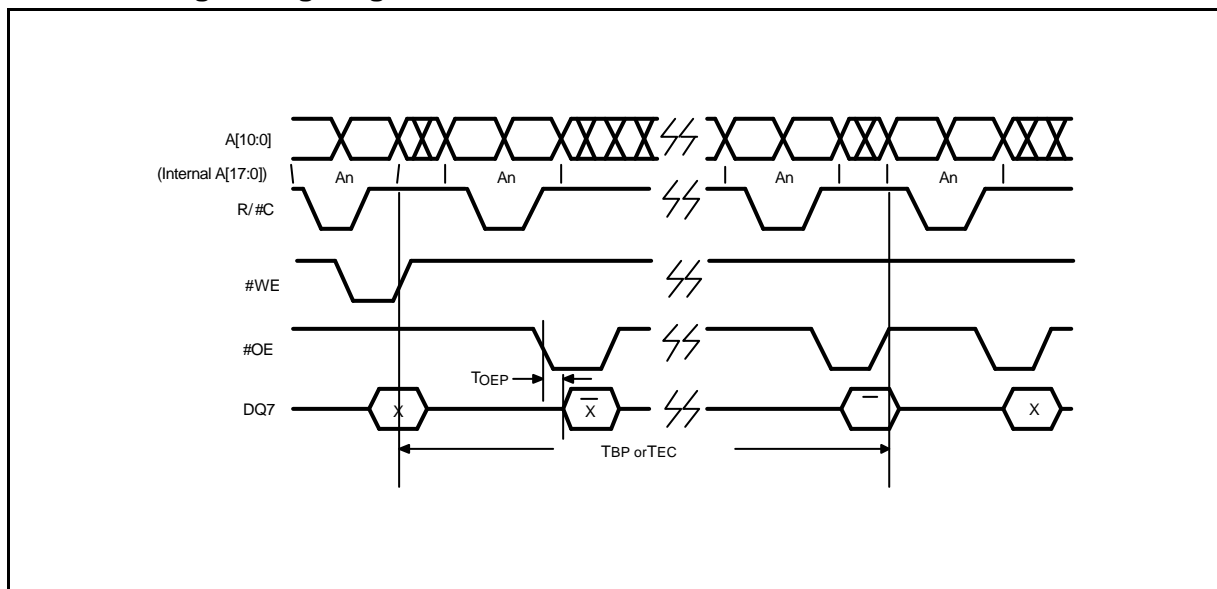

# Preliminary W49V002A



Timing Waveforms for Programmer Interface Mode, continued

## Toggle Bit Timing Diagram

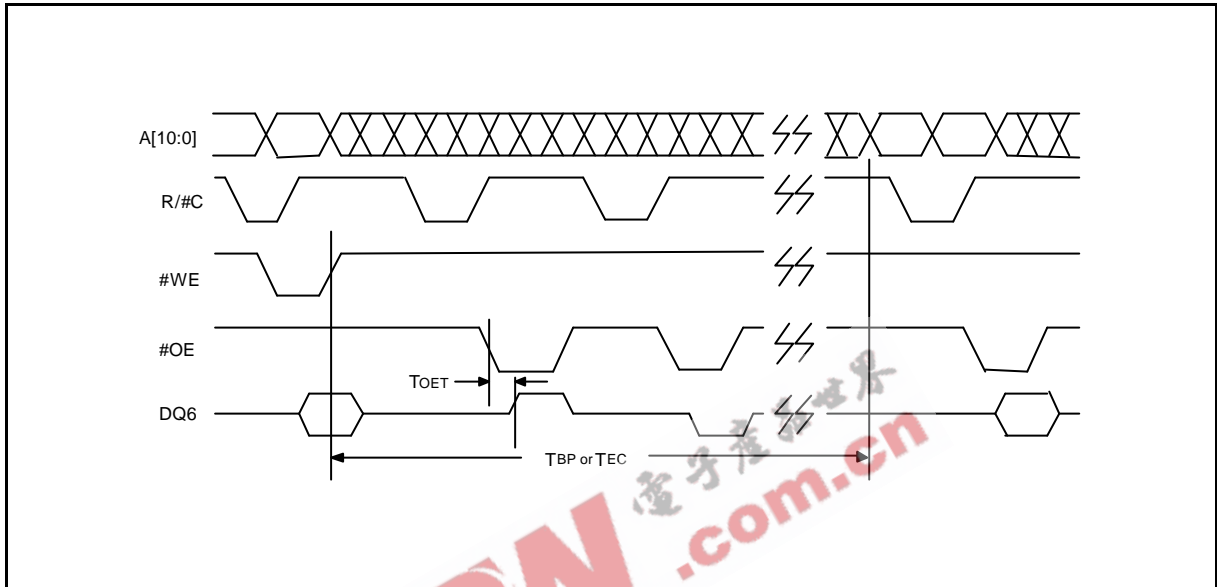

## Boot Block Lockout Enable Timing Diagram

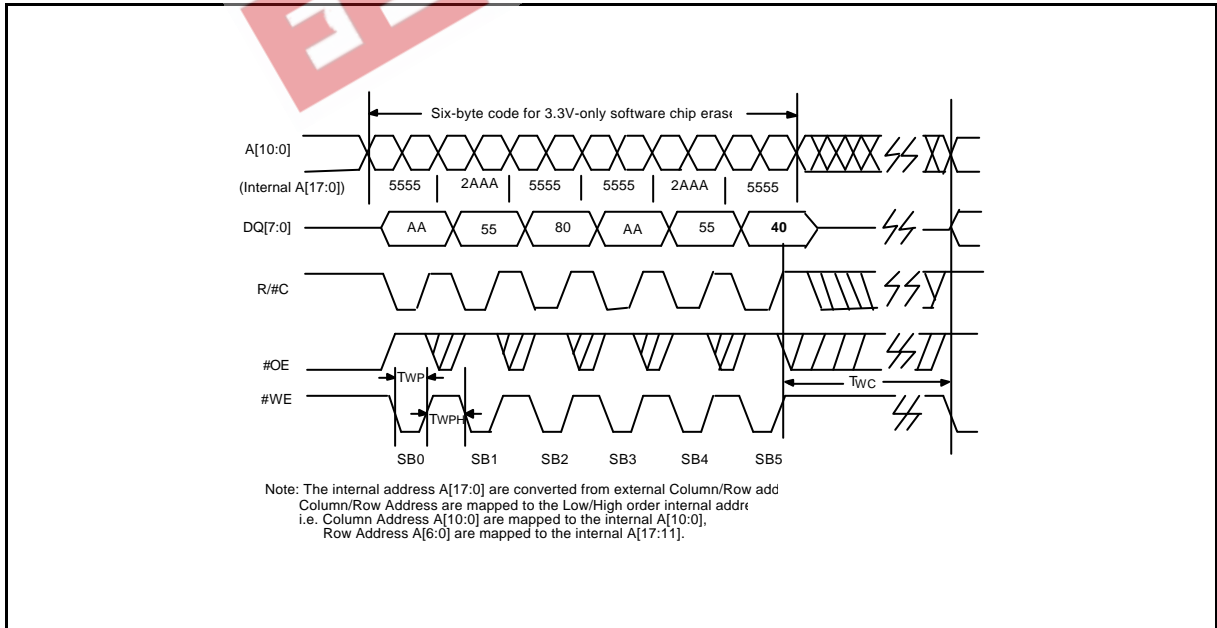



Timing Waveforms for Programmer Interface Mode, continued

## Chip Erase Timing Diagram

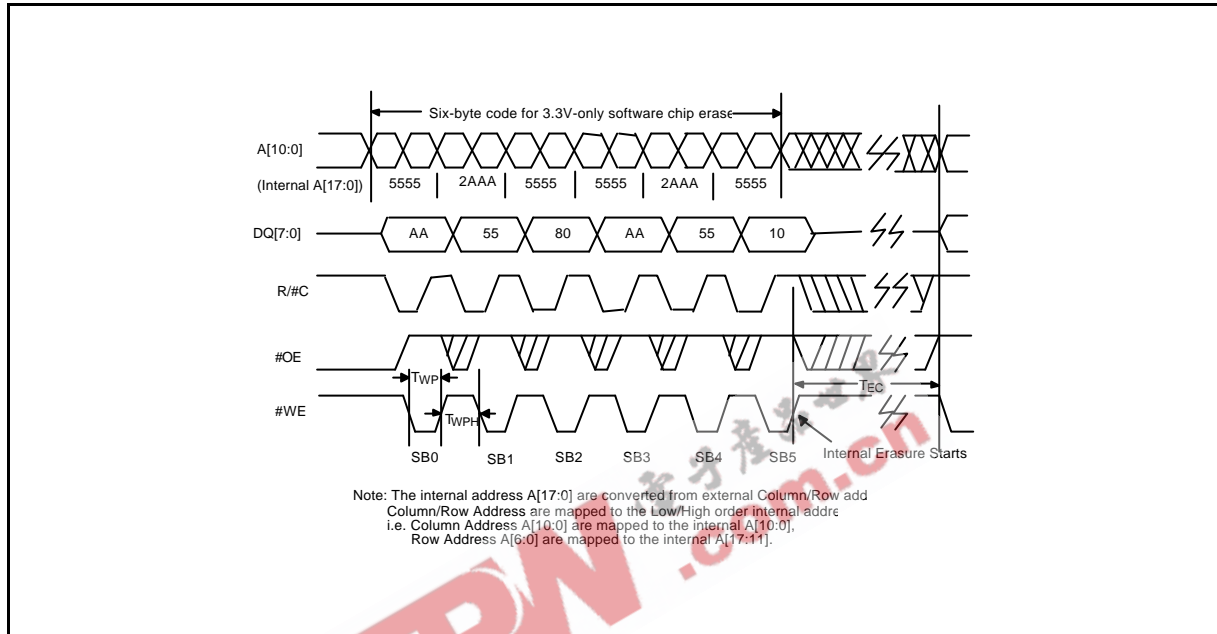

## Sector Erase Timing Diagram

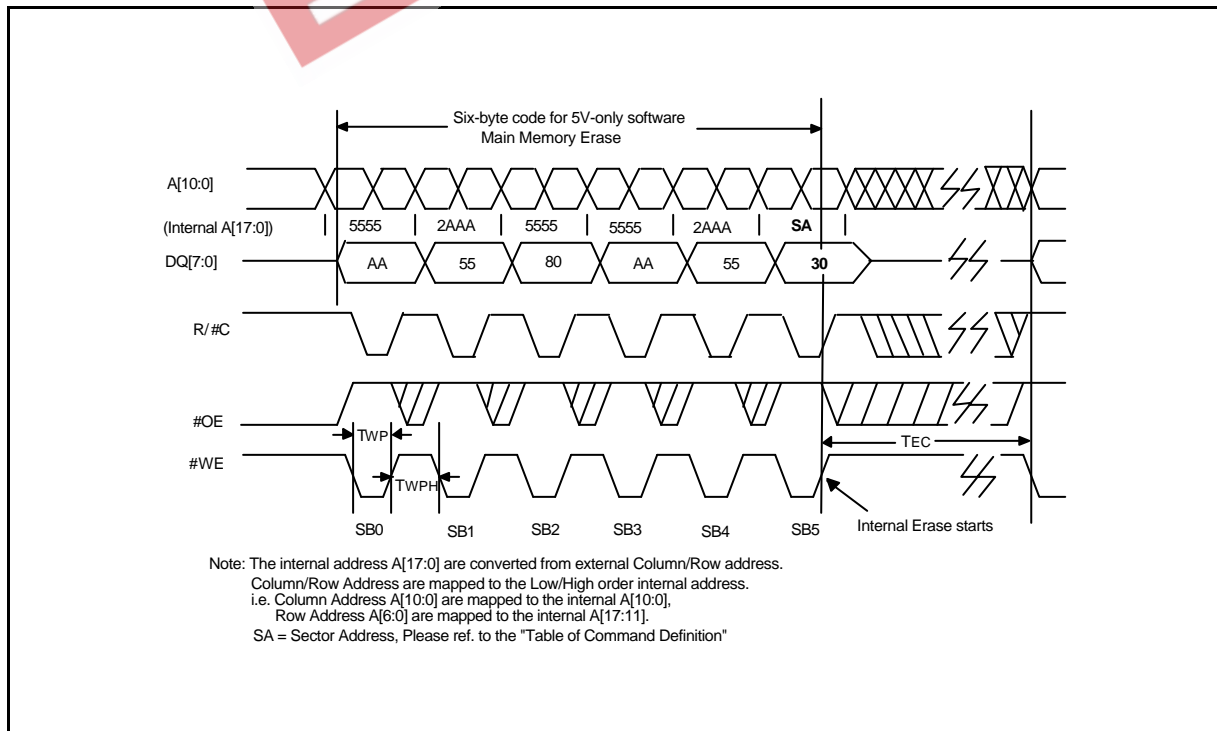

# Preliminary W49V002A



## LPC INTERFACE MODE AC CHARACTERISTICS

### AC Test Conditions

PARAMETER	CONDITIONS
Input Pulse Levels	0.6 V <sub>DD</sub> to 0.2 V <sub>DD</sub>
Input Rise/Fall Slew Rate	1 V/nS
Input/Output Timing Level	0.4V <sub>DD</sub> / 0.4V <sub>DD</sub>
Output Load	1 TTL Gate and C <sub>L</sub> = 10 pF

### AC Test Load and Waveform

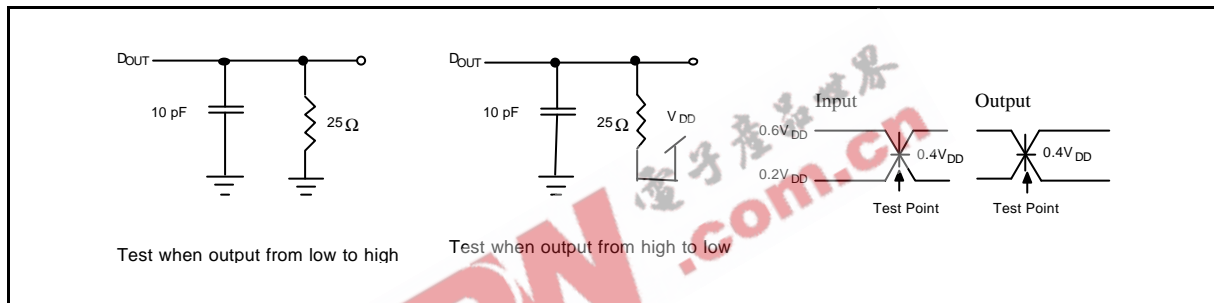

### Read/Write Cycle Timing Parameters

(V<sub>DD</sub> = 3.3V ± 5%, V<sub>GND</sub> = 0V, T<sub>A</sub> = 0 to 70° C)

PARAMETER	SYM.	W49V002A		UNIT
		MIN.	MAX.	
Clock Cycle Time	T <sub>CYC</sub>	30	-	nS
Input Set Up Time	T <sub>SU</sub>	7	-	nS
Input Hold Time	T <sub>HD</sub>	0	-	nS
Clock to Data Valid	T <sub>KQ</sub>	-	11	nS

### Reset Timing Parameters

PARAMETER	SYMBOL	MIN.	TYP.	MAX.	UNIT
V <sub>DD</sub> stable to Reset Active	T <sub>PRST</sub>	1	-	-	mS
Clock Stable to Reset Active	T <sub>KRST</sub>	100	-	-	μS
Reset Pulse Width	T <sub>RSTP</sub>	100	-	-	nS
Reset Active to Output Float	T <sub>RSTF</sub>	-	-	50	nS
Reset Inactive to Input Active	T <sub>RST</sub>	1	-	-	μS

Note: All AC timing signals observe the following guidelines for determining setup and hold times:

- (a) High level signal's reference level is input high and (b) low level signal's reference level is input low.
- Ref. to the AC testing condition.



## TIMING WAVEFORMS FOR LPC INTERFACE MODE

### Read Cycle Timing Diagram

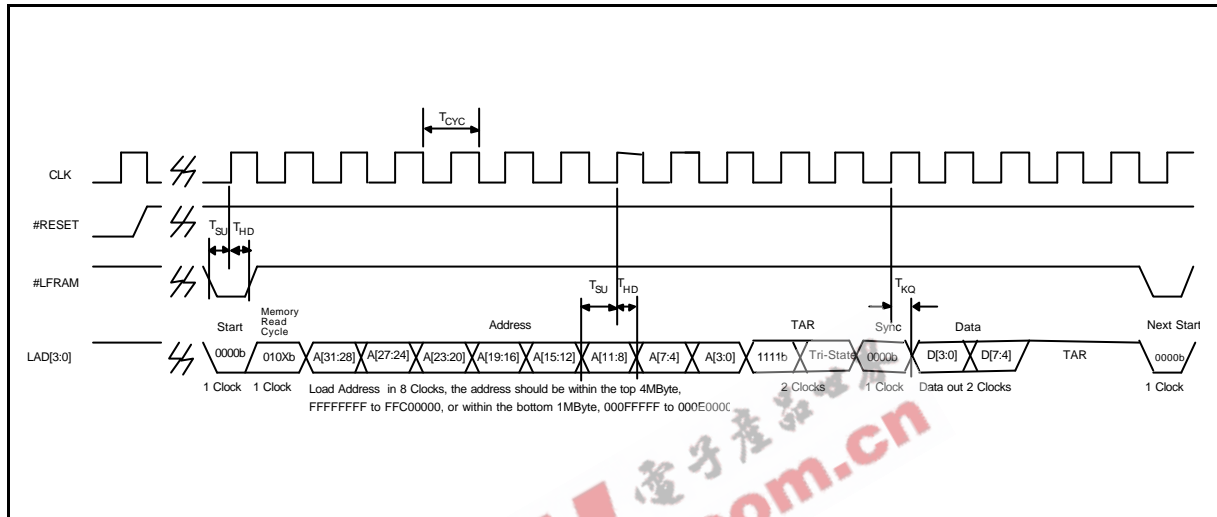

### Write Cycle Timing Diagram

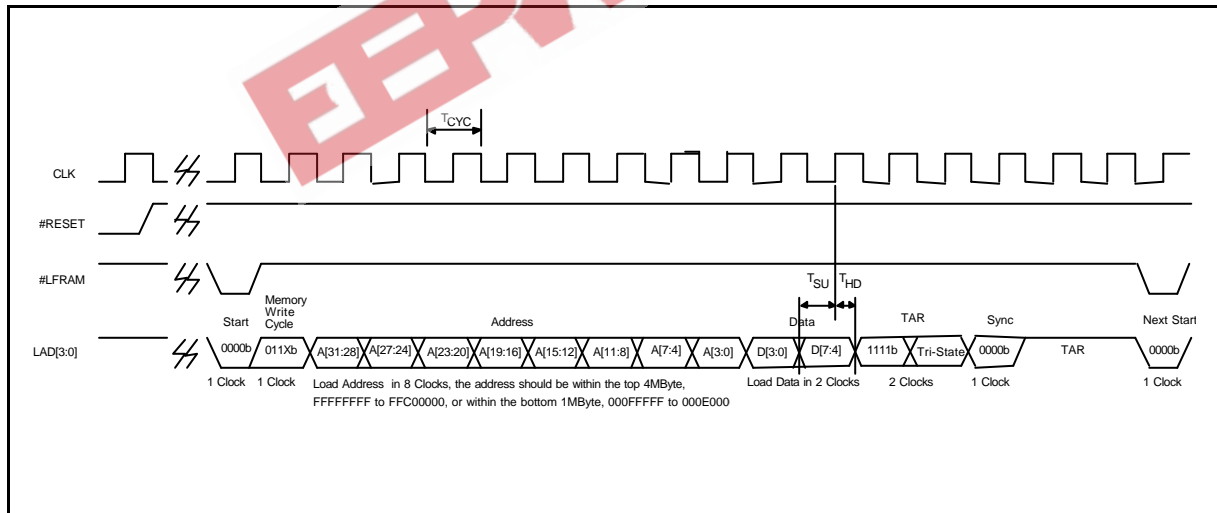



## Program Cycle Timing Diagram

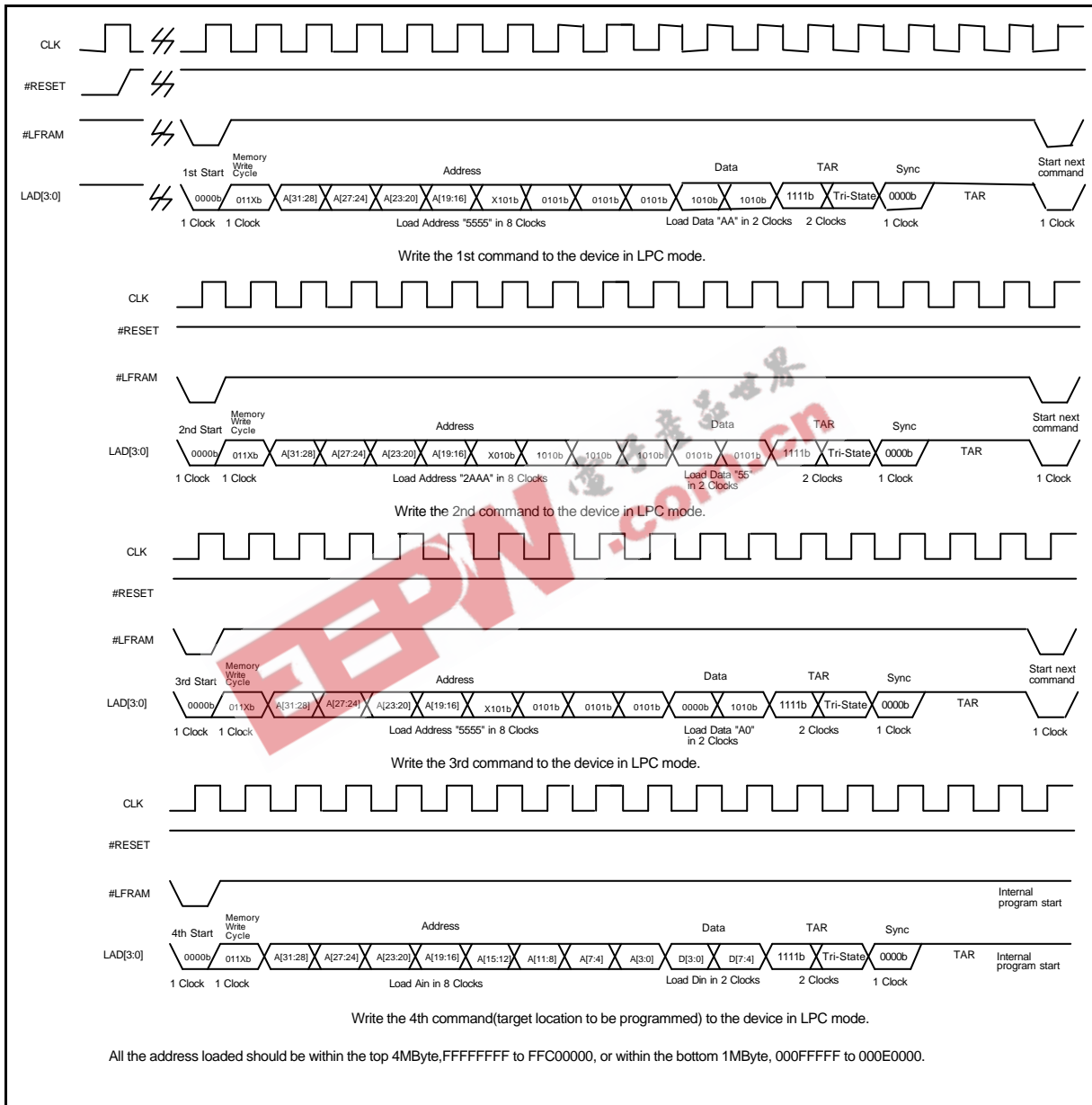



Timing Waveforms for LPC Interface Mode, continued

## #DATA Polling Timing Diagram

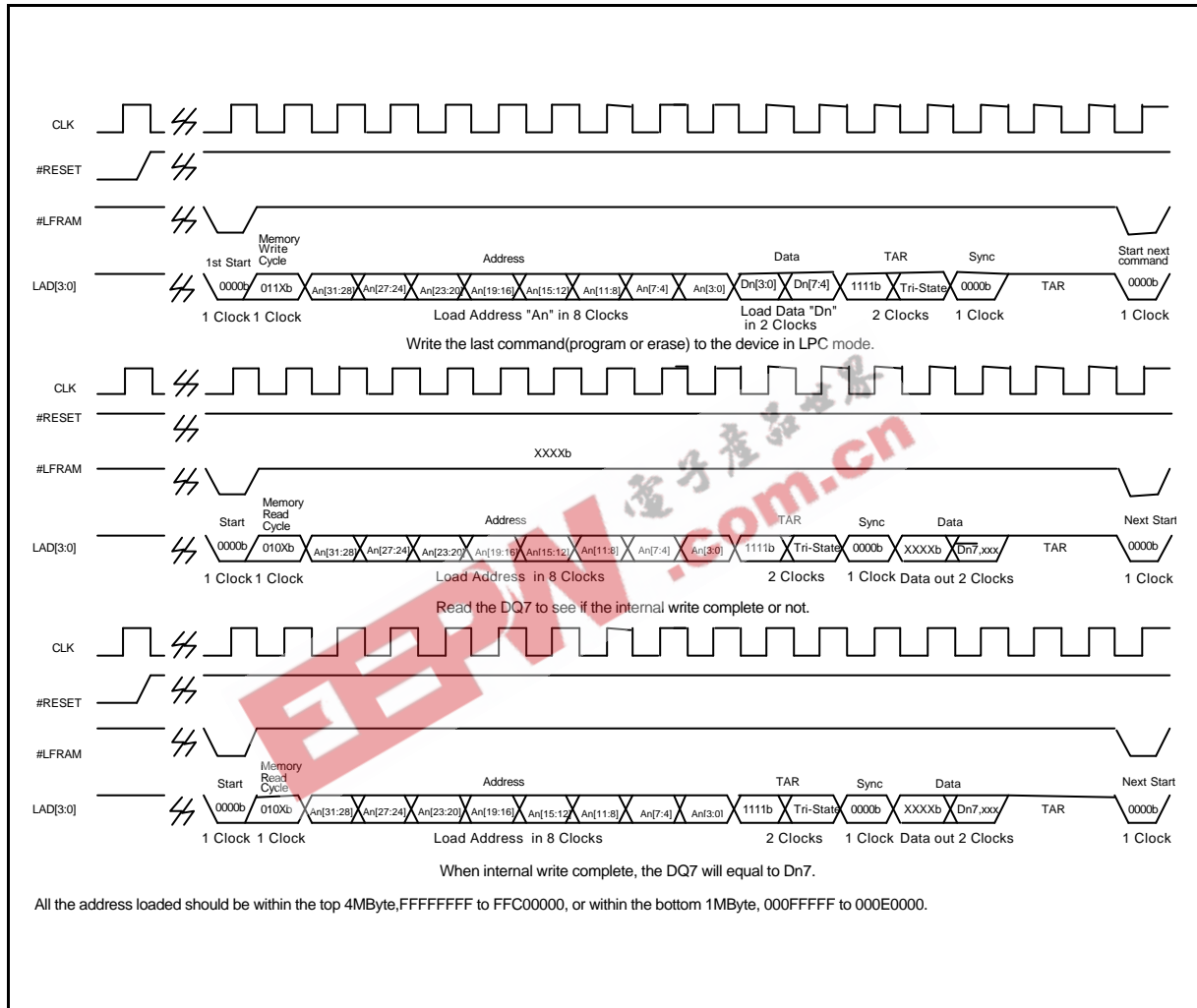





Timing Waveforms for LPC Interface Mode, continued

## Toggle Bit Timing Diagram

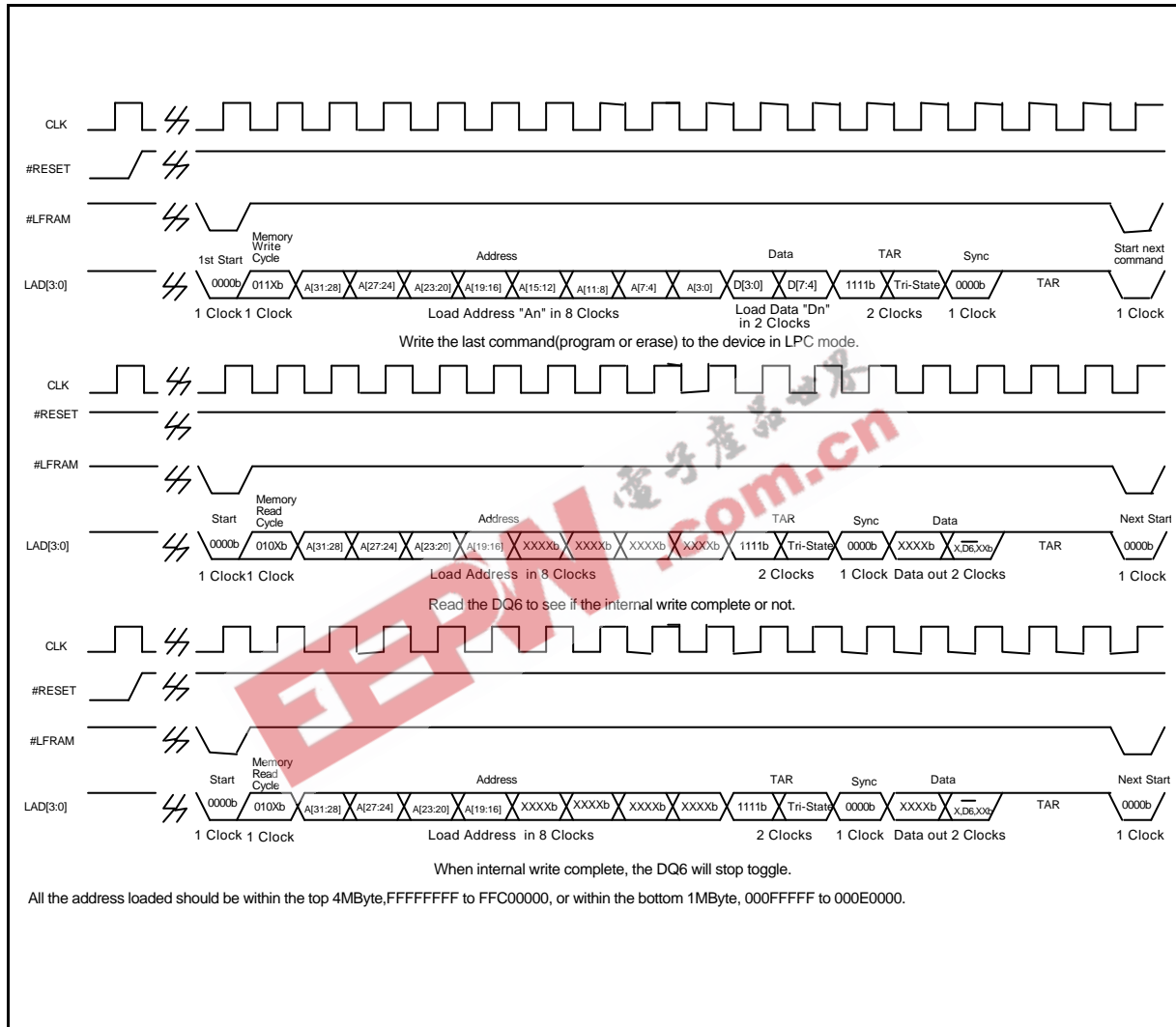



Timing Waveforms for LPC Interface Mode, continued

## Boot Block Lockout Enable Timing Diagram

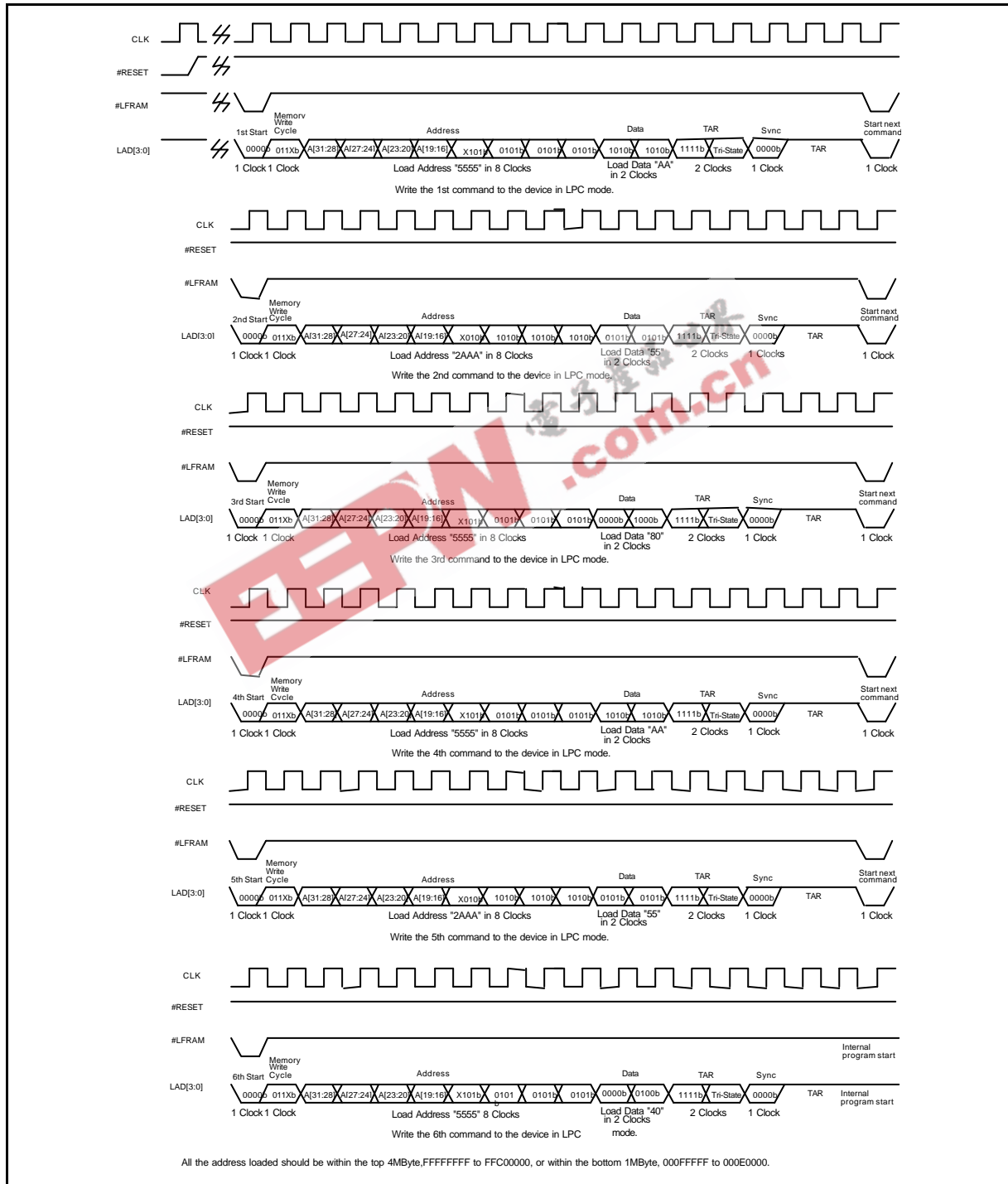



Timing Waveforms for LPC Interface Mode, continued

## Chip Erase Timing Diagram

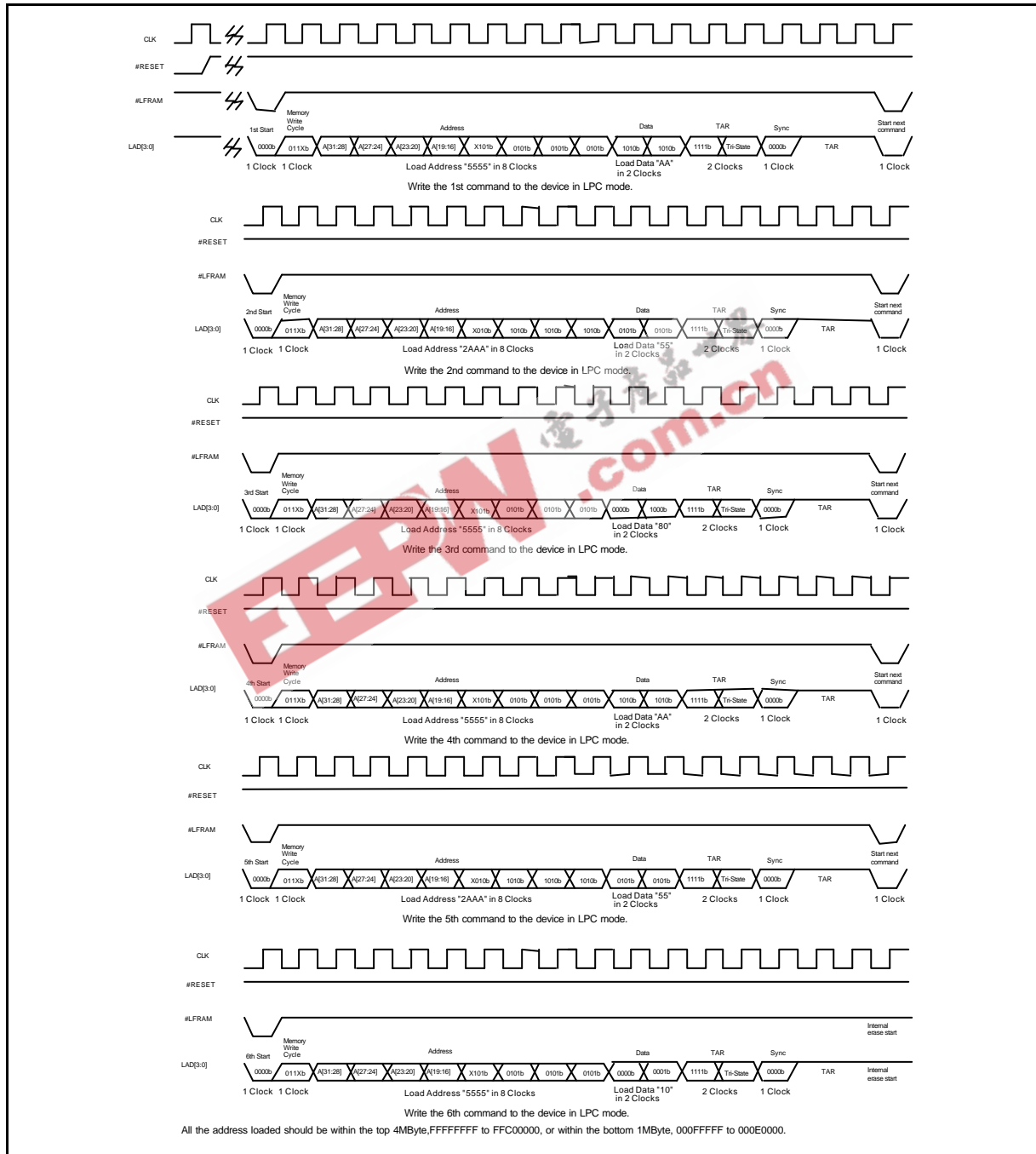



Timing Waveforms for LPC Interface Mode, continued

## Sector Erase Timing Diagram

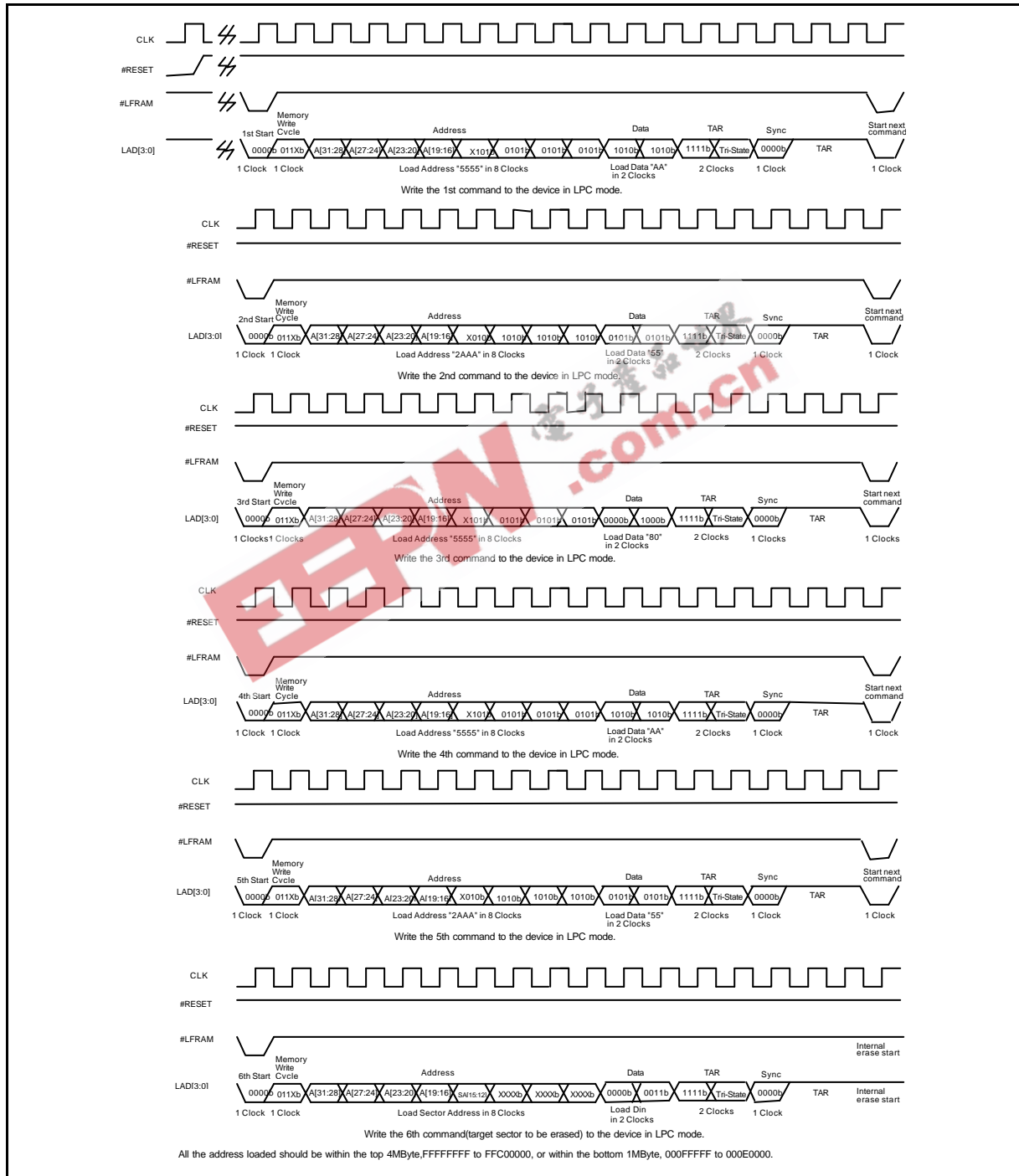

# Preliminary W49V002A



Timing Waveforms for LPC Interface Mode, continued

## GPI Register Readout Timing Diagram

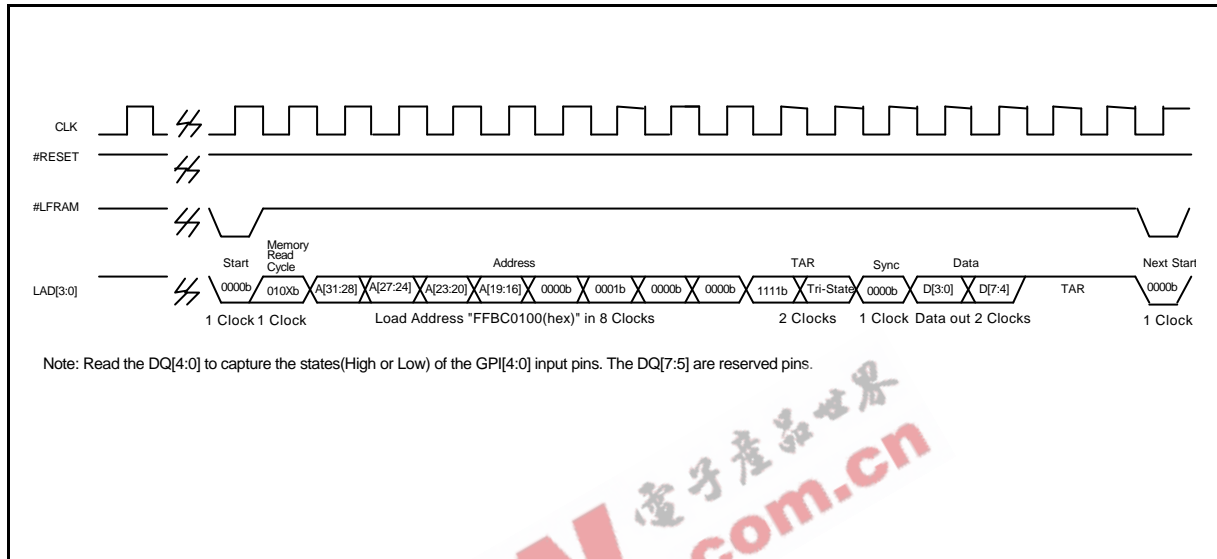

## Reset Timing Diagram

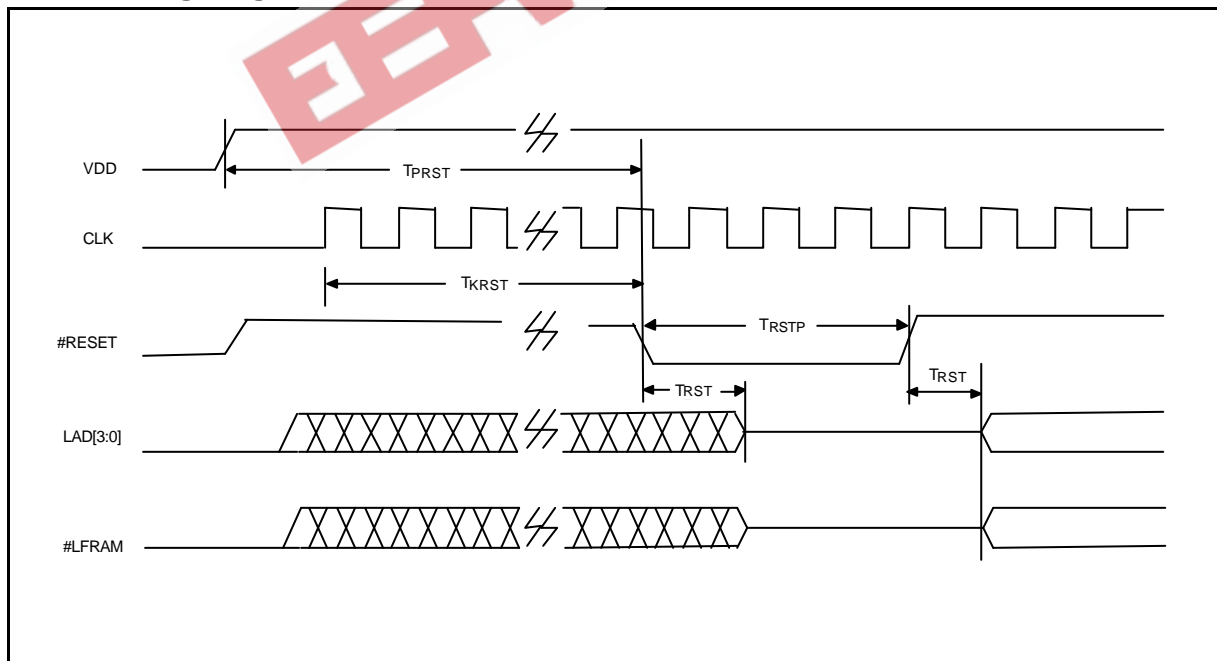

## Preliminary W49V002A



### ORDERING INFORMATION

PART NO.	ACCESS TIME (nS)	POWER SUPPLY CURRENT MAX. (mA)	STANDBY VDD CURRENT MAX. (mA)	PACKAGE
W49V002AP	11	25	20	32L PLCC
W49V002AQ	11	25	20	32L STSOP

Notes:

1. Winbond reserves the right to make changes to its products without prior notice.
2. Purchasers are responsible for performing appropriate quality assurance testing on products intended for use in applications where personal injury might occur as a consequence of product failure.

EEPW 电子产品世界  
.com.cn

# Preliminary W49V002A



## PACKAGE DIMENSIONS

### 32L PLCC

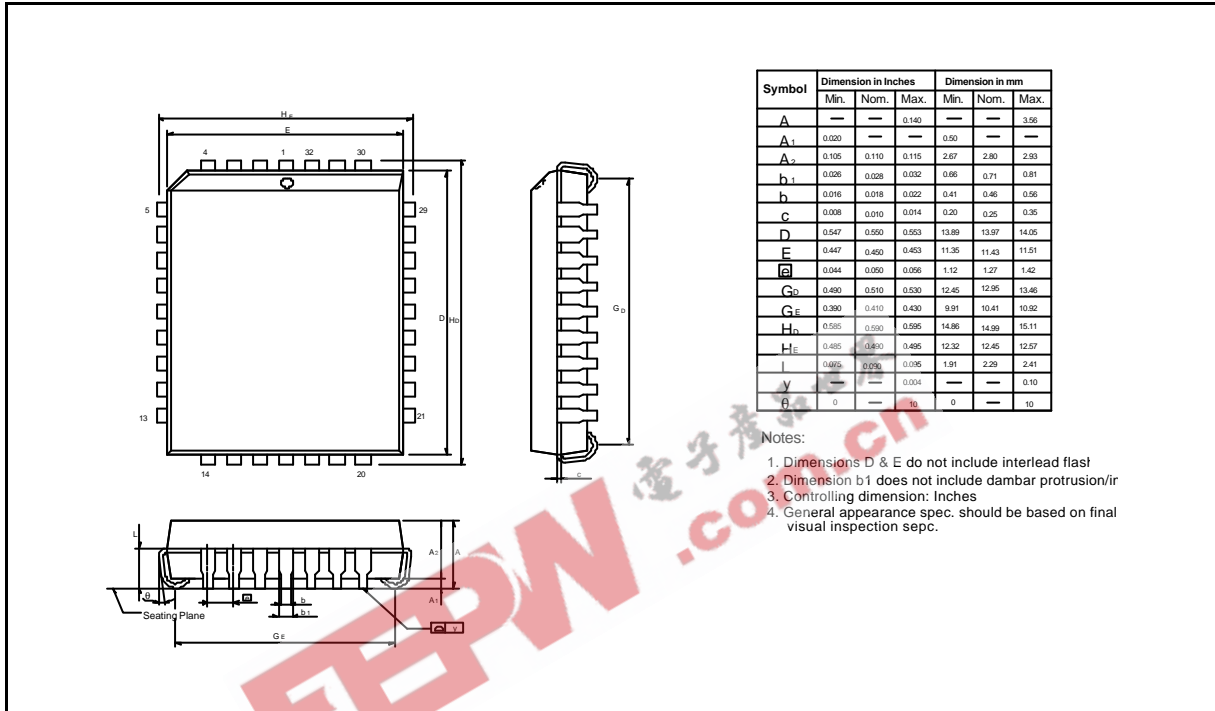

### 32L STSOP(8 x 14mm)

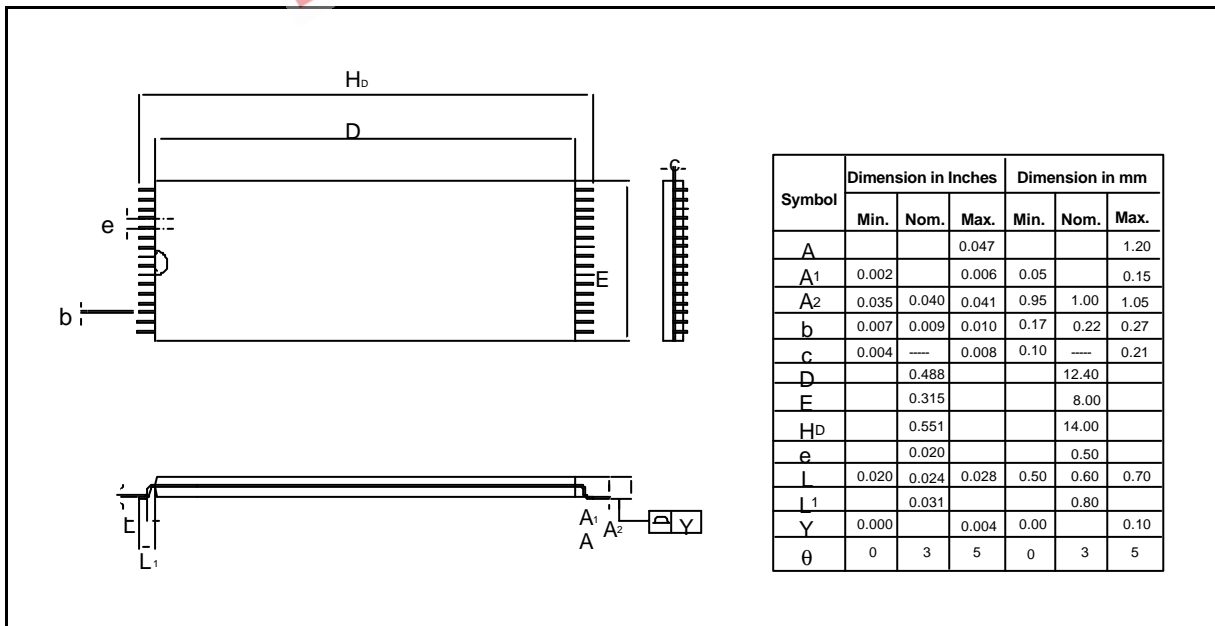

# Preliminary W49V002A



## VERSION HISTORY

VERSION	DATE	PAGE	DESCRIPTION
A1	Apr. 2001	-	Initial Issued

EEPW 电子產品世界 .com.cn



### Headquarters

No. 4, Creation Rd. III,  
ScienceBased Industrial Park,  
Hsinchu, Taiwan  
TEL: 886-3-5770066  
FAX: 886-3-5792766  
<http://www.winbond.com.tw/>  
Voice & Faxon-demand: 8862-27197006

### Taipei Office

11F, No. 115, Sec. 3, Muzhen East Rd.,  
Taipei, Taiwan  
TEL: 8862-27190505  
FAX: 8862-27197502

### Winbond Electronics (H.K.) Ltd.

Unit 915, 22F, Millennium City,  
No. 378 Kwun Tong Rd;  
Kowloon, Hong Kong  
TEL: 852-27513100  
FAX: 852-27552064

### Winbond Electronics North America Corp.

Winbond Memory Lab.  
Winbond Microelectronics Corp.  
Winbond Systems Lab.  
2727 N. First Street, San Jose,  
CA 95134, U.S.A.  
TEL: 408-9436666  
FAX: 408-5441798

Note: All data and specifications are subject to change without notice.