

W24L01



128K × 8 CMOS STATIC RAM

GENERAL DESCRIPTION

The W24L01 is a normal-speed, very low-power CMOS static RAM organized as 131072 × 8 bits that operates on a wide voltage range from 2.7V to 3.6V power supply. The W24L01 family, W24L01-LE and W24L01-LI, can meet the requirement of various operating temperature. This device is manufactured using Winbond's high performance CMOS technology.

FEATURES

- Low power consumption
- Access time: 55 nS /70 nS
- 2.7V to 3.6V supply voltage
- Fully static operation
- All inputs and outputs directly TTL compatible
- Three-state outputs
- Battery back-up operation capability
- Data retention voltage: 1.5V (min.)
- Packaged in 32-pin 450 mil SOP, standard type one TSOP (8 mm × 20 mm), small type one TSOP (8 mm × 13.4 mm) and 48-pin CSP

PIN CONFIGURATIONS

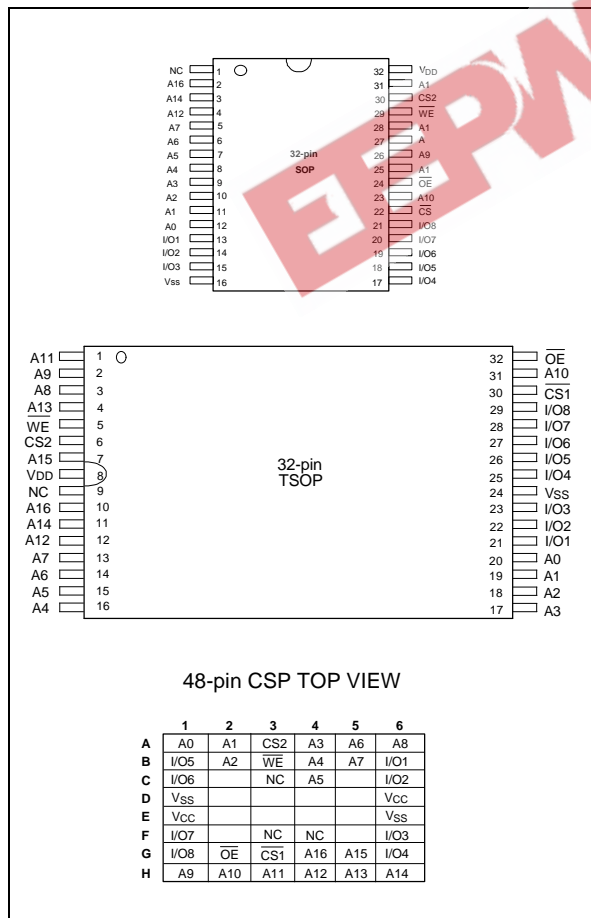

BLOCK DIAGRAM

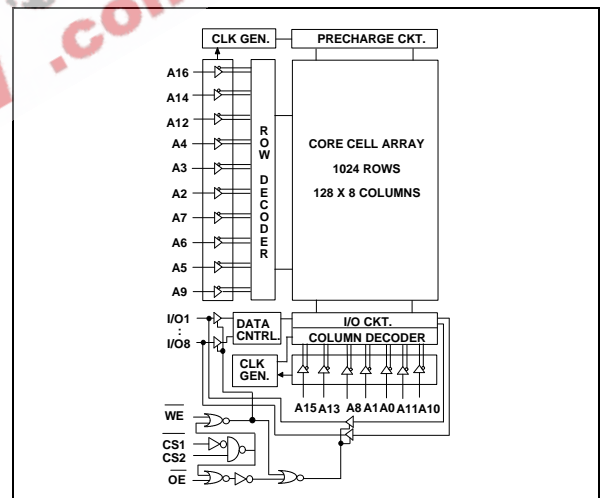

PIN DESCRIPTION

SYMBOL	DESCRIPTION
A0 – A16	Address Inputs
I/O1 – I/O8	Data Inputs/Outputs
CS, CS2	Chip Select Input
WE	Write Enable Input
OE	Output Enable Input
VDD	Power Supply
VSS	Ground
NC	No Connection



TRUTH TABLE

$\overline{CS1}$	CS2	\overline{OE}	\overline{WE}	MODE	I/O1- I/O8	VDD CURRENT
H	X	X	X	Not Selected	High Z	ISB, ISB1
X	L	X	X	Not Selected	High Z	ISB, ISB1
L	H	H	H	Output Disable	High Z	IDD
L	H	L	H	Read	Data Out	IDD
L	H	X	L	Write	Data In	IDD

DC CHARACTERISTICS

Absolute Maximum Ratings

PARAMETER	RATING	UNIT
Supply Voltage to VSS Potential	-0.5 to +4.6	V
Input/Output to VSS Potential	-0.5 to VDD +0.5	V
Allowable Power Dissipation	1.0	W
Storage Temperature	-65 to +150	°C
Operating Temperature	LL	0 to 70
	LE	-20 to 85
	LI	-40 to 85

Note: Exposure to conditions beyond those listed under Absolute Maximum Ratings may adversely affect the life and reliability of the device.

Operating Characteristics

(VSS = 0V; TA (°C) = 0 to 70 for LL, -20 to 85 for LE, -40 to 85 for LI)

PARAMETER	SYM.	TEST CONDITIONS	W24L01			UNIT
			MIN.	TYP.*	MAX.	
Input Low Voltage	VIL	-	-0.2	-	+0.4	V
Input High Voltage	VIH	-	+2.2	-	VDD +0.3	V
Input Leakage Current	ILI	VIN = VSS to VDD	-1	-	+1	μA
Output Leakage Current	ILO	VI/O = VSS to VDD, $\overline{CS1}$ = VIH (min.) or CS2 = VIL (max.) or \overline{OE} = VIH (min.) or \overline{WE} = VIL (max.)	-1	-	+1	μA
Output Low Voltage	VOL	IOL = +2.1 mA	-	-	0.4	V
Output High Voltage	VOH	IOH = -1.0 mA	2.2	-	-	V



Operating Characteristics, continued

PARAMETER	SYM.	TEST CONDITIONS	W24L01			UNIT
			MIN.	TYP.*	MAX.	
Operating Power Supply Current	I _{DD}	$\overline{CS1} = V_{IL} \text{ (max.)}$ and $CS2 = V_{IH} \text{ (min.)}$, I/O = 0 mA, Cycle = min. Duty = 100%	-	25 (3V) 30 (3.3V)	40 (70 nS) 55 (55 nS)	mA
Standby Power Supply Current	ISB	$\overline{CS1} = V_{IH} \text{ (min.)}$ or $CS2 = V_{IL} \text{ (max.)}$, Cycle = min. Duty = 100%	-	-	0.3	mA
	ISB1	$\overline{CS1} \geq V_{DD} - 0.2V$ or $CS2 \leq 0.2V$	LL LE/LI	-	2 5 7	μA

Note: Typical parameter is measured under ambient temperature T_A = 25° C

CAPACITANCE

(T_A = 25° C, f = 1 MHz)

PARAMETER	SYM.	CONDITIONS	MAX.	UNIT
Input Capacitance	C _{IN}	V _{IN} = 0V	8	pF
Input/Output Capacitance	C _{IO}	V _{OUT} = 0V	10	pF

Note: These parameters are sampled but not 100% tested.

AC CHARACTERISTICS

AC Test Conditions

PARAMETER	CONDITIONS
Input Pulse Levels	0V to 2.2V
Input Rise and Fall Times	5 nS
Input and Output Timing Reference Level	1.5V, V _{DD} = 3.0V
Output Load	See the drawing below

AC Test Loads and Waveform

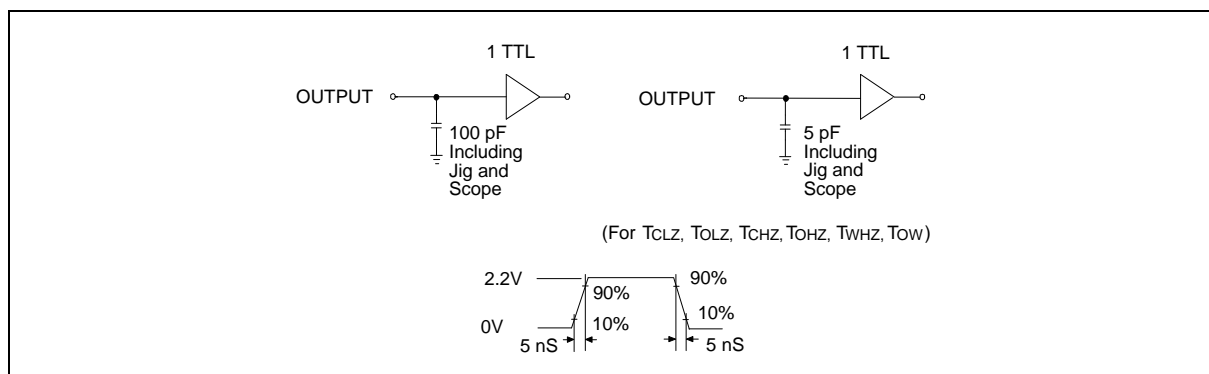



AC Characteristics, continued

(V_{SS} = 0V; T_A (°C) = 0 to 70 for LL, -20 to 85 for LE, -40 to 85 for LI)**Read Cycle**

PARAMETER	SYM.	MIN.	MAX.	MIN.	MAX.	UNIT
Read Cycle Time	TRC	55	-	70	-	nS
Address Access Time	TAA	-	55	-	70	nS
Chip Select Access Time	TACS	-	55	-	70	nS
Output Enable to Output Valid	TAOE	-	30	-	35	nS
Chip Selection to Output in Low Z	TCLZ*	10	-	10	-	nS
Output Enable to Output in Low Z	TOLZ*	5	-	5	-	nS
Chip Deselection to Output in High Z	TCHZ*	-	25	-	30	nS
Output Disable to Output in High Z	TOHZ*	-	25	-	30	nS
Output Hold from Address Change	TOH	5	-	10	-	nS

* These parameters are sampled but not 100% tested

Write Cycle

PARAMETER	SYM.	MIN.	MAX.	MIN.	MAX.	UNIT
Write Cycle Time	TWC	55	-	70	-	nS
Chip Selection to End of Write	TCW	50	-	60	-	nS
Address Valid to End of Write	TAW	50	-	60	-	nS
Address Setup Time	TAS	0	-	0	-	nS
Write Pulse Width	TWP	40	-	55	-	nS
Write Recovery Time	$\overline{CS1}$, $CS2$, \overline{WE}	TWR	0	-	0	nS
Data Valid to End of Write	TDW	30	-	30	-	nS
Data Hold from End of Write	TDH	0	-	0	-	nS
Write to Output in High Z	TWHZ*	-	20	-	25	nS
Output Disable to Output in High Z	TOHZ*	-	20	-	25	nS
Output Active from End of Write	TOW	5	-	5	-	nS

* These parameters are sampled but not 100% tested



TIMING WAVEFORMS

Read Cycle 1

(Address Controlled)

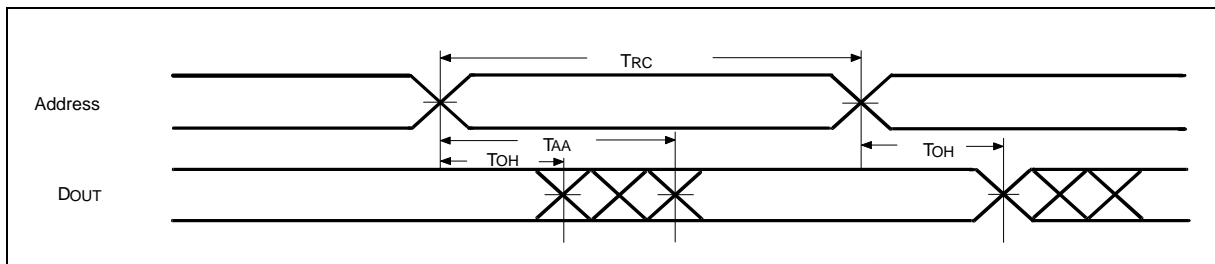

Read Cycle 2

(Chip Select Controlled)

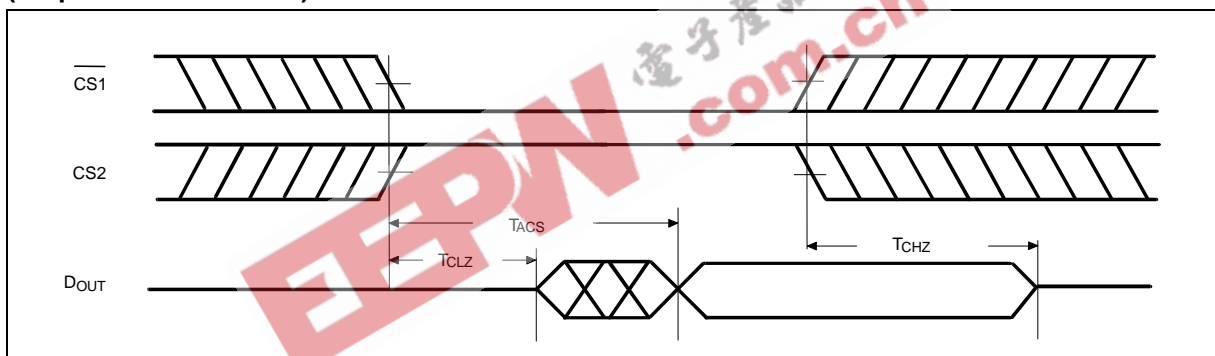

Read Cycle 3

(Output Enable Controlled)

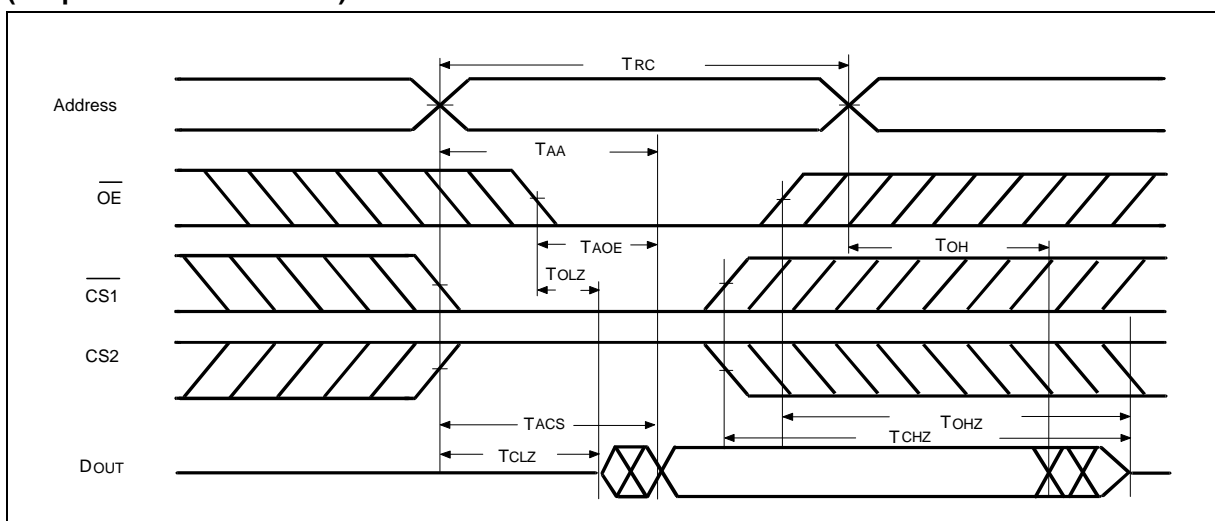



Timing Waveforms, continued

Write Cycle 1

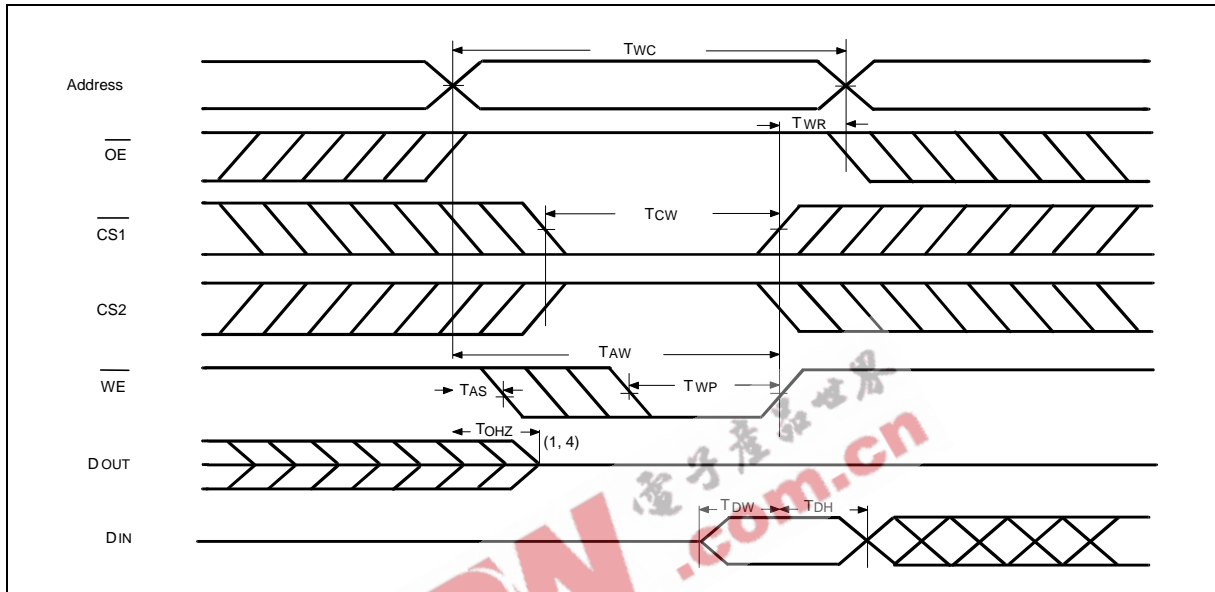

Write Cycle 2

(OE = VIL Fixed)

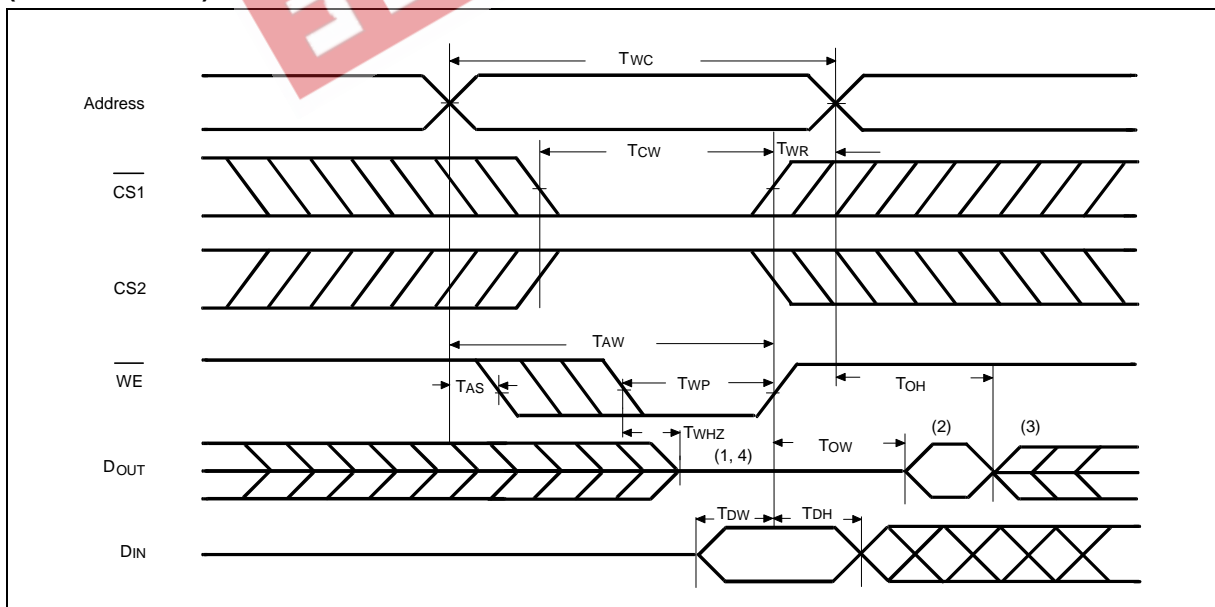

Notes:

1. During this period, I/O pins are in the output state, so input signals of opposite phase to the outputs should not be applied.
2. The data output from DOUT are the same as the data written to DIN during the write cycle.
3. DOUT provides the read data for the next address.
4. Transition is measured ± 500 mV from steady state with $C_L = 5$ pF. This parameter is guaranteed but not 100% tested.



DATA RETENTION CHARACTERISTICS

(TA (°C) = 0 to 70 for LL, -20 to 85 for LE; -40 to 85 for LI)

PARAMETER	SYM.	TEST CONDITIONS	MIN.	TYP.	MAX.	UNIT
VDD for Data Retention	VDR	$\overline{CS1} \geq VDD - 0.2V$ or $CS2 \leq 0.2V$	1.5	-	-	V
Data Retention Current	I _{DDDR}	$\overline{CS1} \geq VDD - 0.2V$ or $CS2 \leq 0.2V, VDD = 3V$	-	-	5	μA
Chip Deselect to Data Retention Time	T _{CDR}	See data retention waveform	0	-	-	nS
Operation Recovery Time	T _R		TRC*	-	-	nS

* Read Cycle Time

DATA RETENTION WAVEFORM

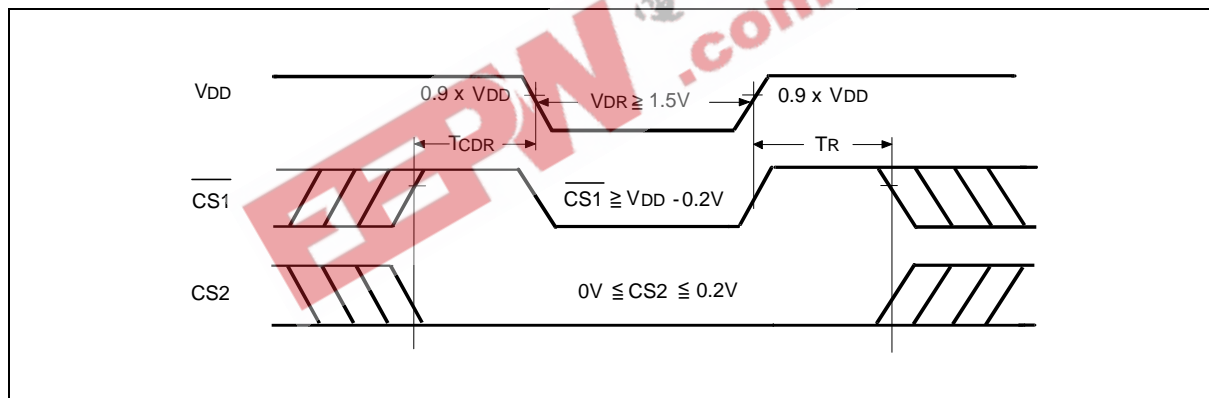



ORDERING INFORMATION

PART NO.	ACCESS TIME (nS)	OPERATING VOLTAGE (V)	OPERATING TEMPERATURE (°C)	PACKAGE
W24L01B-55LL	55	2.7V – 3.6V	0 to 70	CSP
W24L01Q-55LL	55	2.7V – 3.6V	0 to 70	Small type one TSOP
W24L01S-55LL	55	2.7V – 3.6V	0 to 70	450 mil SOP
W24L01T-55LL	55	2.7V – 3.6V	0 to 70	Standard type one TSOP
W24L01B-55LE	55	2.7V – 3.6V	-20 to 85	CSP
W24L01Q-55LE	55	2.7V – 3.6V	-20 to 85	Small type one TSOP
W24L01S-55LE	55	2.7V – 3.6V	-20 to 85	450 mil SOP
W24L01T-55LE	55	2.7V – 3.6V	-20 to 85	Standard type one TSOP
W24L01B-55LI	55	2.7V – 3.6V	-40 to 85	CSP
W24L01Q-55LI	55	2.7V – 3.6V	-40 to 85	Small type one TSOP
W24L01S-55LI	55	2.7V – 3.6V	-40 to 85	450 mil SOP
W24L01T-55LI	55	2.7V – 3.6V	-40 to 85	Standard type one TSOP
W24L01B-70LL	70	2.7V – 3.6V	0 to 70	CSP
W24L01Q-70LL	70	2.7V – 3.6V	0 to 70	Small type one TSOP
W24L01S-70LL	70	2.7V – 3.6V	0 to 70	450 mil SOP
W24L01T-70LL	70	2.7V – 3.6V	0 to 70	Standard type one TSOP
W24L01B-70LE	70	2.7V – 3.6V	-20 to 85	CSP
W24L01Q-70LE	70	2.7V – 3.6V	-20 to 85	Small type one TSOP
W24L01S-70LE	70	2.7V – 3.6V	-20 to 85	450 mil SOP
W24L01T-70LE	70	2.7V – 3.6V	-20 to 85	Standard type one TSOP
W24L01B-70LI	70	2.7V – 3.6V	-40 to 85	CSP
W24L01Q-70LI	70	2.7V – 3.6V	-40 to 85	Small type one TSOP
W24L01S-70LI	70	2.7V – 3.6V	-40 to 85	450 mil SOP
W24L01T-70LI	70	2.7V – 3.6V	-40 to 85	Standard type one TSOP

Notes:

1. Winbond reserves the right to make changes to its products without prior notice.
2. Purchasers are responsible for performing appropriate quality assurance testing on products intended for use in applications where personal injury might occur as a consequence of product failure.



PACKAGE DIMENSIONS

32-pin Small Type One TSOP

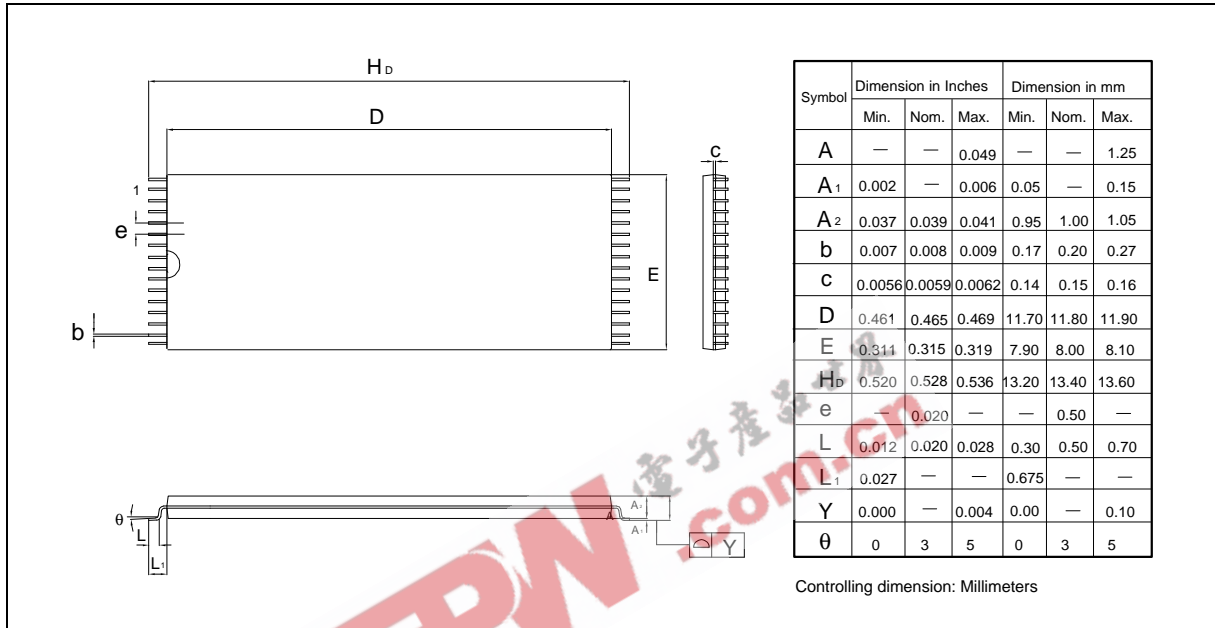

32-pin SOP Wide Body

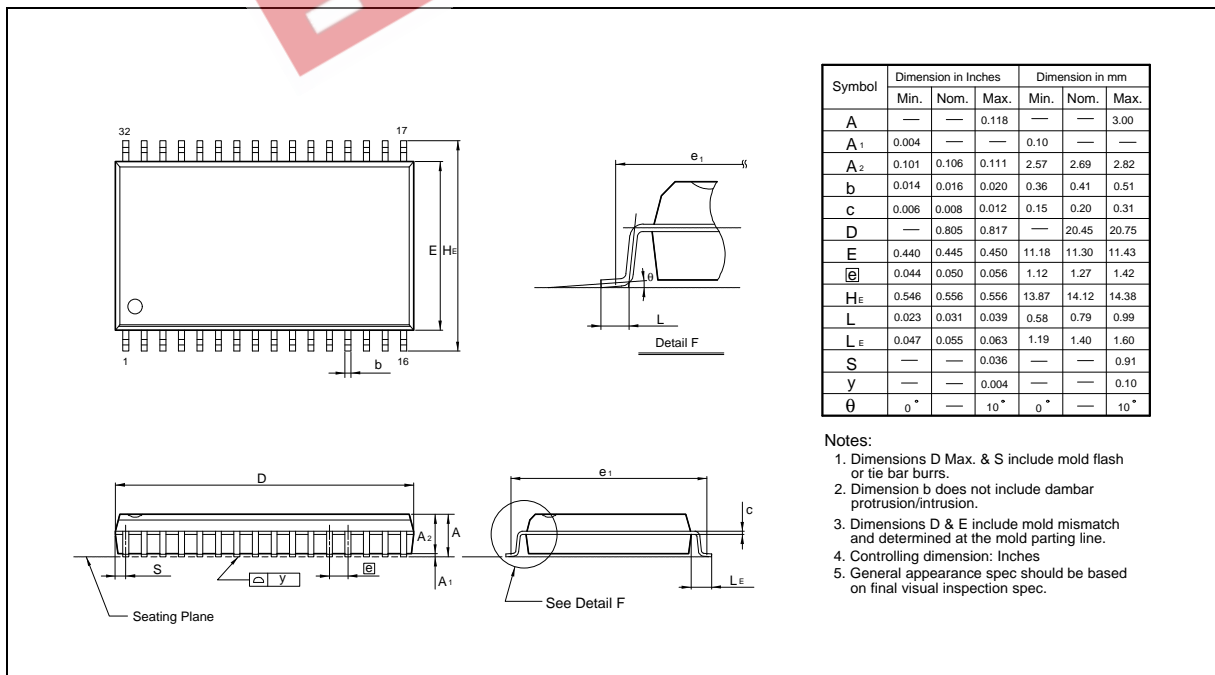



Package Dimensions, continued

32-pin Standard Type One TSOP

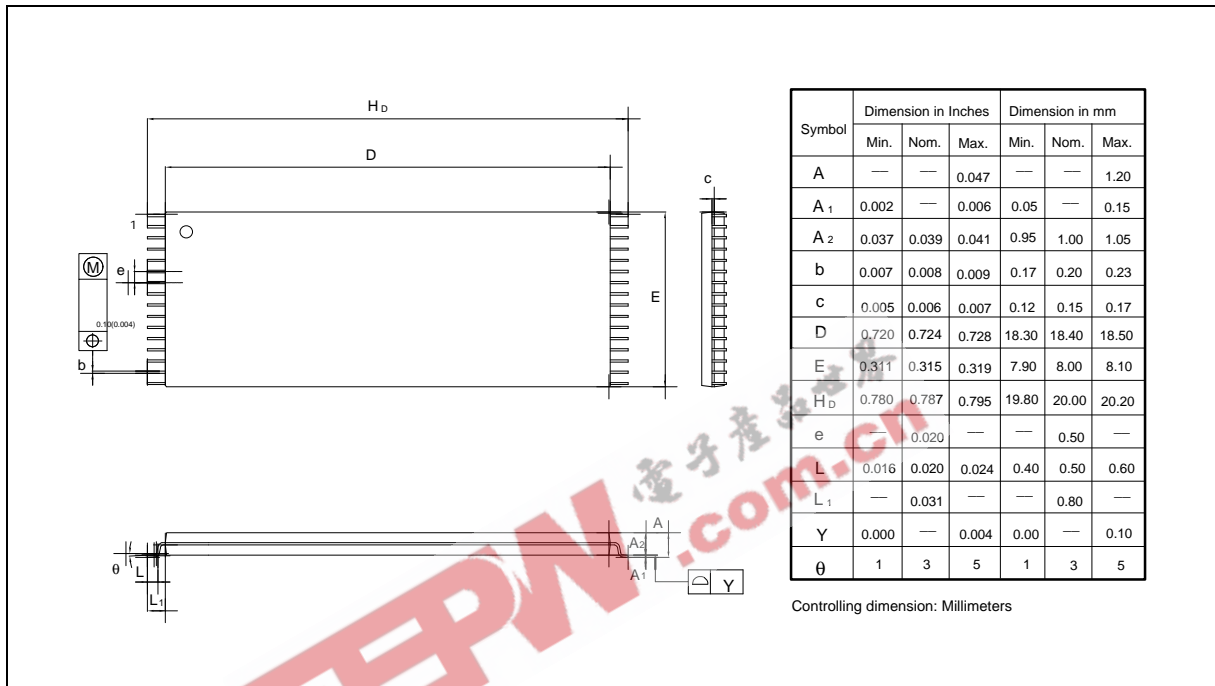



VERSION HISTORY

VERSION	DATE	DESCRIPTION
A1	Feb. 1998	Initial Issued
A2	Apr. 1998	Add standby power supply current (ISB1) typical parameter when operation temperature TA = 25° C
A3	June 1998	Change supply voltage range from (2.7V to 3.6V) to (2.3V to 3.3V)
A4	Oct. 1998	Add SOP package type
A5	Jan. 1999	Add SOP package pin configuration
A6	Jan. 2, 2002	Change supply voltage range from (2.3V – 3.3V) to (2.7V – 3.6V). Add 55 nS spec. Add LL grade.

EEPW.com.cn 電子產品世界

**Headquarters**

No. 4, Creation Rd. III,
Science-Based Industrial Park,
Hsinchu, Taiwan
TEL: 886-3-5770066
FAX: 886-3-5665577
<http://www.winbond.com.tw/>

Taipei Office

11F, No. 115, Sec. 3,
Min-Sheng East. Rd.,
Taipei, Taiwan
TEL: 886-2-27190505
FAX: 886-2-27197502

Winbond Electronics Corporation America

2727 North First Street, San Jose,
CA 95134, U.S.A.
TEL: 1-408-9436666
FAX: 1-408-5441798

Winbond Electronics Corporation Japan

7F Daini-ueno BLDG, 3-7-18
Shinyokohama Kohoku-ku,
Yokohama, 222-0033
TEL: 81-45-4781881
FAX: 81-45-4781800

Winbond Electronics (Shanghai) Ltd.

27F, 2299 Yan An W. Rd. Shanghai,
200336 China
TEL: 86-21-62365999
FAX: 86-21-62365998

Winbond Electronics (H.K.) Ltd.

Unit 9-15, 22F, Millennium City,
No. 378 Kwun Tong Rd.,
Kowloon, Hong Kong
TEL: 852-27513100
FAX: 852-27552064

Please note that all data and specifications are subject to change without notice.
All the trade marks of products and companies mentioned in this data sheet belong to their respective owners.