



# Z86C90/C89

## ROMLESS CMOS

### Z8<sup>®</sup> 8-BIT MICROCONTROLLER

#### GENERAL DESCRIPTION

The Z86C90/C89 CCP™ (Consumer Controller Processor) introduces a new level of sophistication to single-chip architecture. The Z86C90/C89 are ROMless members of the Z8 single-chip microcontroller family with 236 bytes of general purpose RAM. The only difference that exists between the Z86C89 and the Z86C90 is that the on-chip oscillator of the Z86C89 can accept an external RC network or other external clock source, while the Z86C90's on-chip oscillator accepts a crystal, ceramic resonator, LC, or external clock source drive. The CCP controllers are housed in a 40-pin DIP, 44-pin Leaded Chip Carrier, or a 44-pin Quad Flat Pack, and are CMOS compatible. The CCP offers the use of external memory which enables this Z8 microcomputer to be used where code flexibility is required. Zilog's CMOS microcomputer offers fast execution, efficient use of memory, sophisticated interrupts, input/output bit manipulation capabilities, and easy hardware/software system expansion along with low cost and low power consumption.

The Z86C90/C89 architecture is based on Zilog's 8-bit microcontroller core with an Expanded Register File to allow access to register mapped peripheral and I/O circuits. The CCP offers a flexible I/O scheme, an efficient register and address space structure, and a number of ancillary features that are useful in many industrial, automotive, computer peripherals, and advanced scientific applications.

The CCP applications demand powerful I/O capabilities. The Z86C90/C89 fulfills this with 32 pins dedicated to input and output. These lines are grouped into four ports. Each port consists of eight lines, and is configurable under software control to provide timing, status signals, parallel I/O with or without handshake, and an address/data bus for interfacing external memory.

There are four basic address spaces available to support this wide range of configurations: Program Memory, Register File, Data Memory, and Expanded Register File. The Register File is composed of 236 bytes of general purpose registers, four I/O port registers, and fifteen control and status registers. The Expanded Register File consists of two control registers.

To unburden the program from coping with the real-time problems, such as counting/timing and data communication, the Z86C90/C89 offers two on-chip counter/timers. Included are a large number of user selectable modes, and two on-board comparators to process analog signals with a common reference voltage (see Functional Block Diagram).

#### Notes:

All Signals with a preceding front slash, "/", are active Low, e.g.: B//W (WORD is active Low); /B/W (BYTE is active Low, only).

Power connections follow conventional descriptions below:

Connection	Circuit	Device
Power	V <sub>CC</sub>	V <sub>DD</sub>
Ground	GND	V <sub>SS</sub>

**GENERAL DESCRIPTION** (Continued)

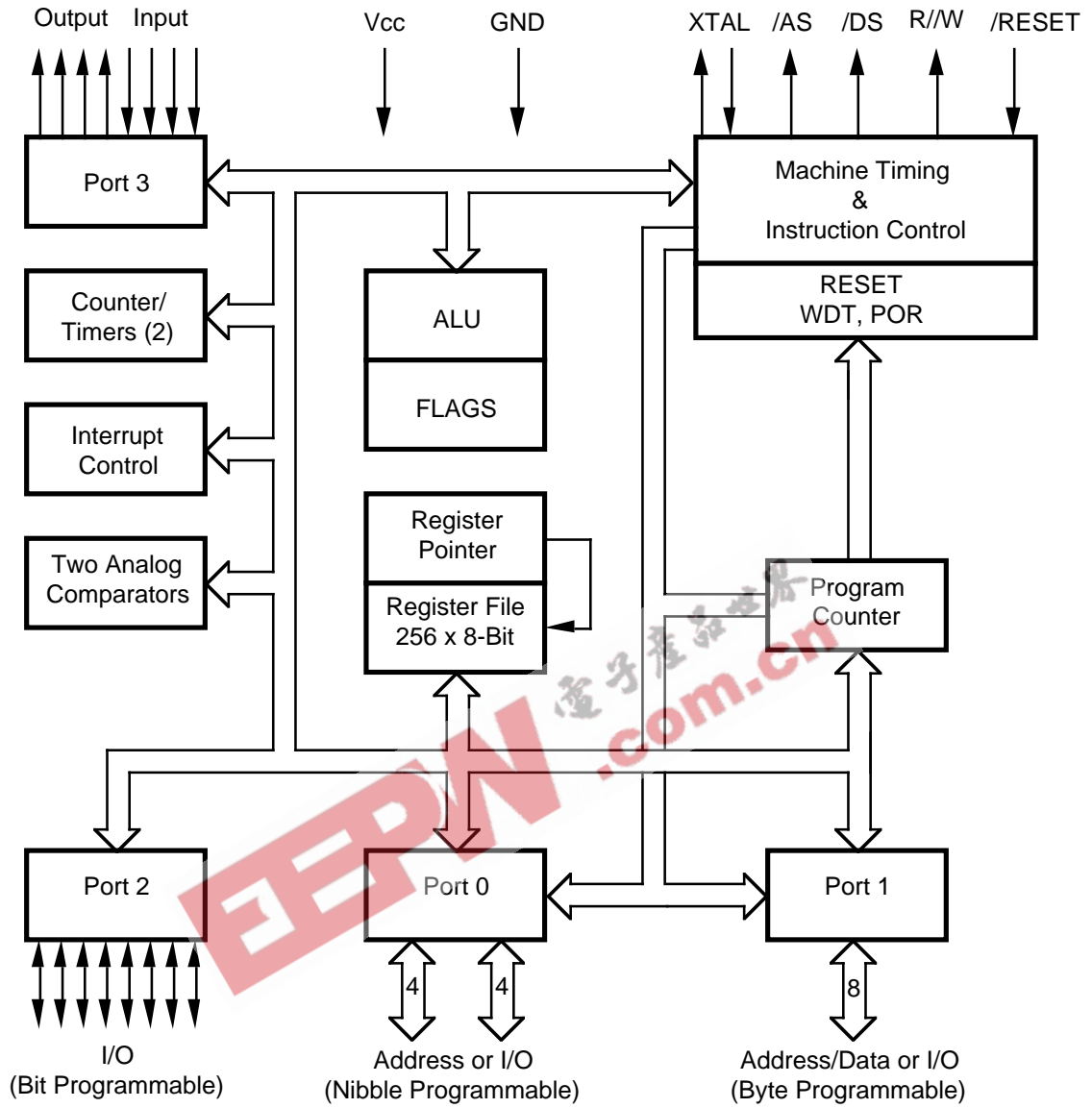

**Functional Block Diagram**

---

## PIN DESCRIPTION

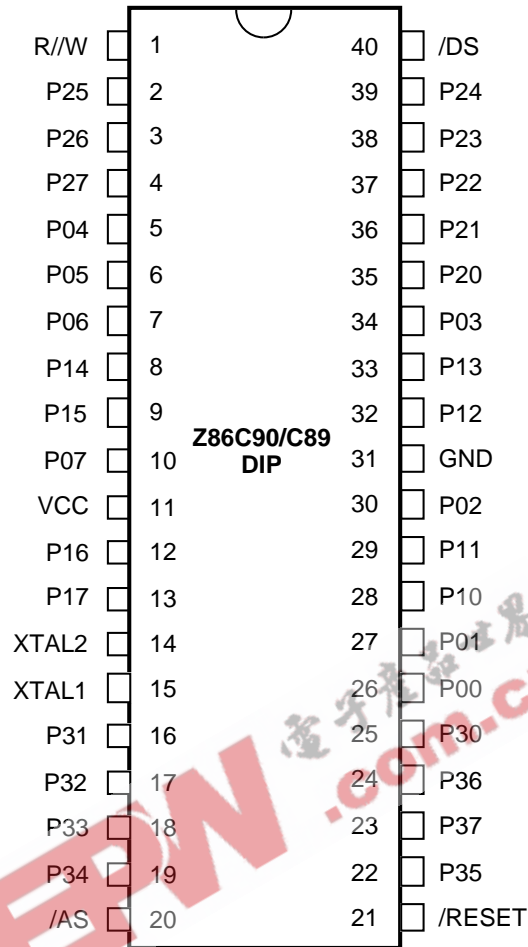

**40-Pin DIP Pin Assignments**

**PIN DESCRIPTION (Continued)**

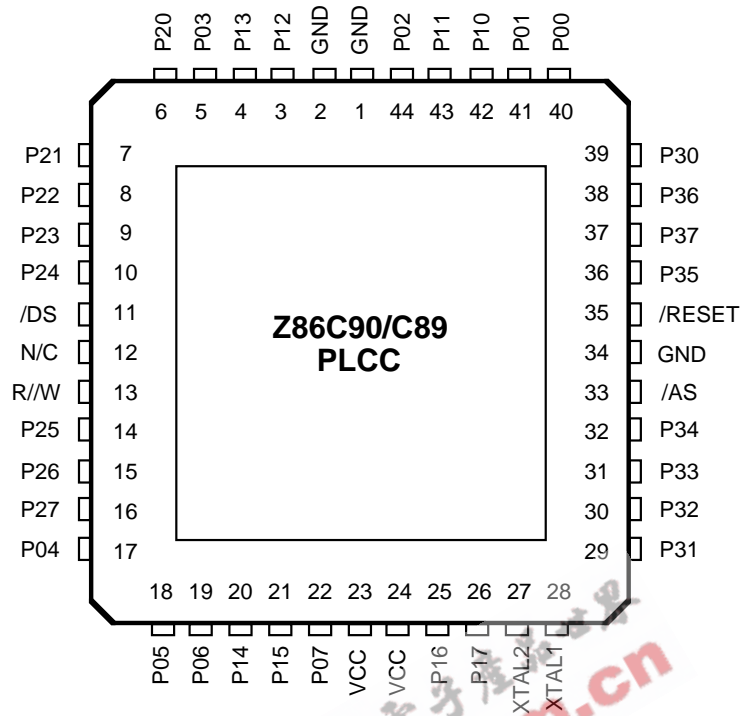

**44-Pin PLCC Pin Assignments**

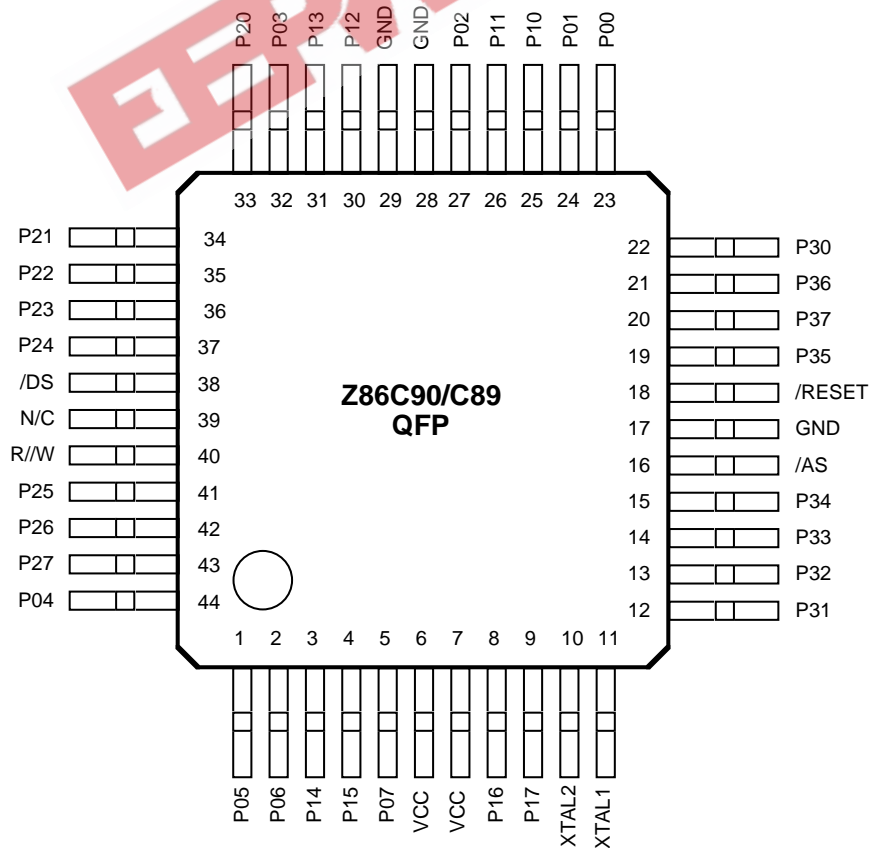

**44-Pin QFP Pin Assignments**

## STANDARD TEST CONDITIONS

The characteristics listed below apply for standard test conditions as noted. All voltages are referenced to GND. Positive current flows into the referenced pin (Test Load Diagram).

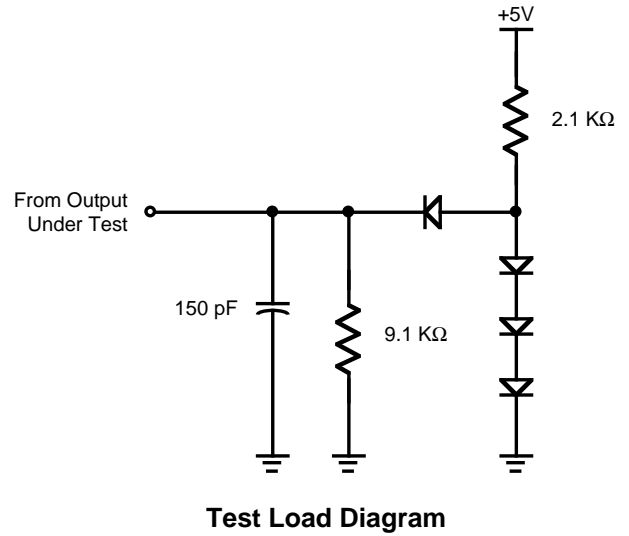

## ABSOLUTE MAXIMUM RATINGS

Symbol	Description	Min	Max	Units
$V_{CC}$	Supply Voltage (*)	-0.3	+7.0	V
$T_{STG}$	Storage Temp	-65°	+150°	C
$T_A$	Oper Ambient Temp	†		C
	Power Dissipation		2.2	W

**Notes:**  
 † See Ordering Information.

ings may cause permanent damage to the device. This is a stress rating only; operation of the device at any condition above those indicated in the operational sections of these specifications is not implied. Exposure to absolute maximum rating conditions for an extended period may affect device reliability.

Stress greater than those listed under Absolute Maximum Rat-

## CAPACITANCE

$T_A = 25^\circ\text{C}$ ,  $V_{CC} = \text{GND} = 0\text{V}$ ,  $f = 1.0\text{ MHz}$ , unmeasured pins to GND

Parameter	Max
Input capacitance	12 pF
Output capacitance	12 pF
I/O capacitance	12 pF

## PLEASE NOTE

These devices will not operate in extended timing mode. Set Register 248, D5 = 0.

## DC CHARACTERISTICS

Sym Notes	Parameter	V <sub>CC</sub>  Note [3]	T <sub>A</sub> = 0°C		T <sub>A</sub> = -40° C		Typ @ 25°C	Units	Conditions
			Min	Max	Min	Max			
V <sub>CH</sub>	Max Input Voltage	3.3V	7		7			V	I <sub>IN</sub> 250μA
		5.0V	7		7			V	I <sub>IN</sub> 250μA
	Clock Input High Voltage	3.3V	0.7 V <sub>CC</sub>	V <sub>CC</sub> +0.3	0.7 V <sub>CC</sub>	V <sub>CC</sub> +0.3	1.3	V	Driven by External Clock Generator
		5.0V	0.7 V <sub>CC</sub>	V <sub>CC</sub> +0.3	0.7 V <sub>CC</sub>	V <sub>CC</sub> +0.3	2.5	V	Driven by External Clock Generator
V <sub>CL</sub>	Clock Input Low Voltage	3.3V	GND -0.3 0.2 V <sub>CC</sub>		GND-0.3 0.2 V <sub>CC</sub>		0.7	V	Driven by External Clock Generator
		5.0V	GND-0.3 0.2 V <sub>CC</sub>		GND-0.3 0.2 V <sub>CC</sub>		1.5	V	Driven by External Clock Generator
V <sub>IH</sub>	Input High Voltage	3.3V	0.7 V <sub>CC</sub>	V <sub>CC</sub> +0.3	0.7 V <sub>CC</sub>	V <sub>CC</sub> +0.3	1.3	V	
		5.0V	0.7 V <sub>CC</sub>	V <sub>CC</sub> +0.3	0.7 V <sub>CC</sub>	V <sub>CC</sub> +0.3	2.5	V	
V <sub>IL</sub>	Input Low Voltage	3.3V	GND-0.3 0.2 V <sub>CC</sub>		GND-0.3 0.2 V <sub>CC</sub>		0.7	V	
		5.0V	GND-0.3 0.2 V <sub>CC</sub>		GND-0.3 0.2 V <sub>CC</sub>		1.5	V	
V <sub>OH</sub>	Output High Voltage	3.3V	V <sub>CC</sub> -0.4		V <sub>CC</sub> -0.4		3.1	V	I <sub>OH</sub> = -2.0 mA
		5.0V	V <sub>CC</sub> -0.4		V <sub>CC</sub> -0.4		4.8	V	I <sub>OH</sub> = -2.0 mA
V <sub>OL1</sub>	Output Low Voltage	3.3V		0.6		0.6	0.2	V	I <sub>OH</sub> = +4.0 mA
		5.0V		0.4		0.4	0.1	V	I <sub>OL</sub> = +4.0 mA
V <sub>OL2</sub>	Output Low Voltage	3.3V		1.2		1.2	0.3	V	I <sub>OL</sub> = +6 mA, 3 Pin Max
		5.0V		1.2		1.2	0.3	V	I <sub>OL</sub> = +12 mA, 3 Pin Max
V <sub>RH</sub>	Reset Input High Voltage	3.3V	.8 V <sub>CC</sub>	V <sub>CC</sub>	.8 V <sub>CC</sub>	V <sub>CC</sub>	1.5	V	
		5.0V	.8 V <sub>CC</sub>	V <sub>CC</sub>	.8 V <sub>CC</sub>	V <sub>CC</sub>	2.1	V	
V <sub>RI</sub>	Reset Input Low Voltage	3.3V	GND-0.3 0.2 V <sub>CC</sub>		GND-0.3 0.2 V <sub>CC</sub>		1.1		
		5.0V	GND-0.3 0.2 V <sub>CC</sub>		GND-0.3 0.2 V <sub>CC</sub>		1.7		
V <sub>OFFSET</sub>	Comparator Input Offset Voltage	3.3V		25		25	10	mV	
		5.0V		25		25	10	mV	
I <sub>IL</sub>	Input Leakage	3.3V	-1	1	-1	2	< 1	μA	V <sub>IN</sub> = 0V, V <sub>CC</sub>
		5.0V	-1	1	-1	2	< 1	μA	V <sub>IN</sub> = 0V, V <sub>CC</sub>
I <sub>OL</sub>	Output Leakage	3.3V	-1	1	-1	2	< 1	μA	V <sub>IN</sub> = 0V, V <sub>CC</sub>
		5.0V	-1	1	-1	2	< 1	μA	V <sub>IN</sub> = 0V, V <sub>CC</sub>
I <sub>IR</sub>	Reset Input Current	3.3V		-45		-60	-20	μA	
		5.0V		-55		-70	-30	μA	
I <sub>CC</sub> [4,5]	Supply Current	3.3V		10		10	4	mA	@ 8 MHz
		5.0V		15		15	10	mA	@ 8 MHz
		3.3V		15		15	5	mA	@ 12 MHz

[4,5]	5.0V	20	20	15	mA	@ 12 MHz
[4,5]						

Sym Notes	Parameter	V <sub>CC</sub> Note [3]	T <sub>A</sub> = 0°C to 70°C		T <sub>A</sub> = -40°C to 105°C		Typ @ 25°C	Units	Conditions
			Min	Max	Min	Max			
I <sub>CC1</sub> [4,5]	Standby Current	3.3V	3		3		1	mA	HALT Mode V <sub>IN</sub> = 0V, V <sub>CC</sub> @ 8 MHz
		5.0V	5		5		2.4	mA	HALT Mode
		3.3V	4		4		1.5	mA	HALT Mode
		5.0V	6		6		3.2	mA	HALT Mode
[4,5]		3.3V	2		2		0.8	mA	Clock Divide by 16 @ 8 MHz
		5.0V	4		4		1.8	mA	Clock Divide by 16 @ 8 MHz
		3.3V	3		3		1.2	mA	Clock Divide by 16 @ 8 MHz
		5.0V	5		5		2.5	mA	Clock Divide by 16 @ 12 MHz
I <sub>CC2</sub>	Standby Current	3.3V	8		15		1	μA	STOP Mode [6] V <sub>IN</sub> = 0V, V <sub>CC</sub> WDT is not Running
		5.0V	10		20		2	μA	STOP Mode [6] V <sub>IN</sub> = 0V, V <sub>CC</sub> WDT is not Running
		3.3V	500		600		310	μA	STOP Mode [6] V <sub>IN</sub> = 0V, V <sub>CC</sub> WDT is not Running
OV, V <sub>CC</sub>	Running Mode	5.0V 600	800 STOP	μA	=	=	=		
OV, V <sub>CC</sub>									

## AC CHARACTERISTICS

### External I/O or Memory Read and Write Timing Diagram

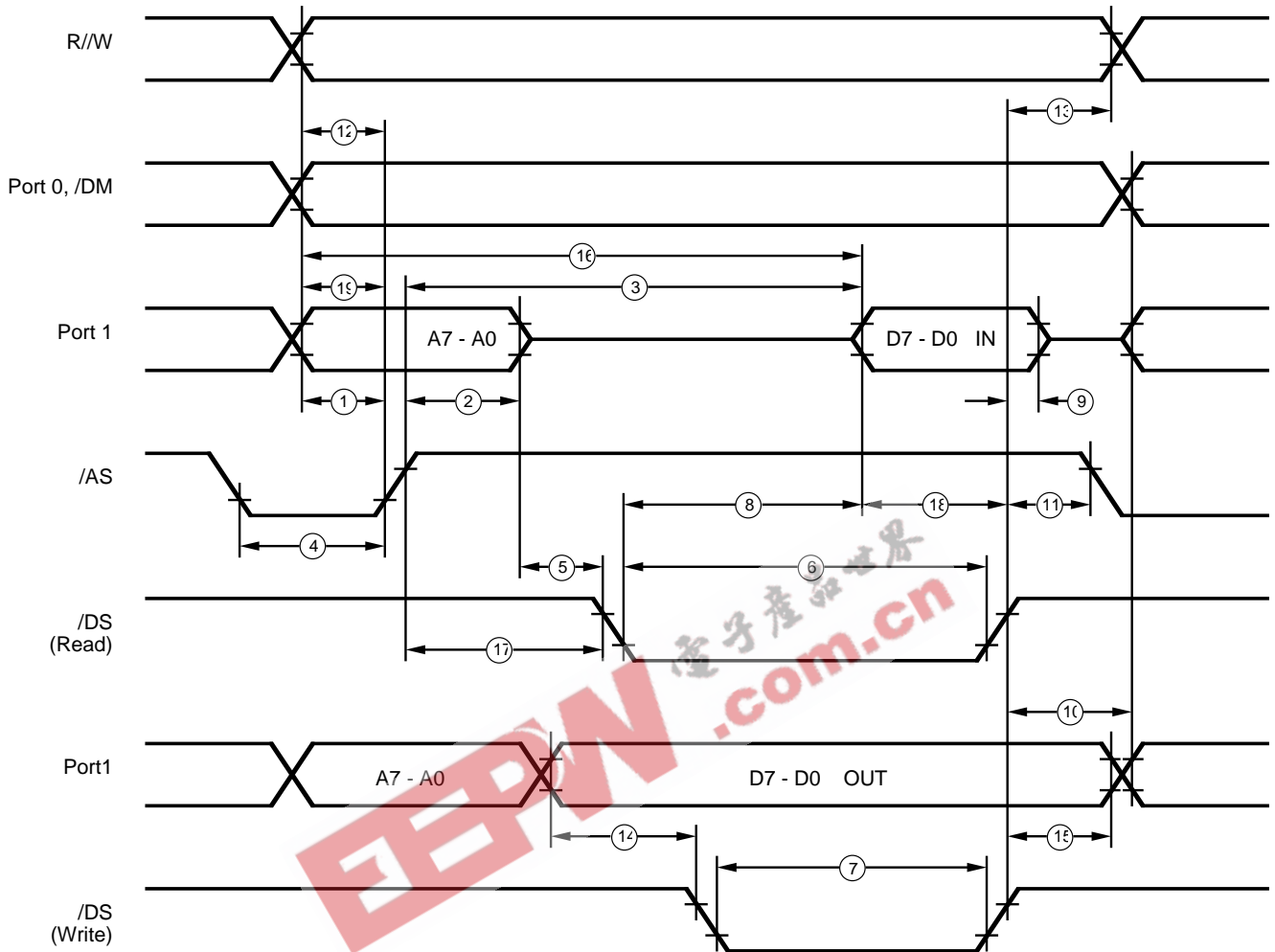

External I/O or Memory Read/Write Timing



## AC CHARACTERISTICS

External I/O or Memory Read and Write Timing Table

No	Symbol	Parameter	V <sub>cc</sub> Note[3]	T <sub>A</sub> = 0°C to +70°C				T <sub>A</sub> = -40°C to +105°C				Units	Notes
				8 MHz		12 MHz		8 MHz		12 MHz			
				Min	Max	Min	Max	Min	Max	Min	Max		
1	TdA(AS)	Address Valid to	3.3	55	35	55	35	ns	[2]				
		/AS Rising Delay	5.0	55	35	55	35	ns					
2	TdAS(A)	/AS Rising to Address	3.3	70	45	70	45	ns	[2]				
		Float Delay	5.0	70	45	70	45	ns					
3	TdAS(DR)	/AS Rising to Read	3.3	400	250	400	250	ns	[1,2]				
		Data Required Valid	5.0	400	250	400	250	ns					
4	TwAS	/AS Low Width	3.3	80	55	80	55	ns	[2]				
			5.0	80	55	80	55	ns					
5	Td	Address Float to	3.3	0	0	0	0	ns					
		/DS Falling	5.0	0	0	0	0	ns					
6	TwDSR	/DS (Read) Low Width	3.3	300	200	300	200	ns	[1,2]				
			5.0	300	200	300	200	ns					
7	TwDSW	/DS (Write) Low Width	3.3	165	110	165	110	ns	[1,2]				
			5.0	165	110	165	110	ns					
8	TdDSR(DR)	/DS Falling to Read	3.3	260	150	260	150	ns	[1,2]				
		Data Required Valid	5.0	260	160	260	160	ns					
9	ThDR(DS)	Read Data to	3.3	0	0	0	0	ns	[2]				
		/DS Rising Hold Time	5.0	0	0	0	0	ns					
10	TdDS(A)	/DS Rising to Address	3.3	85	45	85	45	ns	[2]				
		Active Delay	5.0	95	55	95	55	ns					
11	TdDS(AS)	/DS Rising to /AS	3.3	60	30	60	30	ns	[2]				
		Falling Delay	5.0	70	45	70	45	ns					
12	TdR/W(AS)	R/W Valid to /AS	3.3	70	45	70	45	ns	[2]				
		Rising Delay	5.0	70	45	70	45	ns					
13	TdDS(R/W)	/DS Rising to	3.3	70	45	70	45	ns	[2]				
		R/W Not Valid	5.0	70	45	70	45	ns					
14	TdDW(DSW)	Write Data Valid to /DS	3.3	80	55	80	55	ns	[2]				
		Falling (Write) Delay	5.0	80	55	80	55	ns					
15	TdDS(DW)	/DS Rising to Write	3.3	70	45	70	45	ns	[2]				
		Data Not Valid Delay	5.0	80	55	80	55	ns					
16	TdA(DR)	Address Valid to Read	3.3	475	310	475	310	ns	[1,2]				
		Data Required Valid	5.0	475	310	475	310	ns					
17	TdAS(DS)	/AS Rising to	3.3	100	65	100	65	ns	[2]				
		/DS Falling Delay	5.0	100	65	100	65	ns					
18	TdDI(DS)	Data Input Setup to	0.0	115	115	115	115	ns	[1,2]				
		/DS Rising	5.0	75	75	75	75	ns					
19	TdDM(AS)	/DM Valid to /AS	3.3	55	35	55	35	ns	[2]				
		Falling Delay	5.0	55	35	55	35	ns					

### Notes:

[1] When using extended memory timing add 2 TpC.

[2] Timing numbers given are for minimum TpC.

[3] 5.0V ±0.5V, 3.3V ±0.3V.

### Standard Test Load

All timing references use 0.9 V<sub>cc</sub> for a logic 1 and 0.1 V<sub>cc</sub> for a logic 0.

# AC CHARACTERISTICS

## Additional Timing Diagram

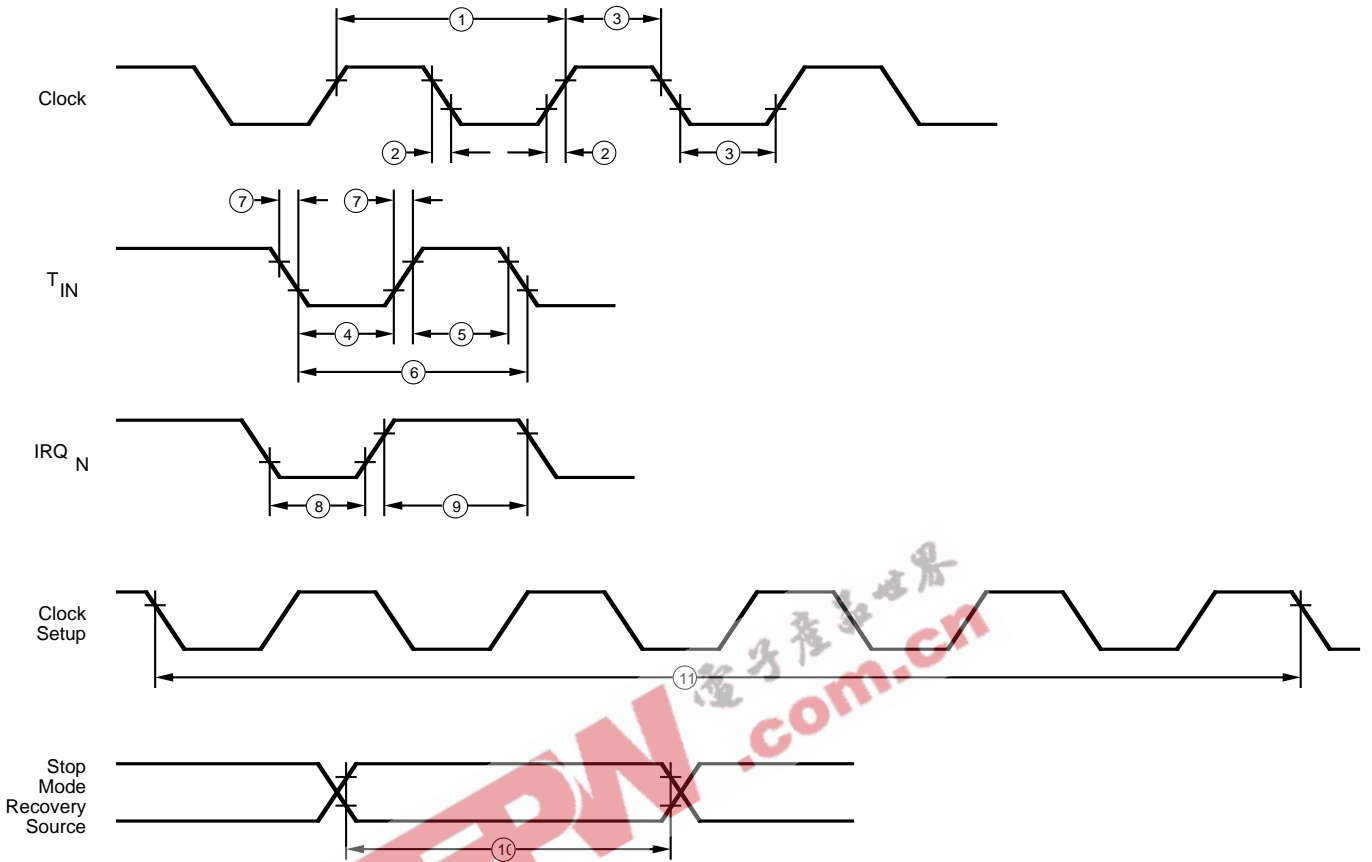

Additional Timing

## AC CHARACTERISTICS

### Additional Timing Table

No	Symbol	Parameter	V <sub>CC</sub>	T <sub>A</sub> = 0°C to 70°C				T <sub>A</sub> = -40°C to 105°C				Units	
				Note[6]	8 MHz		12 MHz		8 MHz		12 MHz		
Notes				Min	Max	Min	Max	Min	Max	Min	Max		
1	TpC	Input Clock Period	3.3V	125	100000	83	100000	125	100000	83	100000	ns	[1]
			5.0V	125	100000	83	100000	125	100000	83	100000	ns	[1]
2	TrC,TfC	Clock Input Rise and Fall Times	3.3V	25		15		25		15		ns	[1]
			5.0V	25		15		25		15		ns	[1]
3	TwC	Input Clock Width	3.3V	37		26		37		26		ns	[1]
			5.0V	37		26		37		26		ns	[1]
4	TwTinL	Timer Input Low Width	3.3V	100		100		100		100		ns	[1]
			5.0V	70		70		70		70		ns	[1]
5	TwTinH	Timer Input High Width	3.3V	3TpC		3TpC		3TpC		3TpC			[1]
			5.0V	3TpC		3TpC		3TpC		3TpC			[1]
6	TpTin	Timer Input Period	3.3V	8TpC		8TpC		8TpC		8TpC			[1]
			5.0V	8TpC		8TpC		8TpC		8TpC			[1]
7	TrTin,TfTin	Timer Input Rise and Fall Timers	3.3V	100		100		100		100		ns	[1]
			5.0V	100		100		100		100		ns	[1]
8A	TwIL	Interrupt Request Low Time	3.3V	100		100		100		100		ns	[1,2]
			5.0V	70		70		70		70		ns	[1,2]
8B	TwIL	Int. Request Low Time	3.3V	3TpC		3TpC		3TpC		3TpC			[1,3]
			5.0V	3TpC		3TpC		3TpC		3TpC			[1,3]
9	TwIH	Interrupt Request Input High Time	3.3V	3TpC		3TpC		3TpC		3TpC			[1,2]
			5.0V	3TpC		3TpC		3TpC		3TpC			[1,2]
10	Twsm	STOP Mode Recovery Width Spec	3.3V	12		12		12		12		ns	
			5.0V	12		12		12		12			ns
			3.3V	5TpC									[7]
			5.0V	5TpC								[8]	

## AC CHARACTERISTICS

### Additional Timing Table (Continued)

No	Symbol	Parameter	V <sub>cc</sub> Note[6]	T <sub>A</sub> = 0°C to 70°C				T <sub>A</sub> = -40°C to 105°C				Units	Notes
				8 MHz		12 MHz		8 MHz		12 MHz			
				Min	Max	Min	Max	Min	Max	Min	Max		
11	Tost	Oscillator Startup Time	3.3V 5.0V	5TpC 5TpC		5TpC 5TpC		5TpC 5TpC		5TpC 5TpC			[4] [4]
12	Twdt	Watchdog Timer	3.3V	10		10		10		10		ms	D0 = 0
[5]		Delay Time	5.0V	5		5		5		5		ms	D1 = 0
[5]			3.3V	30		30		30		30		ms	D0 = 1
[5]			5.0V	15		15		15		15		ms	D1 = 0
[5]			3.3V	50		50		50		50		ms	D0 = 0
[5]			5.0V	25		25		25		25		ms	D1 = 1
[5]			3.3V	200		200		200		200		ms	D0 = 1
[5]			5.0V	100		100		100		100		ms	D1 = 1

#### Notes:

- [1] Timing Reference uses 0.9 V<sub>cc</sub> for a logic 1 and 0.1 V<sub>cc</sub> for a logic 0.
- [2] Interrupt request via Port 3 (P31-P33).
- [3] Interrupt request via Port 3 (P30).
- [4] SMR-D5 = 0
- [5] Reg. WDTMR
- [6] 5.0V ±0.5V, 3.3V ±0.3V
- [7] Reg. SMR - D5=0
- [8] Reg. SMR - D5=1

## AC CHARACTERISTICS

### Handshake Timing Diagrams

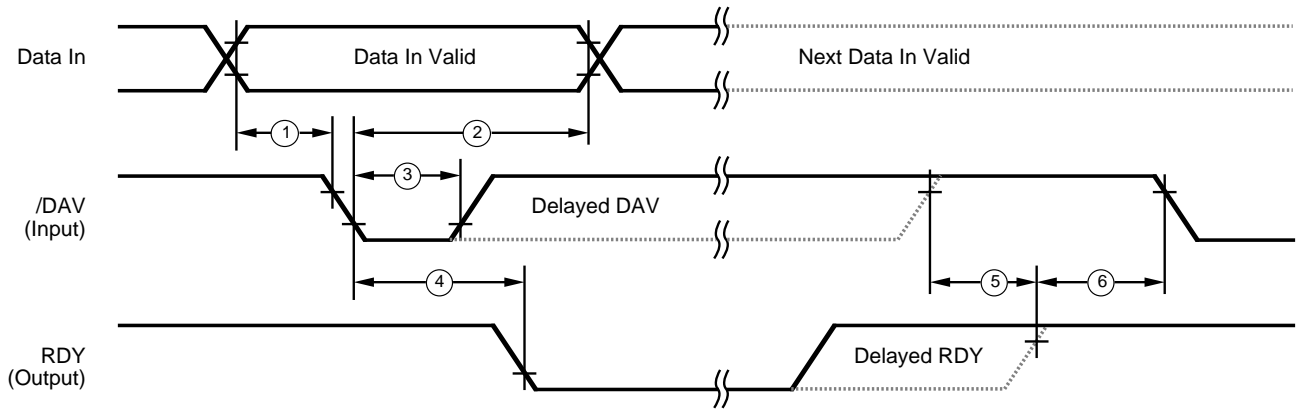

Input Handshake Timing

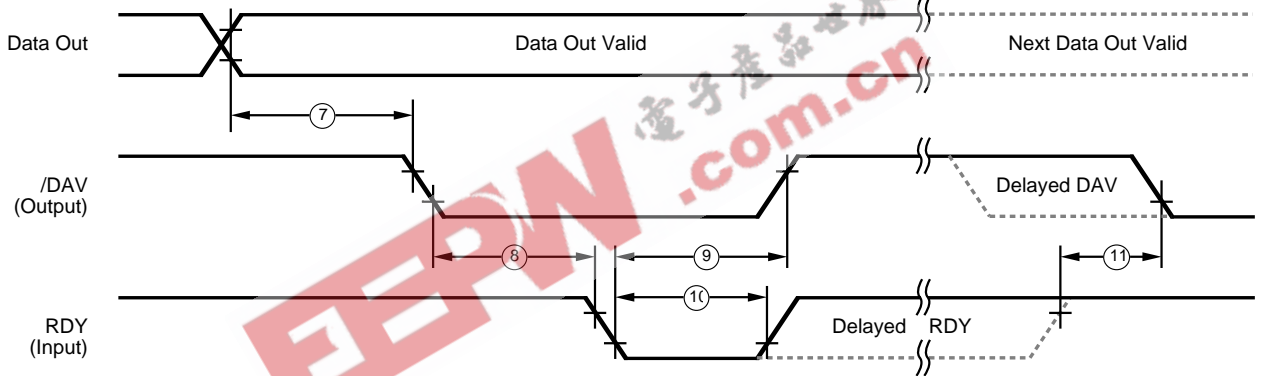

Output Handshake Timing

## AC CHARACTERISTICS

### Handshake Timing Table

No	Symbol	Parameter	V <sub>CC</sub> Note[1]	T <sub>A</sub> = 0°C To 70° C				T <sub>A</sub> = -40° C To 105° C				Data Direc- tion
				8 MHz		12 MHz		8 MHz		12 MHz		
				Min	Max	Min	Max	Min	Max	Min	Max	
1	TsDI(DAV)	Data In Setup Time	3.3V	0		0		0		0		IN
			5.0V	0		0		0		0		IN
2	ThDI(DAV)	Data In Hold Time	3.3V	160		160		160		160		IN
			5.0V	115		115		115		115		IN
3	TwDAV	Data Available Width	3.3V	155		155		155		155		IN
			5.0V	110		110		110		110		IN
4	TdDAVI(RDY)	DAV Falling to RDY Falling Delay	3.3V		160		160		160		160	IN
			5.0V		115		115		115		115	IN
5	TdDAVIId(RDY)	DAV Rising to RDY Falling Delay	3.3V		120		120		120		120	IN
			5.0V		80		80		80		80	IN
6	TdDO(DAV)	RDY Rising to DAV Falling Delay	3.3V	0		0		0		0		IN
			5.0V	0		0		0		0		IN
7	TcLDAV0(RDY)	Data Out to DAV Falling Delay	3.3V	63		42		63		42		OUT
			5.0V	63		42		63		42		OUT
8	TcLDAV0(RDY)	DAV Falling to RDY Falling Delay	3.3V	0		0		0		0		OUT
			5.0V	0		0		0		0		OUT
9	TdRDY0(DAV)	RDY Falling to DAV Rising Delay	3.3V		160		160		160		160	OUT
			5.0V		115		115		115		115	OUT
10	TwRDY	RDY Width	3.3V	110		110		110		110		OUT
			5.0V	80		80		80		80		OUT
11	TdRDY0d(DAV)	RDY Rising to DAV Falling Delay	3.3V		110		110		110		110	OUT
			5.0V		80		80		80		80	OUT

**Note:**

[1] 5.0 V ±0.5V, 3.3V ±0.3V

© 1991 by Zilog, Inc. All rights reserved. No part of this document may be copied or reproduced in any form or by any means without the prior written consent of Zilog, Inc. The information in this document is subject to change without notice. Devices sold by Zilog, Inc. are covered by warranty and patent indemnification provisions appearing in Zilog, Inc. Terms and Conditions of Sale only. Zilog, Inc. makes no warranty, express, statutory, implied or by description, regarding the information set forth herein or regarding the freedom of the described devices from intellectual property infringement. Zilog, Inc. makes no warranty of merchantability or fitness for any purpose. Zilog, Inc. shall not be

responsible for any errors that may appear in this document. Zilog, Inc. makes no commitment to update or keep current the information contained in this document.

Zilog, Inc. 210 East Hacienda Ave.  
Campbell, CA 95008-6600  
Telephone (408) 370-8000  
Telex 171-980 A/B ZILOG CPTO  
FAX 408 370-8056/8027