



256K × 8 CMOS FLASH MEMORY WITH FWH INTERFACE

GENERAL DESCRIPTION

The W49V002FA is a 2-megabit, 3.3-volt only CMOS flash memory organized as 256K × 8 bits. The device can be programmed and erased in-system with a standard 3.3V power supply. A 12-volt VPP is not required. The unique cell architecture of the W49V002FA results in fast program/erase operations with extremely low current consumption. This device can operate at two modes, Programmer bus interface mode and FWH bus interface mode. As in the Programmer interface mode, it acts like the traditional flash but with a multiplexed address inputs. But in the FWH interface mode, this device complies with the Intel FWH specification. The device can also be programmed and erased using standard EPROM programmers.

FEATURES

- Single 3.3-volt operations:
 - 3.3-volt Read
 - 3.3-volt Erase
 - 3.3-volt Program
- Fast program operation:
 - Byte-by-byte programming: 50 μS (typ.)
- Fast erase operation: 150 mS (typ.)
- Fast read access time: Tkq 11 nS
- Endurance: 10K cycles (typ.)
- Twenty-year data retention
- Hardware data protection
 - #TBL & #WP serve as hardware protection
- One 16K bytes Boot Block with lockout protection
- Two 8K bytes Parameter Blocks
- Four main memory blocks (with 32K bytes, 64K bytes, 64K bytes, 64K bytes each)
- Low power consumption
 - Active current: 40 mA (typ. for FWH)
- Automatic program and erase timing with internal VPP generation
- End of program or erase detection
 - Toggle bit
 - Data polling
- Latched address and data
- TTL compatible I/O
- Available packages: 32L PLCC, 32L STSOP



PIN CONFIGURATIONS

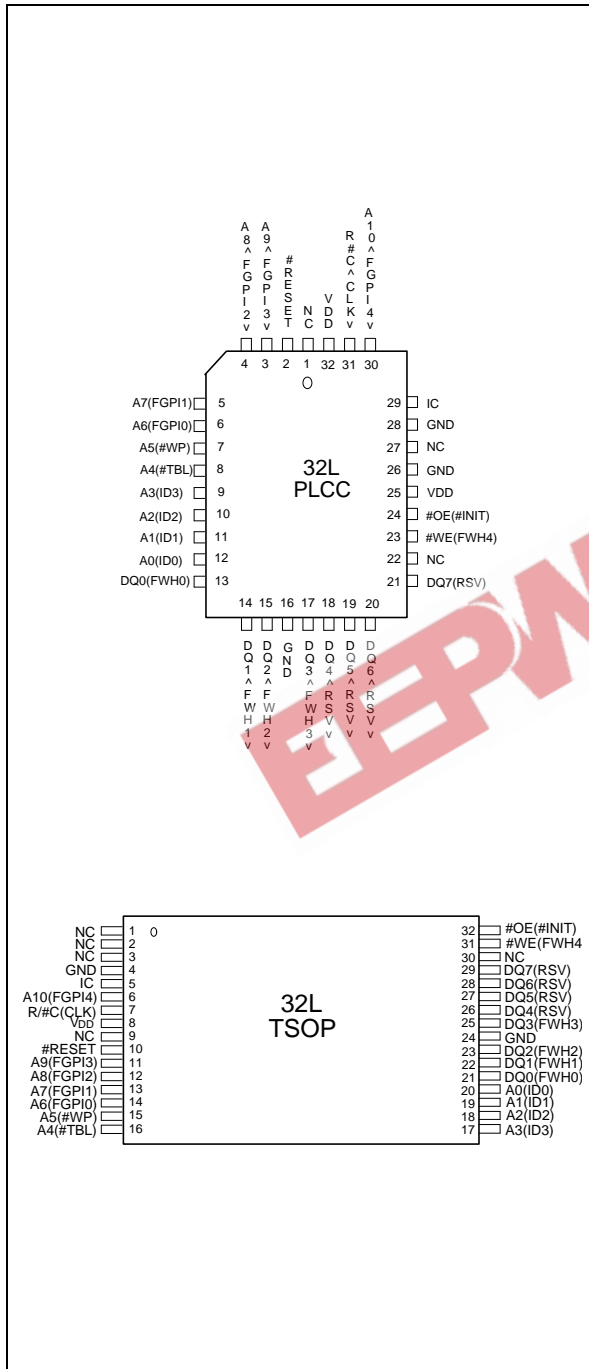

BLOCK DIAGRAM

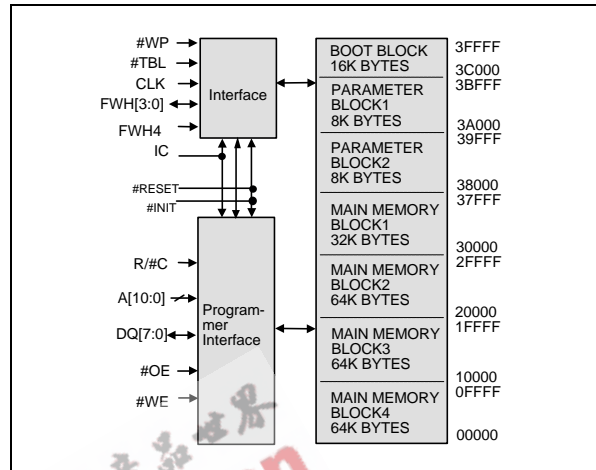

PIN DESCRIPTION

SYM.	INTERFACE		PIN NAME
	PGM	FWH	
IC	*	*	Interface Mode Selection
#RESET	*	*	Reset
#INIT		*	Initialize
#TBL		*	Top Boot Block Lock
#WP		*	Write Protect
CLK		*	CLK Input
FGPI[4:0]		*	General Purpose Inputs
ID[3:0]		*	Identification Inputs They Are Internal Pull Down to Vss
FWH[3:0]		*	Address/Data Inputs
FWH4		*	FWH Cycle Initial
R/#C	*		Row/Column Select
A[10:0]	*		Address Inputs
DQ[7:0]	*		Data Inputs/Outputs
#OE	*		Output Enable
#WE	*		Write Enable
VDD	*	*	Power Supply
GND	*	*	Ground
RSV	*	*	Reserved Pins
NC	*	*	No Connection



FUNCTIONAL DESCRIPTION

Interface Mode Selection And Description

This device can be operated in two interface modes, one is Programmer interface mode, the other is FWH interface mode. The IC pin of the device provides the control between these two interface modes. These interface modes need to be configured before power up or return from #RESET. When IC pin is set to high state, the device will be in the Programmer mode; while the IC pin is set to low state (or leaved no connection), it will be in the FWH mode. In Programmer mode, this device just behaves like traditional flash parts with 8 data lines. But the row and column address inputs are multiplexed, which go through address inputs A[10:0]. For FWH mode, It complies with the FWH Interface Specification. Through the FWH[3:0] to communicate with the system chipset .

Read (Write) Mode

In Programmer interface mode, the read (write) operation of the W49V002FA is controlled by #OE (#WE). The #OE(#WE) is held low for the host to obtain(write) data from(to) the outputs(inputs). #OE is the output control and is used to gate data from the output pins. The data bus is in high impedance state when #OE is high. As for in the FWH interface mode, the read or write is determined by the "bit 0 & bit 1 of START CYCLE ". Refer to the FWH cycle definition for further details.

Reset Operation

The #RESET input pin can be used in some application. When #RESET pin is at high state, the device is in normal operation mode. When #RESET pin is at low state, it will halt the device and all outputs will be at high impedance state. As the high state re-asserted to the #RESET pin, the device will return to read or standby mode, it depends on the control signals.

Chip Erase Operation

The chip-erase mode can be initiated by a six-byte command sequence. After the command loading cycle, the device enters the internal chip erase mode, which is automatically timed and will be completed within fast 150 mS (typical). The host system is not required to provide any control or timing during this operation. If the boot block programming lockout is activated, only the data in the other memory blocks will be erased to FF(hex) while the data in the boot block will not be erased (remains as the same state before the chip erase operation). The entire memory array will be erased to FF(hex) by the chip erase operation if the boot block programming lockout feature is not activated. The device will automatically return to normal read mode after the erase operation completed. Data polling and/or Toggle Bits can be used to detect end of erase cycle.

Sector Erase Operation

The seven sectors, one boot block and two parameter memory and four main blocks, can be erased individually by initiating a six-byte command sequence. Sector address is latched on the falling #WE edge of the sixth cycle, while the 30(hex) data input command is latched at the rising edge of #WE. After the command loading cycle, the device enters the internal sector erase mode, which is automatically timed and will be completed within fast 150 mS (typical). The host system is not required to provide any control or timing during this operation. The device will automatically return to normal read mode after the erase operation completed. Data polling and/or Toggle Bits can be used to detect end of erase cycle.



Program Operation

The W49V002FA is programmed on a byte-by-byte basis. Program operation can only change logical data "1" to logical data "0." The erase operation, which changed entire data in main memory and/or boot block from "0" to "1", is needed before programming.

The program operation is initiated by a 4-byte command cycle (see Command Codes for Byte Programming). The device will internally enter the program operation immediately after the byte-program command is entered. The internal program timer will automatically time-out (100 μ S max. - TBP) once it is completed and then return to normal read mode. Data polling and/or Toggle Bits can be used to detect end of program cycle.

Boot Block Operation and Hardware Protection at Initial- #TBL & #WP

There are two alternatives to set the boot block. One is software command sequences method; the other is hardware method. 16K-byte in the top location of this device can be locked as boot block, which can be used to store boot codes. It is located in the last 16K bytes of the memory with the address range from 3C000(hex) to 3FFFF(hex).

Please see Command Codes for Boot Block Lockout Enable for the specific code. Once this feature is set, the data for the designated block cannot be erased or programmed (programming lockout), other memory locations can be changed by the regular programming method.

Besides the software method, there is a hardware method to protect the top boot block and other sectors. Before program/erase to this device, set the #TBL pin to low state and then the top boot block will not be programmed/erased. When enabling hardware top boot block, #TBL being low state, it will override the software method setting. That is, if #TBL is at low state, then top boot block cannot be programmed/erased no matter how the software boot block lock setting.

Another pin, #WP, will protect the whole chip if this pin is set to low state before program/erase. The enable of this pin will override the #TBL setting. That is, the top boot block cannot be programmed/erased if this pin is set to low no matter how the #TBL or software boot block lock setting.

Hardware Data Protection

The integrity of the data stored in the W49V002FA is also hardware protected in the following ways:

- (1) Noise/Glitch Protection: A #WE pulse of less than 15 nS in duration will not initiate a write cycle.
- (2) VDD Power Up/Down Detection: The programming and read operation are inhibited when VDD is less than 1.5V typical.
- (3) Write Inhibit Mode: Forcing #OE low or #WE high will inhibit the write operation. This prevents inadvertent writes during power-up or power-down periods.
- (4) VDD power-on delay: When VDD has reached its sense level, the device will automatically time-out 5 mS before any write (erase/program) operation.

Data Polling (DQ7)- Write Status Detection

The W49V002FA includes a data polling feature to indicate the end of a program or erase cycle. When the W49V002FA is in the internal program or erase cycle, any attempts to read DQ7 of the last byte loaded will receive the complement of the true data. Once the program or erase cycle is completed, DQ7 will show the true data. Note that DQ7 will show logical "0" during the erase cycle, and when erase cycle has been completed it becomes logical "1" or true data.



Toggle Bit (DQ6)- Write Status Detection

In addition to data polling, the W49V002FA provides another method for determining the end of a program cycle. During the internal program or erase cycle, any consecutive attempts to read DQ6 will produce alternating 0's and 1's. When the program or erase cycle is completed, this toggling between 0's and 1's will stop. The device is then ready for the next operation.

General Purpose Inputs Register

This register reads the FGPI[4:0] pins on the W49V002FA. This is a pass-through register which can read via memory address FFBC0100(hex). Since it is pass-through register, there is no default value.

BIT	FUNCTION
7 – 5	Reserved
4	Read FGPI4 pin status
3	Read FGPI3 pin status
2	Read FGPI2 pin status
1	Read FGPI1 pin status
0	Read FGPI0 pin status

Product Identification

The product ID operation outputs the manufacturer code and device code. Programming equipment automatically matches the device with its proper erase and programming algorithms.

The manufacturer and device codes can be accessed by software operation. In the software access mode, a six-byte (or JEDEC 3-byte) command sequence can be used to access the product ID for programmer interface mode. A read from address 0000(hex) outputs the manufacturer code, DA(hex). A read from address 0001(hex) outputs the device code, 32(hex).” The product ID operation can be terminated by a three-byte command sequence or an alternate one-byte command sequence (see Command Definition table).

As for FWH interface mode, a read from FFBC, 0000(hex) can output the manufacturer code, DA(hex). A read from FFBC, 0001(hex) can output the device code 32(hex).

TABLE OF OPERATING MODES

Operating Mode Selection - Programmer Mode

(V_{HH} = 12V ± 5%)

MODE	PINS				
	#OE	#WE	#RESET	ADDRESS	DQ.
Read	VIL	VIH	VIH	AIN	Dout
Write	VIH	VIL	VIH	AIN	Din
Standby	X	X	VIL	X	High Z
Write Inhibit	VIL	X	VIH	X	High Z/DOUT
	X	VIH	VIH	X	High Z/DOUT
Output Disable	VIH	X	VIH	X	High Z



Operating Mode Selection - FWH Mode

Operation modes in FWH interface mode are determined by "START Cycle" when it is selected. When it is not selected, its outputs (FWH[3:0]) will be disable. Please reference to the "FWH Cycle Definition".

TABLE OF COMMAND DEFINITION

COMMAND DESCRIPTION	NO. OF Cycles	1ST CYCLE	2ND CYCLE	3RD CYCLE	4TH CYCLE	5TH CYCLE	6TH CYCLE
		Addr. Data	Addr. Data	Addr. Data	Addr. Data	Addr. Data	Addr. Data
Read	1	A _{IN} D _{OUT}					
Chip Erase	6	5555 AA	2AAA 55	5555 80	5555 AA	2AAA 55	5555 10
Sector Erase	6	5555 AA	2AAA 55	5555 80	5555 AA	2AAA 55	SA 30
Byte Program	4	5555 AA	2AAA 55	5555 A0	A _{IN} D _{IN}		
Boot Block Lockout	6	5555 AA	2AAA 55	5555 80	5555 AA	2AAA 55	5555 40
Product ID Entry	3	5555 AA	2AAA 55	5555 90			
Product ID Exit ⁽¹⁾	3	5555 AA	2AAA 55	5555 F0			
Product ID Exit ⁽¹⁾	1	XXXX F0					

Notes:

1. The cycle means the write command cycle not the FWH clock cycle.
2. The Column Address / Row Address are mapped to the Low / High order Internal Address. i.e. Column Address A[10:0] are mapped to the internal A[10:0], Row Address A[6:0] are mapped to the internal A[17:11]
3. Address Format: A14-A0 (Hex); Data Format: DQ7-DQ0 (Hex)
4. Either one of the two Product ID Exit commands can be used.
5. SA: Sector Address
 SA = 3C000h to 3FFFFh for Boot Block
 SA = 3A000h to 3BFFFh for Parameter Block1
 SA = 38000h to 39FFFh for Parameter Block2
 SA = 30000h to 37FFFh for Main Memory Block1
 SA = 2XXXXh for Main Memory Block2
 SA = 1XXXXh for Main Memory Block3
 SA = 0XXXXh for Main Memory Block4



FWH CYCLE DEFINITION

FIELD	NO. OF CLOCKS	DESCRIPTION
START	1	"1101b" indicates FWH Memory Read cycle; while "1110b" indicates FWH Memory Write cycle.
IDSEL	1	This one clock field indicates which FWH component is being selected.
MSIZE	1	Memory Size. There is always show "0000b" for single byte access.
TAR	2	Turned Around Time
ADDR	7	Address Phase for Memory Cycle. FWH supports the 28 bits address protocol. The addresses transfer most significant nibble first and least significant nibble last. (i.e. Address[27:24] on FWH[3:0] first , and Address[3:0] on FWH[3:0] last.)
SYNC	N	Synchronous to add wait state. "0000b" means Ready, "0101b" means Short Wait, "0110b" means Long Wait, "1001b" for DMA only, "1010b" means error, and other values are reserved.
DATA	2	Data Phase for Memory Cycle. The data transfer least significant nibble first and most significant nibble last. (i.e. DQ[3:0] on FWH[3:0] first , then DQ[7:4] on FWH[3:0] last.)



Embedded Programming Algorithm

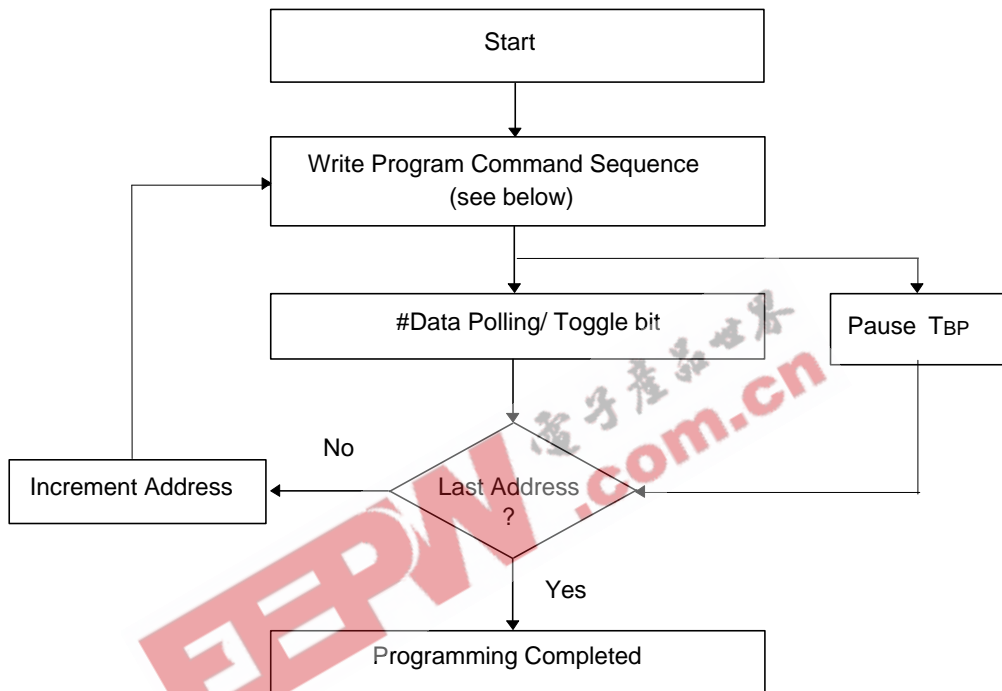

Program Command Sequence (Address/Command):

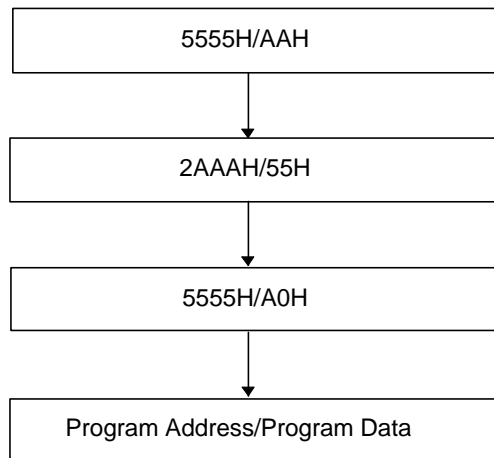



Embedded Erase Algorithm

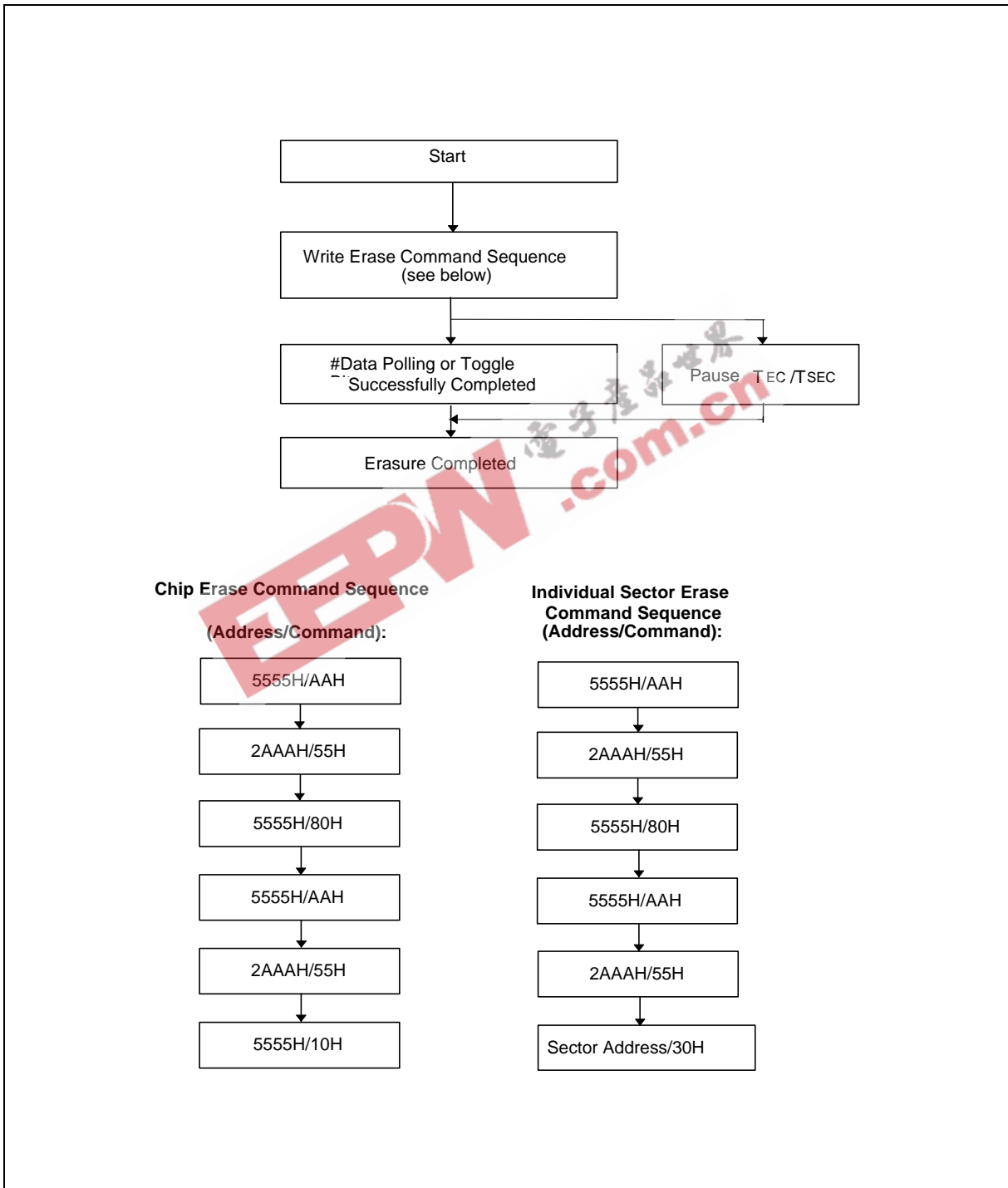



Embedded #Data Polling Algorithm

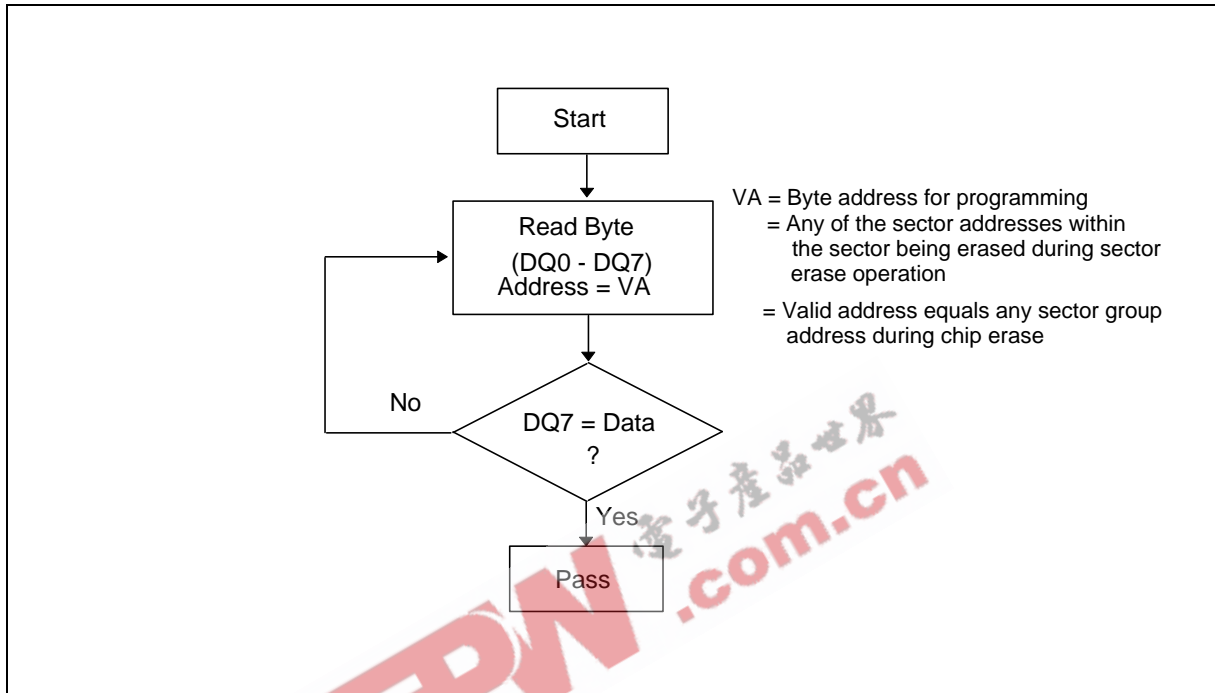

Embedded Toggle Bit Algorithm

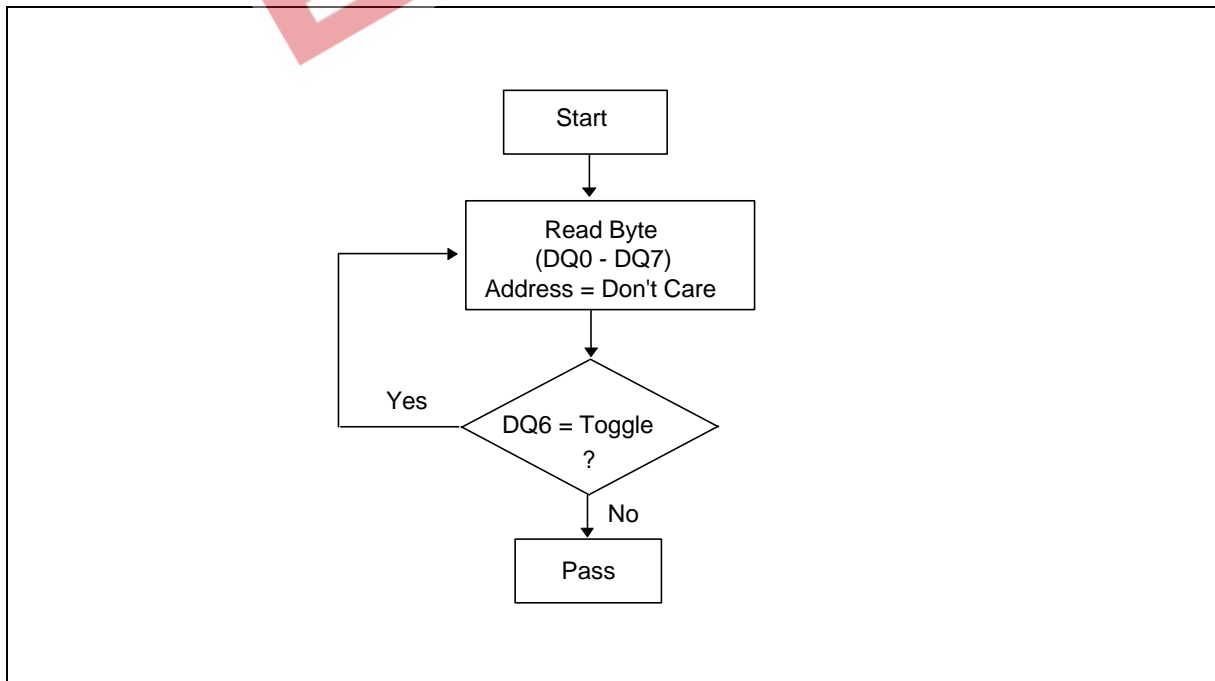



Software Product Identification and Boot Block Lockout Detection Acquisition Flow

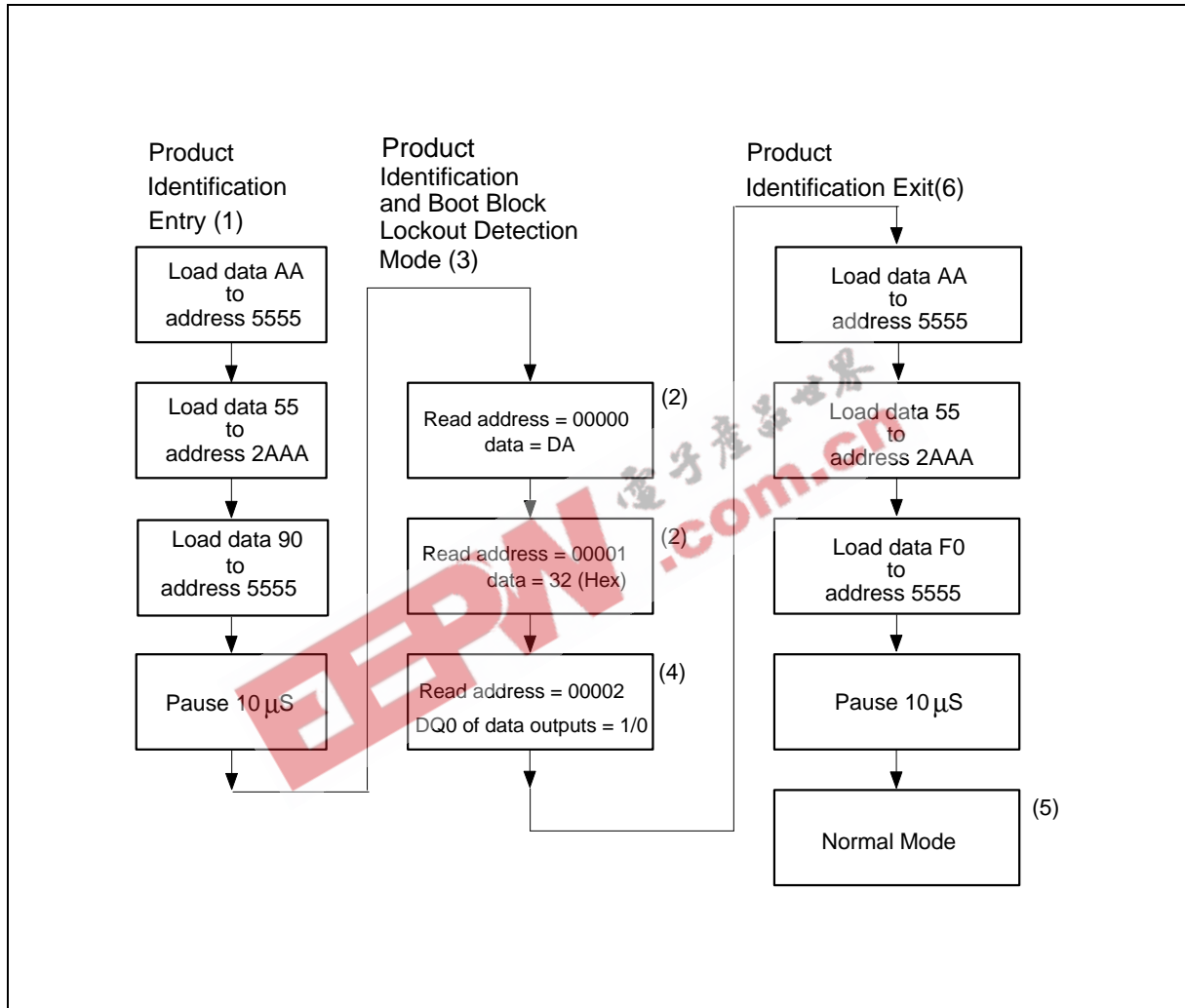

Notes for software product identification/boot block lockout detection:

- (1) Data Format: DQ7 – DQ0 (Hex); Address Format: A14 – A0 (Hex)
- (2) A1 – A17 = V_{IL}; manufacture code is read for A0 = V_{IL}; device code is read for A0 = V_{IH}.
- (3) The device does not remain in identification and boot block lockout detection mode if power down.
- (4) If the DQ0 of output data is "1," the boot block programming lockout feature is activated; if the DQ0 of output data "0," the lockout feature is inactivated and the block can be programmed.
- (5) The device returns to standard operation mode.
- (6) Optional 1-write cycle (write F0 hex at XXXX address) can be used to exit the product identification/boot block lockout detection.

Boot Block Lockout Enable Acquisition Flow

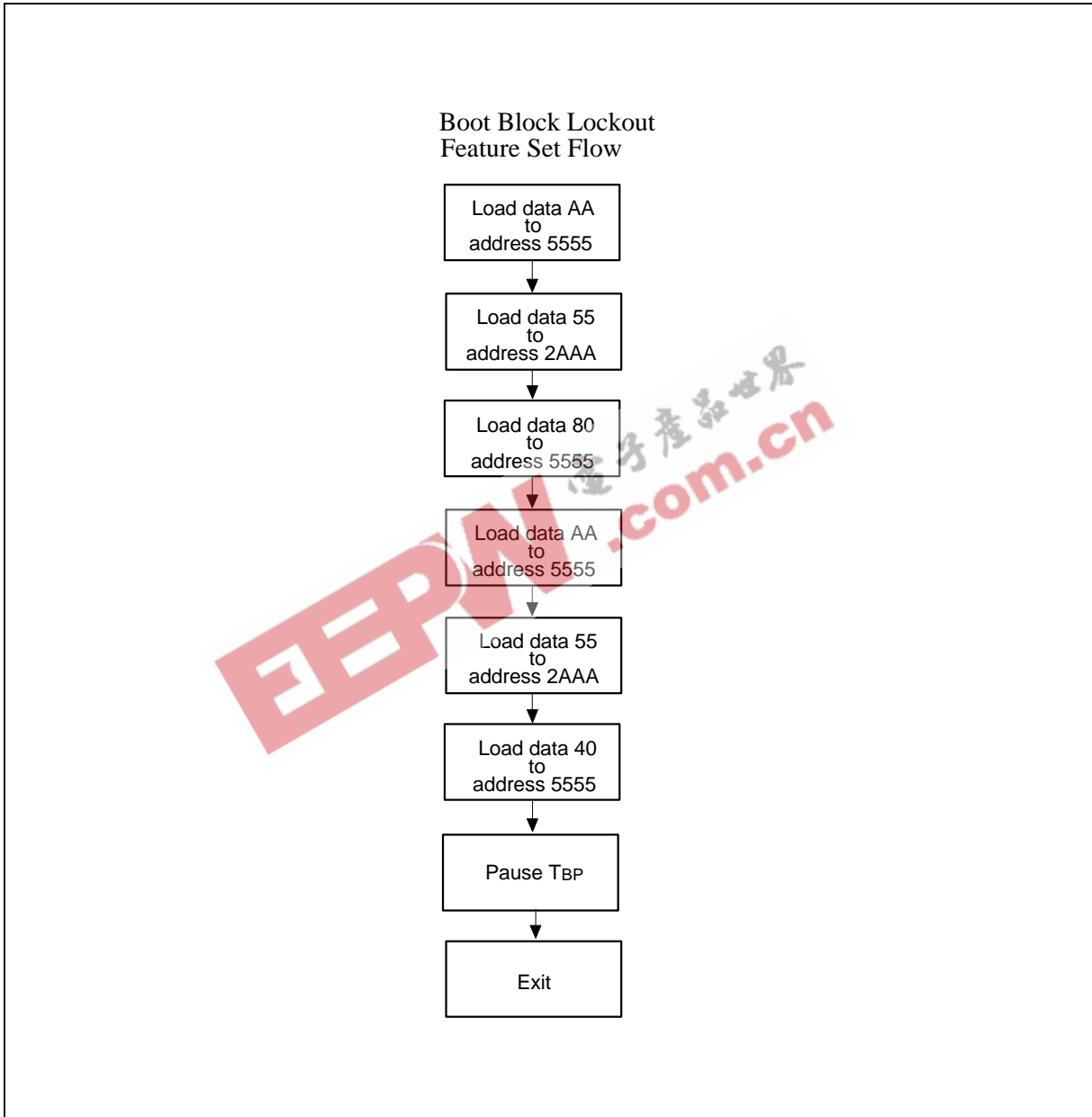



DC CHARACTERISTICS

Absolute Maximum Ratings

PARAMETER	RATING	UNIT
Power Supply Voltage to Vss Potential	-0.5 to +4.1	V
Operating Temperature	0 to +70	°C
Storage Temperature	-65 to +150	°C
D.C. Voltage on Any Pin to Ground Potential	-0.5 to VDD +0.5	V
Transient Voltage (<20 nS) on Any Pin to Ground Potential	-1.0 to VDD +0.5	V

Note: Exposure to conditions beyond those listed under Absolute Maximum Ratings may adversely affect the life and reliability of the device.

Programmer interface Mode DC Operating Characteristics

(VDD = 3.3V ± 5%, VGND= 0V, TA = 0 to 70° C)

PARAMETER	SYM.	TEST CONDITIONS	LIMITS			UNIT
			MIN.	TYP.	MAX.	
Power Supply Current	ICC	In Read or Write mode, all DQs open Address inputs = 3.0V/0V, at f = 3 MHz	-	20	30	mA
Input Leakage Current	ILI	VIN = GND to VDD	-	-	10	μA
Output Leakage Current	ILO	VOUT = GND to VDD	-	-	10	μA
Input Low Voltage	VIL	-	-0.3	-	0.8	V
Input High Voltage	VIH	-	2.0	-	VDD +0.5	V
Output Low Voltage	VOL	IOL = 2.1 mA	-	-	0.45	V
Output High Voltage	VOH	IOH = -0.1mA	2.4	-	-	V



FWH interface Mode DC Operating Characteristics

($V_{DD} = 3.3V \pm 5\%$, $V_{GND} = 0V$, $T_A = 0$ to $70^\circ C$)

PARAMETER	SYM.	TEST CONDITIONS	LIMITS			UNIT
			MIN.	TYP.	MAX.	
Power Supply Current	ICC	All Iout = 0A, CLK = 33 MHz, in FWH mode operation.	-	40	60	mA
Standby Current	ISB1	FWH4 = 0.9 VDD, CLK = 33 MHz, all inputs = 0.9 VDD/ 0.1 VDD, no internal operation	-	20	100	μA
Standby Current	ISB2	FWH4 = 0.1 VDD, CLK = 33 MHz, all inputs = 0.9 VDD/ 0.1 VDD, no internal operation	-	3	10	mA
Input Low Voltage	VIL	-	-0.5	-	0.3 VDD	V
Input High Voltage	VIH	-	0.5 VDD	-	VDD +0.5	V
Input Low Voltage for #INIT	VILI	-	-0.5V	-	0.2 VDD	V
Input High Voltage for #INIT	VIHI	-	1.35V	-	VDD +0.5	V
Output Low Voltage	VOL	IOL = 1.5 mA	-	-	0.1 VDD	V
Output High Voltage	VOH	IOH = -0.5 mA	0.9 VDD	-	-	V

Power-up Timing

PARAMETER	SYMBOL	TYPICAL	UNIT
Power-up to Read Operation	TPU. READ	100	μS
Power-up to Write Operation	TPU. WRITE	5	mS

CAPACITANCE

($V_{DD} = 3.3V$, $T_A = 25^\circ C$, $f = 1$ MHz)

PARAMETER	SYMBOL	CONDITIONS	MAX.	UNIT
I/O Pin Capacitance	C _{I/O}	V _{I/O} = 0V	12	pF
Input Capacitance	C _{IN}	V _{IN} = 0V	6	pF



PROGRAMMER INTERFACE MODE AC CHARACTERISTICS

AC Test Conditions

PARAMETER	CONDITIONS
Input Pulse Levels	0V to 0.9 VDD
Input Rise/Fall Time	< 5 nS
Input/Output Timing Level	1.5V/1.5V
Output Load	1 TTL Gate and CL = 30 pF

AC Test Load and Waveform

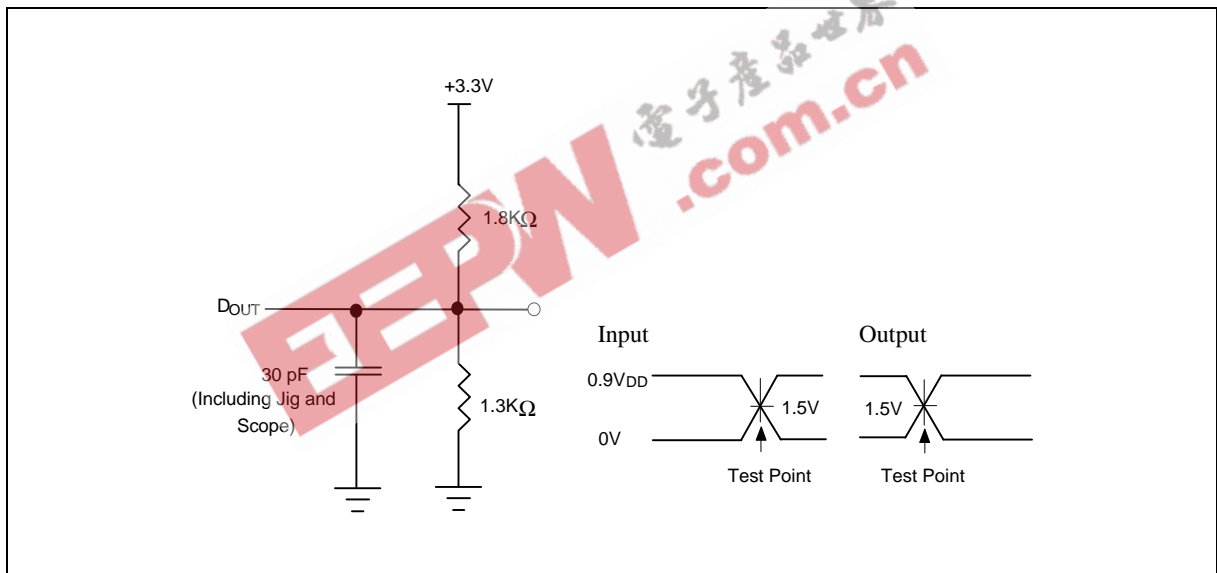



Programmer Interface Mode AC Characteristics, continued

AC Characteristics

Read Cycle Timing Parameters

(V_{DD} = 3.3V ± 5%, V_{GND} = 0V, T_A = 0 to 70° C)

PARAMETER	SYMBOL	W49V002FA		UNIT
		MIN.	MAX.	
Read Cycle Time	TRC	300	-	nS
Row/Column Address Set Up Time	TAS	50	-	nS
Row/Column Address Hold Time	TAH	50	-	nS
Address Access Time	TAA	-	200	nS
Output Enable Access Time	TOE	-	100	nS
#OE Low to Active Output	TOLZ	0	-	nS
#OE High to High-Z Output	TOHZ	-	50	nS
Output Hold from Address Change	TOH	0	-	nS

Write Cycle Timing Parameters

PARAMETER	SYMBOL	MIN.	TYP.	MAX.	UNIT
Reset Time	TRST	1	-	-	μS
Address Setup Time	TAS	50	-	-	nS
Address Hold Time	TAH	50	-	-	nS
R/#C to Write Enable High Time	TCWH	50	-	-	nS
#WE Pulse Width	TWP	100	-	-	nS
#WE High Width	TWPH	100	-	-	nS
Data Setup Time	TDS	50	-	-	nS
Data Hold Time	TDH	50	-	-	nS
#OE Hold Time	TOEH	0	-	-	nS
Byte programming Time	TBP	-	50	100	μS
Erase Cycle Time	TEC	-	0.15	0.2	S

Note: All AC timing signals observe the following guidelines for determining setup and hold times:

- (a) High level signal's reference level is input high and (b) low level signal's reference level is input low.
Ref. to the AC testing condition.

Data Polling and Toggle Bit Timing Parameters

PARAMETER	SYMBOL	W49V002FA		UNIT
		MIN.	MAX.	
#OE to Data Polling Output Delay	TOEP	-	40	nS
#OE to Toggle Bit Output Delay	TOET	-	40	nS



TIMING WAVEFORMS FOR PROGRAMMER INTERFACE MODE

Read Cycle Timing Diagram

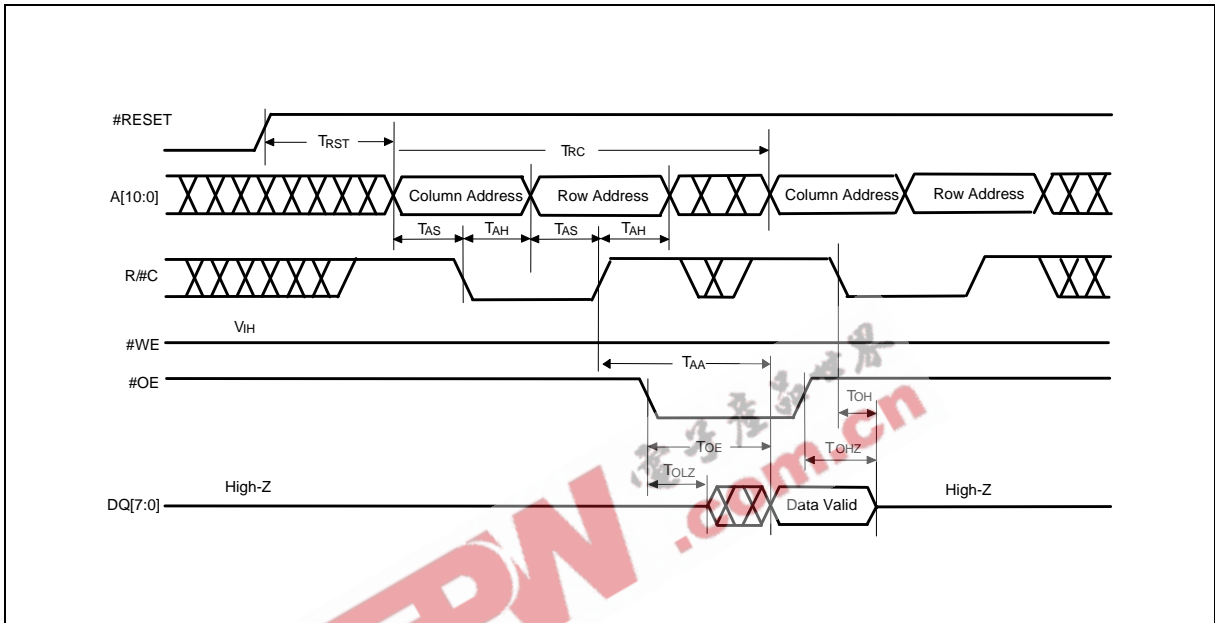

Write Cycle Timing Diagram

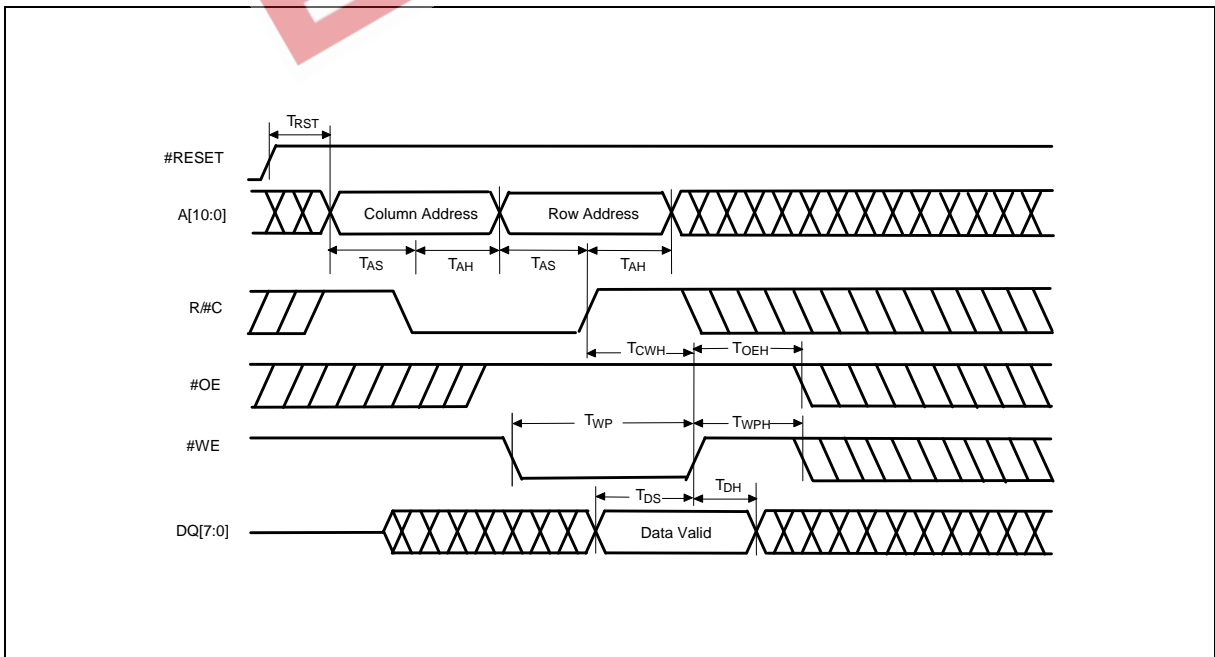



Timing Waveforms for Programmer Interface Mode, continued

Program Cycle Timing Diagram

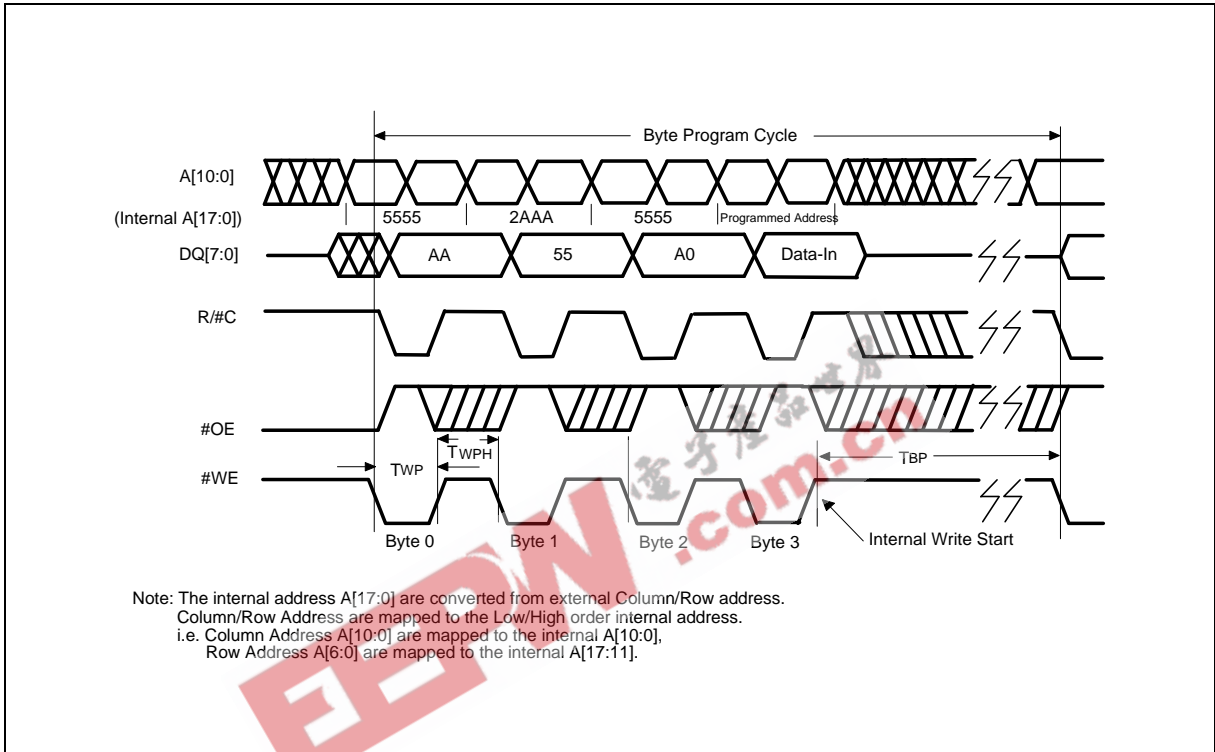

#DATA Polling Timing Diagram

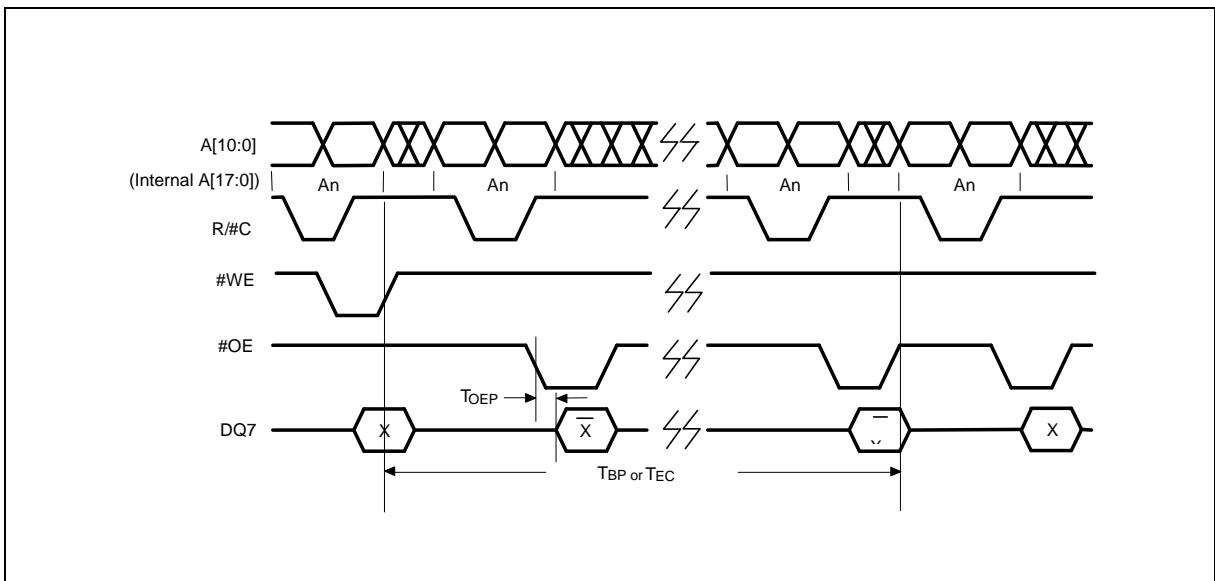



Timing Waveforms for Programmer Interface Mode, continued

Toggle Bit Timing Diagram

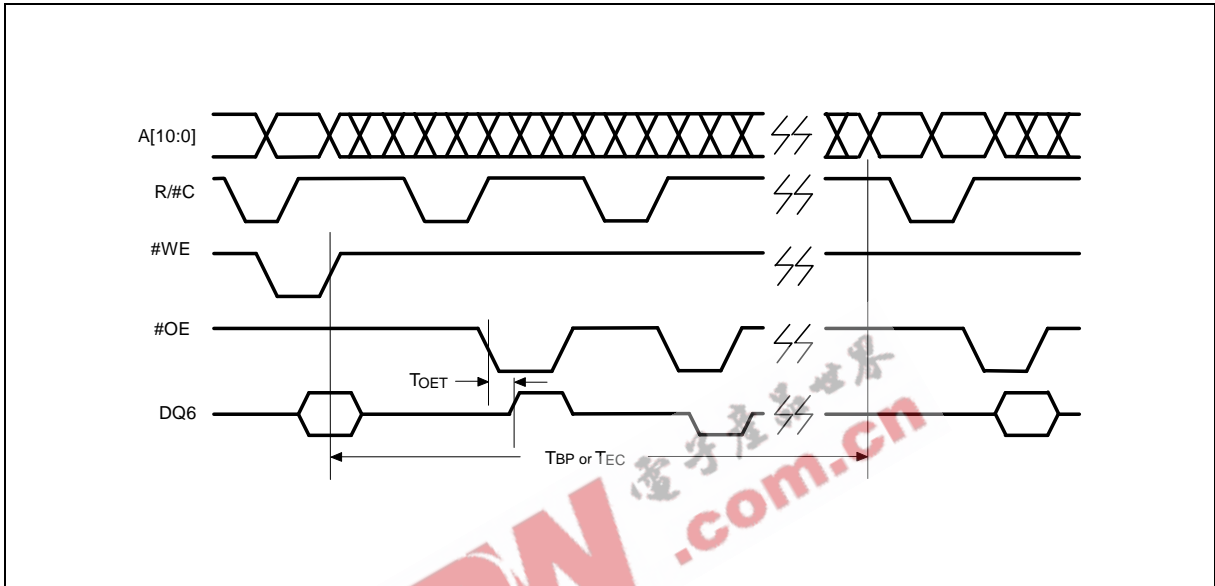

Boot Block Lockout Enable Timing Diagram

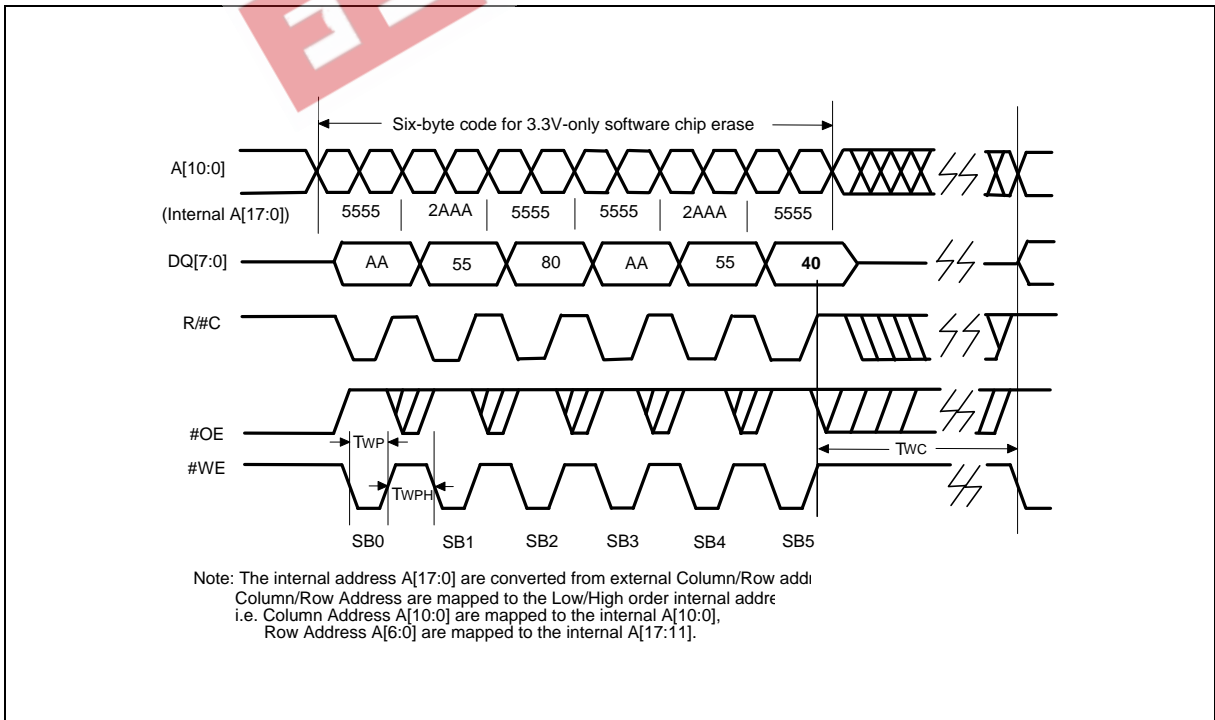



Timing Waveforms for Programmer Interface Mode, continued

Chip Erase Timing Diagram

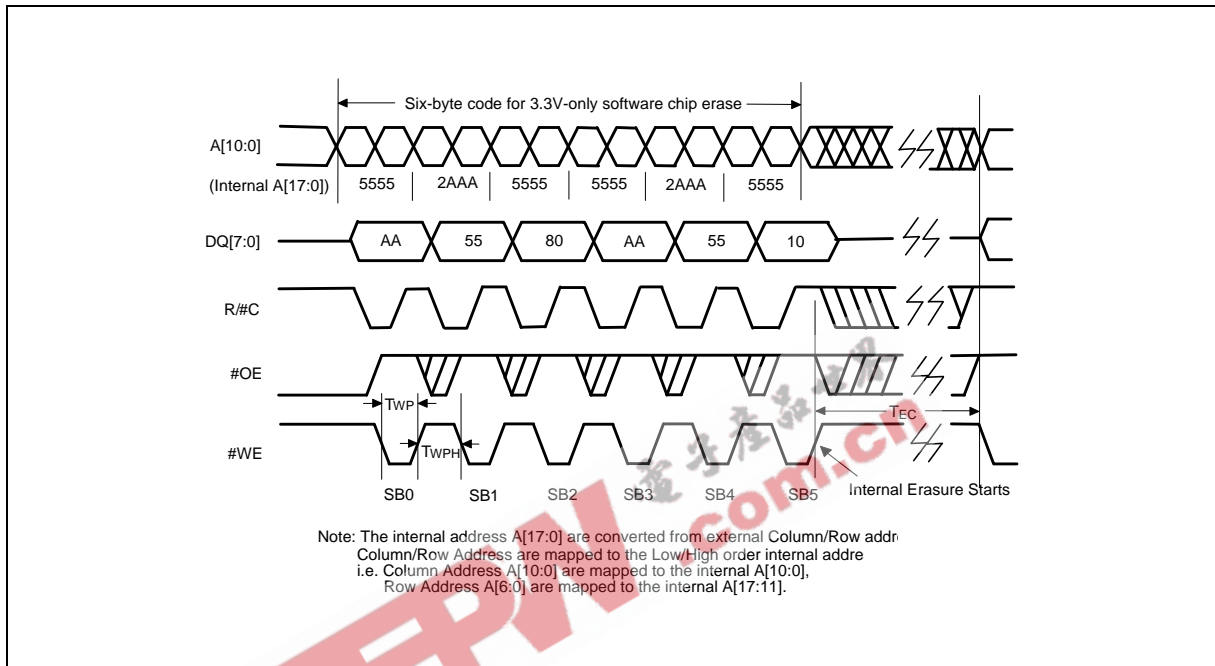

Sector Erase Timing Diagram

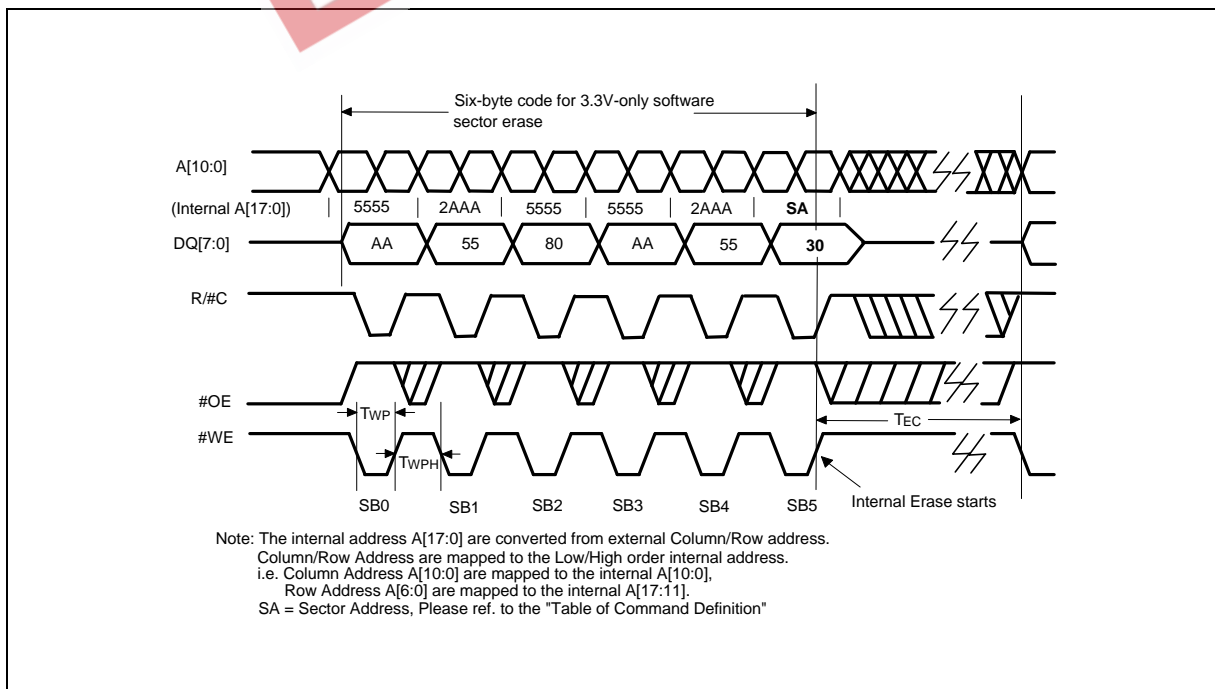



FWH INTERFACE MODE AC CHARACTERISTICS

AC Test Conditions

PARAMETER	CONDITIONS
Input Pulse Levels	0.6 V _{DD} to 0.2 V _{DD}
Input Rise/Fall Slew Rate	1 V/nS
Input/Output Timing Level	0.4 V _{DD} / 0.4 V _{DD}
Output Load	1 TTL Gate and CL = 10 pF

AC Test Load and Waveform

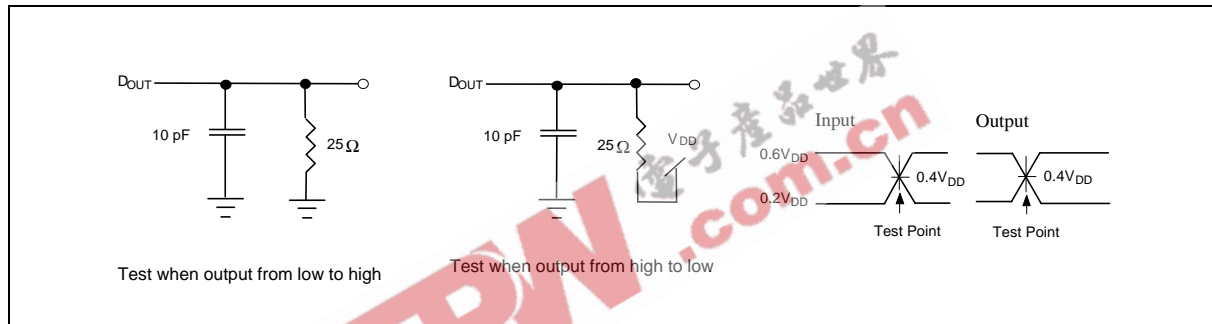

Read/Write Cycle Timing Parameters

(V_{DD} = 3.3V ± 5%, V_{GND} = 0V, T_A = 0 to 70° C)

PARAMETER	SYMBOL	W49V002FA		UNIT
		MIN.	MAX.	
Clock Cycle Time	TCYC	30	-	nS
Input Set Up Time	TSU	7	-	nS
Input Hold Time	THD	0	-	nS
Clock to Data Valid	TKQ	-	11	nS

Reset Timing Parameters

PARAMETER	SYM.	MIN.	TYP.	MAX.	UNIT
V _{DD} stable to Reset Active	TPRST	1	-	-	mS
Clock Stable to Reset Active	TKRST	100	-	-	μS
Reset Pulse Width	TRSTP	100	-	-	nS
Reset Active to Output Float	TRSTF	-	-	50	nS
Reset Inactive to Input Active	TRST	1	-	-	μS

Note: All AC timing signals observe the following guidelines for determining setup and hold times:

- (a) High level signal's reference level is input high and (b) low level signal's reference level is input low.
- Ref. to the AC testing condition.



TIMING WAVEFORMS FOR FWH INTERFACE MODE

Read Cycle Timing Diagram

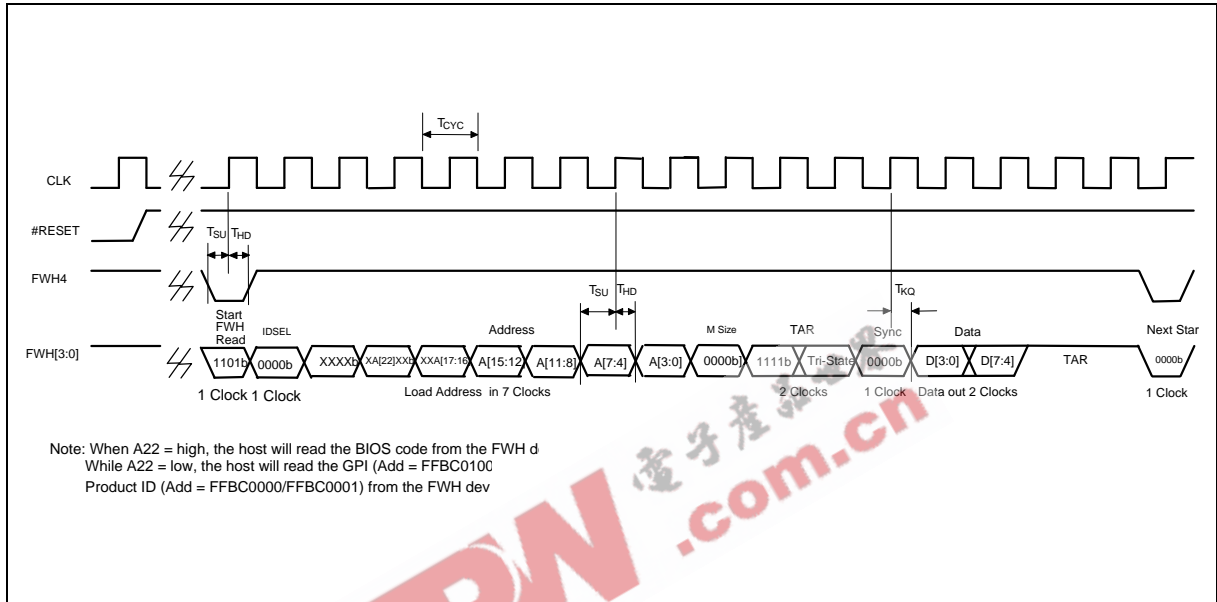

Write Cycle Timing Diagram

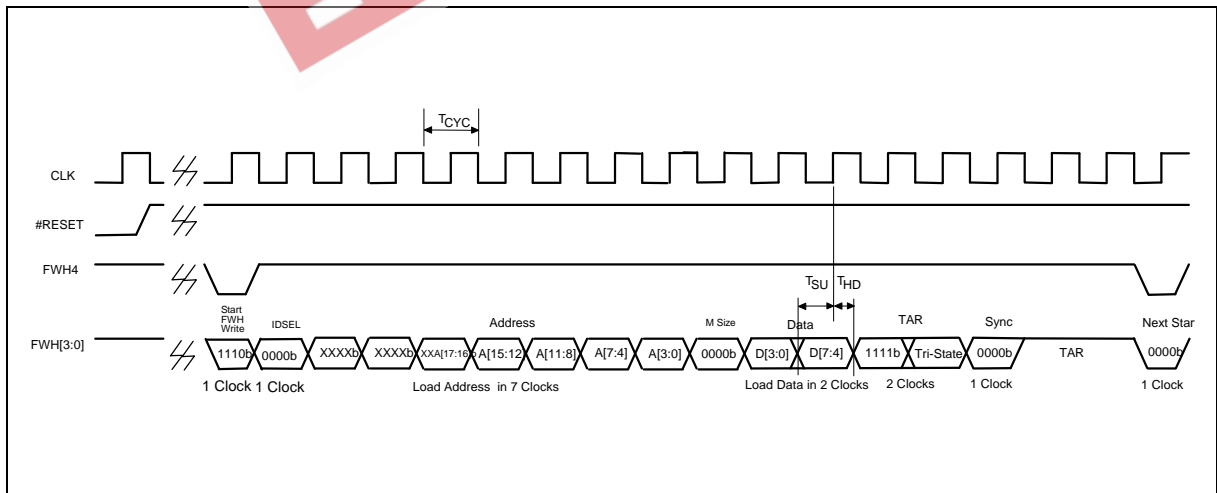



Timing Waveforms for FWH Interface Mode, continued

Program Cycle Timing Diagram

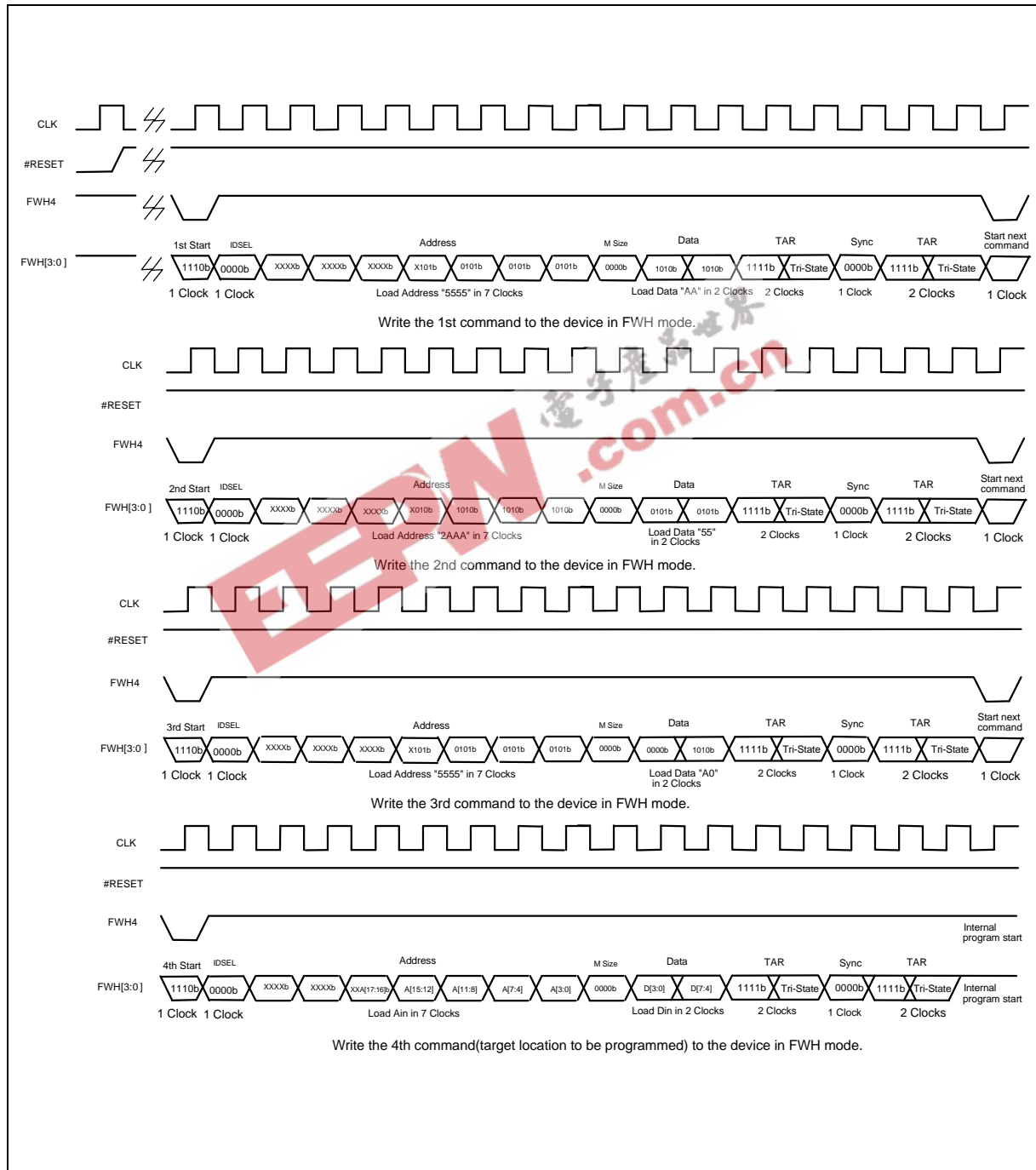



Timing Waveforms for FWH Interface Mode, continued

#DATA Polling Timing Diagram

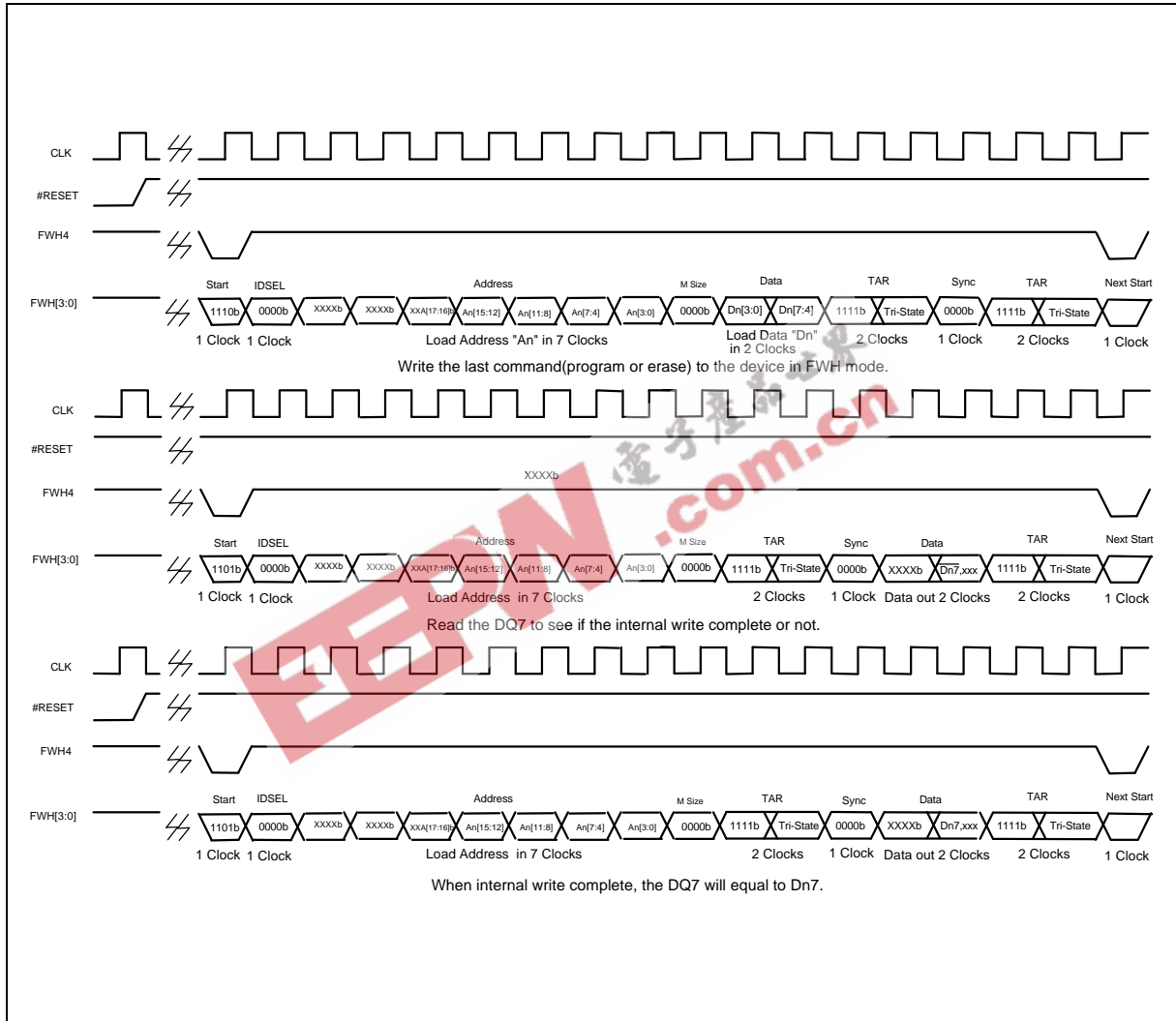



Timing Waveforms for FWH Interface Mode, continued

Toggle Bit Timing Diagram

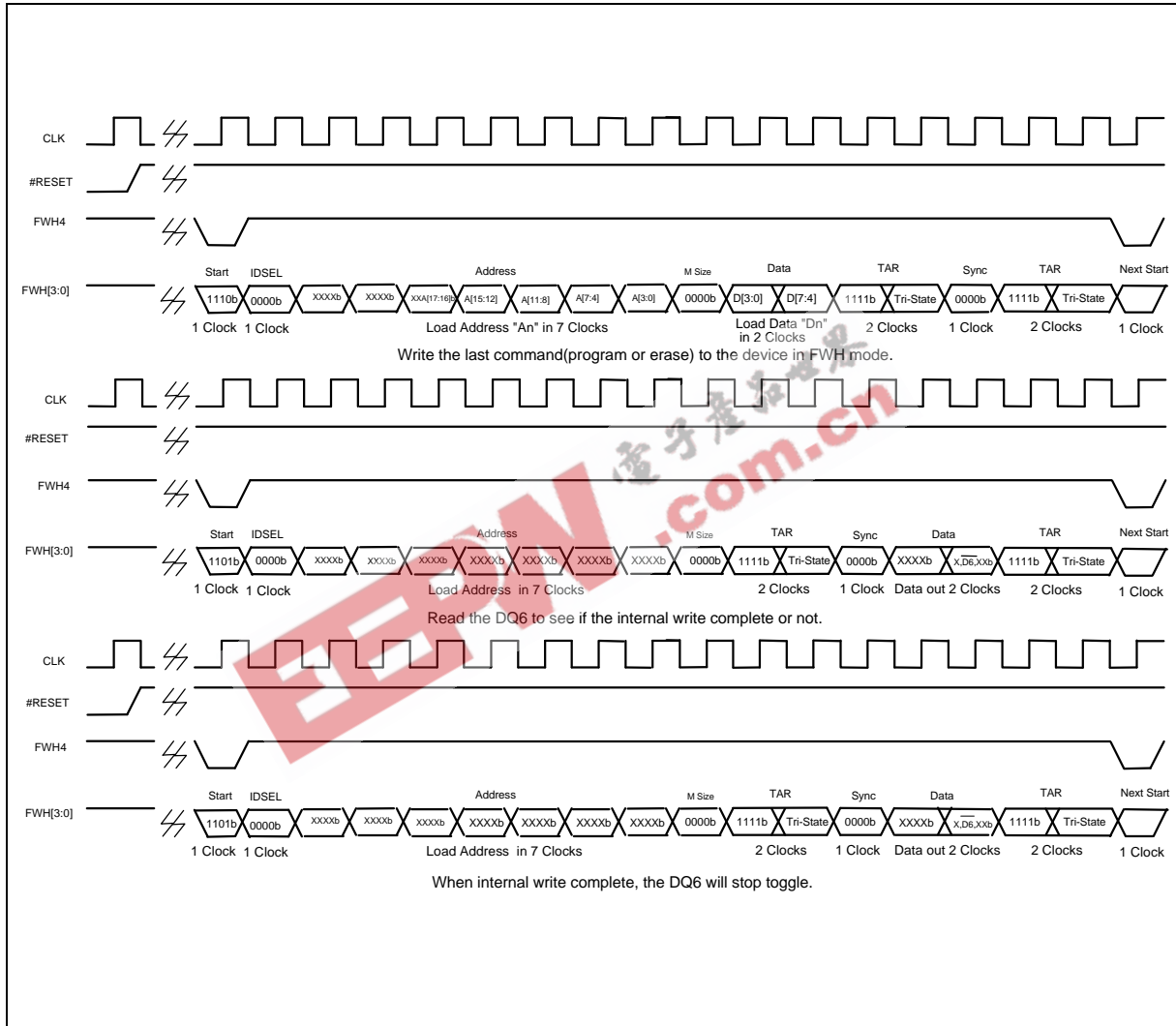



Timing Waveforms for FWH Interface Mode, continued

Boot Block Lockout Enable Timing Diagram

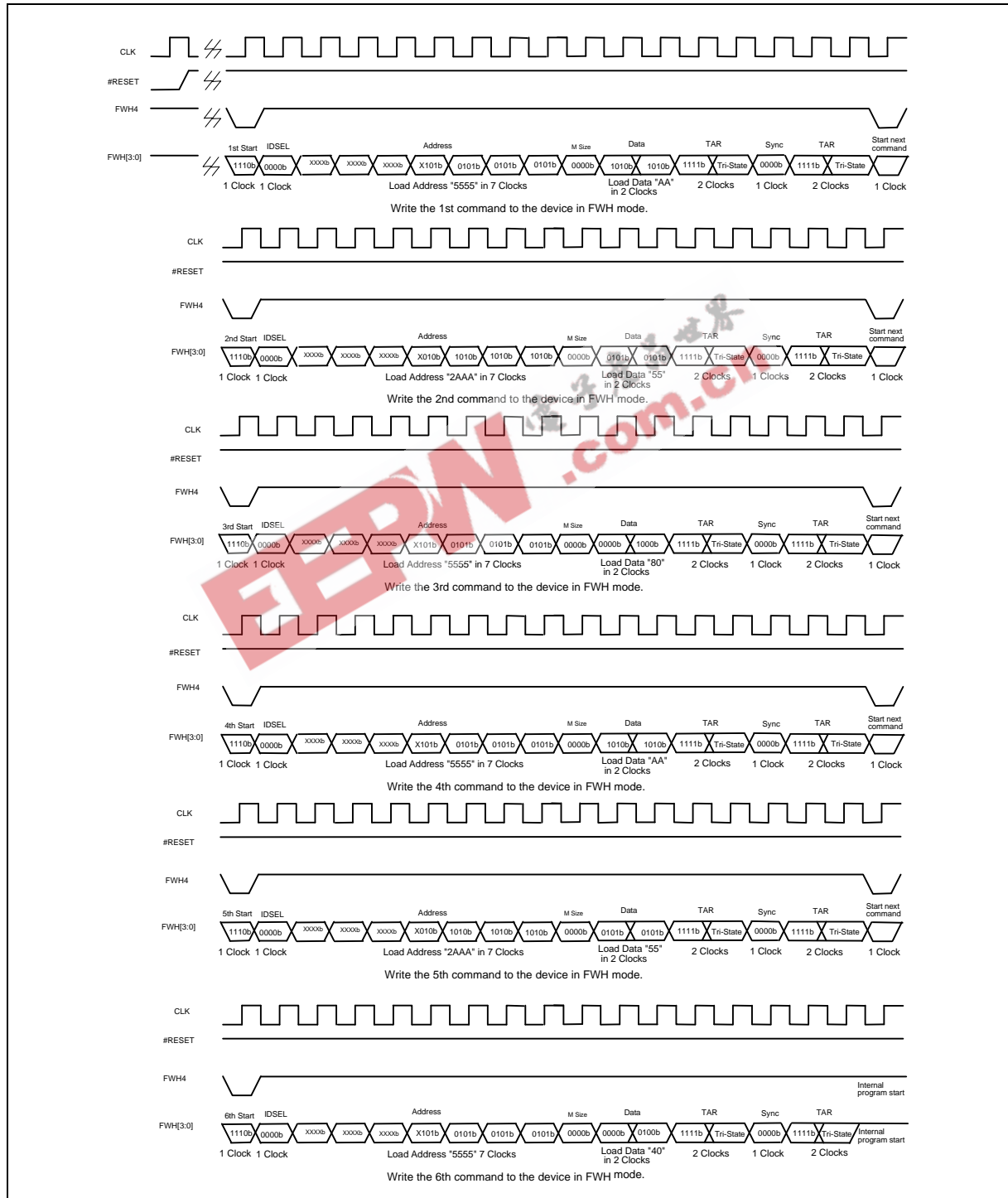



Timing Waveforms for FWH Interface Mode, continued

Chip Erase Timing Diagram

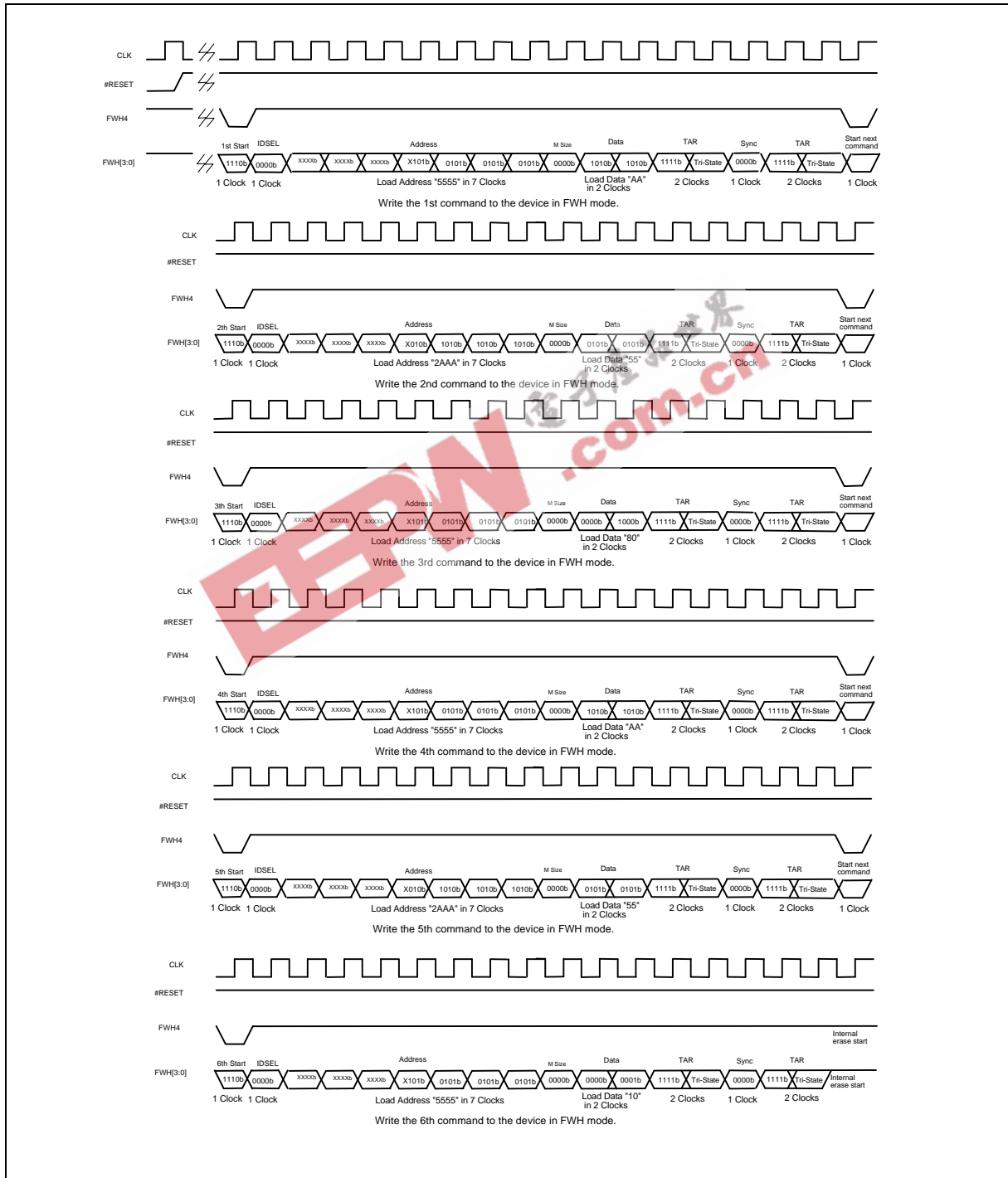



Timing Waveforms for FWH Interface Mode, continued

Sector Erase Timing Diagram

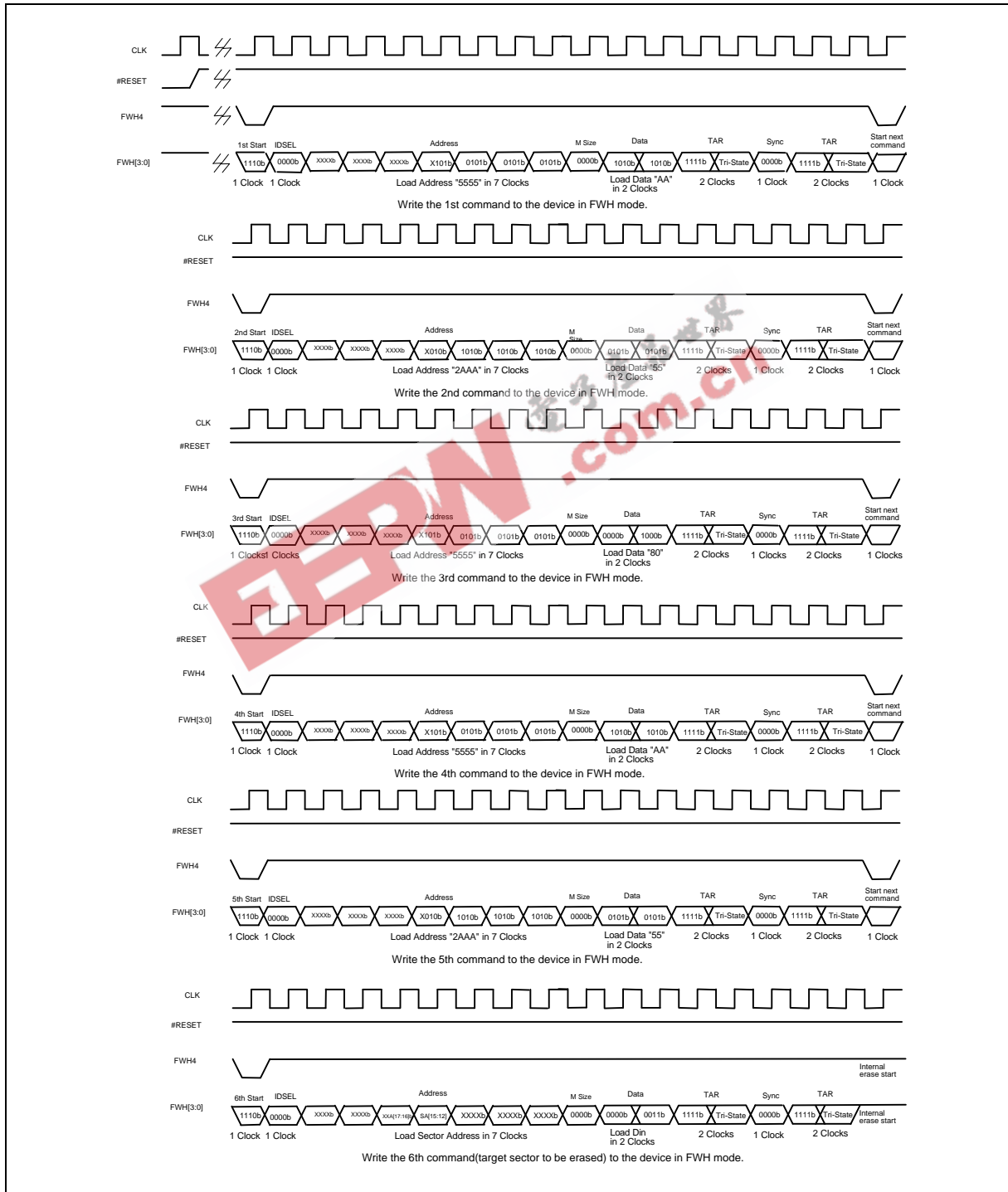



Timing Waveforms for FWH Interface Mode, continued

FGPI Register/Product ID Readout Timing Diagram

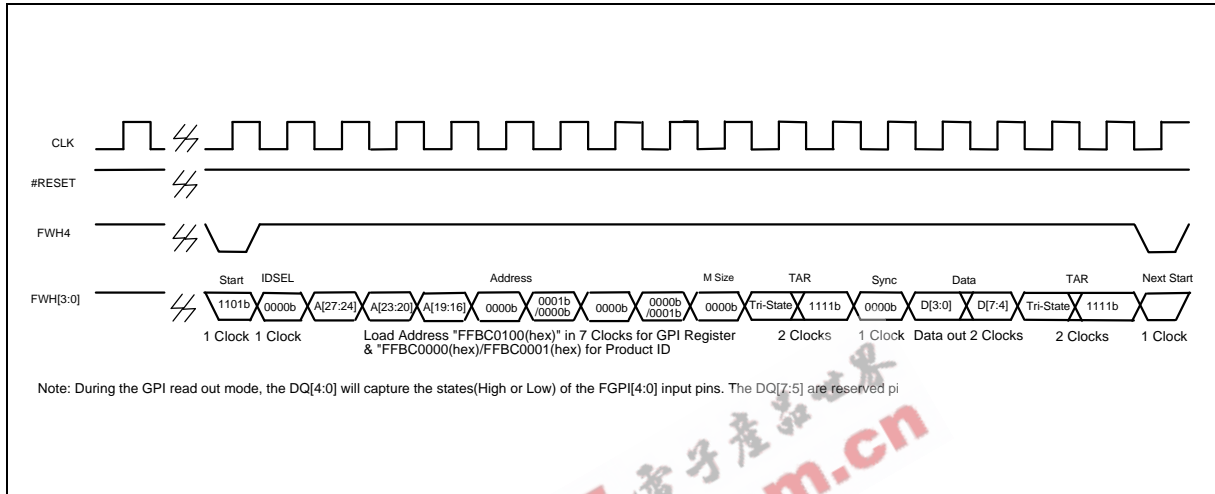

Reset Timing Diagram

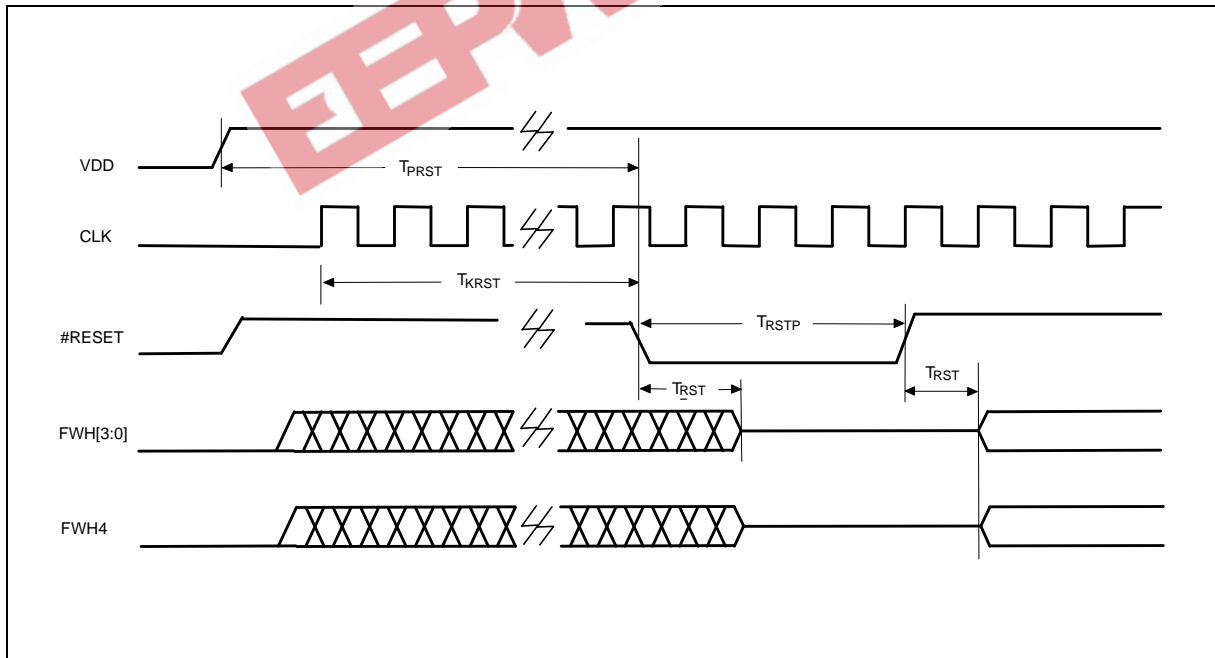



ORDERING INFORMATION

PART NO.	ACCESS TIME (nS)	POWER SUPPLY CURRENT MAX. (mA)	STANDBY V _{DD} CURRENT MAX. (mA)	PACKAGE
W49V002FAP	11	25	20	32L PLCC
W49V002FAQ	11	25	20	32L STSOP

Notes:

1. Winbond reserves the right to make changes to its products without prior notice.
2. Purchasers are responsible for performing appropriate quality assurance testing on products intended for use in applications where personal injury might occur as a consequence of product failure.

HOW TO READ THE TOP MARKING

Example: The top marking of 32L-PLCC W49V002FA



1st line: winbond logo

2nd line: the part number: W49V002FAP

3rd line: the lot number

4th line: the tracking code: 132 G H SA

132: Packages made in '01, week 32

G: Assembly house ID: A means ASE, G means Greatek, ...etc.

H: IC revision; A means version A, H means version H, ...etc.

SA: Process code



PACKAGE DIMENSIONS

32L PLCC

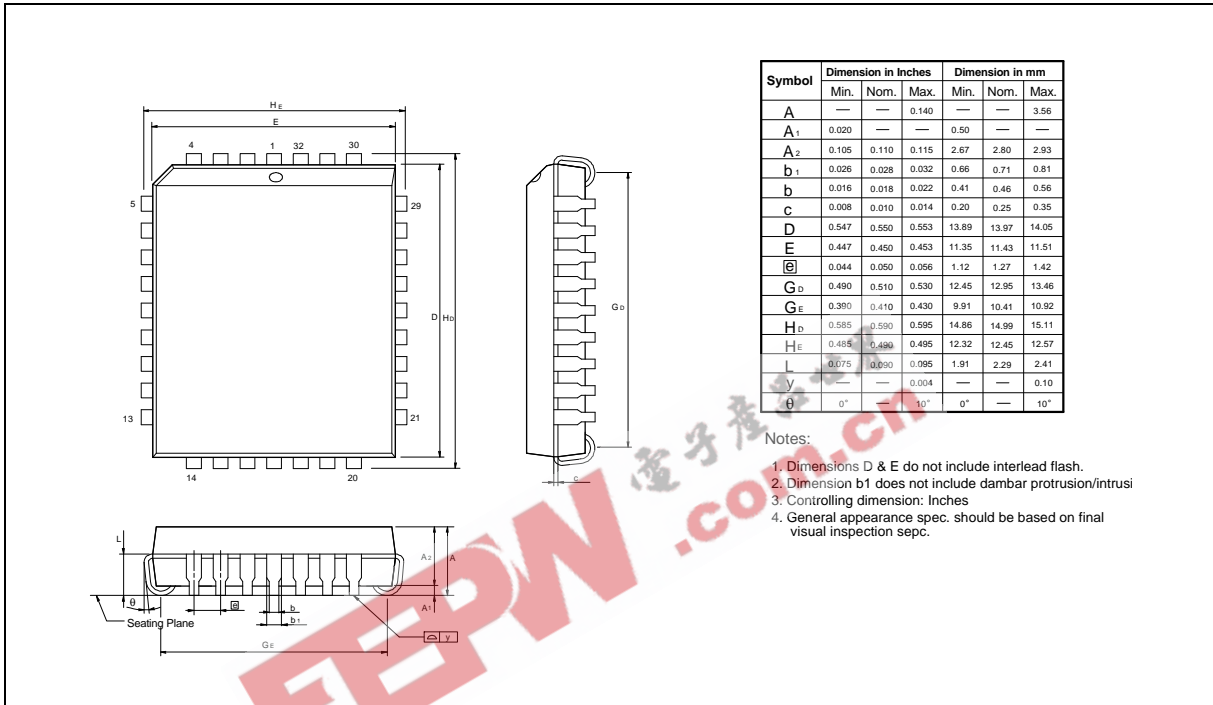

32L STSOP (8 x 14 mm)

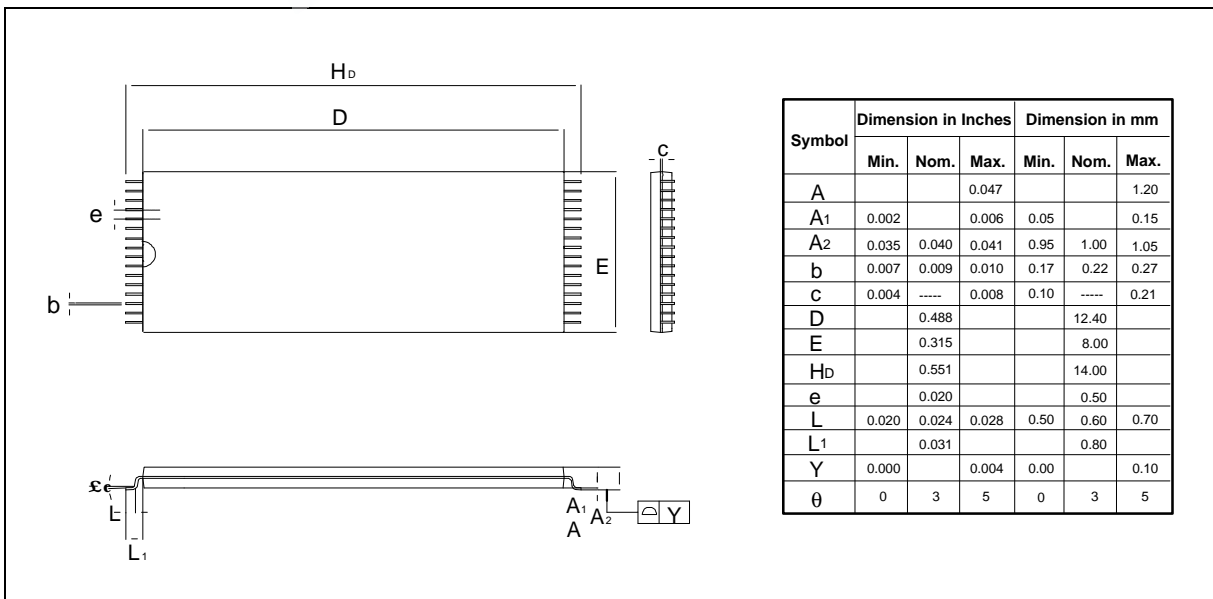



VERSION HISTORY

VERSION	DATE	PAGE	DESCRIPTION
A1	April 2001	-	Initial Issued
A2	Feb. 19, 2002	4	Modify VDD Power Up/Down Detection in Hardware Data Protection
		6	Modify the description on start in TABLE OF COMMAND DEFINITION
		7 – 10	Delete old flow chart and add embedded algorithm
		13	Add in Input High Voltage for #INIT (VIHI) parameter
			Change VIL (max.) from 0.2 VDD to 0.3 VDD; VIH (min.) from 0.6 VDD to 0.5 VDD. Add the VIH/ VILI for the #INIT pin input spec.
29	Add HOW TO READ THE TOP MARKING		

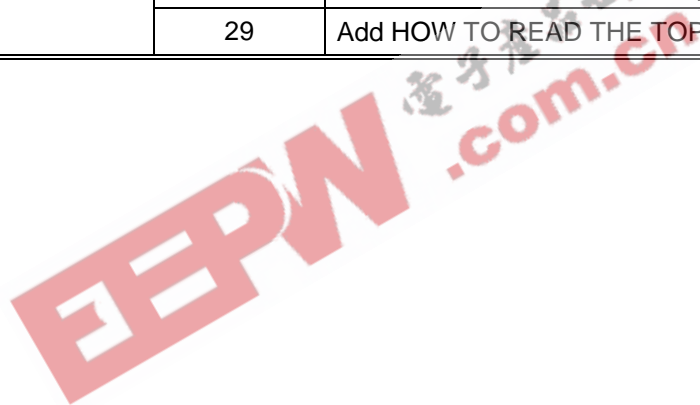

Headquarters
 No. 4, Creation Rd. III,
 Science-Based Industrial Park,
 Hsinchu, Taiwan
 TEL: 886-3-5770066
 FAX: 886-3-5665577
<http://www.winbond.com.tw/>

Taipei Office
 9F, No.480, Rueiguang Rd.,
 Neihu Chiu, Taipei, 114,
 Taiwan, R.O.C.
 TEL: 886-2-8177-7168
 FAX: 886-2-8751-3579

Winbond Electronics Corporation America
 2727 North First Street, San Jose,
 CA 95134, U.S.A.
 TEL: 1-408-9436666
 FAX: 1-408-5441798

Winbond Electronics Corporation Japan
 7F Daini-ueno BLDG, 3-7-18
 Shinyokohama Kohoku-ku,
 Yokohama, 222-0033
 TEL: 81-45-4781881
 FAX: 81-45-4781800

Winbond Electronics (Shanghai) Ltd.
 27F, 2299 Yan An W. Rd. Shanghai,
 200336 China
 TEL: 86-21-62365999
 FAX: 86-21-62365998

Winbond Electronics (H.K.) Ltd.
 Unit 9-15, 22F, Millennium City,
 No. 378 Kwun Tong Rd.,
 Kowloon, Hong Kong
 TEL: 852-27513100
 FAX: 852-27552064

*Please note that all data and specifications are subject to change without notice.
 All the trade marks of products and companies mentioned in this data sheet belong to their respective owners.*