



32K × 8 CMOS STATIC RAM

GENERAL DESCRIPTION

The W24257 is a slow speed, low power CMOS static RAM organized as 32768 × 8 bits that operates on a single 5-volt power supply. This device is manufactured using Winbond's high performance CMOS technology.

FEATURES

- Low power consumption:
 - Active: 325 mW (max.)
 - Standby: 75 μW (max.) (LL-version)
150 μW (max.) (L-version)
- Access time: 70 nS (max.)
- Single +5V power supply
- Fully static operation
- All inputs and outputs directly TTL compatible
- Three-state outputs
- Battery back-up operation capability
- Data retention voltage: 2V (min.)
- Packaged in 28-pin 330 mil SOP, standard type one TSOP (8 mm x 13.4 mm)

PIN CONFIGURATIONS

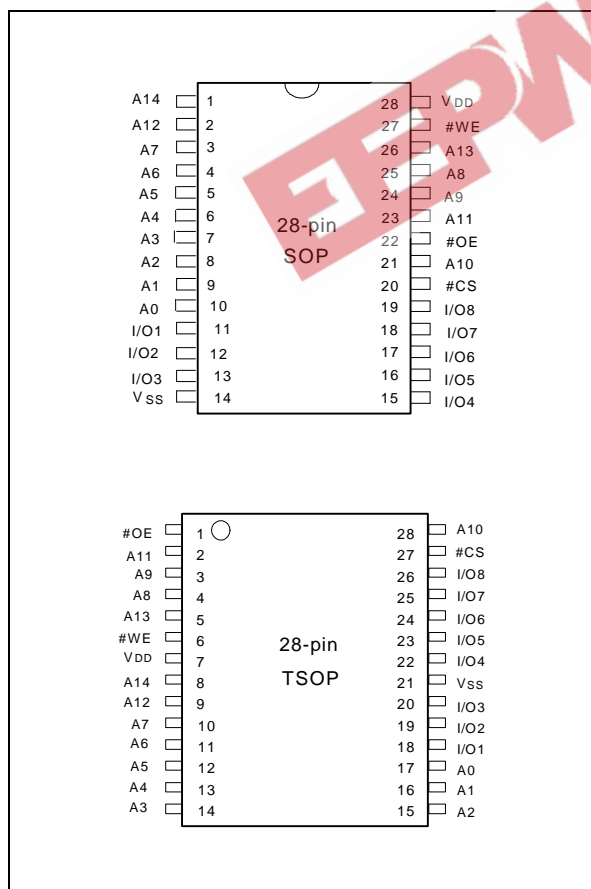

BLOCK DIAGRAM

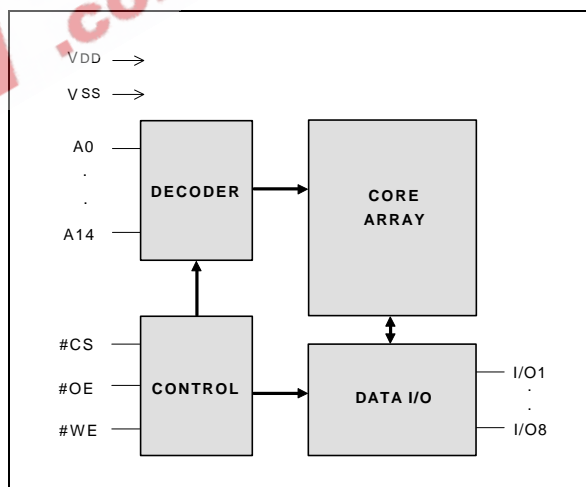

PIN DESCRIPTION

SYMBOL	DESCRIPTION
A0–A14	Address Inputs
I/O1–I/O8	Data Inputs/Outputs
#CS	Chip Select Input
#WE	Write Enable Input
#OE	Output Enable Input
V _{DD}	Power Supply
V _{SS}	Ground



TRUTH TABLE

#CS	#OE	#WE	MODE	I/O1- I/O8	V _{DD} CURRENT
H	X	X	Not Selected	High Z	ISB, ISB1
L	H	H	Output Disable	High Z	IDD
L	L	H	Read	Data Out	IDD
L	X	L	Write	Data In	IDD

DC CHARACTERISTICS

Absolute Maximum Ratings

PARAMETER	RATING	UNIT
Supply Voltage to V _{SS} Potential	-0.5 to +7.0	V
Input/Output to V _{SS} Potential	-0.5 to V _{DD} +0.5	V
Allowable Power Dissipation	1.0	W
Storage Temperature	-65 to +150	°C
Operating Temperature	0 to +70	°C

Note: Exposure to conditions beyond those listed under Absolute Maximum Ratings may adversely affect the life and reliability of the device.

Operating Characteristics

(V_{DD} = 5V ±10%, V_{SS} = 0V, T_A = 0 to 70° C for LL/L; -20 to 85° C for LE)

PARAMETER	SYM.	TEST CONDITIONS	MIN.	TYP.	MAX.	UNIT
Input Low Voltage	V _{IL}	-	-0.5	-	+0.8	V
Input High Voltage	V _{IH}	-	+2.2	-	V _{DD} +0.5	V
Input Leakage Current	I _{LI}	V _{IN} = V _{SS} to V _{DD}	-2	-	+2	μA
Output Leakage Current	I _{LO}	V _{I/O} = V _{SS} to V _{DD} , #CS = V _{IH} (min.) or #OE = V _{IH} (min.) or #WE = V _{IL} (max.)	-2	-	+2	μA
Output Low Voltage	V _{OL}	I _{OL} = +4.0 mA	-	-	0.4	V
Output High Voltage	V _{OH}	I _{OH} = -1.0 mA	2.4	-	-	V
Operating Power Supply Current	IDD	#CS = V _{IL} (min.), I/O = 0 mA Cycle = min., Duty = 100%	-	-	70	mA
Standby Power Supply Current	ISB	#CS = V _{IH} (min.) Cycle = min., Duty = 100%	-	-	3	mA
			#CS ≥ V _{DD} -0.2V	LL/LE	-	-
	L	-		-	30	μA

Note: Typical characteristics are at V_{DD} = 5V, T_A = 25° C.



CAPACITANCE

(V_{DD} = 5V, T_A = 25° C, f = 1 MHz)

PARAMETER	SYM.	CONDITIONS	MAX.	UNIT
Input Capacitance	C _{IN}	V _{IN} = 0V	6	pF
Input/Output Capacitance	C _{I/O}	V _{OUT} = 0V	8	pF

Note: These parameters are sampled but not 100% tested.

AC CHARACTERISTICS

AC Test Conditions

PARAMETER	CONDITIONS
Input Pulse Levels	0.6V to 2.4V
Input Rise and Fall Times	5 nS
Input and Output Timing Reference Level	1.5V
Output Load	C _L = 100 pF, I _{OH} /I _{OL} = -1 mA/4 mA

AC Test Loads and Waveform

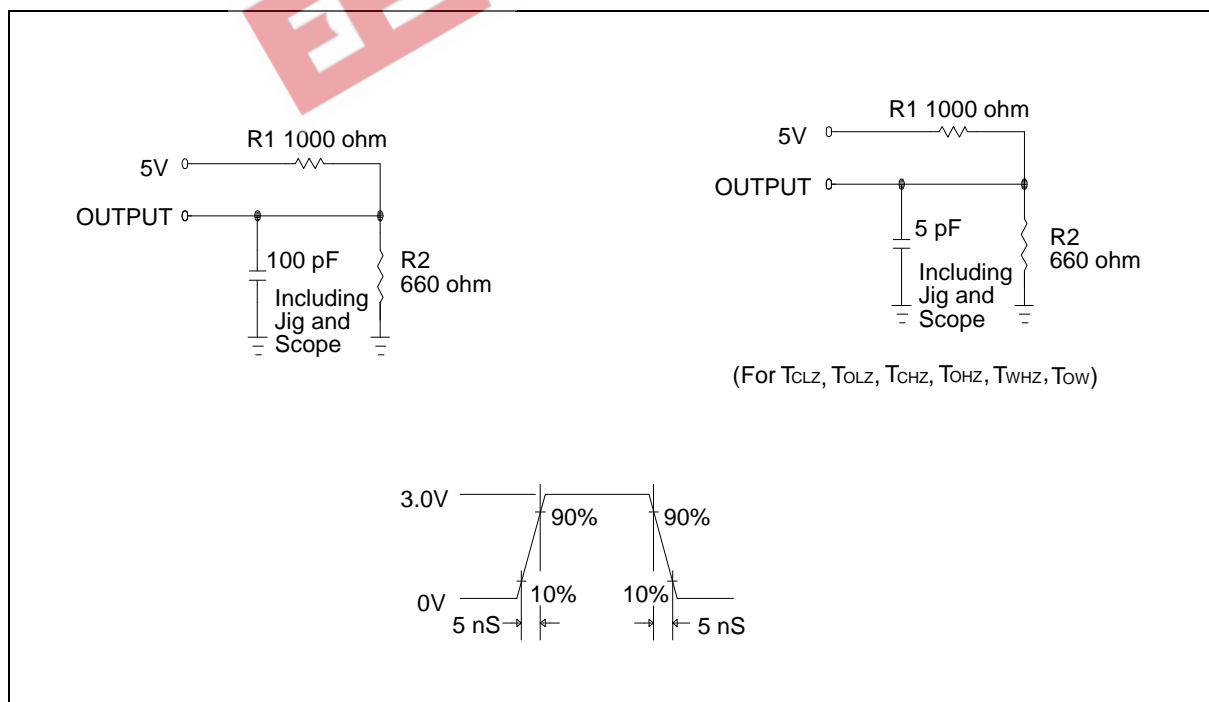



AC Characteristics, continued

(V_{DD} = 5V ±10%, V_{SS} = 0V, T_A = 0 to 70° C for LL/L; -20 to 85° C for LE)**Read Cycle**

PARAMETER	SYMBOL	W24257-70		UNIT
		MIN.	MAX.	
Read Cycle Time	TRC	70	-	nS
Address Access Time	TAA	-	70	nS
Chip Select Access Time	TACS	-	70	nS
Output Enable to Output Valid	TAOE	-	35	nS
Chip Selection to Output in Low Z	TCLZ*	10	-	nS
Output Enable to Output in Low Z	TOLZ*	5	-	nS
Chip Deselection to Output in High Z	TCHZ*	-	30	nS
Output Disable to Output in High Z	TOHZ*	-	30	nS
Output Hold from Address Change	TOH	10	-	nS

* These parameters are sampled but not 100% tested

Write Cycle

PARAMETER		SYMBOL	W24257-70		UNIT
			MIN.	MAX.	
Write Cycle Time		TWC	70	-	nS
Chip Selection to End of Write		TCW	60	-	nS
Address Valid to End of Write		TAW	60	-	nS
Address Setup Time		TAS	0	-	nS
Write Pulse Width		TWP	45	-	nS
Write Recovery Time	#CS, #WE	TWR	0	-	nS
Data Valid to End of Write		TDW	30	-	nS
Data Hold from End of Write		TDH	0	-	nS
Write to Output in High Z		TWHZ*	-	30	nS
Output Disable to Output in High Z		TOHZ*	-	30	nS
Output Active from End of Write		TOW	0	-	nS

* These parameters are sampled but not 100% tested



TIMING WAVEFORMS

Read Cycle 1

(Address Controlled)

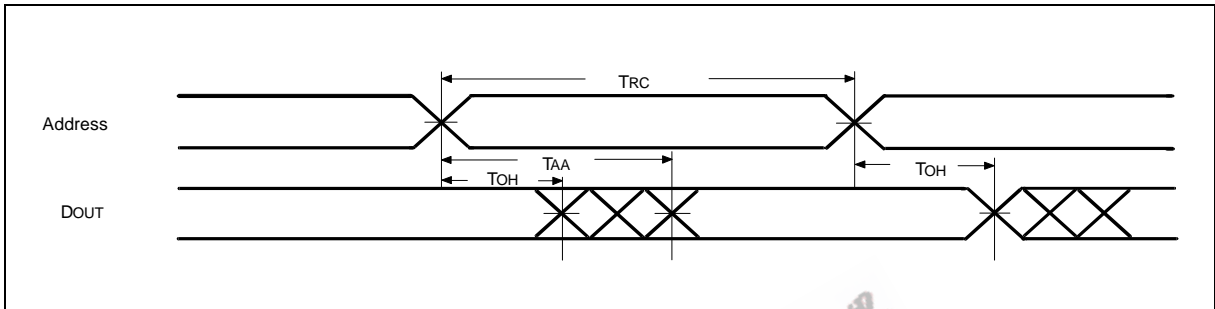

Read Cycle 2

(Chip Select Controlled)

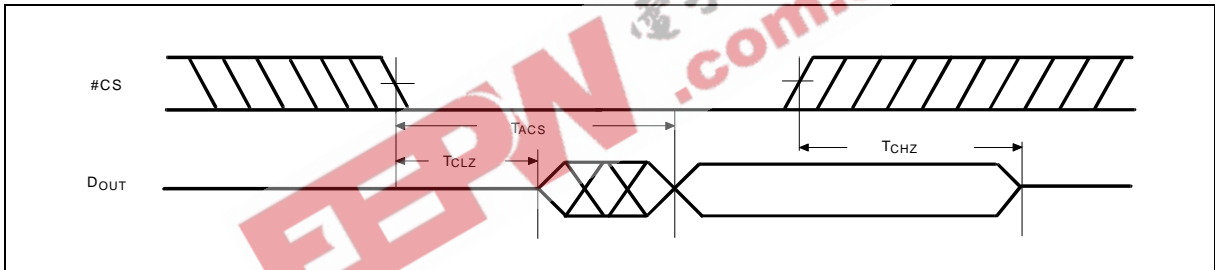

Read Cycle 3

(Output Enable Controlled)

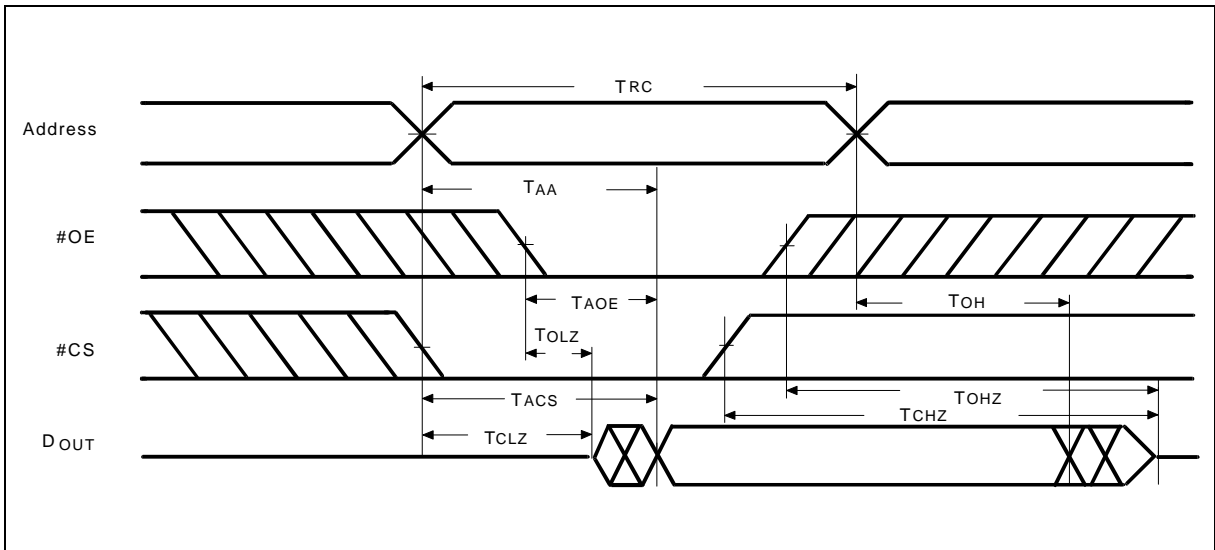

Timing Waveforms, continued

Write Cycle 1

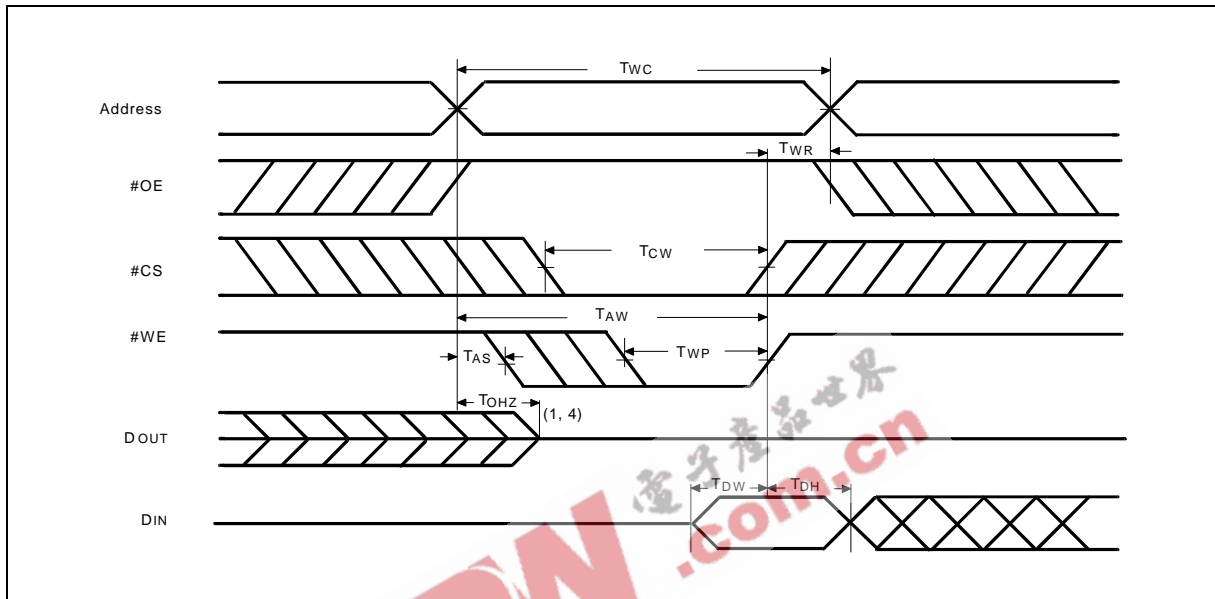

Write Cycle 2

($\overline{OE} = V_{IL}$ Fixed)

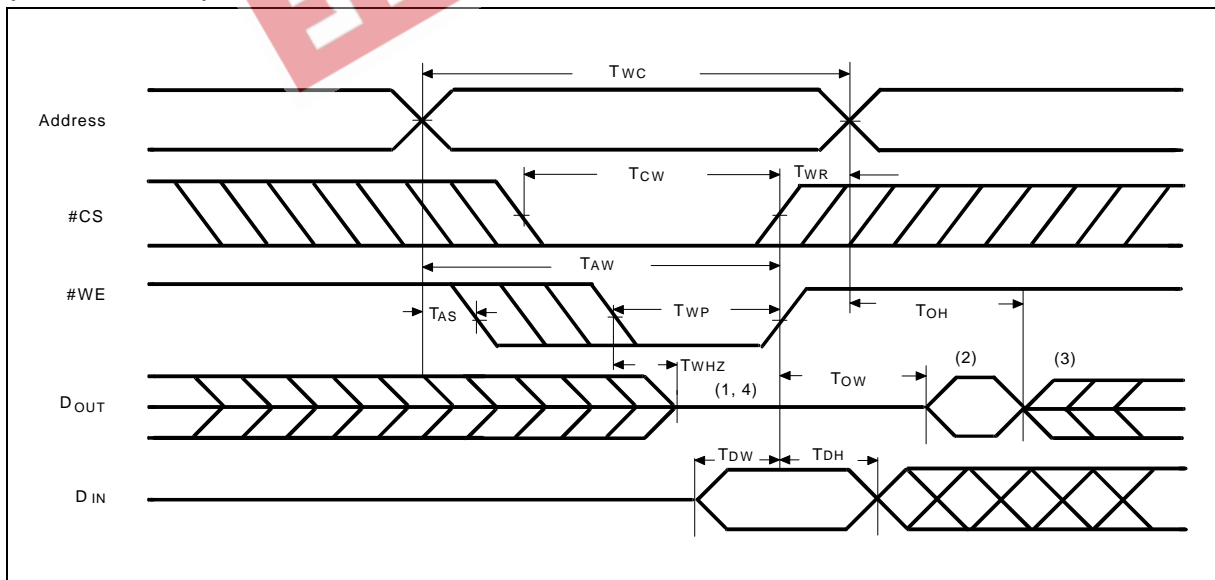

Notes:

1. During this period, I/O pins are in the output state, so input signals of opposite phase to the outputs should not be applied.
2. The data output from DOUT are the same as the data written to DIN during the write cycle.
3. DOUT provides the read data for the next address.
4. Transition is measured ± 500 mV from steady state with $C_L = 5$ pF. This parameter is guaranteed but not 100% tested.



DATA RETENTION CHARACTERISTICS

($T_A = 0$ to 70°C for LL/L; -20 to 85°C for LE)

PARAMETER	SYM.	TEST CONDITIONS	MIN.	TYP.	MAX.	UNIT	
VDD for Data Retention	VDR	#CS $\geq V_{DD} - 0.2V$	2.0	-	-	V	
Data Retention Current	IDDDR	#CS $\geq V_{DD} - 0.2V$ VDD = 3V	LL/LE	-	-	15	μA
			L	-	-	30	μA
Chip Deselect to Data Retention Time	TCDR	See data retention	0	-	-	nS	
Operation Recovery Time	TR	Waveform	TRC*	-	-	nS	

TRC* = Read Cycle Time

DATA RETENTION WAVEFORM

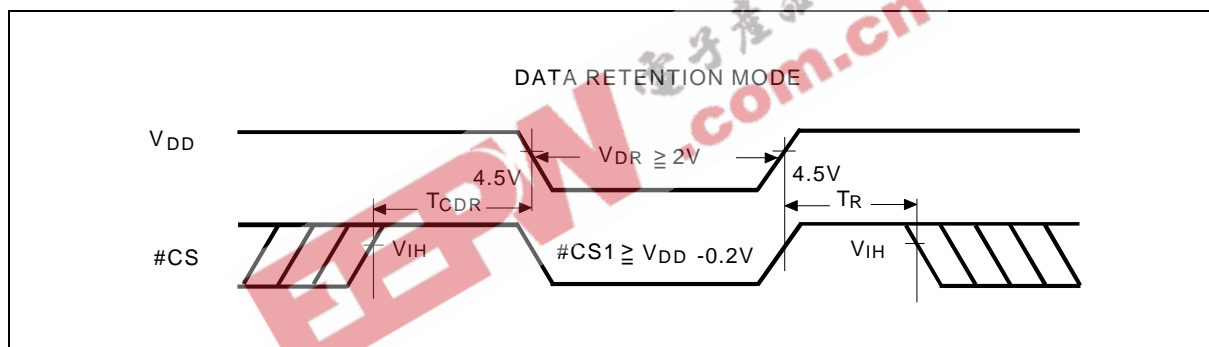

ORDERING INFORMATION

PART NO.	ACCESS TIME (nS)	OPERATING CURRENT MAX. (mA)	STANDBY CURRENT MAX. (mA)	OPERATING TEMP. ($^\circ\text{C}$)	PACKAGE
W24257S-70LL	70	70	15	0 to 70	330 mil SOP
W24257S-70L	70	70	30	0 to 70	330 mil SOP
W24257S-70LE	70	70	15	-20 to 85	330 mil SOP
W24257Q-70LL	70	70	15	0 to 70	Standard type one TSOP
W24257Q-70L	70	70	30	0 to 70	Standard type one TSOP
W24257Q-70LE	70	70	15	-20 to 85	Standard type one TSOP

Notes:

- Winbond reserves the right to make changes to its products without prior notice.
- Purchasers are responsible for performing appropriate quality assurance testing on products intended for use in applications where personal injury might occur as a consequence of product failure.



BONDING PAD DIAGRAM

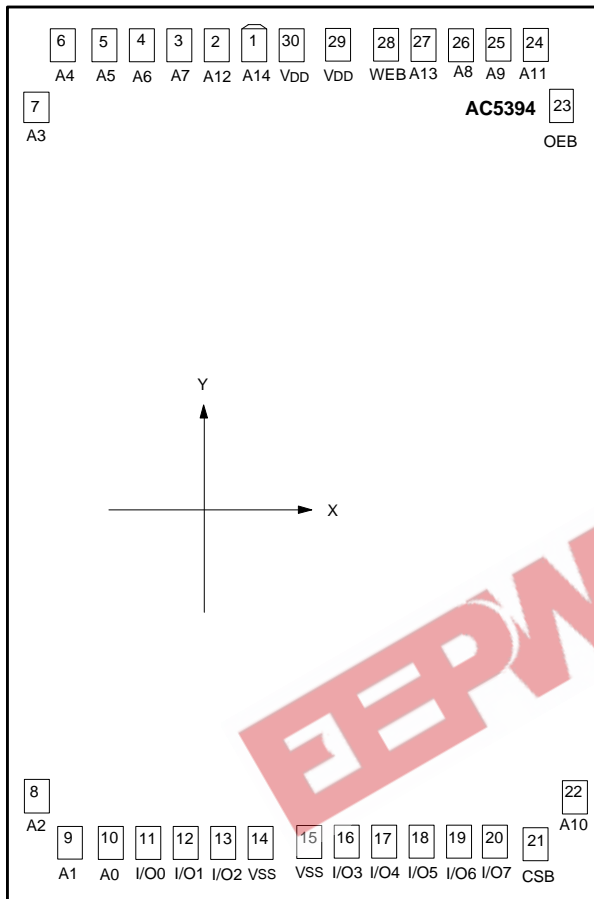

PAD NO.	X	Y
1	-232.25	1445.22
2	-351.70	1445.22
3	-471.15	1445.22
4	-590.60	1445.22
5	-710.05	1445.22
6	-829.50	1445.22
7	-992.79	1362.24
8	-992.79	-1306.11
9	-857.86	-1452.79
10	-738.41	-1452.79
11	-594.84	-1414.13
12	-451.06	-1414.13
13	-310.67	-1414.13
14	-171.78	-1405.28
15	24.45	-1405.28
16	151.80	-1414.13
17	298.07	-1414.13
18	443.28	-1414.13
19	588.20	-1414.13
20	732.84	-1414.13
21	871.11	-1452.79
22	992.75	-1312.15
23	992.75	1373.67
24	810.09	1445.22
25	690.64	1445.22
26	571.19	1445.22
27	451.74	1445.22
28	332.29	1445.22
29	120.25	1444.65
30	-93.23	1444.65

Note: For bare chip form (C.O.B.) applications, the substrate must be connected to VDD or left floating in the PCB layout.



PACKAGE DIMENSIONS

28-pin SO Wide Body

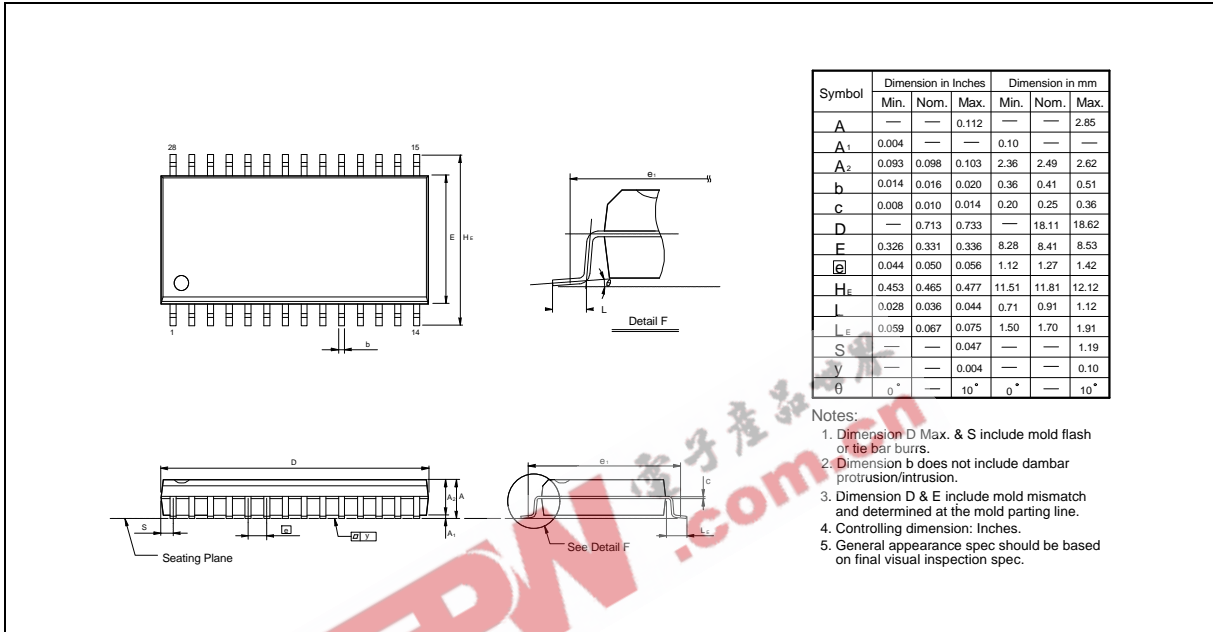

28-pin Standard Type One TSOP

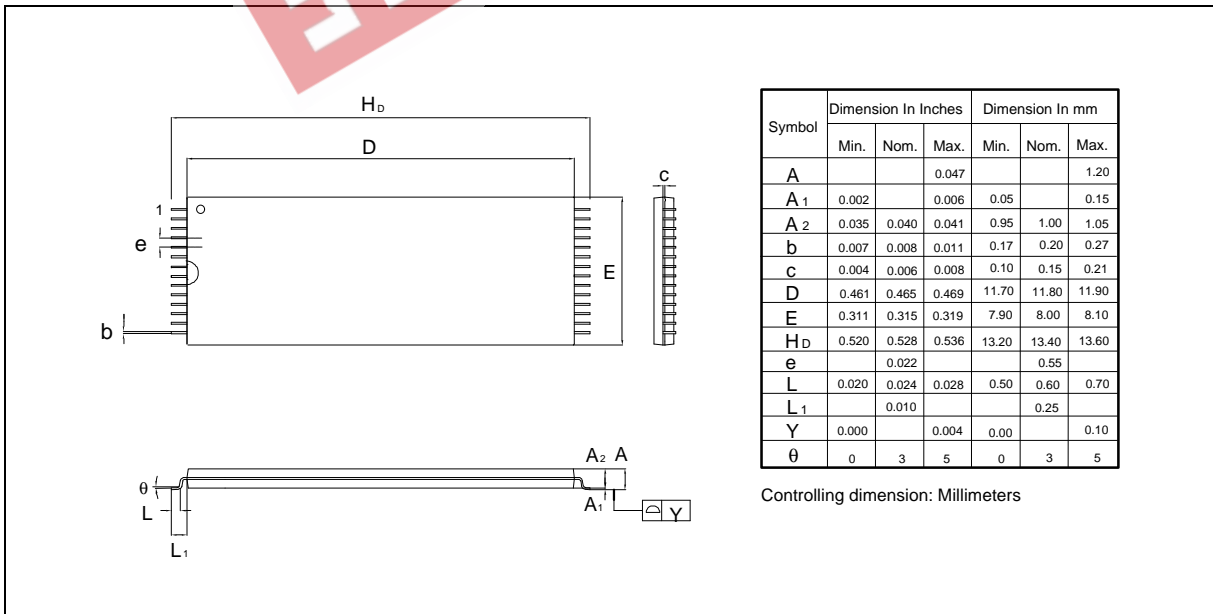



VERSION HISTORY

VERSION	DATE	PAGE	DESCRIPTION
A12	Nov. 1999	1, 2, 7	Change the IDD, ISB, ISB1
		4, 7	Remove the W24257-10 spc.
A13	Apr. 2000	7	Typo correction in Standby Current Max.: mA->μA
A14	May 2000	1, 7, 8	Delete 28-pin DIP Package
		8	Add in Bonding Pad Diagram
A15	Nov. 2000	2	Modify Operating Power Supply Current (IDD) as 70 mA
		1	Add in TSOP Pin Configuration
A16	Feb. 2001	2, 4, 7	Add in LE grade

EEPW.com.cn 电子產品世界

**Headquarters**

No. 4, Creation Rd. III,
Science-Based Industrial Park,
Hsinchu, Taiwan
TEL: 886-3-5770066
FAX: 886-3-5796096
<http://www.winbond.com.tw/>
Voice & Fax-on-demand: 886-2-27197006

Taipei Office

11F, No. 115, Sec. 3, Min-Sheng East Rd.,
Taipei, Taiwan
TEL: 886-2-27190505
FAX: 886-2-27197502

Winbond Electronics (H.K.) Ltd.

Unit 9-15, 22F, Millennium City,
No. 378 Kwun Tong Rd;
Kowloon, Hong Kong
TEL: 852-27513100
FAX: 852-27552064

Winbond Electronics North America Corp

Winbond Memory Lab.
Winbond Microelectronics Corp.
Winbond Systems Lab.
2727 N. First Street, San Jose,
CA 95134, U.S.A.
TEL: 408-9436666
FAX: 408-5441798

Note: All data and specifications are subject to change without notice.