

# W78LE516/W78L516A Data Sheet



## Table of Contents-

1.	GENERAL DESCRIPTION .....	3
2.	FEATURES .....	3
3.	PIN CONFIGURATIONS .....	4
4.	PIN DESCRIPTION.....	6
5.	FUNCTIONAL DESCRIPTION .....	7
5.1	RAM .....	7
5.2	Timers 0, 1, and 2.....	7
5.3	Clock .....	8
5.4	Crystal Oscillator.....	8
5.5	External Clock.....	8
5.6	Power Management.....	8
5.7	Reduce EMI Emission .....	8
5.8	Reset.....	9
5.9	Port 4 .....	10
5.10	$\overline{\text{INT2}}/\overline{\text{INT3}}$ .....	10
5.11	Port 4 Base Address Registers .....	12
5.12	In-System Programming (ISP) Mode.....	14
5.13	In-System Programming Control Register (CHPCON).....	16
6.	SECURITY .....	20
6.1	Lock bit.....	20
6.2	MOVC Inhibit.....	20
6.3	Encryption .....	21
6.4	Oscillator Control .....	21
7.	ELECTRICAL CHARACTERISTICS.....	22
7.1	Absolute Maximum Ratings.....	22
7.2	D.C. Characteristics.....	22
7.3	A.C. Characteristics .....	24
8.	TIMING WAVEFORMS .....	26
8.1	Program Fetch Cycle .....	26
8.2	Data Read Cycle.....	26
8.3	Data Write Cycle.....	27
8.4	Port Access Cycle.....	27

## W78LE516/W78L516A



9.	TYPICAL APPLICATION CIRCUIT.....	28
9.1	External Program Memory and Crystal .....	28
9.2	Expanded External Data Memory and Oscillator .....	29
10.	PACKAGE DIMENSIONS.....	30
10.1	40-pin DIP .....	30
10.2	44-pin PLCC .....	30
10.3	44-pin PQFP .....	31
10.4	48-pin LQFP.....	31
11.	APPLICATION NOTE: IN-SYSTEM PROGRAMMING SOFTWARE EXAMPLES .....	32
12.	REVISION HISTORY .....	37

EEPW 电子产品世界  
.com.cn

# W78LE516/W78L516A



## 1. GENERAL DESCRIPTION

The W78L516 is an 8-bit microcontroller which has an in-system programmable Flash EPROM for firmware updating. The instruction set of the W78L516 is fully compatible with the standard 8052. The W78L516 contains a 64K bytes of main Flash EPROM and a 4K bytes of auxiliary Flash EPROM which allows the contents of the 64KB main Flash EPROM to be updated by the loader program located at the 4KB auxiliary Flash EPROM; 512 bytes of on-chip RAM; four 8-bit bi-directional and bit-addressable I/O ports; an additional 4-bit port P4; three 16-bit timer/counters; a serial port. These peripherals are supported by a eight sources two-level interrupt capability. To facilitate programming and verification, the Flash EPROM inside the W78L516 allows the program memory to be programmed and read electronically. Once the code is confirmed, the user can protect the code for security.

The W78L516 microcontroller has two power reduction modes, idle mode and power-down mode, both of which are software selectable. The idle mode turns off the processor clock but allows for continued peripheral operation. The power-down mode stops the crystal oscillator for minimum power consumption. The external clock can be stopped at any time and in any state without affecting the processor.

## 2. FEATURES

- Fully static design 8-bit CMOS microcontroller
- 64K bytes of in-system programmable Flash EPROM for Application Program (AP FLASH EPROM)
- 4K bytes of auxiliary Flash EPROM for Loader Program (LD FLASH EPROM)
- 512 bytes of on-chip RAM. (including 256 bytes of AUX-RAM, software selectable)
- 64K bytes program memory address space and 64K bytes data memory address space
- Four 8-bit bi-directional ports
- One 4-bit multipurpose programmable port
- Three 16-bit timer/counters
- One full duplex serial port
- Eight-sources, two-level interrupt capability
- Built-in power management
- Code protection
- Packaged in
  - Lead Free(RoHS) DIP 40: W78L516A24DL
  - Lead Free(RoHS) PLCC 44: W78L516A24PL
  - Lead Free(RoHS) QFP 44: W78L516A24FL
  - Lead Free(RoHS) LQFP 48: W78L516A24LL



# W78LE516/W78L516A



Pin Configurations, continued

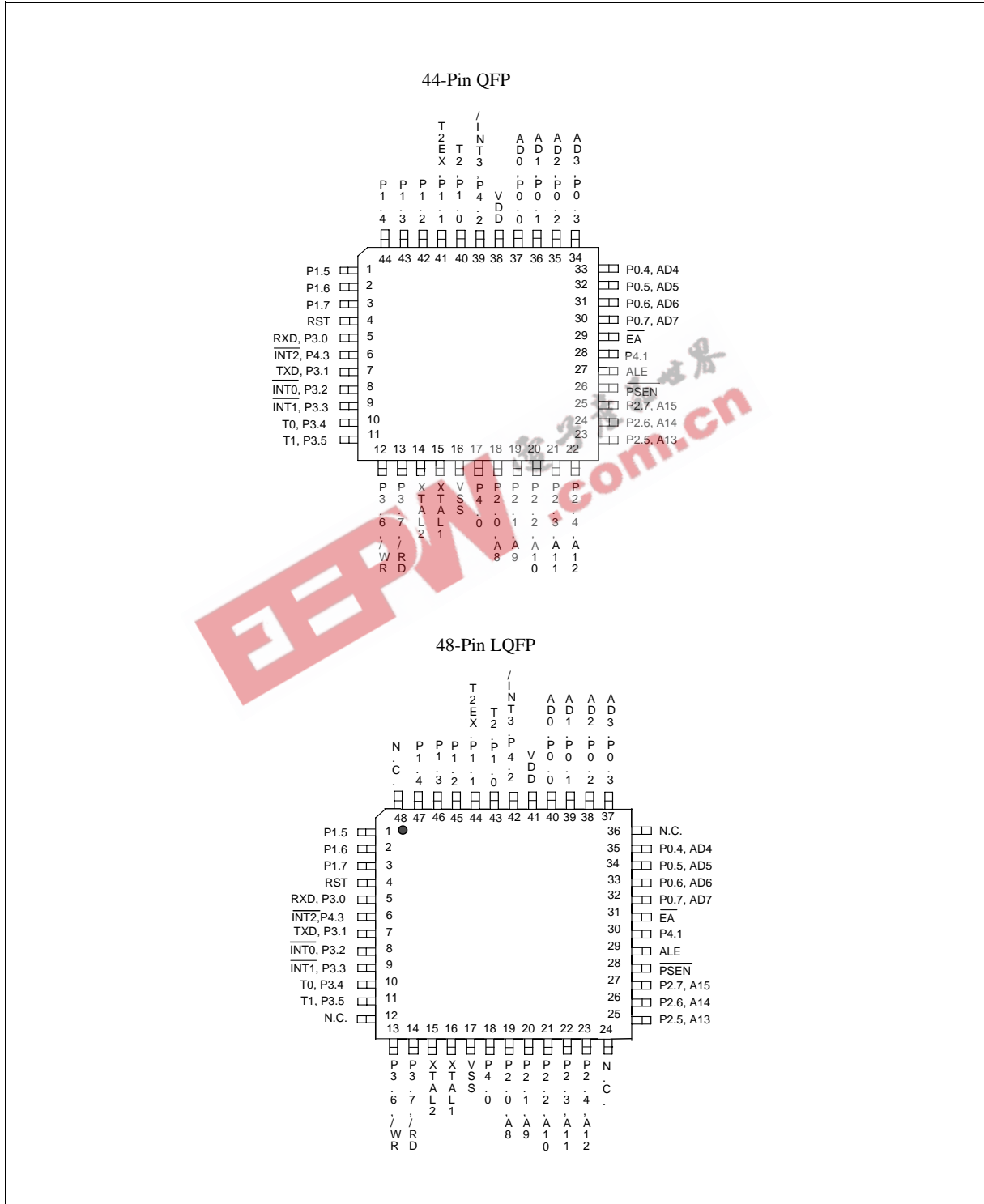

# W78LE516/W78L516A



## 4. PIN DESCRIPTION

SYMBOL	TYPE	DESCRIPTIONS
$\overline{EA}$	I	EXTERNAL ACCESS ENABLE: This pin forces the processor to execute the external ROM. The ROM address and data will not be presented on the bus if the $\overline{EA}$ pin is high.
$\overline{PSEN}$	O H	PROGRAM STORE ENABLE: $\overline{PSEN}$ enables the external ROM data in the Port 0 address/data bus. When internal ROM access is performed, no $\overline{PSEN}$ strobe signal outputs originate from this pin.
ALE	O H	ADDRESS LATCH ENABLE: ALE is used to enable the address latch that separates the address from the data on Port 0. ALE runs at 1/6th of the oscillator frequency.
RST	I L	RESET: A high on this pin for two machine cycles while the oscillator is running resets the device.
XTAL1	I	CRYSTAL 1: This is the crystal oscillator input. This pin may be driven by an external clock.
XTAL2	O	CRYSTAL 2: This is the crystal oscillator output. It is the inversion of XTAL1.
VSS	I	GROUND: ground potential.
VDD	I	POWER SUPPLY: Supply voltage for operation.
P0.0–P0.7	I/O D	PORT 0: Function is the same as that of standard 8052.
P1.0–P1.7	I/O H	PORT 1: Function is the same as that of standard 8052.
P2.0–P2.7	I/O H	PORT 2: Port 2 is a bi-directional I/O port with internal pull-ups. This port also provides the upper address bits for accesses to external memory.
P3.0–P3.7	I/O H	PORT 3: Function is the same as that of the standard 8052.
P4.0–P4.3	I/O H	PORT 4: A bi-directional I/O. See details below.

\* **Note:** TYPE I: input, O: output, I/O: bi-directional, H: pull-high, L: pull-low, D: open drain

### PORT4

Another bit-addressable port P4 is also available and only 4 bits (P4<3:0>) can be used. This port address is located at 0D8H with the same function as that of port P1,

Example:

```

P4      REG 0D8H
MOV     P4, #0AH      ; Output data "A" through P4.0–P4.3.
MOV     A, P4         ; Read P4 status to Accumulator.
ORL     P4, #0000001B ; Set bit P4.0
ANL     P4, #11111101B ; Clear bit P4.1
    
```

# W78LE516/W78L516A



## 5. FUNCTIONAL DESCRIPTION

The W78L516 architecture consists of a core controller surrounded by various registers, four general purpose I/O ports, one special purpose programmable 4-bits I/O port, 512 bytes of RAM, three timer/counters, a serial port. The processor supports 111 different opcodes and references both a 64K program address space and a 64K data storage space.

### 5.1 RAM

The internal data RAM in the W78L516 is 512 bytes. It is divided into two banks: 256 bytes of scratchpad RAM and 256 bytes of AUX-RAM. These RAMs are addressed by different ways.

- RAM 0H–7FH can be addressed directly and indirectly as the same as in 8051. Address pointers are R0 and R1 of the selected register bank.
- RAM 80H–FFH can only be addressed indirectly as the same as in 8051. Address pointers are R0, R1 of the selected registers bank.
- AUX-RAM 0H–FFH is addressed indirectly as the same way to access external data memory with the MOVX instruction. Address pointers are R0 and R1 of the selected register bank and DPTR register. An access to external data memory locations higher than FFH will be performed with the MOVX instruction in the same way as in the 8051. The AUX-RAM is disabled after a reset. Setting the bit 4 in CHPCON register will enable the access to AUX-RAM. When AUX-RAM is enabled the instructions of "MOVX @Ri" will always access to on-chip AUX-RAM. When executing from internal program memory, an access to AUX-RAM will not affect the Ports P0, P2,  $\overline{WR}$  and  $\overline{RD}$ .

Example,

```
CHPENR    REG    F6H
CHPCON    REG    BFH
MOV       CHPENR, #87H
MOV       CHPENR, #59H
ORL       CHPCON, #00010000B ; enable AUX-RAM
MOV       CHPENR, #00H
MOV       R0, #12H
MOV       A, #34H
MOVX     @R0, A ; Write 34h data to 12h address.
```

### 5.2 Timers 0, 1, and 2

Timers 0, 1, and 2 each consist of two 8-bit data registers. These are called TL0 and TH0 for Timer 0, TL1 and TH1 for Timer 1, and TL2 and TH2 for Timer 2. The TCON and TMOD registers provide control functions for timers 0, 1. The T2CON register provides control functions for Timer 2. RCAP2H and RCAP2L are used as reload/capture registers for Timer 2. The operations of Timer 0 and Timer 1 are the same as in the W78C51. Timer 2 is a 16-bit timer/counter that is configured and controlled by the T2CON register. Like Timers 0 and 1, Timer 2 can operate as either an external event counter or as an internal timer, depending on the setting of bit C/T2 in T2CON. Timer 2 has three operating modes: capture, auto-reload, and baud rate generator. The clock speed at capture or auto-reload mode is the same as that of Timers 0 and 1.

## W78LE516/W78L516A



### 5.3 Clock

The W78L516 is designed with either a crystal oscillator or an external clock. Internally, the clock is divided by two before it is used by default. This makes the W78L516 relatively insensitive to duty cycle variations in the clock.

### 5.4 Crystal Oscillator

The W78L516 incorporates a built-in crystal oscillator. To make the oscillator work, a crystal must be connected across pins XTAL1 and XTAL2. In addition, a load capacitor must be connected from each pin to ground.

### 5.5 External Clock

An external clock should be connected to pin XTAL1. Pin XTAL2 should be left unconnected. The XTAL1 input is a CMOS-type input, as required by the crystal oscillator.

### 5.6 Power Management

#### Idle Mode

Setting the IDL bit in the PCON register enters the idle mode. In the idle mode, the internal clock to the processor is stopped. The peripherals and the interrupt logic continue to be clocked. The processor will exit idle mode when either an interrupt or a reset occurs.

#### Power-down Mode

When the PD bit in the PCON register is set, the processor enters the power-down mode. In this mode all of the clocks are stopped, including the oscillator. To exit from power-down mode is by a hardware reset or external interrupts  $\overline{INT0}$  to  $\overline{INT1}$  when enabled and set to level triggered.

### 5.7 Reduce EMI Emission

The W78L516 allows user to diminish the gain of on-chip oscillator amplifier by using programmer to clear the B7 bit of security register. Once B7 is set to 0, a half of gain will be decreased. Care must be taken if user attempts to diminish the gain of oscillator amplifier, reducing a half of gain may affect the external crystal operating improperly at high frequency. The value of C1 and C2 may need some adjustment while running at lower gain.



# W78LE516/W78L516A



## 5.8 Reset

The external RESET signal is sampled at S5P2. To take effect, it must be held high for at least two machine cycles while the oscillator is running. An internal trigger circuit in the reset line is used to deglitch the reset line when the W78L516 is used with an external RC network. The reset logic also has a special glitch removal circuit that ignores glitches on the reset line. During reset, the ports are initialized to FFH, the stack pointer to 07H, PCON (with the exception of bit 4) to 00H, and all of the other SFR registers except SBUF to 00H. SBUF is not reset.

### W78L516 Special Function Registers (SFRs) and Reset Values

F8									FF
F0	+B 00000000						CHPENR 00000000		F7
E8									EF
E0	+ACC 00000000								E7
D8	+P4 xxxx1111								DF
D0	+PSW 00000000								D7
C8	+T2CON 00000000		RCAP2L 00000000	RCAP2H 00000000	TL2 00000000	TH2 00000000			CF
C0	XICON 00000000		<b>P4CONA</b> 00000000	<b>P4CONB</b> 00000000	<b>SFRAL</b> 00000000	<b>SFRAH</b> 00000000	<b>SFRFD</b> 00000000	<b>SFRCN</b> 00000000	C7
B8	+IP 00000000							CHPCON 0xx00000	BF
B0	+P3 00000000				<b>P43AL</b> 00000000	<b>P43AH</b> 00000000			B7
A8	+IE 00000000				<b>P42AL</b> 00000000	<b>P42AH</b> 00000000	<b>P2ECON</b> 0000xx00		AF
A0	+P2 11111111								A7
98	+SCON 00000000	SBUF xxxxxxx							9F
90	+P1 11111111				<b>P41AL</b> 00000000	<b>P41AH</b> 00000000			97
88	+TCON 00000000	TMOD 00000000	TL0 00000000	TL1 00000000	TH0 00000000	TH1 00000000			8F
80	+P0 11111111	SP 00000111	DPL 00000000	DPH 00000000	<b>P40AL</b> 00000000	<b>P40AH</b> 00000000		PCON 00110000	87

#### Notes:

1. The SFRs marked with a plus sign(+) are both byte- and bit-addressable.
2. The text of SFR with bold type characters are extension function registers.



**5.9 Port 4**

Port 4, address D8H, is a 4-bit multipurpose programmable I/O port. Each bit can be configured individually by software. The Port 4 has four different operation modes.

Mode 0: P4.0–P4.3 is a bi-directional I/O port which is same as port 1. P4.2 and P4.3 also serve as external interrupt  $\overline{\text{CLR}}$  and  $\overline{\text{INT2}}$  if enabled.

Mode 1: P4.0–P4.3 are read strobe signals that are synchronized with  $\overline{\text{RD}}$  signal at specified addresses. These signals can be used as chip-select signals for external peripherals.

Mode 2: P4.0–P4.3 are write strobe signals that are synchronized with  $\overline{\text{WR}}$  signal at specified addresses. These signals can be used as chip-select signals for external peripherals.

Mode 3: P4.0–P4.3 are read/write strobe signals that are synchronized with  $\overline{\text{RD}}$  or  $\overline{\text{WR}}$  signal at specified addresses. These signals can be used as chip-select signals for external peripherals.

When Port 4 is configured with the feature of chip-select signals, the chip-select signal address range depends on the contents of the SFR P4xAH, P4xAL, P4CONA and P4CONB. The registers P4xAH and P4xAL contain the 16-bit base address of P4.x. The registers P4CONA and P4CONB contain the control bits to configure the Port 4 operation mode.

**5.10  $\overline{\text{INT2}}/\overline{\text{INT3}}$**

Two additional external interrupts,  $\overline{\text{INT2}}$  and  $\overline{\text{INT3}}$ , whose functions are similar to those of external interrupt 0 and 1 in the standard 80C52. The functions/status of these interrupts are determined/shown by the bits in the XICON (External Interrupt Control) register. The XICON register is bit-addressable but is not a standard register in the standard 80C52. Its address is at 0C0H. To set/clear bits in the XICON register, one can use the "SETB ( $\overline{\text{CLR}}$ ) bit" instruction. For example, "SETB 0C2H" sets the EX2 bit of XICON.

**XICON - external interrupt control (C0H)**

PX3	EX3	IE3	IT3	PX2	EX2	IE2	IT2
-----	-----	-----	-----	-----	-----	-----	-----

PX3: External interrupt 3 priority high if set

EX3: External interrupt 3 enable if set

IE3: If IT3 = 1, IE3 is set/cleared automatically by hardware when interrupt is detected/serviced

IT3: External interrupt 3 is falling-edge/low-level triggered when this bit is set/cleared by software

PX2: External interrupt 2 priority high if set

EX2: External interrupt 2 enable if set

IE2: If IT2 = 1, IE2 is set/cleared automatically by hardware when interrupt is detected/serviced

IT2: External interrupt 2 is falling-edge/low-level triggered when this bit is set/cleared by software

## W78LE516/W78L516A



### Eight-source interrupt information:

INTERRUPT SOURCE	VECTOR ADDRESS	POLLING SEQUENCE WITHIN PRIORITY LEVEL	ENABLE REQUIRED SETTINGS	INTERRUPT TYPE EDGE/LEVEL
External Interrupt 0	03H	0 (highest)	IE.0	TCON.0
Timer/Counter 0	0BH	1	IE.1	-
External Interrupt 1	13H	2	IE.2	TCON.2
Timer/Counter 1	1BH	3	IE.3	-
Serial Port	23H	4	IE.4	-
Timer/Counter 2	2BH	5	IE.5	-
External Interrupt 2	33H	6	XICON.2	XICON.0
External Interrupt 3	3BH	7 (lowest)	XICON.6	XICON.3

### P4CONB (C3H)

BIT	NAME	FUNCTION
7, 6	P43FUN1 P43FUN0	00: Mode 0. P4.3 is a general purpose I/O port which is the same as Port1. 01: Mode 1. P4.3 is a Read Strobe signal for chip select purpose. The address range depends on the SFR P43AH, P43AL, P43CMP1 and P43CMP0. 10: Mode 2. P4.3 is a Write Strobe signal for chip select purpose. The address range depends on the SFR P43AH, P43AL, P43CMP1 and P43CMP0. 11: Mode 3. P4.3 is a Read/Write Strobe signal for chip select purpose. The address range depends on the SFR P43AH, P43AL, P43CMP1, and P43CMP0.
5, 4	P43CMP1 P43CMP0	Chip-select signals address comparison: 00: Compare the full address (16 bits length) with the base address register P43AH, P43AL. 01: Compare the 15 high bits (A15–A1) of address bus with the base address register P43AH, P43AL. 10: Compare the 14 high bits (A15–A2) of address bus with the base address register P43AH, P43AL. 11: Compare the 8 high bits (A15–A8) of address bus with the base address register P43AH, P43AL.
3, 2	P42FUN1 P42FUN0	The P4.2 function control bits which are the similar definition as P43FUN1, P43FUN0.
1, 0	P42CMP1 P42CMP0	The P4.2 address comparator length control bits which are the similar definition as P43CMP1, P43CMP0.

## W78LE516/W78L516A



### P4CONA (C2H)

BIT	NAME	FUNCTION
7, 6	P41FUN1 P41FUN0	The P4.1 function control bits which are the similar definition as P43FUN1, P43FUN0.
5, 4	P41CMP1 P41CMP0	The P4.1 address comparator length control bits which are the similar definition as P43CMP1, P43CMP0.
3, 2	P40FUN1 P40FUN0	The P4.0 function control bits which are the similar definition as P43FUN1, P43FUN0.
1, 0	P40CMP1 P40CMP0	The P4.0 address comparator length control bits which are the similar definition as P43CMP1, P43CMP0.

### P2ECON (AEH)

BIT	NAME	FUNCTION
7	P43CSINV	The active polarity of P4.3 when pin P4.3 is defined as read and/or write strobe signal. = 1: P4.3 is active high when pin P4.3 is defined as read and/or write strobe signal. = 0: P4.3 is active low when pin P4.3 is defined as read and/or write strobe signal.
6	P42CSINV	The similarity definition as P43SINV.
5	P41CSINV	The similarity definition as P43SINV.
4	P40CSINV	The similarity definition as P43SINV.
3	-	Reserve
2	-	Reserve
1	-	0
0	-	0

### 5.11 Port 4 Base Address Registers

#### P40AH, P40AL:

The Base address register for comparator of P4.0. P40AH contains the high-order byte of address, P40AL contains the low-order byte of address.

#### P41AH, P41AL:

The Base address register for comparator of P4.1. P41AH contains the high-order byte of address, P41AL contains the low-order byte of address.

## W78LE516/W78L516A



### P42AH, P42AL:

The Base address register for comparator of P4.2. P42AH contains the high-order byte of address, P42AL contains the low-order byte of address.

### P43AH, P43AL:

The Base address register for comparator of P4.3. P43AH contains the high-order byte of address, P43AL contains the low-order byte of address.

### P4 (D8H)

BIT	NAME	FUNCTION
7	-	Reserve
6	-	Reserve
5	-	Reserve
4	-	Reserve
3	P43	Port 4 Data bit which outputs to pin P4.3 at mode 0.
2	P42	Port 4 Data bit which outputs to pin P4.2 at mode 0.
1	P41	Port 4 Data bit which outputs to pin P4.1 at mode 0.
0	P40	Port 4 Data bit which outputs to pin P4.0 at mode 0.

Here is an example to program the P4.0 as a write strobe signal at the I/O port address 1234H–1237H and positive polarity, and P4.1–P4.3 are used as general I/O ports.

```
MOV P40AH,#12H
MOV P40AL,#34H          ; Base I/O address 1234H for P4.0
MOV P4CONA,#00001010B  ; P4.0 a write strobe signal and address line A0 and A1 are masked.
MOV P4CONB,#00H        ; P4.1–P4.3 as general I/O port which are the same as PORT1
MOV P2ECON,#10H        ; Write the P40SINV = 1 to inverse the P4.0 write strobe polarity
                        ; default is negative.
```

Then any instruction MOVX @DPTR,A (with DPTR = 1234H–1237H) will generate the positive polarity write strobe signal at pin P4.0. And the instruction MOV P4, #XX will output the bit3 to bit1 of data #XX to pin P4.3–P4.1.

## W78LE516/W78L516A

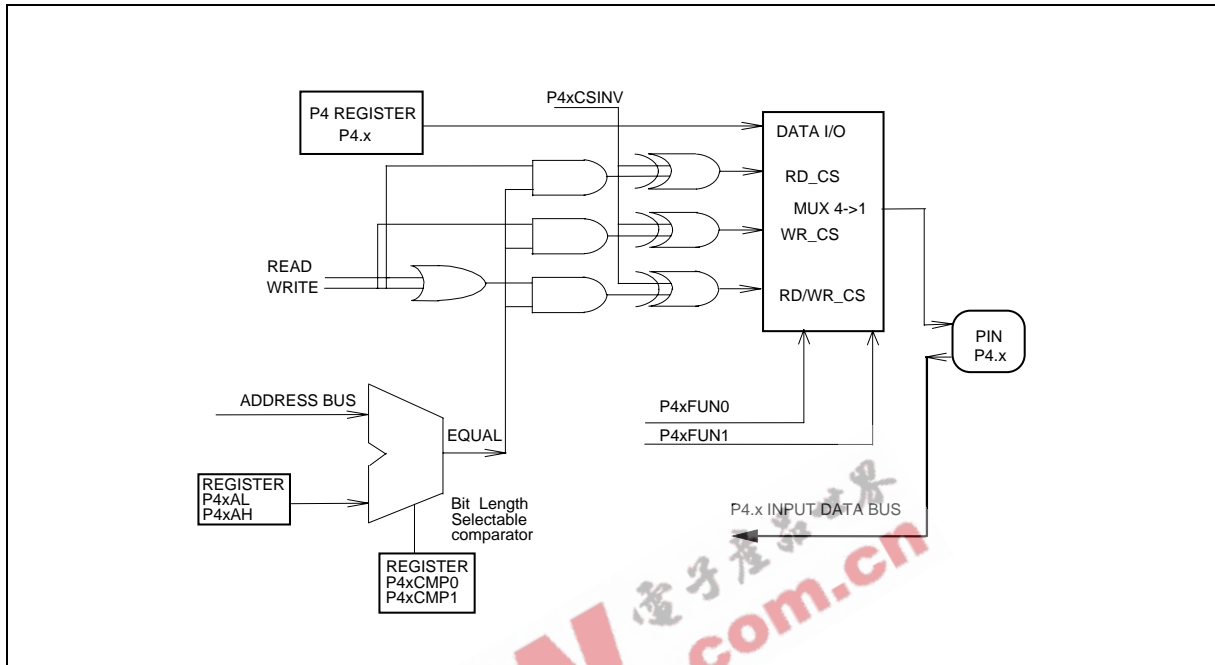

### 5.12 In-System Programming (ISP) Mode

The W78L516 equips one 64K byte of main Flash EPROM bank for application program (called AP FLASH EPROM) and one 4K byte of auxiliary Flash EPROM bank for loader program (called LD FLASH EPROM). In the normal operation, the microcontroller executes the code in the AP FLASH EPROM. If the content of AP FLASH EPROM needs to be modified, the W78L516 allows user to activate the In-System Programming (ISP) mode by setting the CHPCON register. **The CHPCON is read-only by default, software must write two specific values 87H, then 59H sequentially to the CHPENR register to enable the CHPCON write attribute. Writing CHPENR register with the values except 87H and 59H will close CHPCON register write attribute.** The W78L516 achieves all in-system programming operations including enter/exit ISP Mode, program, erase, read ... etc, during device in the idle mode. Setting the bit CHPCON.0 the device will enter in-system programming mode after a wake-up from idle mode. Because device needs proper time to complete the ISP operations before awoken from idle mode, software may use timer interrupt to control the duration for device wake-up from idle mode. To perform ISP operation for revising contents of AP FLASH EPROM, software located at AP FLASH EPROM setting the CHPCON register then enter idle mode, after awoken from idle mode the device executes the corresponding interrupt service routine in LD FLASH EPROM. Because the device will clear the program counter while switching from AP FLASH EPROM to LD FLASH EPROM, the first execution of RETI instruction in interrupt service routine will jump to 00H at LD FLASH EPROM area. The device offers a software reset for switching back to AP FLASH EPROM while the content of AP FLASH EPROM has been updated completely. **Setting CHPCON register bit 0, 1 and 7 to logic-1 will result a software reset to reset the CPU.** The software reset serves as a external reset. This in-system programming feature makes the job easy and efficient in which the application needs to update firmware frequently. In some applications, the in-system programming feature make it possible to easily update the system firmware without opening the chassis.

**Note:** The ISP Mode operates by supply voltage from 3.3V to 5.5V.

## W78LE516/W78L516A



**SFRAH, SFRAL:** The objective address of on-chip Flash EPROM in the in-system programming mode. SFRAH contains the high-order byte of address, SFRAL contains the low-order byte of address.

**SFRFD:** The programming data for on-chip Flash EPROM in programming mode.

**SFRCN:** The control byte of on-chip Flash EPROM programming mode.

### SFRCN (C7)

BIT	NAME	FUNCTION
7	-	Reserve.
6	WFWIN	On-chip Flash EPROM bank select for in-system programming. = 0: 64K bytes Flash EPROM bank is selected as destination for re-programming. = 1: 4K bytes Flash EPROM bank is selected as destination for re-programming.
5	OEN	Flash EPROM output enable.
4	CEN	Flash EPROM chip enable.
3, 2, 1, 0	CTRL[3:0]	The flash control signals

MODE	WFWIN	CTRL<3:0>	OEN	CEN	SFRAH, SFRAL	SFRFD
Erase 64KB AP FLASH EPROM	0	0010	1	0	X	X
Program 64KB AP FLASH EPROM	0	0001	1	0	Address in	Data in
Read 64KB AP FLASH EPROM	0	0000	0	0	Address in	Data out
Erase 4KB LD FLASH EPROM	1	0010	1	0	X	X
Program 4KB LD FLASH EPROM	1	0001	1	0	Address in	Data in
Read 4KB LD FLASH EPROM	1	0000	0	0	Address in	Data out

## W78LE516/W78L516A



### 5.13 In-System Programming Control Register (CHPCON)

#### CHPCON (BFH)

BIT	NAME	FUNCTION
7	SWRESET (F04KMODE)	When this bit is set to 1, and both FBOOTSL and FPROGEN are set to 1. It will enforce microcontroller reset to initial condition just like power on reset. This action will re-boot the microcontroller and start to normal operation. To read this bit in logic-1 can determine that the H/W REBOOT mode is running.
6	-	Reserve.
5	-	Reserve.
4	ENAUSTRAM	1: Enable on-chip AUX-RAM. 0: Disable the on-chip AUX-RAM
3	0	Must set to 0.
2	0	Must set to 0.
1	FBOOTSL	The Program Location Select. 0: The Loader Program locates at the 64 KB AP FLASH EPROM. 4KB LD FLASH EPROM is destination for re-programming. 1: The Loader Program locates at the 4 KB memory bank. 64KB AP FLASH EPROM is destination for re-programming.
0	FPROGEN	FLASH EPROM Programming Enable. = 1: enable. The microcontroller enter the in-system programming mode after entering the idle mode and wake-up from interrupt. During in-system programming mode, the operation of erase, program and read are achieve when device enters idle mode. = 0: disable. The on-chip flash memory is read-only. In-system programmability is disabled.

#### H/W REBOOT Mode (Boot from LD FLASH EPROM)

By default, the W78L516 boots from AP FLASH EPROM program after a power on reset. On some occasions, user can force the W78L516 to boot from the LD FLASH EPROM program via following settings. The possible situation that you need to enter H/W REBOOT mode when the AP FLASH EPROM program can not run properly and device can not jump back to LD FLASH EPROM to execute in-system programming function. Then you can use this H/W REBOOT mode to force the W78L516 jumps to LD FLASH EPROM and executes in-system programming procedure. When you design your system, you may reserve the pins P2.6, P2.7 to switches or jumpers. For example in a CD-ROM system, you can connect the P2.6 and P2.7 to PLAY and EJECT buttons on the panel. When the AP FLASH EPROM program fails to execute the normal application program. User can press both two buttons at the same time and then turn on the power of the personal computer to force the W78L516 to enter the H/W REBOOT mode. After power on of personal computer, you can release both buttons and finish the in-system programming procedure to update the AP FLASH EPROM code. In application system design, user must take care of the P2, P3, ALE,  $\overline{EA}$  and  $\overline{PSEN}$  pin value at reset to prevent from accidentally activating the programming mode or H/W REBOOT mode.



# W78LE516/W78L516A



## H/W REBOOT MODE

P4.3	P2.7	P2.6	MODE
X	L	L	FO4KBOOT
L	X	X	FO4KBOOT

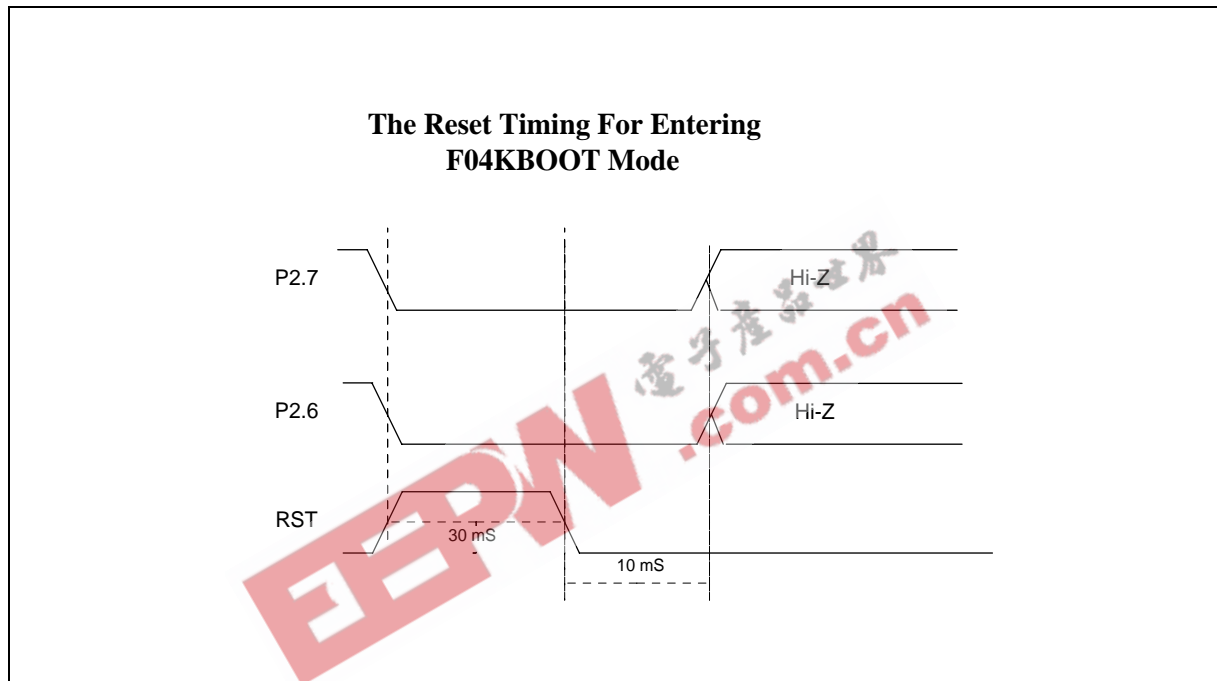



The Algorithm of In-System Programming

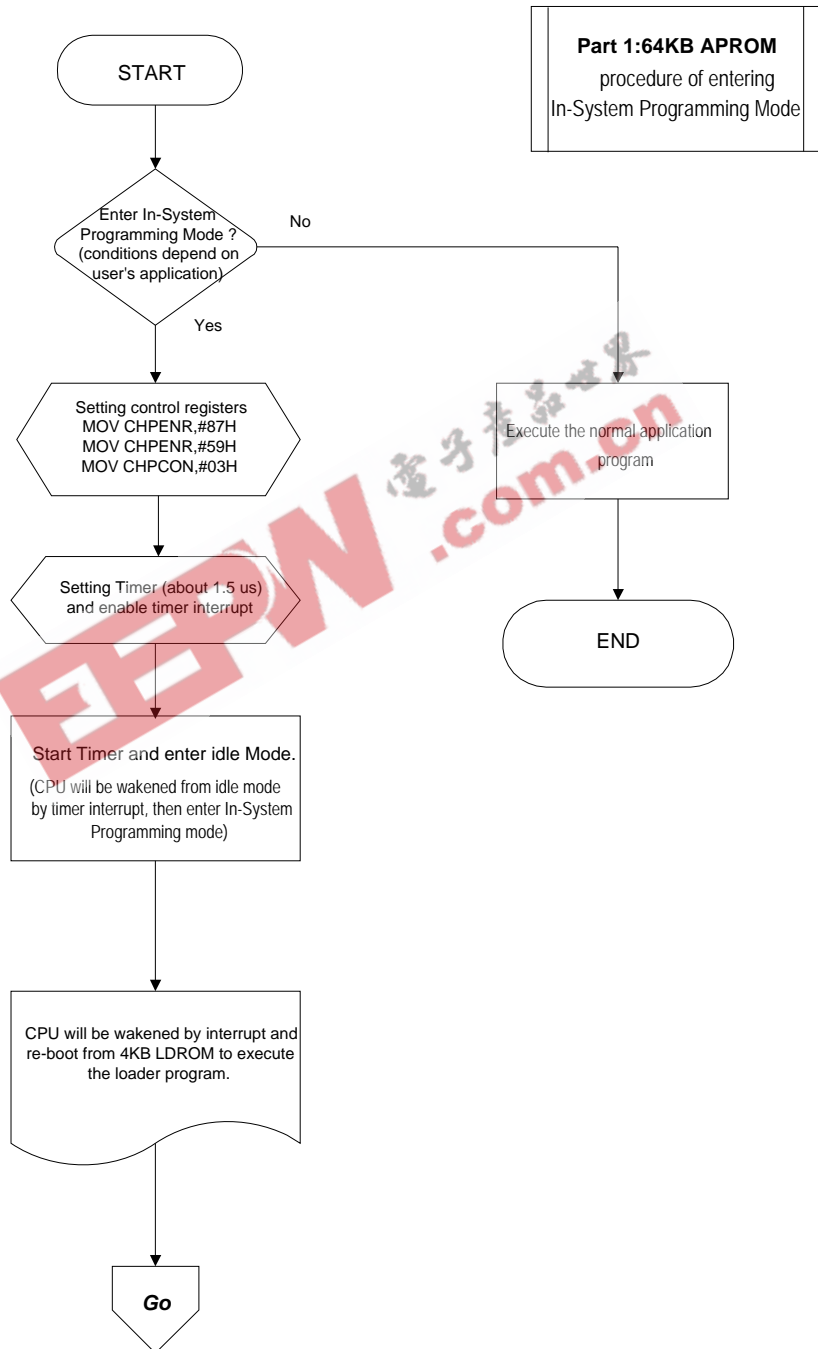

# W78LE516/W78L516A



**Part 2: 4KB LDROM**  
 Procedure of Updating  
 the 64KB APROM

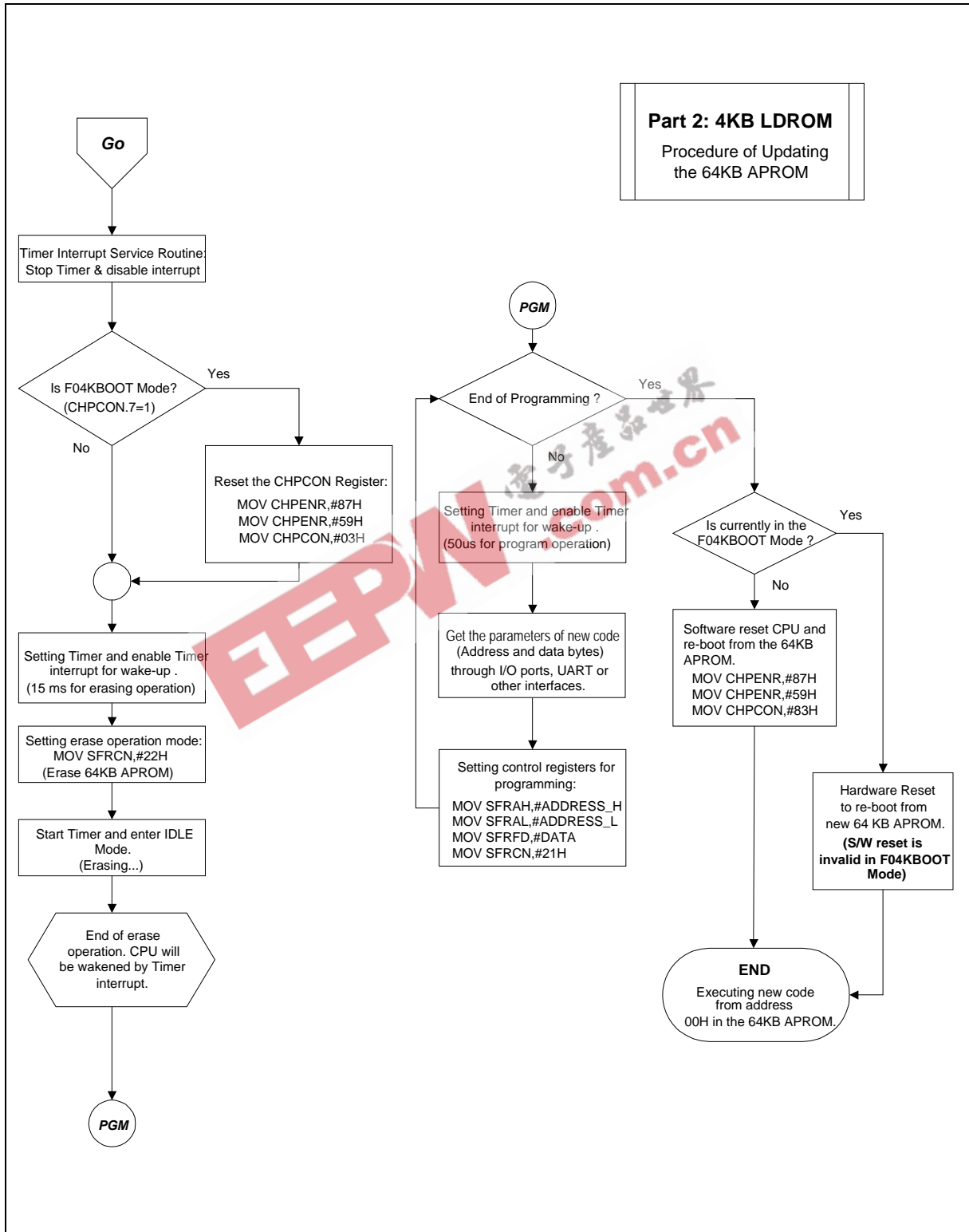

# W78LE516/W78L516A



## 6. SECURITY

During the on-chip ROM programming mode, the Flash EPROM can be programmed and verified repeatedly. Until the code inside the ROM is confirmed OK, the code can be protected. The protection of ROM and those operations on it are described below.

The W78L516 has a Security Register which can not be accessed in programming mode. Those bits of the Security Registers can not be changed once they have been programmed from high to low. They can only be reset through erase-all operation. The Security Register is located at the 0FFFFH of the LD FLASH EPROM space.

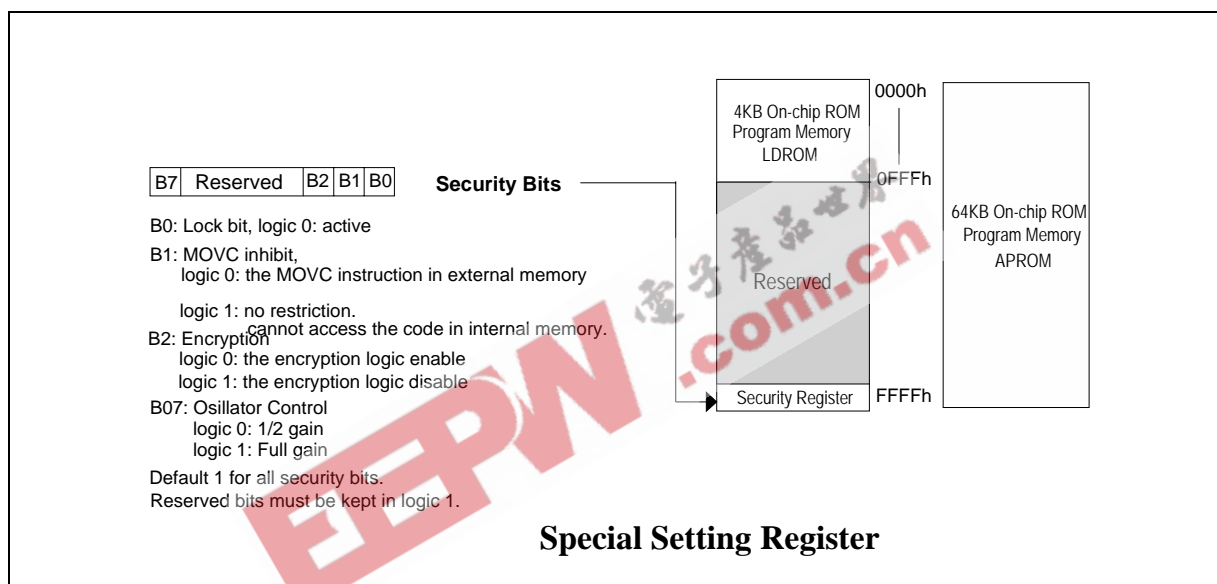

### 6.1 Lock bit

This bit is used to protect the customer's program code in the W78L516. It may be set after the programmer finishes the programming and verifies sequence. Once this bit is set to logic 0, both the FLASH EPROM data and Special Setting Register can be accessed again.

### 6.2 MOVC Inhibit

This bit is used to restrict the accessible region of the MOVC instruction. It can prevent the MOVC instruction in external program memory from reading the internal program code. When this bit is set to logic 0, a MOVC instruction in external program memory space will be able to access code only in the external memory, not in the internal memory. A MOVC instruction in internal program memory space will always be able to access the FLASH EPROM data in both internal and external memory. If this bit is logic 1, there are no restrictions on the MOVC instruction.

## W78LE516/W78L516A



### 6.3 Encryption

This bit is used to enable/disable the encryption logic for code protection. Once encryption feature is enabled, the data presented on port 0 will be encoded via encryption logic. Only whole chip erase will reset this bit.

### 6.4 Oscillator Control

W78L516 allow user to diminish the gain of on-chip oscillator amplifier by using programmer to set the bit B7 of security register. Once B7 is set to 0, a half of gain will be decreased. Care must be taken if user attempts to diminish the gain of oscillator amplifier, reducing a half of gain may improperly affect the external crystal operation at high frequency. The value of C1 and C2 may need some adjustment while running at lower gain.



# W78LE516/W78L516A



## 7. ELECTRICAL CHARACTERISTICS

### 7.1 Absolute Maximum Ratings

PARAMETER	SYMBOL	MIN.	MAX.	UNIT
DC Power Supply	VDD-VSS	-0.3	+6.0	V
Input Voltage	VIN	VSS -0.3	VDD +0.3	V
Operating Temperature	TA	0	60	°C
Storage Temperature	TST	-55	+150	°C

**Note:** Exposure to conditions beyond those listed under Absolute Maximum Ratings may adversely affect the life and reliability of the device.

### 7.2 D.C. Characteristics

VSS = 0V, TA = 25° C, unless otherwise specified.

PARAMETER	SYM.	SPECIFICATION		UNIT	TEST CONDITIONS
		MIN.	MAX.		
Operating Voltage	VDD	2.4	5.5	V	Without I.S.P.
		3.3	5.5	V	With I.S.P.
Operating Current	IDD	-	20	mA	No load VDD = 5.5V
		-	3	mA	No load VDD = 2.4V
Idle Current	IIDLE	-	6	mA	VDD = 5.5V, Fosc = 20 MHz
		-	1.5	mA	VDD = 2.4V, Fosc = 12 MHz
Power Down Current	IPWDN	-	50	μA	VDD = 5.5V, Fosc = 20 MHz
		-	20	μA	VDD = 2.4V, Fosc = 12 MHz
Input Current P1, P2, P3, P4	IIN1	-50	+10	μA	VDD = 5.5V VIN = 0V or VDD
Input Current RST	IIN2	-10	+300	μA	VDD = 5.5V 0 < VIN < VDD
Input Leakage Current P0, EA	ILK	-10	+10	μA	VDD = 5.5V 0V < VIN < VDD
Logic 1 to 0 Transition Current P1, P2, P3, P4	ITL [*4]	-500	-	μA	VDD = 5.5V VIN = 2.0V
Input Low Voltage P0, P1, P2, P3, P4, EA	VIL1	0	0.8	V	VDD = 4.5V
		0	0.5	V	VDD = 2.4V

# W78LE516/W78L516A



D.C. Characteristics, continued

PARAMETER	SYM.	SPECIFICATION		UNIT	TEST CONDITIONS
		MIN.	MAX.		
Input Low Voltage RST[*1]	VIL2	0	0.8	V	VDD = 4.5V
		0	0.3	V	VDD = 2.4V
Input Low Voltage XTAL1 [*3]	VIL3	0	0.8	V	VDD = 4.5V
		0	0.4	V	VDD = 2.4V
Input High Voltage P0, P1, P2, P3, P4, $\overline{EA}$	VIH1	2.4	VDD + 0.2	V	VDD = 5.5V
		1.4	VDD + 0.2	V	VDD = 2.4V
Input High Voltage RST[*1]	VIH2	3.5	VDD + 0.2	V	VDD = 5.5V
		1.7	VDD + 0.2	V	VDD = 2.4V
Input High Voltage XTAL1 [*3]	VIH3	3.5	VDD + 0.2	V	VDD = 5.5V
		2.4	VDD + 0.2	V	VDD = 2.4V
Output Low Voltage P1, P2, P3, P4	VOL1	-	0.45	V	VDD = 4.5V, IOL = +2 mA
		-	0.25	V	VDD = 2.4V, IOL = +1 mA
Output Low Voltage P0, ALE, $\overline{PSEN}$ [*2]	VOL2	-	0.45	V	VDD = 4.5V, IOL = +4 mA
		-	0.25	V	VDD = 2.4V, IOL = +2 mA
Sink Current P1, P2, P3, P4	ISK1	4	12	mA	VDD = 4.5V, Vin = 0.45V
		1.8	5.4	mA	VDD = 2.4V, Vin = 0.45V
Sink Current P0, ALE, $\overline{PSEN}$	ISK2	8	16	mA	VDD = 4.5V, Vin = 0.45V
		4.5	9	mA	VDD = 2.4V, Vin = 0.4V
Output High Voltage P1, P2, P3, P4	VOH1	2.4	-	V	VDD = 4.5V, IOH = -100 $\mu$ A
		1.4	-	V	VDD = 2.4V, IOH = -8 $\mu$ A
Output High Voltage P0, ALE, $\overline{PSEN}$ [*2]	VOH2	2.4	-	V	VDD = 4.5V, IOH = -400 $\mu$ A
		1.4	-	V	VDD = 2.4V, IOH = -200 $\mu$ A
Source Current P1, P2, P3, P4	ISR1	-100	-250	$\mu$ A	VDD = 4.5V, Vin = 2.4V
		-20	-50	$\mu$ A	VDD = 2.4V, Vin = 1.4V
Source Current P0, ALE, $\overline{PSEN}$	ISR2	-8	-14	mA	VDD = 4.5V, Vin = 2.4V
		-1.9	-3.8	mA	VDD = 2.4V, Vin = 1.4V

**Notes:**

- \*1. RST pin is a Schmitt trigger input.
- \*2. P0, ALE and  $\overline{PSEN}$  are tested in the external access mode.
- \*3. XTAL1 is a CMOS input.
- \*4. Pins of P1, P2, P3, P4 can source a transition current when they are being externally driven from 1 to 0.

## W78LE516/W78L516A



### 7.3 A.C. Characteristics

The AC specifications are a function of the particular process used to manufacture the part, the ratings of the I/O buffers, the capacitive load, and the internal routing capacitance. Most of the specifications can be expressed in terms of multiple input clock periods (TCP), and actual parts will usually experience less than a  $\pm 20$  nS variation. The numbers below represent the performance expected from a 0.6 micron CMOS process when using 2 and 4 mA output buffers.

#### Clock Input Waveform

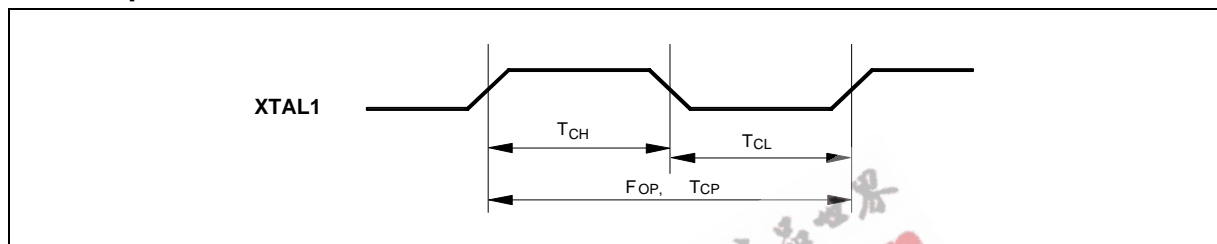

PARAMETER	SYMBOL	MIN.	TYP.	MAX.	UNIT	NOTES
Operating Speed	FOP	0	-	20	MHz	1
Clock Period	TCP	50	-	-	nS	2
Clock High	TCH	25	-	-	nS	3
Clock Low	TCL	25	-	-	nS	3

#### Notes:

1. The clock may be stopped indefinitely in either state.
2. The TCP specification is used as a reference in other specifications.
3. There are no duty cycle requirements on the XTAL1 input.

#### Program Fetch Cycle

PARAMETER	SYMBOL	MIN.	TYP.	MAX.	UNIT	NOTES
Address Valid to ALE Low	TAAS	1 TCP- $\Delta$	-	-	nS	4
Address Hold from ALE Low	TAAH	1 TCP- $\Delta$	-	-	nS	1, 4
ALE Low to $\overline{\text{PSEN}}$ Low	TAPL	1 TCP- $\Delta$	-	-	nS	4
$\overline{\text{PSEN}}$ Low to Data Valid	TPDA	-	-	2 TCP	nS	2
Data Hold after $\overline{\text{PSEN}}$ High	TPDH	0	-	1 TCP	nS	3
Data Float after $\overline{\text{PSEN}}$ High	TPDZ	0	-	1 TCP	nS	
ALE Pulse Width	TALW	2 TCP- $\Delta$	2 TCP	-	nS	4
$\overline{\text{PSEN}}$ Pulse Width	TPSW	3 TCP- $\Delta$	3 TCP	-	nS	4

#### Notes:

1. P0.0–P0.7, P2.0–P2.7 remain stable throughout entire memory cycle.
2. Memory access time is 3 TCP.
3. Data have been latched internally prior to  $\overline{\text{PSEN}}$  going high.
4. " $\Delta$ " (due to buffer driving delay and wire loading) is 20 nS.



# W78LE516/W78L516A



## Data Read Cycle

PARAMETER	SYMBOL	MIN.	TYP.	MAX.	UNIT	NOTES
ALE Low to $\overline{RD}$ Low	TDAR	3 TCP- $\Delta$	-	3 TCP+ $\Delta$	nS	1, 2
$\overline{RD}$ Low to Data Valid	TDDA	-	-	4 TCP	nS	1
Data Hold from $\overline{RD}$ High	TDDH	0	-	2 TCP	nS	
Data Float from $\overline{RD}$ High	TDDZ	0	-	2 TCP	nS	
$\overline{RD}$ Pulse Width	TDRD	6 TCP- $\Delta$	6 TCP	-	nS	2

### Notes:

1. Data memory access time is 8 TCP.
2. " $\Delta$ " (due to buffer driving delay and wire loading) is 20 nS.

## Data Write Cycle

PARAMETER	SYMBOL	MIN.	TYP.	MAX.	UNIT
ALE Low to $\overline{WR}$ Low	TDAW	3 TCP- $\Delta$	-	3 TCP+ $\Delta$	nS
Data Valid to $\overline{WR}$ Low	TDAD	1 TCP- $\Delta$	-	-	nS
Data Hold from $\overline{WR}$ High	TDWD	1 TCP- $\Delta$	-	-	nS
$\overline{WR}$ Pulse Width	TDWR	6 TCP- $\Delta$	6 TCP	-	nS

Note: " $\Delta$ " (due to buffer driving delay and wire loading) is 20 nS.

## Port Access Cycle

PARAMETER	SYMBOL	MIN.	TYP.	MAX.	UNIT
Port Input Setup to ALE Low	TPDS	1 TCP	-	-	nS
Port Input Hold from ALE Low	TPDH	0	-	-	nS
Port Output to ALE	TPDA	1 TCP	-	-	nS

Note: Ports are read during S5P2, and output data becomes available at the end of S6P2. The timing data are referenced to ALE, since it provides a convenient reference.



## 8. TIMING WAVEFORMS

### 8.1 Program Fetch Cycle

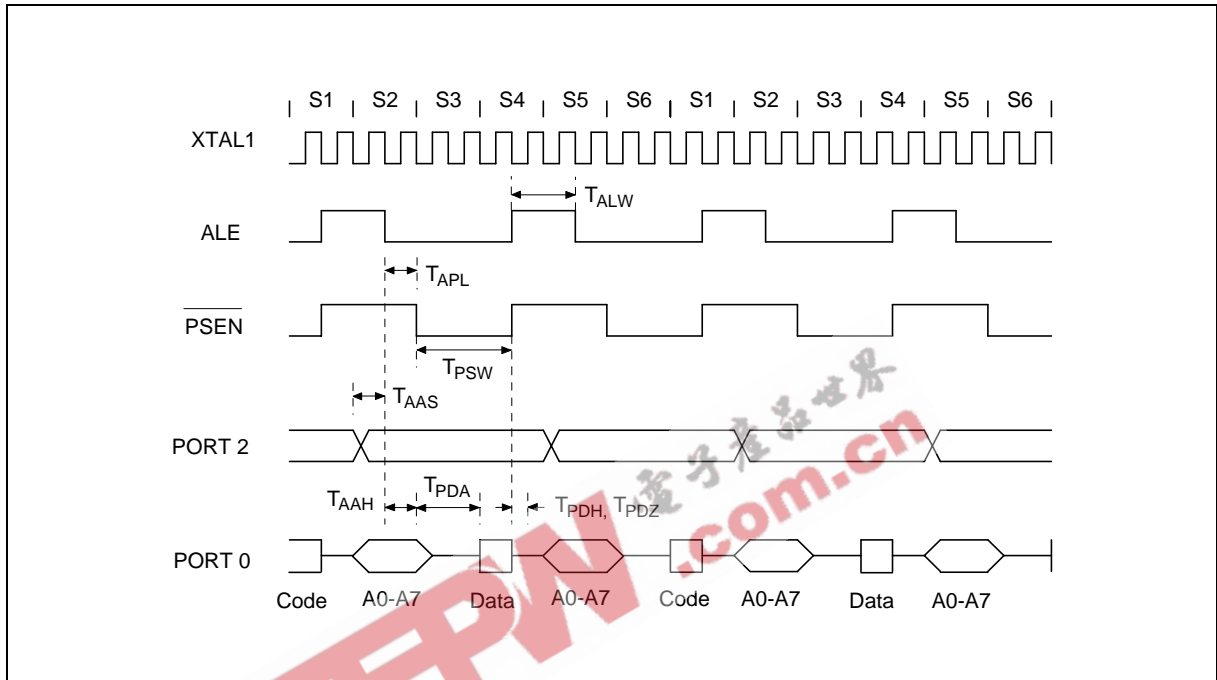

### 8.2 Data Read Cycle

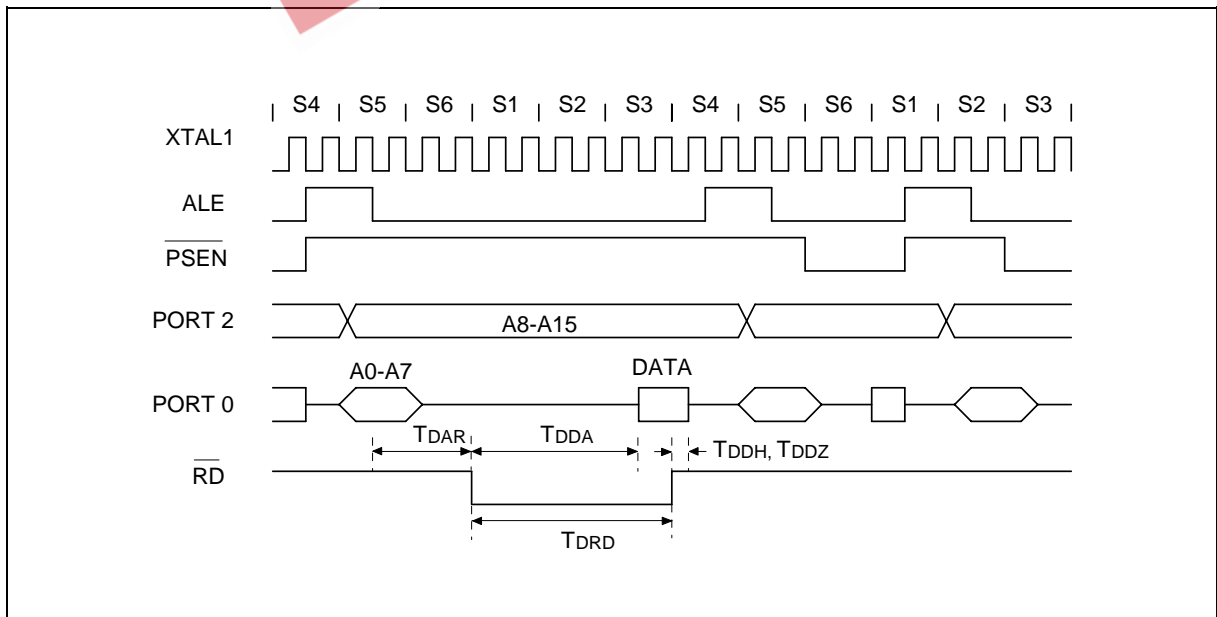

# W78LE516/W78L516A



Timing Waveforms, continued

## 8.3 Data Write Cycle

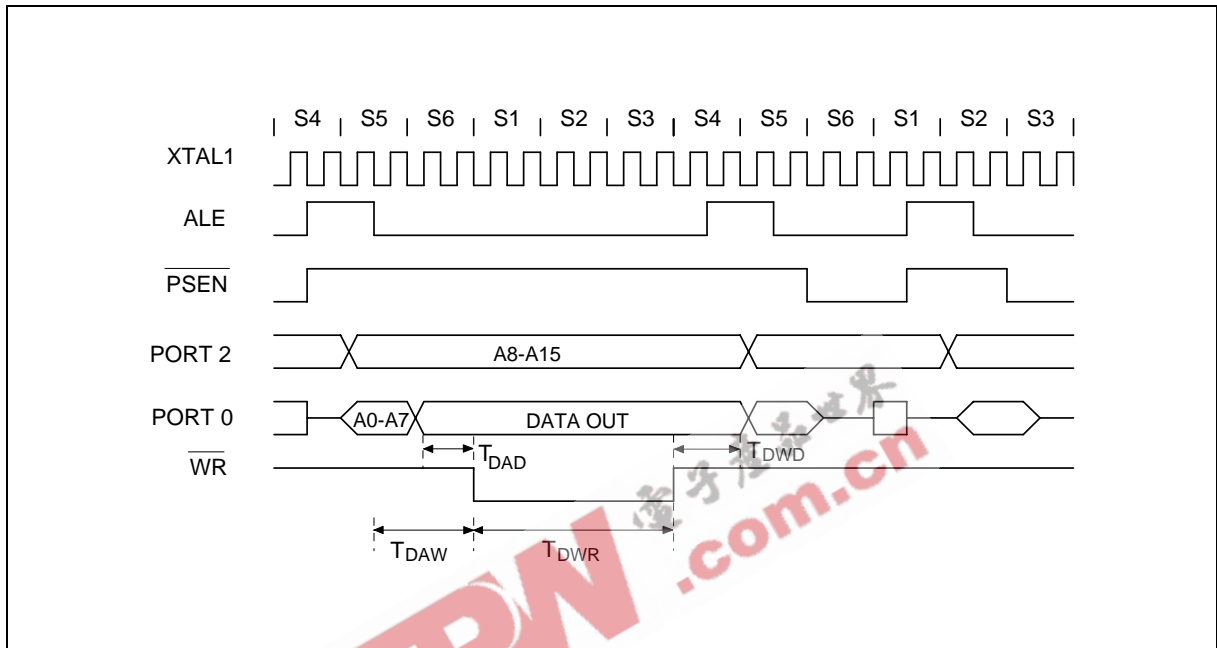

## 8.4 Port Access Cycle

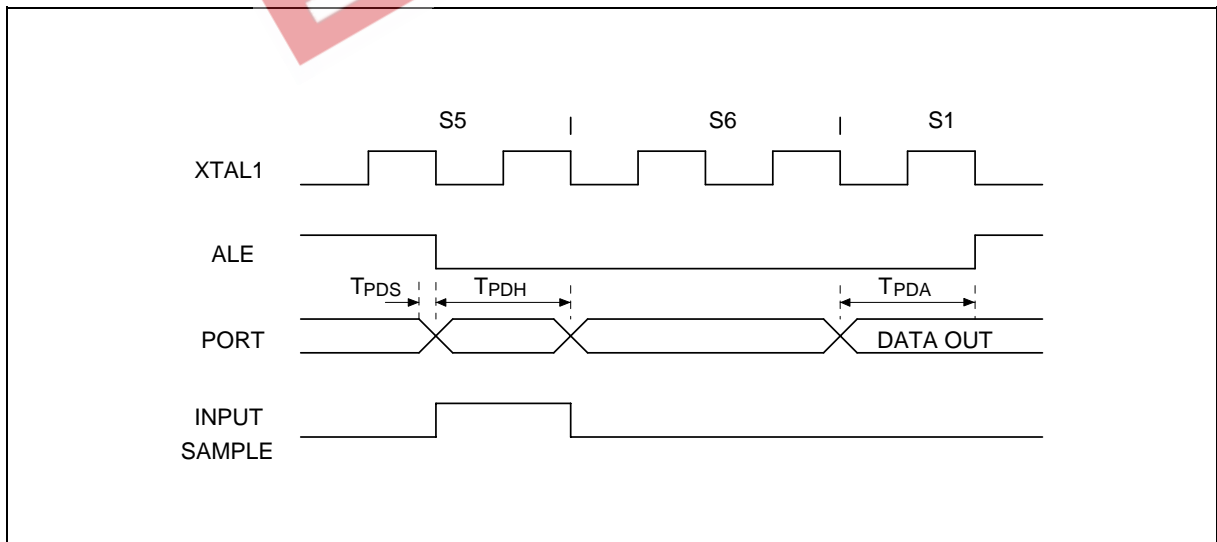

# W78LE516/W78L516A



## 9. TYPICAL APPLICATION CIRCUIT

### 9.1 External Program Memory and Crystal

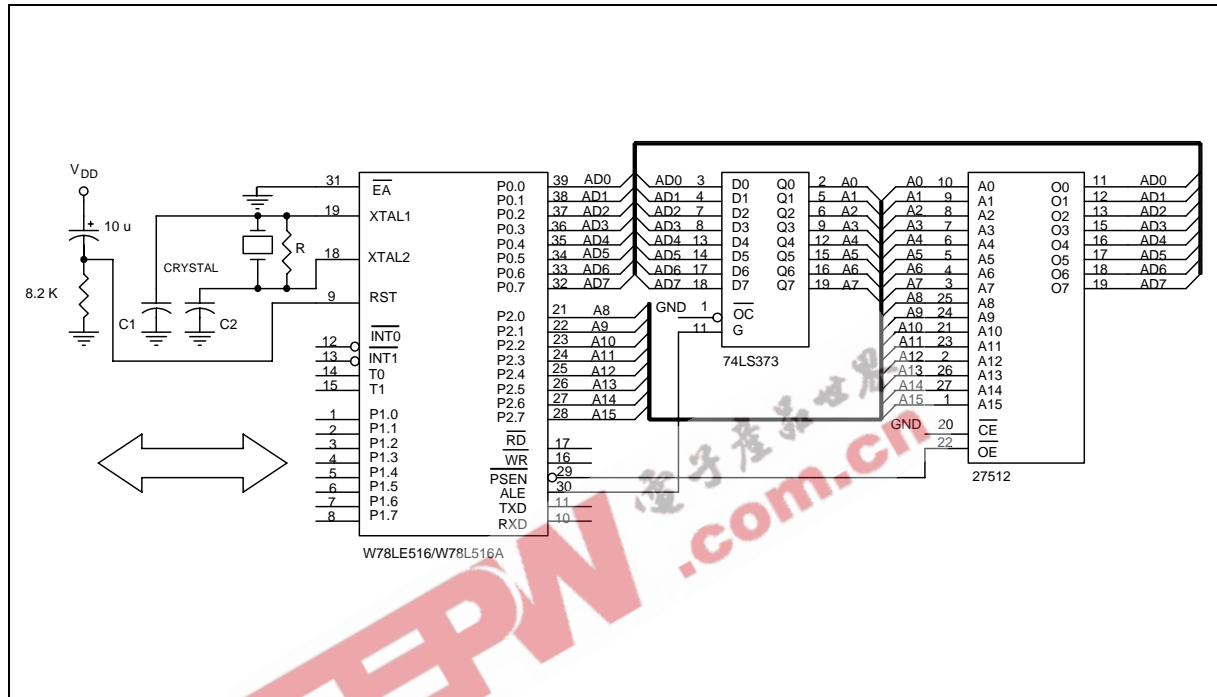

Figure A

CRYSTAL	C1	C2	R
6 MHz	47P	47P	-
16 MHz	30P	30P	-
20 MHz	15P	10P	-

Above table shows the reference values for crystal applications.

#### Notes:

1. C1, C2, R components refer to Figure A
2. Crystal layout must get close to XTAL1 and XTAL2 pins on user's application board.



# W78LE516/W78L516A



## 10. PACKAGE DIMENSIONS

### 10.1 40-pin DIP

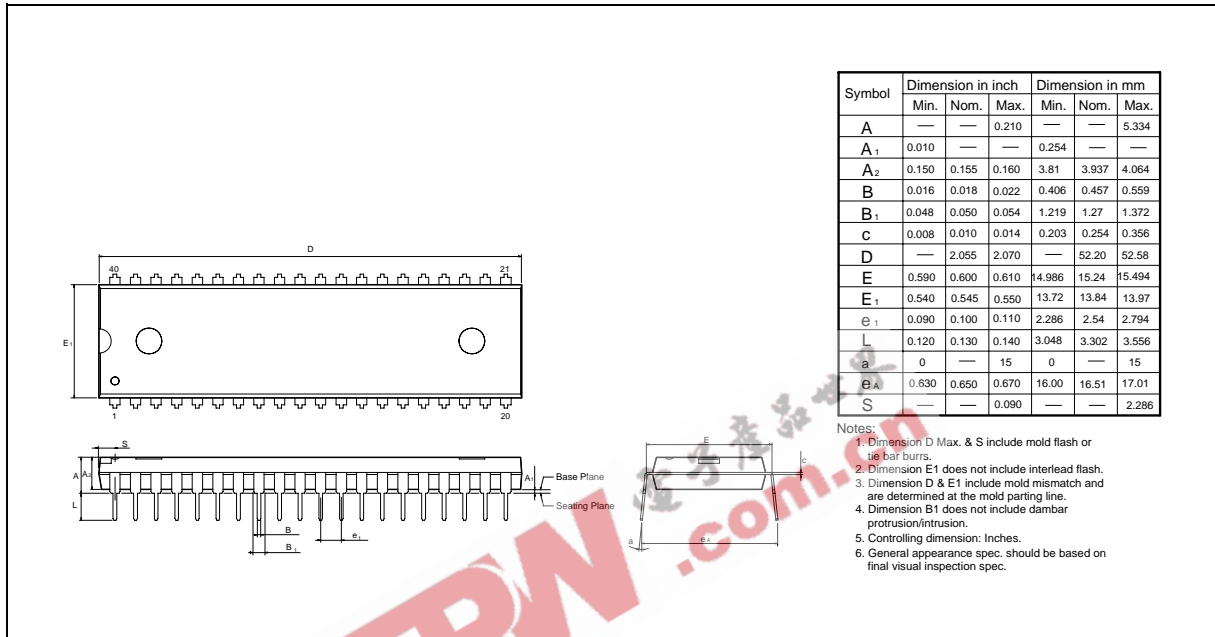

### 10.2 44-pin PLCC

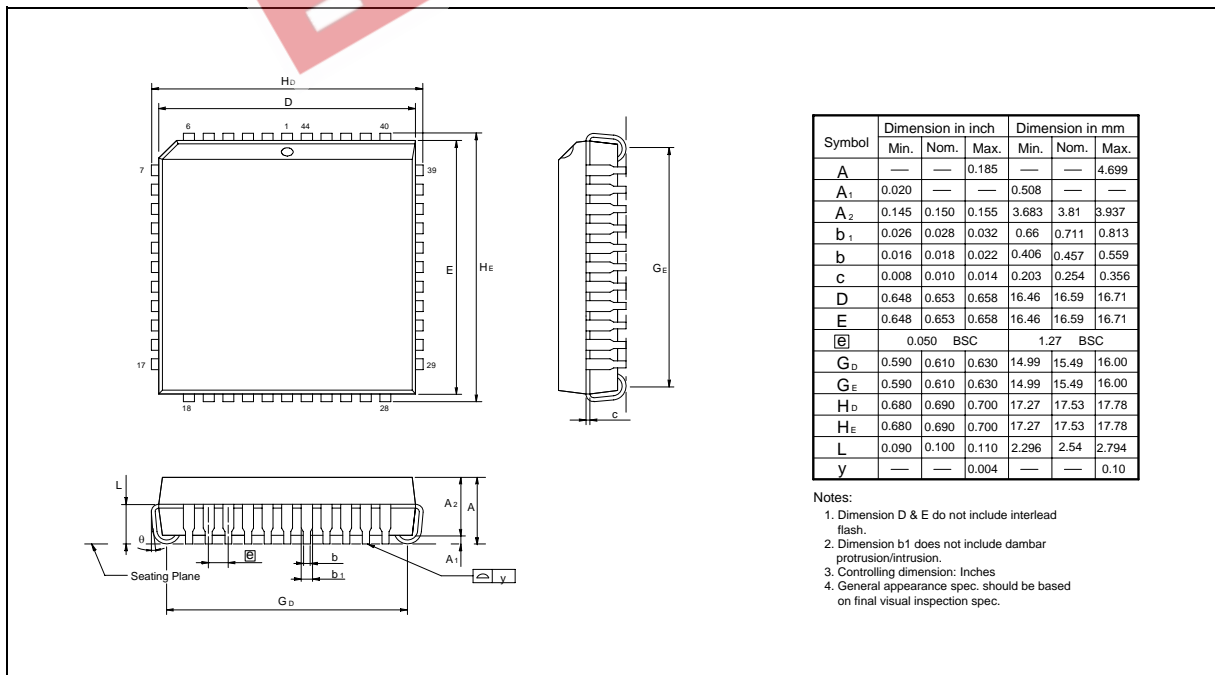

# W78LE516/W78L516A



Package Dimensions, continued

## 10.3 44-pin PQFP

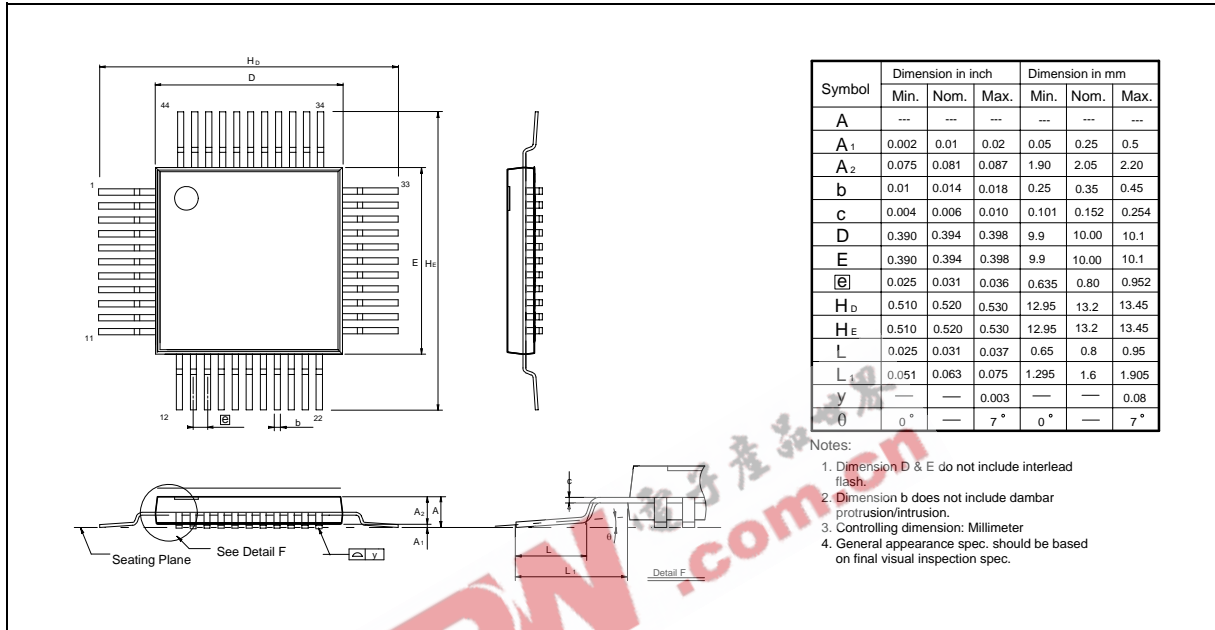

## 10.4 48-pin LQFP

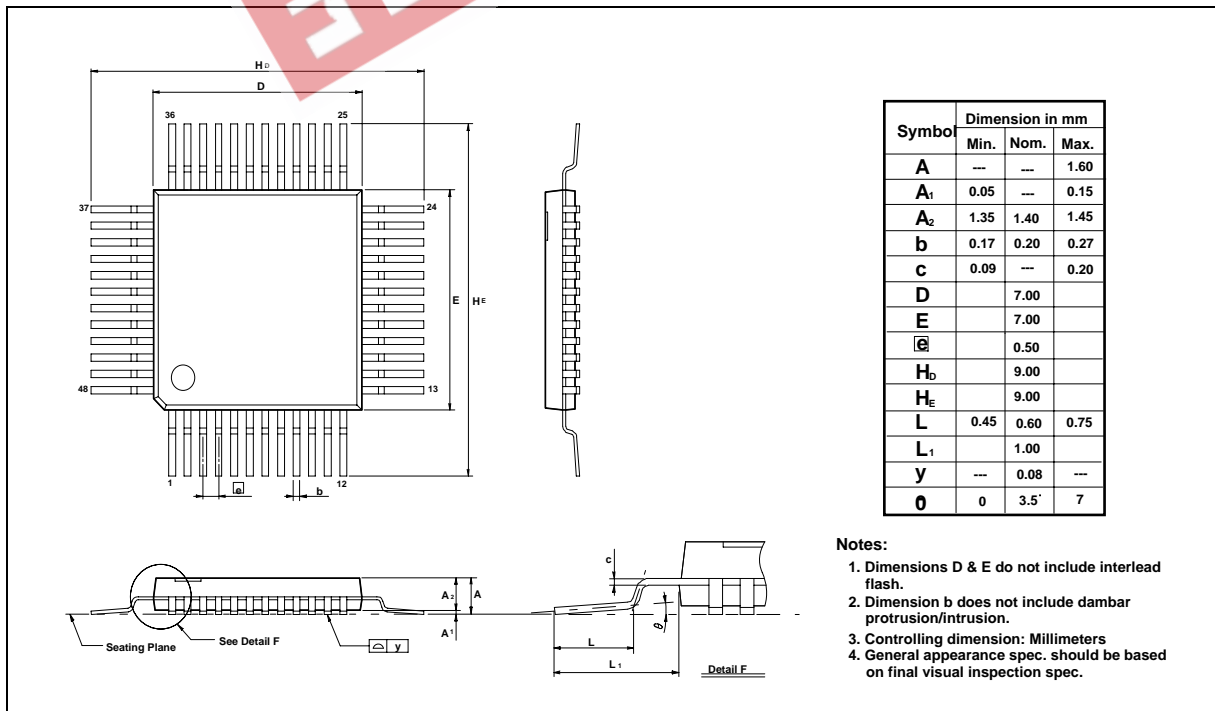

# W78LE516/W78L516A



## 11. APPLICATION NOTE: IN-SYSTEM PROGRAMMING SOFTWARE EXAMPLES

This application note illustrates the in-system programmability of the Winbond W78L516 Flash EPROM microcontroller. In this example, microcontroller will boot from 64 KB AP FLASH EPROM bank and waiting for a key to enter in-system programming mode for re-programming the contents of 64 KB AP FLASH EPROM. While entering in-system programming mode, microcontroller executes the loader program in 4KB LD FLASH EPROM bank. The loader program erases the 64 KB AP FLASH EPROM then reads the new code data from external SRAM buffer (or through other interfaces) to update the 64KB AP FLASH EPROM.

### EXAMPLE 1:

```
*****
;
;* Example of 64K AP FLASH EPROM program: Program will scan the P1.0. if P1.0 = 0, enters in-
system
;* programming mode for updating the content of AP FLASH EPROM code else executes the current
ROM code.
;* XTAL = 16 MHz
*****
;
    .chip 8052
    .RAMCHK OFF
    .symbols

    CHPCON EQU BFH
    CHPENR EQU F6H
    SFRAL EQU C4H
    SFRAH EQU C5H
    SFRFD EQU C6H
    SFRCN EQU C7H

    ORG 0H
    LJMP 100H ; JUMP TO MAIN PROGRAM

*****
;
;* TIMER0 SERVICE VECTOR ORG = 000BH
*****
;
    ORG 00BH
    CLR TR0 ; TR0 = 0, STOP TIMER0
    MOV TL0, R6
    MOV TH0, R7
    RETI

*****
;
;* 64K AP FLASH EPROM MAIN PROGRAM
*****
;
    ORG 100H

MAIN_64K:
    MOV A, P1 ; SCAN P1.0
    ANL A, #01H
    CJNE A, #01H, PROGRAM_64K ; IF P1.0 = 0, ENTER IN-SYSTEM PROGRAMMING MODE
    JMP NORMAL_MODE

PROGRAM_64K:
    MOV CHPENR, #87H ; CHPENR = 87H, CHPCON REGISTER WRTE ENABLE
    MOV CHPENR, #59H ; CHPENR = 59H, CHPCON REGISTER WRITE ENABLE
    MOV CHPCON, #03H ; CHPCON = 03H, ENTER IN-SYSTEM PROGRAMMING MODE
```



# W78LE516/W78L516A



```
MOV TCON, #00H      ; TR = 0 TIMER0 STOP
MOV IP, #00H        ; IP = 00H
MOV IE, #82H        ; TIMER0 INTERRUPT ENABLE FOR WAKE-UP FROM IDLE MODE
MOV R6, #F0H        ; TL0 = F0H
MOV R7, #FFH        ; TH0 = FFH
MOV TL0, R6
MOV TH0, R7
MOV TMOD, #01H      ; TMOD = 01H, SET TIMER0 A 16-BIT TIMER
MOV TCON, #10H      ; TCON = 10H, TR0 = 1, GO
MOV PCON, #01H      ; ENTER IDLE MODE FOR LAUNCHING THE IN-SYSTEM
                    ; PROGRAMMING
```

\*\*\*\*\*

;\* Normal mode 64KB AP FLASH EPROM program: depending user's application

\*\*\*\*\*

NORMAL\_MODE:

. ; User's application program

.  
.  
.  
.

## EXAMPLE 2:

\*\*\*\*\* ;\*  
Example of 4 KB LD FLASH EPROM program: This loader program will erase the 64KB AP FLASH EPROM first, then reads the new ;\* code from external SRAM and program them into 64 KB AP FLASH EPROM bank. XTAL = 16 MHz

\*\*\*\*\*

```
.chip 8052
.RAMCHK OFF
.symbols
```

```
CHPCON EQU BFH
CHPENR EQU F6H
SFRAL EQU C4H
SFRAH EQU C5H
SFRFD EQU C6H
SFRCN EQU C7H
```

```
ORG 000H
LJMP 100H ; JUMP TO MAIN PROGRAM
```

\*\*\*\*\*

;\* 1. TIMER0 SERVICE VECTOR ORG = 0BH

\*\*\*\*\*

```
ORG 000BH
CLR TR0 ; TR0 = 0, STOP TIMER0
MOV TL0, R6
MOV TH0, R7
RETI
```

\*\*\*\*\*

;\* 4KB LD FLASH EPROM MAIN PROGRAM

\*\*\*\*\*

# W78LE516/W78L516A



```
ORG 100H
MAIN_4K:
    MOV SP, #C0H      ; BE INITIAL SP REGISTER
    MOV CHPENR, #87H ; CHPENR = 87H, CHPCON WRITE ENABLE.
    MOV CHPENR, #59H ; CHPENR = 59H, CHPCON WRITE ENABLE.
    MOV A, CHPCON
    ANL A, #80H
    CJNE A, #80H, UPDATE_64K ; CHECK H/W REBOOT MODE ?

    MOV CHPCON, #03H ; CHPCON = 03H, ENABLE IN-SYSTEM PROGRAMMING.
    MOV CHPENR, #00H ; DISABLE CHPCON WRITE ATTRIBUTE

    MOV TCON, #00H ; TCON = 00H, TR = 0 TIMER0 STOP
    MOV TMOD, #01H ; TMOD = 01H, SET TIMER0 A 16BIT TIMER
    MOV IP, #00H ; IP = 00H
    MOV IE, #82H ; IE = 82H, TIMER0 INTERRUPT ENABLED
    MOV R6, #F0H
    MOV R7, #FFH
    MOV TL0, R6
    MOV TH0, R7
    MOV TCON, #10H ; TCON = 10H, TR0 = 1, GO
    MOV PCON, #01H ; ENTER IDLE MODE

UPDATE_64K:
    MOV CHPENR, #00H ; DISABLE CHPCON WRITE-ATTRIBUTE
    MOV TCON, #00H ; TCON = 00H, TR = 0 TIM0 STOP
    MOV IP, #00H ; IP = 00H
    MOV IE, #82H ; IE = 82H, TIMER0 INTERRUPT ENABLED
    MOV TMOD, #01H ; TMOD = 01H, MODE1
    MOV R6, #E0H ; SET WAKE-UP TIME FOR ERASE OPERATION, ABOUT 15 mS. DEPENDING
    ; ON USER'S SYSTEM CLOCK RATE.

    MOV R7, #B1H
    MOV TL0, R6
    MOV TH0, R7

ERASE_P_4K:
    MOV SFRCN, #22H ; SFRCN (C7H) = 22H ERASE 64K
    MOV TCON, #10H ; TCON = 10H, TR0 = 1, GO
    MOV PCON, #01H ; ENTER IDLE MODE (FOR ERASE OPERATION)

;*****
; * BLANK CHECK
;*****
    MOV SFRCN, #0H ; READ 64KB AP FLASH EPROM MODE
    MOV SFRAH, #0H ; START ADDRESS = 0H
    MOV SFRAL, #0H
    MOV R6, #FEH ; SET TIMER FOR READ OPERATION, ABOUT 1.5 μS.
    MOV R7, #FFH
    MOV TL0, R6
    MOV TH0, R7

BLANK_CHECK_LOOP:
    SETB TR0 ; ENABLE TIMER 0
    MOV PCON, #01H ; ENTER IDLE MODE
    MOV A, SFRFD ; READ ONE BYTE
    CJNE A, #FFH, BLANK_CHECK_ERROR
```

# W78LE516/W78L516A



```
INC SFRAL          ; NEXT ADDRESS
MOV A, SFRAL
JNZ BLANK_CHECK_LOOP
INC SFRAH
MOV A, SFRAH
CJNE A, #0H, BLANK_CHECK_LOOP ; END ADDRESS = FFFFH
JMP PROGRAM_64KROM
```

BLANK\_CHECK\_ERROR:

```
MOV P1, #F0H
MOV P3, #F0H
JMP $
```

```
.*****
;
;* RE-PROGRAMMING 64KB AP FLASH EPROM BANK
;*****
```

PROGRAM\_64KROM:

```
MOV DPTR, #0H          ; THE ADDRESS OF NEW ROM CODE
MOV R2, #00H           ; TARGET LOW BYTE ADDRESS
MOV R1, #00H           ; TARGET HIGH BYTE ADDRESS
MOV DPTR, #0H         ; EXTERNAL SRAM BUFFER ADDRESS
MOV SFRAH, R1          ; SFRAH, TARGET HIGH ADDRESS
MOV SFRCN, #21H        ; SFRCN (C7H) = 21 (PROGRAM 64K)
MOV R6, #BEH           ; SET TIMER FOR PROGRAMMING, ABOUT 50 μS.
MOV R7, #FFH
MOV TL0, R6
MOV TH0, R7
```

PROG\_D\_64K:

```
MOV SFRAL, R2          ; SFRAL (C4H) = LOW BYTE ADDRESS
MOVX A, @DPTR          ; READ DATA FROM EXTERNAL SRAM BUFFER. BY ACCORDING USER?
;                      ; CIRCUIT, USER MUST MODIFY THIS INSTRUCTION TO FETCH CODE.
MOV SFRFD, A           ; SFRFD (C6H) = DATA IN
MOV TCON, #10H         ; TCON = 10H, TR0 = 1, GO
MOV PCON, #01H        ; ENTER IDLE MODE (PROGAMMING)
INC DPTR
INC R2
CJNE R2, #0H, PROG_D_64K
INC R1
MOV SFRAH, R1
CJNE R1, #0H, PROG_D_64K
```

```
.*****
;
; * VERIFY 64KB AP FLASH EPROM BANK
;*****
```

```
MOV R4, #03H          ; ERROR COUNTER
MOV R6, #FEH          ; SET TIMER FOR READ VERIFY, ABOUT 1.5 μS.
MOV R7, #FFH
MOV TL0, R6
MOV TH0, R7
MOV DPTR, #0H         ; The start address of sample code
MOV R2, #0H           ; Target low byte address
MOV R1, #0H           ; Target high byte address
MOV SFRAH, R1         ; SFRAH, Target high address
MOV SFRCN, #00H       ; SFRCN = 00 (Read Flash code)
```

## W78LE516/W78L516A



READ\_VERIFY\_64K:

```
MOV SFRAL, R2      ; SFRAL (C4H) = LOW ADDRESS
MOV TCON, #10H    ; TCON = 10H, TR0 = 1, GO
MOV PCON, #01H
INC R2
MOVX A, @DPTR
INC DPTR
CJNE A, SFRFD, ERROR_64K
CJNE R2, #0H, READ_VERIFY_64K
INC R1
MOV SFRAH, R1
CJNE R1, #0H, READ_VERIFY_64K
```

```
.*****
;
;* PROGRAMMING COMPLETELY, SOFTWARE RESET CPU
;*****
```

```
MOV CHPENR, #87H   ; CHPENR = 87H
MOV CHPENR, #59H   ; CHPENR = 59H
MOV CHPCON, #83H   ; CHPCON = 83H, SOFTWARE RESET.
```

ERROR\_64K:

```
DJNZ R4, UPDATE_64K ; IF ERROR OCCURS, REPEAT 3 TIMES.
.                   ; IN-SYSTEM PROGRAMMING FAIL, USER'S PROCESS TO DEAL WITH IT.
.
.
.
```

# W78LE516/W78L516A



## 12. REVISION HISTORY

VERSION	DATE	PAGE	DESCRIPTION
A3	March, 2001	-	Initial Issued
A4	August, 2004	1	Insert table
		30	Revise the sub-title of chapter 10.
A5	Feb. 15, 2005	3	Add Lead Free package
A6	April 19, 2005	37	Add Important Notice
A7	November 6, 2006		Remove block diagram
		3	Remove all Leaded parts

### Important Notice

Winbond products are not designed, intended, authorized or warranted for use as components in systems or equipment intended for surgical implantation, atomic energy control instruments, airplane or spaceship instruments, transportation instruments, traffic signal instruments, combustion control instruments, or for other applications intended to support or sustain life. Further more, Winbond products are not intended for applications wherein failure of Winbond products could result or lead to a situation wherein personal injury, death or severe property or environmental damage could occur.

Winbond customers using or selling these products for use in such applications do so at their own risk and agree to fully indemnify Winbond for any damages resulting from such improper use or sales.

Please note that all data and specifications are subject to change without notice.  
All the trademarks of products and companies mentioned in this datasheet belong to their respective owners.

*Publication Release Date: November 6, 2006*

*Revision A7*