

isc Silicon NPN Darlington Power Transistor

BDW23/A/B/C

DESCRIPTION

- Collector Current - $I_C= 6A$
- High DC Current Gain- $h_{FE}= 750(\text{Min}) @ I_C= 2A$
- Complement to Type BDW24/A/B/C

APPLICATIONS

- Designed for hammer drivers, audio amplifiers applications

ABSOLUTE MAXIMUM RATINGS($T_a=25^\circ\text{C}$)

SYMBOL	PARAMETER	VALUE	UNIT	
V_{CER}	Collector-Emitter Voltage	BDW23	45	V
		BDW23A	60	
		BDW23B	80	
		BDW23C	100	
V_{CEO}	Collector-Emitter Voltage	BDW23	45	V
		BDW23A	60	
		BDW23B	80	
		BDW23C	100	
V_{EBO}	Emitter-Base Voltage	5	V	
I_C	Collector Current-Continuous	6	A	
I_{CM}	Collector Current-Peak	8	A	
I_B	Base Current-Continuous	0.2	A	
P_C	Collector Power Dissipation @ $T_C=25^\circ\text{C}$	50	W	
T_J	Junction Temperature	150	$^\circ\text{C}$	
T_{stg}	Storage Temperature Range	-65~150	$^\circ\text{C}$	

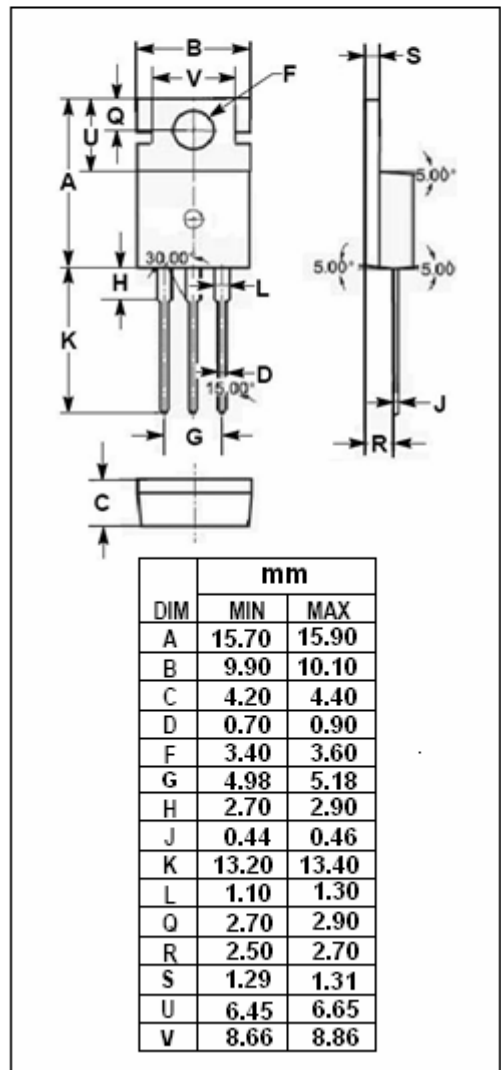
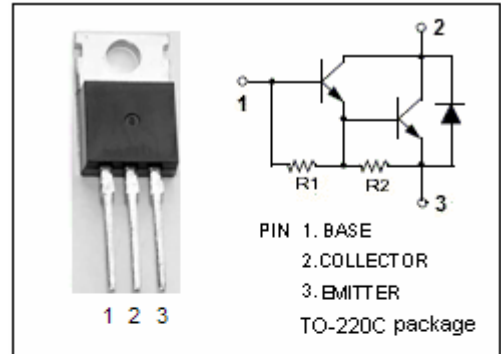

isc Silicon NPN Darlington Power Transistor

BDW23/A/B/C

ELECTRICAL CHARACTERISTICS

 $T_C=25^\circ\text{C}$ unless otherwise specified

SYMBOL	PARAMETER	CONDITIONS	MIN	TYP.	MAX	UNIT
$V_{(BR)CEO}$	Collector-Emitter Breakdown Voltage	BDW23	$I_C=100\text{mA}; I_B=0$			V
		BDW23A				
		BDW23B				
		BDW23C				
$V_{CE(sat)-1}$	Collector-Emitter Saturation Voltage	$I_C=2\text{A}; I_B=8\text{mA}$			2	V
$V_{CE(sat)-2}$	Collector-Emitter Saturation Voltage	$I_C=6\text{A}; I_B=60\text{mA}$			3	V
$V_{BE(sat)}$	Base-Emitter Saturation Voltage	$I_C=2\text{A}; I_B=8\text{mA}$			2.5	V
$V_{BE(on)-1}$	Base-Emitter On Voltage	$I_C=1\text{A}; V_{CE}=3\text{V}$			2.5	V
$V_{BE(on)-2}$	Base-Emitter On Voltage	$I_C=6\text{A}; V_{CE}=3\text{V}$			3	V
V_{ECF}	C-E Diode Forward Voltage	$I_F=2\text{A}$			1.8	V
I_{CEO}	Collector Cutoff Current	BDW23			0.5	mA
		BDW23A				
		BDW23B				
		BDW23C				
I_{CBO}	Collector Cutoff Current	BDW23			0.2	mA
		BDW23A				
		BDW23B				
		BDW23C				
I_{EBO}	Emitter Cutoff Current	$V_{EB}=5\text{V}; I_C=0$			2	mA
h_{FE-1}	DC Current Gain	$I_C=1\text{A}; V_{CE}=3\text{V}$	1000			
h_{FE-2}	DC Current Gain	$I_C=2\text{A}; V_{CE}=3\text{V}$	750		20000	
h_{FE-3}	DC Current Gain	$I_C=6\text{A}; V_{CE}=3\text{V}$	100			