

IVRVGC0118

Page 1 of 2

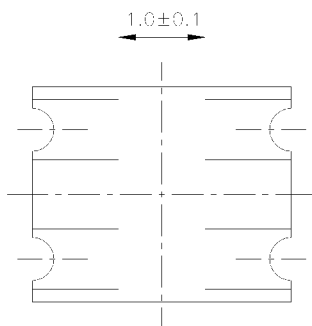

These lamps are miniature chip type designed for surface mounting and measure approximately 2.5 x 3 mm.

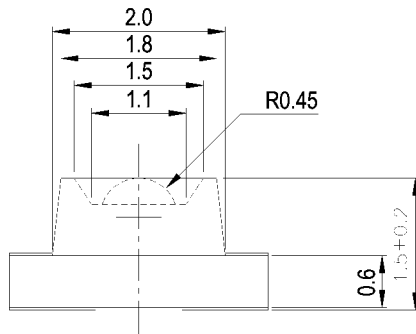
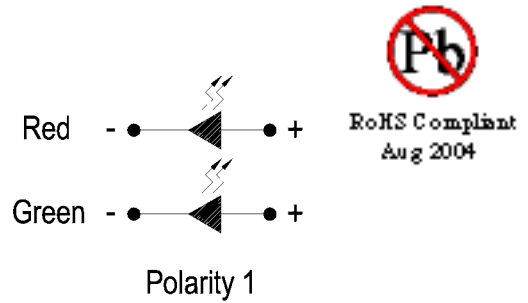
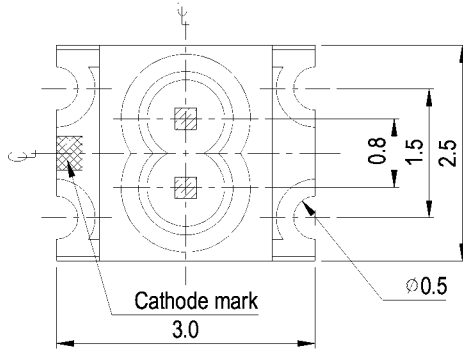

For reflow soldering (propose)

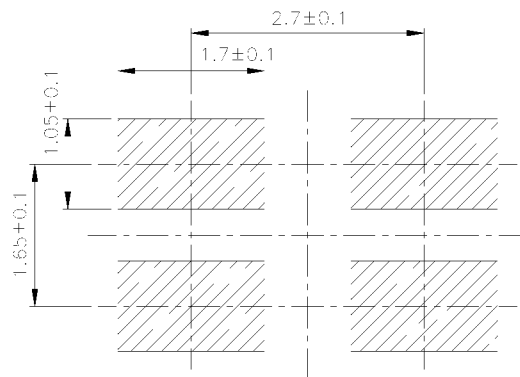

PART NO.	Chip		Lens Color
	Material	Emitted Color	
IVRVGC0118	GaAsP/GaP	Red	Water Clear
	GaP	Green	

* Specifications subject to change without notice. Dimensions are in mm±0.1 unless stated otherwise.

IDEA, Inc., 1351 Titan Way, Brea, CA 92821 Ph:714-525-3302, 800-LED-IDEA; Fax: 714-525-3304 0507

Absolute Maximum Ratings at $T_a = 25\text{ }^\circ\text{C}$

Parameter	Symbol	Rating	Units
Forward Current	I_F	VR 30	mA
		VG 30	
Operating Temperature	T_{opr}	-40 to +85	$^\circ\text{C}$
Storage Temperature	T_{stg}	-40 to +90	$^\circ\text{C}$
Soldering Temperature	T_{sol}	260 (for 5 seconds)	$^\circ\text{C}$
Electrostatic Discharge	ESD	2000	V
Power Dissipation	P_d	VR 100	mW
		VG 100	
Peak Forward Current (Duty 1/10 @ 1KHz)	I_F (Peak)	VR 60	mA
		VG 60	
Reverse Voltage	V_R	5	V

Electronic Optical Characteristics

Parameter	Symbol	Min.	Typ.	Max.	Units	Condition
Luminous Intensity	I_V	VR 7	10.5	—	mcd	$I_F = 20\text{ mA}$
		VG 14	21	—		
Viewing Angle	$2\theta_{1/2}$	—	60	—	deg	$I_F = 20\text{ mA}$
Peak Wavelength	λ_p	VR —	640	—	nm	$I_F = 20\text{ mA}$
		VG —	570	—		
Dominant Wavelength	λ_d	VR —	625	—	nm	$I_F = 20\text{ mA}$
		VG —	571	—		
Spectrum Radiation Bandwidth	$\Delta\lambda$	VR —	45	—	nm	$I_F = 20\text{ mA}$
		VG —	30	—		
Forward Voltage	V_F	VR 1.7	2.0	2.4	V	$I_F = 20\text{ mA}$
		VG 1.7	2.1	2.4		
Reverse Current	I_R	—	—	10	μA	$V_R = 5\text{ V}$

* Specifications subject to change without notice. Dimensions are in mm±0.1 unless stated otherwise.