

# KH220

## Fast Settling Wideband Op Amp

### Features

- -3dB bandwidth of 190MHz
- 0.1% settling in 8ns
- 7000V/μs slew rate
- 1.9ns rise and fall times
- Low distortion, linear phase
- Direct replacement for CLC220

### Applications

- Very high-speed A to D, D to A conversion
- High-speed fiber optic systems
- Baseband and video communications
- Radar and IF processors
- Very fast risetime pulse amplifiers

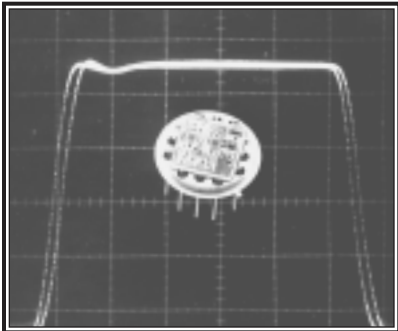

**Bottom View**

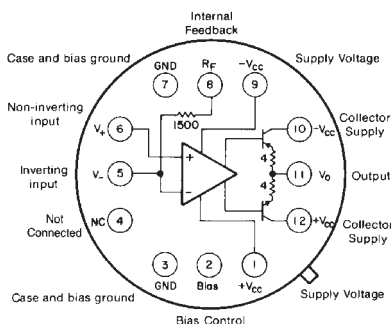

Pin 8 provides access to a 1500 ohm feedback resistor. Pin 2 allows the user to reduce the amplifier supply current or to turn the amplifier off completely.

### Typical Performance

parameter	gain setting						units
	+4	+20	+50	-4	-20	-50	
-3dB bandwidth	250	190	120	200	190	150	MHz
rise time (2V)	1.6	1.9	2.3	1.6	1.9	2.3	ns
slew rate	7	7	7	7	7	7	V/ns
settling time (0.1%)	10	8	10	8	8	10	ns

### General Description

The KH220 is a wide bandwidth DC-coupled operational amplifier that defines the state-of-the-art in high speed op amps. A -3dB bandwidth of DC to 190MHz is achieved using a current feedback architecture design. Ultra-fast settling time (8nsec to 0.1%) and slew rate (7000V/μsec) make the KH220 a superior amplifier for pulsed and digital applications.

Since thermal tail has been eliminated, the KH220 settles fast and remains solidly at the desired level. Flat gain and linear phase (1.2° deviation from linear) from DC to beyond 100MHz help the KH220 to achieve distortion levels uncommonly low relative to conventional op amps.

Using the KH220 is as easy as adding power supplies and a gain-setting resistor. The result is reliable, consistent performance because such characteristics as bandwidth and settling time are virtually independent of gain setting. Unlike conventional op amp designs where the optimum gain-bandwidth product occurs at a high gain, minimum settling time at a gain of -1, maximum slew rate at a gain of +1, et cetera, the KH220 offers predictable response at gain settings from ±1 to ±50. This, coupled with consistent performance from unit to unit with no external compensation, makes the KH220 a real time and cost-saver in design and production situations alike.

This combination of features makes the KH220 appropriate for a broad range of applications. The wide bandwidth, DC coupling, and fast settling lend themselves well to high speed D to A and "flash" A to D applications. Both receivers and transmitters in optical fiber systems have similar requirements. High gain and phase linearity and corresponding low distortion make the KH220 ideal for many digital communication system applications, such as in the demodulator, where the need for both DC coupling and high frequency amplification creates requirements that are difficult to meet.

The KH220 is constructed using thin film resistor/bipolar transistor technology, and available in these versions:

KH220AI	-25°C to +85°C	12-pin TO-8 can
KH220AK	-55°C to +125°C	12-pin TO-8 can, features burn-in & hermetic testing
KH220AM	-55°C to +125°C	12-pin TO-8 can, environmentally screened and electrically tested to MIL-STD-883
KH220HXC	-55°C to +125°C	SMD#: 5962-8991101HXC
KH220HXA	-55°C to +125°C	SMD#: 5962-8991101HXA

### KH220 Electrical Characteristics ( $V_A = +20V, V_{CC} = \pm 15V, R_L = 200\Omega, R_f = 1500\Omega$ ; unless specified)

PARAMETERS	CONDITIONS	TYP	MAX & MIN RATINGS <sup>1</sup>				UNITS	SYMBOL
			+25°C	-25°C	+25°C	+85°C		
Ambient Temperature	KH220AI	+25°C	-25°C	+25°C	+85°C			
Ambient Temperature	KH220AK/AM/HXC/HXA	+25°C	-55°C	+25°C	+125°C			
<b>FREQUENCY DOMAIN RESPONSE</b>								
† -3dB bandwidth	$V_{out} < 2V_{pp}$	190	>160	>170	>150	MHz	SSBW	
gain flatness at	$V_{out} < 2V_{pp}$							
† peaking	0.1 to 50MHz	0	<0.5	<0.3	<0.4	dB	GFPL	
† peaking	>50MHz	0	<1.5	<0.6	<1.0	dB	GFPH	
† rolloff	at 100MHz	0	<0.4	<0.6	<0.9	dB	GFR	
group delay	to 100MHz	3.0±0.3	—	—	—	ns	GD	
linear phase deviation	to 100MHz	1.2	<2	<2	<2	°	LPD	
reverse isolation	to 100MHz							
non-inverting		60	>50	>50	>50	dB	RINI	
inverting		45	>35	>35	>35	dB	RIIN	
<b>TIME DOMAIN RESPONSE</b>								
rise and fall time	2V step	1.9	<2.2	<2.1	<2.2	ns	TRS	
	5V step	2	<2.6	<2.5	<2.6	ns	TRL	
settling time to .02%	5V step <sup>4</sup>	15	—	—	—	ns	TSP	
to .1%	5V step <sup>4</sup>	8	<15	<12	<15	ns	TS	
overshoot	5V step	7	<15	<12	<12	%	OS	
slew rate (overdriven input)		7	>6	>6	>6	V/ns	SR	
overload recovery								
<50ns pulse, 200% overdrive		25	—	—	—	ns	OR	
<b>DISTORTION AND NOISE RESPONSE</b>								
† 2nd harmonic distortion	2V <sub>pp</sub> , 20MHz	-58	<-50	<-50	<-50	dBc	HD2	
† 3rd harmonic distortion	2V <sub>pp</sub> , 20MHz	-62	<-50	<-50	<-50	dBc	HD3	
equivalent noise input								
noise floor	>100kHz	-156	<-150	<-150	<-150	dBm(1Hz)	SNF	
integrated noise	1kHz to 200MHz	50	<100	<100	<100	μV	INV	
noise floor	>5MHz	-156	<-150	<-150	<-150	dBm(1Hz)	SNF	
integrated noise	5MHz to 200MHz	50	<100	<100	<100	μV	INV	
<b>STATIC DC PERFORMANCE</b>								
*input offset voltage		10	<25	<25	<25	mV	VIO	
average temperature coefficient		35	<120	<120	<120	μV/°C	DVIO	
*input bias current	non-inverting	10	<40	<30	<40	μA	IBN	
average temperature coefficient		20	<125	<125	<125	nA/°C	DIBN	
*input bias current	inverting	20	<70	<50	<70	μA	IBI	
average temperature coefficient		70	<250	<250	<250	nA/°C	DIBI	
*power supply rejection ratio		55	>45	>45	>45	dB	PSRR	
common mode rejection ratio		46	>40	>40	>40	dB	CMRR	
*supply current	no load	30	<36	<34	<36	mA	ICC	
<b>MISCELLANEOUS PERFORMANCE</b>								
non-inverting input	resistance	250	>100	>100	>100	kΩ	RIN	
	capacitance	2.4	<3	<3	<3	pF	CIN	
output impedance	at DC	—	<0.1	<0.1	<0.1	Ω	RO	
	at 100MHz	1, 35	—	—	—	Ω, nH	ZO	
output voltage range	no load	—	>±10	>±10	>±10	V	VO	
internal feedback resistor	absolute tolerance	<0.4	—	—	—	%	RFA	

Min/max ratings are based on product characterization and simulation. Individual parameters are tested as noted. Outgoing quality levels are determined from tested parameters.

### Absolute Maximum Ratings

Common Mode and Output Voltage Limits

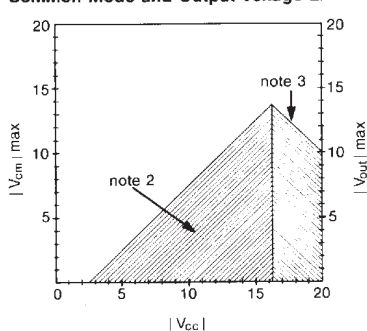

- supply voltage ( $V_{CC}$ ) ±20V
- output current ±50mA
- thermal resistance ( $\theta_{ca}$ ) see thermal model
- junction temperature +175°C
- operating temperature AI: -25°C to +85°C
- AK/AM/HXC/HXA: -55°C to +125°C
- storage temperature -65°C to +150°C
- lead temperature (soldering 10s) +300°C

- note 1:** \* AI/AK/AM/HXC/HXA 100% tested at 25°C.  
† AK/AM/HXC/HXA 100% tested at +25°C & sample tested at -55°C & +125°C.  
‡ AI sample tested at +25°C.
- note 2:** This rating protects against damage to the input stage caused by saturation of either the input or output stages. Under transient conditions not exceeding 1μs (duty cycle not exceeding 10%), maximum input voltage may be as large as twice the maximum.  $V_{cm}$  should never exceed  $V_{CC}$  ( $V_{cm}$  is the voltage at the non-inverting input, pin 6).
- note 3:** This rating protects against exceeding transistor collector-emitter breakdown ratings. Recommended  $V_{CC}$  is ±15V.
- note 4:** Settling time specification requires the use of an external feedback resistor (1500Ω).

# KH220 Typical Performance Characteristics ( $T_A = +25^\circ$ , $A_v = +20$ , $V_{CC} = \pm 15V$ , $R_L = 200\Omega$ ; unless specified)

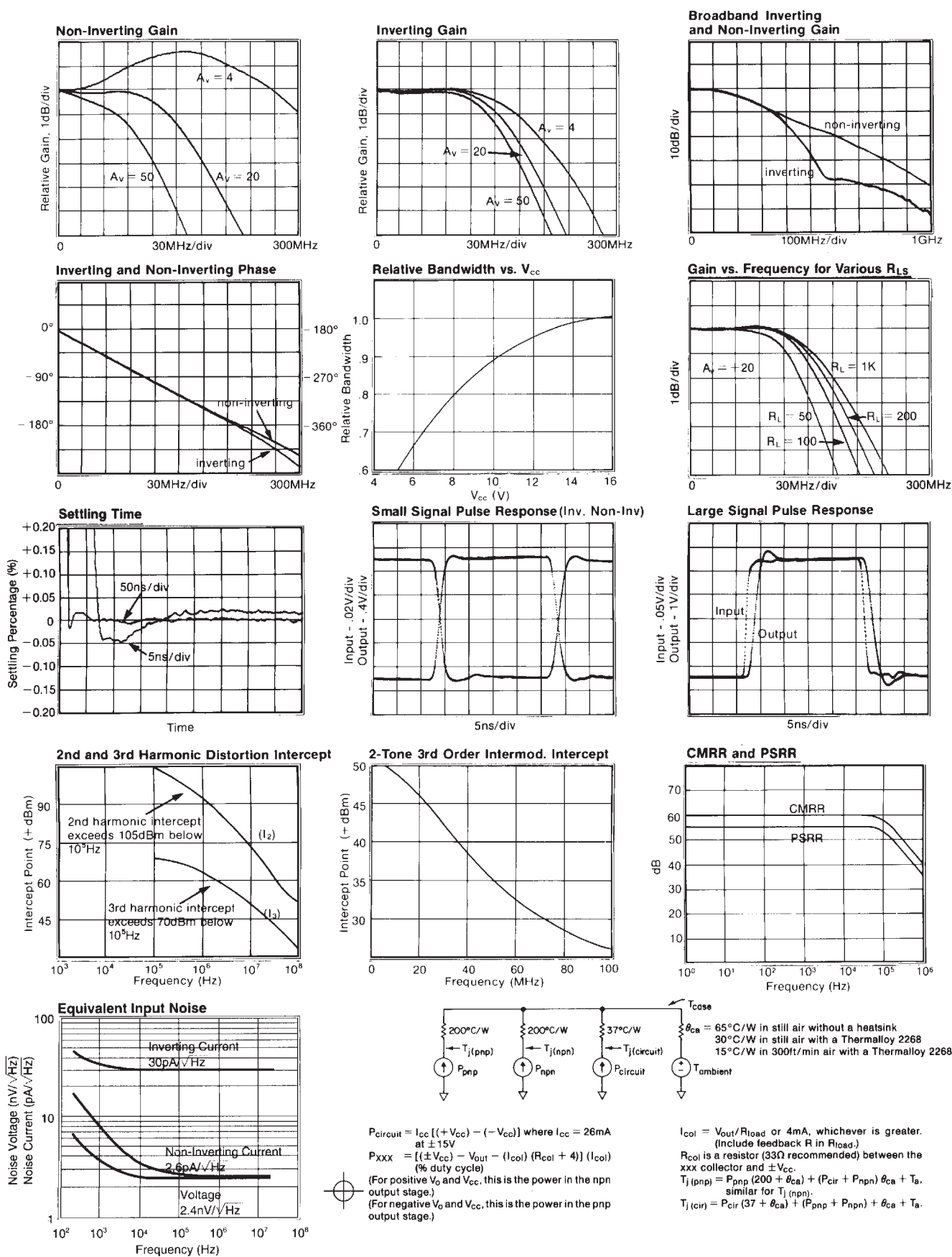

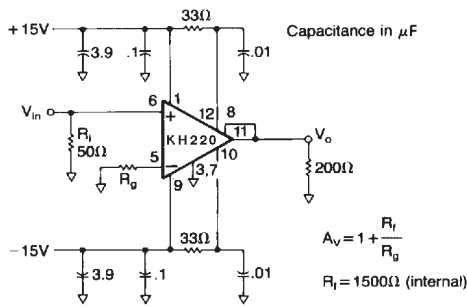

Figure 1: suggested non-inverting gain circuit

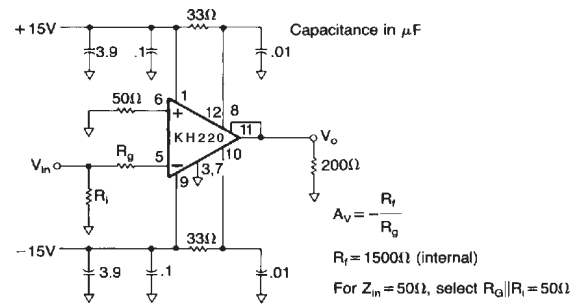

Figure 2: suggested inverting gain circuit

**Controlling Bandwidth and Passband Response**

As with any op amp, the ratio of the two feedback resistors  $R_f$  and  $R_g$  determines the gain of the KH220. Unlike conventional op amps, however, the closed loop pole-zero response of the KH220 is affected very little by the value of  $R_g$ .  $R_g$  scales the magnitude of the gain, but does not change the value of the feedback. This is possible due to a proprietary circuit topology.  $R_f$  does influence the feedback and so the KH220 has been internally compensated for optimum performance with  $R_f = 1500\Omega$ . External  $R_f$  values greater than  $1500\Omega$  can be used with approximate results as listed in Table 1. Use of  $R_f$  values less than  $1500\Omega$  will result in extended bandwidth and peaking of the response at high frequencies. For example,  $R_f = 1000\Omega$  will result in a  $-3\text{dB}$  bandwidth of about  $300\text{MHz}$ , with approximately  $3.5\text{dB}$  of peaking above  $200\text{MHz}$ . An RC network with a  $-3\text{dB}$  bandwidth of about  $250\text{MHz}$  could be used at the input to flatten the response, although it will reduce the bandwidth of the overall circuit.

Table 1: Bandwidth versus  $R_f$

$R_f$ (k $\Omega$ )	$f \pm 0.3\text{dB}$ (MHz)	$f - 3.0\text{dB}$ (MHz)
2	25	80
5	15	30
10	5	15

**Layout Considerations**

To assure optimum performance the user should follow good layout practices which minimize the unwanted coupling of signals between nodes. During initial breadboarding of the circuit, use direct point to point wiring, keeping the lead lengths to less than .25". The use of solid, unbroken ground plane is helpful. Avoid wire-wrap type pc boards and methods. Sockets with small, short pin receptacles may be used with minimal performance degradation although their use is not recommended.

During pc board layout, keep all traces short and direct. The resistive body of  $R_g$  should be as close as possible to pin 5 to minimize capacitance at that point. For the same reason, remove ground plane from the vicinity of pins 5 and 6. In other areas, use as much ground plane as possible on one side of the board. It is especially important to provide a ground return path for current from the load resistor to the power supply bypass capacitors. Ceramic capacitors of .01 to .1 $\mu\text{F}$  (with short leads) should be less than .15 inches from pins 1 and 9. Larger tantalum capacitors should be placed within one inch of these pins.  $V_{cc}$  connections to pins 10 and 12 can be made directly from pins 9 and 1, but better supply rejection and settling time are obtained if they are separately bypassed as in Figures 1 and 2. To prevent signal distortion caused by reflections from impedance mismatches, use terminated microstrip or coaxial cable when the signal must traverse more than a few inches.

Since the pc board forms such an important part of the circuit, much time can be saved if prototype boards of any high frequency sections are built and tested early in the design phase. Evaluation boards designed for either inverting or non-inverting gains are available.

**Thermal Considerations**

At high ambient temperatures or large internal power dissipations, heat sinking is required to maintain acceptable junction temperatures. Use the thermal model on the previous page to determine junction temperatures. Many styles of heat sinks are available for TO-8 packages; the Thermally 2240 and 2268 are good examples. Some heat sinks are the radial fin type which cover the pc board and may interfere with external components. An excellent solution to this problem is to use surface mounted resistors and capacitors. They have a very low profile and actually improve high frequency performance. For use of these heat sinks with conventional components, a .1" high spacer can be inserted under the TO-8 package to allow sufficient clearance.

**Distortion and Amplification Fidelity**

The graphs of intercept point versus frequency on the preceding page make it easy to predict the distortion at any frequency, given the output voltage of the KH220. First, convert the output voltage ( $V_o$ ) to  $V_{RMS} = (V_{pp}/2\sqrt{2})$  and then to  $P = (10\log_{10}(20V_{RMS}^2))$  to get output power in dBm. At the frequency of interest, its 2nd harmonic will be  $S_2 = (I_2 - P)\text{dB}$  below the level of P. Its third harmonic will be  $S_3 = 2(I_3 - P)\text{dB}$  below P, as will the two-tone third order intermodulation products. These approximations are useful for  $P < -1\text{dB}$  compression levels.

Approximate noise figure can be determined for the KH220 using the Equivalent Input Noise graph on the preceding page. The following equation can be used to determine noise figure (F) in dB.

$$F = 10 \log \left[ 1 + \frac{i_n^2 R_f^2}{v_n^2 + A_v^2} \right]$$

where  $v_n$  is the rms noise voltage and  $i_n$  is the rms noise current at the inverting node. Beyond the breakpoint of the curves (i.e., where they are flat), broadband noise figure equals spot noise figure, so  $\Delta f$  should equal one (1) and  $v_n$  and  $i_n$  should be read directly off the graph. Below the breakpoint, the noise must be integrated and  $\Delta f$  set to the appropriate bandwidth.

For linear operation of the KH220 at large output voltage swings (DC component not included) and at high frequencies, observe the (AC output voltage) X (frequency) product specification of  $600V \cdot \text{MHz}$ . Exceeding this rating will cause the signal to be greatly distorted as the amplifier bias control circuit reduces the current available for slewing to prevent damage. At frequencies and voltages within this range the excess slew rate and bandwidth available will ensure the highest possible degree of amplified signal fidelity.

**Operation with Reduced Bias Current**

Placing a resistor between pins 1 and 2 will cause the KH220 bias current to be reduced. A value of  $20\text{K}$  will cause only a slight reduction,  $3\text{K}$  will almost halve the current, while less than  $1\text{K}$  will reduce bias to about  $5\text{mA}$  and the amplifier will be off. In this condition, the input signal will be greatly attenuated. In the reduced bias, on condition, bandwidth will be roughly proportional to the reduction in bias current. A mechanical or semiconductor switch can be used to turn the amplifier off. Any connection which would cause current to flow out of pin 2 will result in increased bias current and may lead to device destruction from overheating and excessive current.

## KH220 Package Dimensions

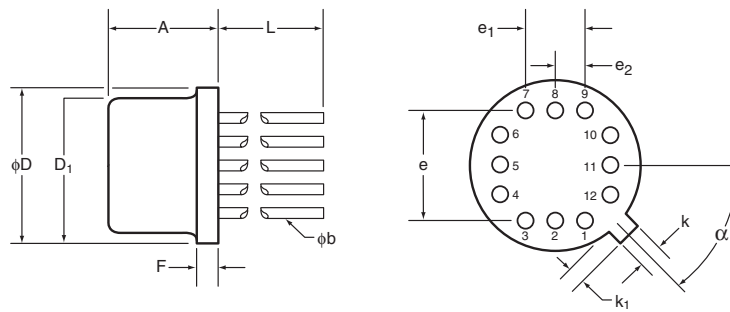

TO-8				
SYMBOL	INCHES		MILIMETERS	
	Minimum	Maximum	Minimum	Maximum
A	0.142	0.181	3.61	4.60
$\phi b$	0.016	0.019	0.41	0.48
$\phi D$	0.595	0.605	15.11	15.37
$\phi D_1$	0.543	0.555	13.79	14.10
e	0.400 BSC		10.16 BSC	
e <sub>1</sub>	0.200 BSC		5.08 BSC	
e <sub>2</sub>	0.100 BSC		2.54 BSC	
F	0.016	0.030	0.41	0.76
k	0.026	0.036	0.66	0.91
k <sub>1</sub>	0.026	0.036	0.66	0.91
L	0.310	0.340	7.87	8.64
$\alpha$	45° BSC		45° BSC	

## NOTES:

Seal: cap weld  
 Lead finish: gold per MIL-M-38510  
 Package composition:  
 Package: metal  
 Lid: Type A per MIL-M-38510

## Life Support Policy

Cadeca's products are not authorized for use as critical components in life support devices or systems without the express written approval of the president of Cadeca Microcircuits, Inc. As used herein:

1. Life support devices or systems are devices or systems which, a) are intended for surgical implant into the body, or b) support or sustain life, and whose failure to perform, when properly used in accordance with instructions for use provided in the labeling, can be reasonably expected to result in a significant injury to the user.
2. A critical component is any component of a life support device or system whose failure to perform can be reasonably expected to cause the failure of the life support device or system, or to affect its safety or effectiveness.

Cadeca does not assume any responsibility for use of any circuitry described, and Cadeca reserves the right at any time without notice to change said circuitry and specifications.