

Three Termination Capacitor Type KGM

ISO 9001:2000
CERTIFIED
TS-16949
CERTIFIED

1. Features

- Surface mount type noise filter
- Plated terminals provide excellent solder resistance
- Small size and high rated DC current
- 0603-2A, 0805-2A, 1206-2A series is available in signal lines in addition to power line

2. Applications

- Noise reduction in high frequency circuits
- D.C. power line
- Vcc line for gate array or microcomputer

3. Ordering & Specifying Information

Type designation shall be as the following form.

| | | | | | | | |
|------------|------------------------------|-------------------------------------|----------------|----------------------|--|--------------------------------------|---------------|
| KGM | 0805 | H | C | T | TE | 220 | 2A |
| Type | Size | Rated Voltage | Temp. Charact. | Termination Material | Packaging | Capacitance | Rated Current |
| | 0603 0805 1206 1812 | C: 16V E: 25V V: 35V H:50V | C F | T: Sn | TE: 7" Embossed Taping 0603: 4,000 pcs/reel 0805: 4,000 pcs/reel 1206: 2,000 pcs/reel 1812: 1,000 pcs/reel | 2 significant figures + No. of zeros | 2A 4A |

4. Dimension and Structure

4.1 Circuit

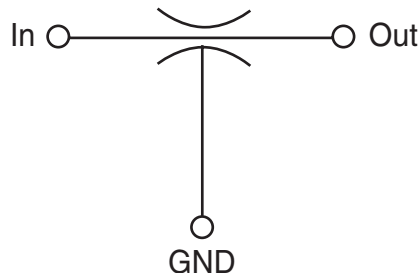

4.2 Dimension

Dimensions in inches (mm)

| Size | L | W | T | g | e |
|------|----------------------|-----------------------|-----------------------|----------------------|-----------------------|
| 0603 | 0.063 (1.6 ± 0.2) | 0.031 (0.8 ± 0.2) | 0.024 (0.6 ± 0.2) | 0.020 (0.5 ± 0.3) | 0.008 (0.2 ± 0.15) |
| 0805 | 0.079 (2.0 ± 0.2) | 0.049 (1.25 ± 0.2) | 0.031 (0.8 ± 0.2*) | 0.016 (0.4 ± 0.3) | 0.012 (0.3 ± 0.2) |
| 1206 | 0.126 (3.2 ± 0.2) | 0.063 (1.6 ± 0.2) | 0.031 (0.8 ± 0.2*) | 0.039 (1.0 ± 0.3) | 0.016 (0.4 ± 0.3) |
| 1812 | 0.177 (4.5 ± 0.3) | 0.126 (3.2 ± 0.3) | 0.039 (1.0 ± 0.2) | 0.039 (1.0 ± 0.3) | 0.016 (0.4 ± 0.3) |

* KGM0805 470
KGM0805 101
KGM0805 220
KGM0805 105
T: 0.035 ± (0.9 ± 0.2)

KGM1206CHT221/2A: T = 0.043 (1.1 ± 0.2)

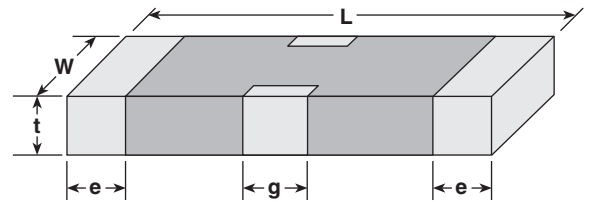

5. Structure

Single Layer Type

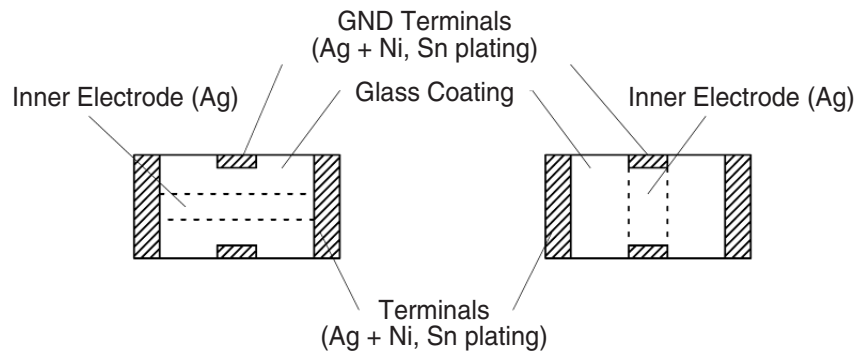

Multilayer Type

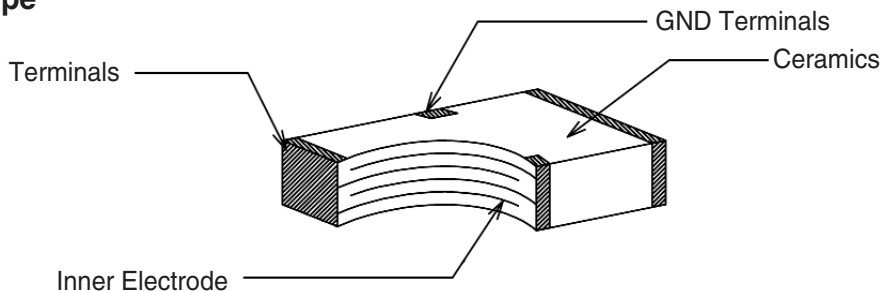

6. Standard Applications

| Part Designation | Capacitance (pF) | Capacitance Tolerance (%) | Rated Voltage DC (V) | Rated Current DC (A) | Insulation Resistance Minimum (MΩ) | Operating Temperature Range |
|-------------------|------------------|---------------------------|----------------------|----------------------|------------------------------------|-----------------------------|
| KGM0603ECTTE2202A | 22 | +50 ~ -20 | 25 | 2 | 1000 | -40°C to +85°C |
| KGM0603ECTTE4702A | 47 | | | | | |
| KGM0603ECTTE1012A | 100 | | | | | |
| KGM0603ECTTE2212A | 220 | | | | | |
| KGM0603ECTTE4712A | 470 | | | | | |
| KGM0603ECTTE1022A | 1000 | | 16 | | | |
| KGM0603CCTTE2222A | 2200 | | | | | |
| KGM0603CCTTE3322A | 3300 | | | | | |
| KGM0603CFTTE2232A | 22,000 | | | | | |
| KGM0603CFTTE1042A | 100,000 | | | | | |
| KGM0805HCTTE2202A | 22 | +50 ~ -20 | 50 | 2 | 1000 | -40°C to +85°C |
| KGM0805HCTTE4702A | 47 | | | | | |
| KGM0805HCTTE1012A | 100 | | | | | |
| KGM0805ECTTE2212A | 220 | | | | | |
| KGM0805ECTTE4712A | 470 | | | | | |
| KGM0805ECTTE1022A | 1000 | | 25 | | | |
| KGM0805ECTTE2222A | 2200 | | | | | |
| KGM0805ECTTE3322A | 3300 | | | | | |
| KGM0805EFTTE1042A | 100,000 | | | | | |
| KGM0805CFTTE1052A | 1,000,000 | | | | | |
| KGM1206HCTTE2202A | 22 | +50 ~ -20 | 50 | 2 | 1000 | -40°C to +85°C |
| KGM1206HCTTE4702A | 47 | | | | | |
| KGM1206HCTTE1012A | 100 | | | | | |
| KGM1206HCTTE2212A | 220 | | | | | |
| KGM1206HCTTE4712A | 470 | | | | | |
| KGM1206HCTTE1022A | 1000 | | 35 | | | |
| KGM1206VCTTE2222A | 2200 | | | | | |
| KGM1206ECTTE2722A | 2700 | | | | | |
| KGM1206ECTTE3322A | 3300 | | | | | |
| KGM1206ECTTE1032A | 10,000 | | | | | |
| KGM1206EFTTE1042A | 100,000 | +50 ~ -20 | 50 | 2 | 1000 | -40°C to +85°C |
| KGM1812HCTTE4714A | 470 | | | | | |
| KGM1812HCTTE1024A | 1000 | | | | | |
| KGM1812HCTTE2224A | 2200 | | 25 | | | |
| KGM1812ECTTE6824A | 6800 | | | | | |

7. Pattern design

The land pattern is recommended as follows.

**0603 Chip
Mounting Side**

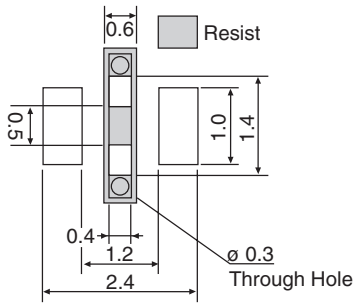

**0805 Chip
Mounting Side**

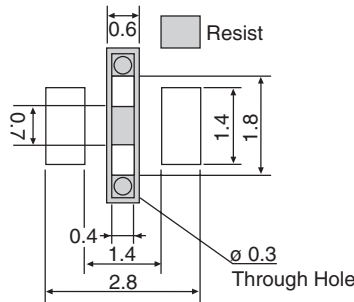

**1206 Chip
Mounting Side**

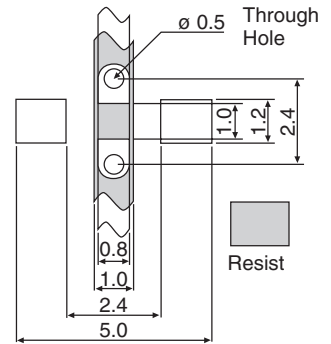

**1812 Chip
Mounting Side**

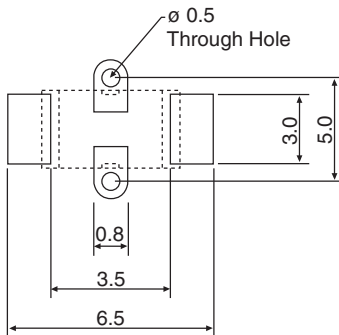

**0603, 0805, 1206,
1812 Back Side**

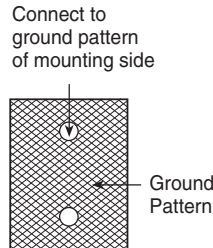

(unit: mm)

8. Characteristics

| Item | Requirement | Conditions |
|----------------------------------|----------------------|---|
| Insulation Resistance | Min 1000M ohms | Applied rated voltage for 60 seconds. |
| Capacitance | Within the tolerance | Frequency: 1kHz Voltage: 1Vrms |
| DC Resistance | Max 60m ohms | DC: 0.3V Max. |
| Dielectric Withstanding Strength | No break down | Applied 250% of the rated voltage for 1 to 5 seconds. Limit surge current 50mA max. |

8. Characteristics Cont.

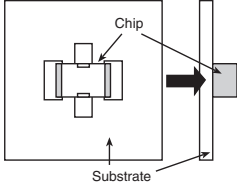
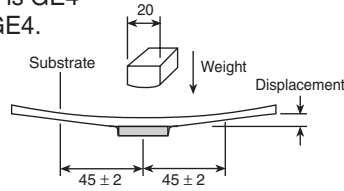
| Item | Requirement | Conditions | | | | | | | | | | | | | | | |
|------------------------------|---|---|------|-------------|------|---|------------|---------------|---|------------|-------------|---|-----------|---------------|---|------------|-------------|
| Terminal Adhesion Strength | No physical damage | Solder a chip to a test substrate and then laterally apply a load (5N, 500gF) in the arrow direction.  | | | | | | | | | | | | | | | |
| Soldering Heat Resistance | Appearance: No physical damage Capacitance: Within tolerance Dielectric Loss: Within tolerance Insulation Resistance: Within tolerance | Flux: 25% rosin Pre-heating: 60 sec Pre-heating Temp: 150°C Solder: H60A Solder Temp: 260°C ±5°C Dip Time: 5 ±0.5 sec | | | | | | | | | | | | | | | |
| Solderability | More than 95% of the terminal electrode shall be covered with new solder. | Flux: 25% rosin Pre-heating: 60 sec Pre-heating Temp: 150°C Solder: H60A Solder Temp: 230°C ±5°C Dip Time: 4 ±1 sec | | | | | | | | | | | | | | | |
| Temperature Cycle | Appearance: No physical damage Capacitance: Within tolerance Dielectric Loss: Within tolerance Insulation Resistance: Within tolerance | Repeat the following heat cycle 10 times: <table border="1" style="margin-left: 40px;"> <thead> <tr> <th>Step</th> <th>Temperature</th> <th>Time</th> </tr> </thead> <tbody> <tr> <td>1</td> <td>-40°C ±3°C</td> <td>30 min ±3 min</td> </tr> <tr> <td>2</td> <td>Room Temp.</td> <td>15 min max.</td> </tr> <tr> <td>3</td> <td>85°C ±2°C</td> <td>30 min ±3 min</td> </tr> <tr> <td>4</td> <td>Room Temp.</td> <td>15 min max.</td> </tr> </tbody> </table> | Step | Temperature | Time | 1 | -40°C ±3°C | 30 min ±3 min | 2 | Room Temp. | 15 min max. | 3 | 85°C ±2°C | 30 min ±3 min | 4 | Room Temp. | 15 min max. |
| Step | Temperature | Time | | | | | | | | | | | | | | | |
| 1 | -40°C ±3°C | 30 min ±3 min | | | | | | | | | | | | | | | |
| 2 | Room Temp. | 15 min max. | | | | | | | | | | | | | | | |
| 3 | 85°C ±2°C | 30 min ±3 min | | | | | | | | | | | | | | | |
| 4 | Room Temp. | 15 min max. | | | | | | | | | | | | | | | |
| High Temperature Resistance | Appearance: No physical damage Capacitance: Within tolerance Dielectric Loss: Within tolerance Insulation Resistance: Within tolerance | Temp: 70°C ±2°C Bias: 150% of rated voltage Test Time: 1000+48/-0 hour | | | | | | | | | | | | | | | |
| Humidity Resistance (unload) | Appearance: No physical damage Capacitance: Within tolerance Dielectric Loss: Within tolerance Insulation Resistance: Within tolerance | Temp: 85°C ±2°C Humidity: 85% ±5% Test Time: 500+24/-0 hour | | | | | | | | | | | | | | | |
| Vending Substrate | Appearance: No physical damage Capacitance: Within tolerance | After soldering a chip to a test substrate, bend the substrate by 1 mm and then measure. The substrate is GE4 or based on GE4.  | | | | | | | | | | | | | | | |

8. Characteristics Cont.

| Item | Requirement | Conditions |
|-------------------------------------|---|--|
| Humidity Resistance (load) | Appearance: No physical damage Capacitance: Within tolerance Dielectric Loss: Within tolerance Insulation Resistance: Within tolerance | Temp: 40°C ±2°C Humidity: 90 - 95% Bias: 100% of rated voltage Test Time: 500+24/-0 hour |
| Low Temperature Resistance (unload) | Appearance: No physical damage Capacitance: Within tolerance Dielectric Loss: Within tolerance Insulation Resistance: Within tolerance | Temp: -40°C ±2°C Test Time: 1000+48/-0 hour |
| Vibration | Appearance: No physical damage Capacitance: Within tolerance Dielectric Loss: Within tolerance Insulation Resistance: Within tolerance | The frequency of applied vibration should be swept from 10 Hz to 55 Hz and return to 10 Hz. This cycle time should be about 1 min and this cycle should be repeated. Amplitude (total Excursion): 1.5 mm This motion shall be applied for period of 2 hours in each 3 mutually perpendicular axes. (total of 6 hours) |

After Temperature cycle test, High temperature resistance test, Humidity resistance test or Low temperature resistance test, the tested sample should be measured after having left in temperature from 15° to 35°C and relative humidity from 45% to 75% for 24 hours.

9. Packaging Specifications

9.1 Taping

Packaging of components on continuous tape is complete with carrier tape for putting components and cover tape for sealing.

(1) Dimensions of Carrier Tape

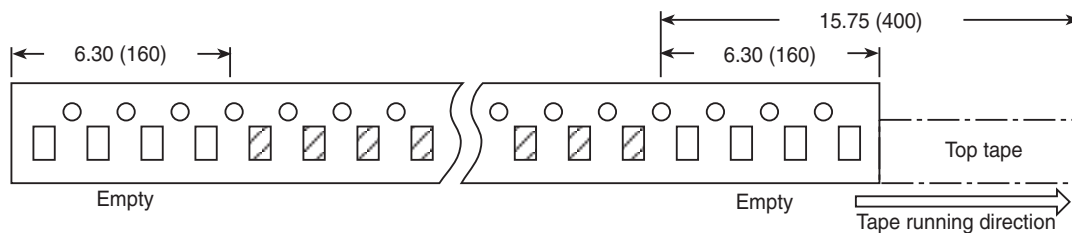

9-1 Taping Cont.

Taping shape in accordance with EIAJ RC-1009B

(2) Dimensions of Embossed Carrier Tape

Dimensions in inches (mm)

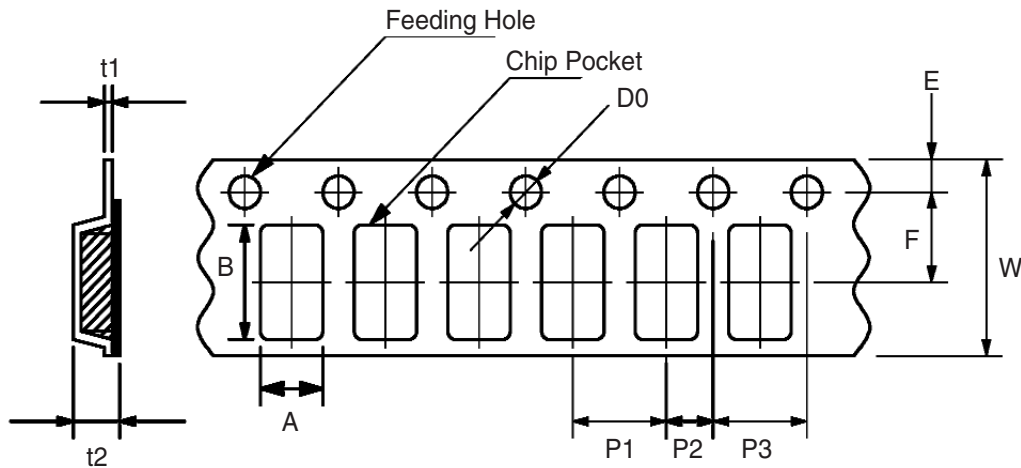

Dimensions in inches (mm)

| Series | A | B | W | F | E | P1 |
|----------------|-------------------------------|-------------------------------|-------------------------------|-------------------------------|-------------------------------|------------------------------|
| KGM0603 Series | 0.043 ± 0.002 (1.1 ± 0.05) | 0.075 ± 0.002 (1.9 ± 0.05) | 0.314 ± 0.003 (8.0 ± 0.1) | 0.137 ± 0.002 (3.5 ± 0.05) | 0.068 ± 0.003 (1.75 ± 0.1) | 0.157 ± 0.003 (4.0 ± 0.1) |
| KGM0805 Series | 0.061 ± 0.003 (1.55 ± 0.1) | 0.091 ± 0.003 (2.3 ± 0.1) | 0.314 ± 0.008 (8.0 ± 0.2) | 0.137 ± 0.002 (3.5 ± 0.05) | 0.068 ± 0.003 (1.75 ± 0.1) | 0.157 ± 0.003 (4.0 ± 0.1) |
| KGM1206 Series | 0.078 ± 0.003 (2.0 ± 0.1) | 0.137 ± 0.003 (3.5 ± 0.1) | 0.314 ± 0.011 (8.0 ± 0.3) | 0.137 ± 0.002 (3.5 ± 0.05) | 0.068 ± 0.003 (1.75 ± 0.1) | 0.157 ± 0.003 (4.0 ± 0.1) |
| KGM1812 Series | 0.137 ± 0.007 (3.5 ± 0.2) | 0.192 ± 0.003 (4.9 ± 0.1) | 0.472 ± 0.011 (12.0 ± 0.3) | 0.216 ± 0.002 (5.5 ± 0.05) | 0.068 ± 0.003 (1.75 ± 0.1) | 0.157 ± 0.003 (4.0 ± 0.1) |

Dimensions in inches (mm)

| Series | P2 | P3 | D0 | t1 | t2 |
|----------------|------------------------------|------------------------------|---|-------------------------------|--------------------|
| KGM0603 Series | 0.078 ± 0.02 (2.0 ± 0.05) | 0.157 ± 0.003 (4.0 ± 0.1) | 0.059 + ^{0.003} / ₋₀ (1.5 + ^{0.1} / ₋₀) | 0.011 ± 0.001 (0.3 ± 0.05) | 0.098 (2.5 max) |
| KGM0805 Series | 0.078 ± 0.02 (2.0 ± 0.05) | 0.157 ± 0.003 (4.0 ± 0.1) | 0.059 + ^{0.003} / ₋₀ (1.5 + ^{0.1} / ₋₀) | 0.011 ± 0.001 (0.3 ± 0.05) | 0.098 (2.5 max) |
| KGM1206 Series | 0.078 ± 0.02 (2.0 ± 0.05) | 0.157 ± 0.003 (4.0 ± 0.1) | 0.059 + ^{0.003} / ₋₀ (1.5 + ^{0.1} / ₋₀) | 0.011 ± 0.001 (0.3 ± 0.05) | 0.098 (2.5 max) |
| KGM1812 Series | 0.078 ± 0.02 (2.0 ± 0.05) | 0.157 ± 0.003 (4.0 ± 0.1) | 0.059 + ^{0.003} / ₋₀ (1.5 + ^{0.1} / ₋₀) | 0.011 ± 0.001 (0.3 ± 0.05) | 0.098 (2.5 max) |

(2) Reel specifications for taping

(3) Standard Packing Quantity

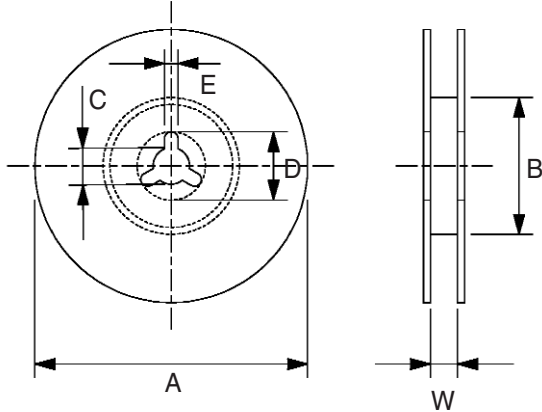

| Series Name | Quantity |
|----------------|----------------|
| KGM0603 Series | 4,000 pcs/reel |
| KGM0805 Series | 4,000 pcs/reel |
| KGM1206 Series | 2,000 pcs/reel |
| KGM1812 Series | 1,000 pcs/reel |

Dimensions in inches (mm)

| Series | A | B | C | D | E | W (min) | W (max) |
|--------|--------------------------|------------------|---|---------------------------|---------------------------|-------------------------------|-------------------------------|
| 0603 | 7.00 ± 0.78 (178 ± 2) | 2.36 (60 min) | 0.511 ^{+0.02} _{-0.008} (13 ^{+0.5} _{-0.2}) | 0.83 ± 0.03 (21 ± 0.8) | 0.079 ± 0.02 (2 ± 0.5) | 0.311 ± 0.059 (7.9 ± 1.5) | 0.429 ± 0.059 (10.9 ± 1.5) |
| 0805 | | | | | | | — |
| 1206 | | | | | | 0.468 ± 0.059 (11.9 ± 1.5) | 0.606 ± 0.059 (15.4 ± 1.5) |
| 1812 | | | | | | | |

10. Soldering

KOA filters have Ag (or Ag-Pd) Ni barrier terminals, overplated with Sn for use in either wave or reflow soldering processes.

Ceramics are very sensitive in general to thermal shock. Therefore KOA filters should not be exposed to sudden temperature increases or partial heating.

Prior to soldering, KOA filters shall be preheated so that the temperature difference during soldering will be kept within 130°C.

It is desirable that soldering temperature be kept to 240 ~ 250°C and soldering time be within 4 seconds.

Flux shall be Rosin type. Do not use strong acid type fluxes.

The tip of soldering iron should be 20 W. 3 mmø maximum.

The tip of soldering iron should be 220 - 250°C maximum. Care must be taken not to physically damage the chip through abnormal contact with soldering irons.