

ASCEND

Semiconductor

4Mx4 EDO

Data sheet

AD 40 4M 4 2 V S A - 5

Ascend
Semiconductor

EDO/FPM : 40
D-RAMBUS : 41
DDRSDRAM : 42
DDRSGRAM : 43
SGRAM : 46
SDRAM : 48

Density

16M : 16 Mega Bits
8M : 8 Mega Bits
4M : 4 Mega Bits
2M : 2 Mega Bits
1M : 1 Mega Bit

Organization

4: x4
8 : x8
9 : x9
16 : x16
18 : x18
32 : x32

Refresh

1 : 1K 8 : 8K
2 : 2K 6 : 16K
4 : 4K

Interface

V: 3.3V
R: 2.5V

Min Cycle Time (Max Freq.)

-5 : 5ns (200MHz)
-6 : 6ns (167MHz)
-7 : 7ns (143MHz)
-7.5 : 7.5ns (133MHz)
-8 : 8ns (125MHz)
-10 : 10ns (100MHz)

EDO : -5 (50 ns)
-6 (60 ns)

Revision

A : 1st B : 2nd
C : 3rd D : 4th

Package

C: CSP B: uBGA
T: TSOP Q: TQFP
P: PQFP (QFP)
L: LQFP S: SOJ



Description

The device CMOS Dynamic RAM organized as 4,194,304 words x 4 bits with extended data out access mode. It is fabricated with an advanced submicron CMOS technology and designed to operate from a single 3.3V only power supply. Low voltage operation is more suitable to be used on battery backup, portable electronic application. It is packaged in JEDEC standard 26/24-pin plastic SOJ or TSOP(II).

Features

- Single 3.3V($\pm 10\%$) only power supply
- High speed t_{RAC} access time: 50/60ns
- Low power dissipation
 - Active mode : 432/396 mW (Mas)
 - Standby mode: 0.54 mW (Mas)
- Extended - data - out(EDO) page mode access
- I/O level: CMOS level ($V_{cc} = 3.3V$)
- 2048 refresh cycle in 32 ms(Std.) or 128 ms(S-version)
- 4 refresh modes:
 - \overline{RAS} only refresh
 - CAS - before - \overline{RAS} refresh
 - Hidden refresh
 - Self-refresh(S-version)

EEPW.com.cn 电子产品世界

Pin Configuration

26/24-PIN 300mil Plastic SOJ

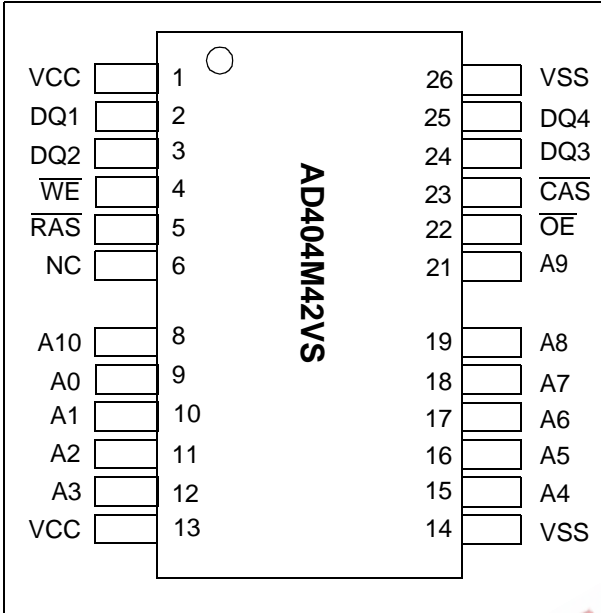

26/24-PIN 300mil Plastic TSOP (II)

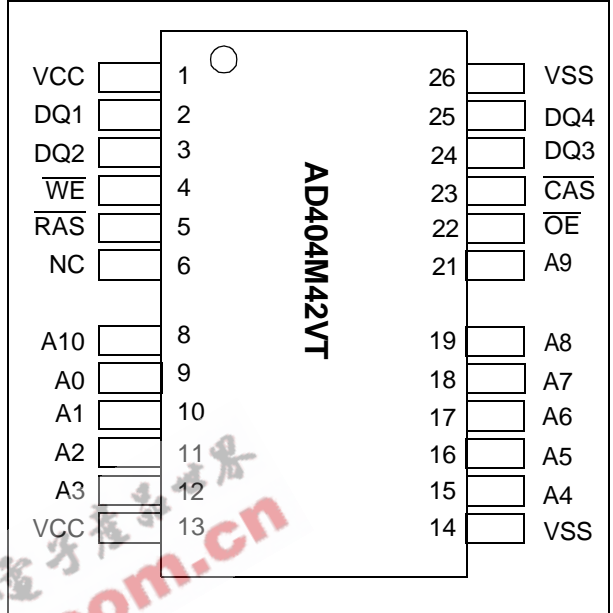

Pin Description

| Pin Name | Function |
|----------|---|
| A0-A10 | Address inputs - Row address A0-A10 - Column address A0-A10 - Refresh address A0-A10 |
| DQ1~DQ4 | Data-in / data-out |
| RAS | Row address strobe |
| CAS | Column address strobe |
| WE | Write enable |
| OE | Output enable |
| Vcc | Power (+ 3.3V) |
| Vss | Ground |

Block Diagram



TRUTH TABLE

| FUNCTION | | $\overline{\text{RAS}}$ | $\overline{\text{CAS}}$ | $\overline{\text{WE}}$ | $\overline{\text{OE}}$ | ADDRESSES | | DQ _S | Notes |
|--------------------------|-----------|-------------------------|-------------------------|------------------------|------------------------|-----------|-----|-------------------|-------|
| | | | | | | ROW | COL | | |
| STANDBY | | H | H → X | X | X | X | X | High-Z | |
| READ | | L | L | H | L | ROW | COL | Data-Out | |
| WRITE: (EARLY WRITE) | | L | L | L | X | ROW | COL | Data-In | |
| READ WRITE | | L | L | H → L | L → H | ROW | COL | Data-Out, Data-In | |
| EDO-PAGE-MODE READ | 1st Cycle | L | H → L | H | L | ROW | COL | Data-Out | |
| | 2nd Cycle | L | H → L | H | L | n/a | COL | Data-Out | |
| EDO-PAGE MODE WRITE | 1st Cycle | L | H → L | L | X | ROW | COL | Data-In | |
| | 2nd Cycle | L | H → L | L | X | n/a | COL | Data-In | |
| EDO-PAGE-MODE READ-WRITE | 1st Cycle | L | H → L | H → L | L → H | ROW | COL | Data-Out, Data-In | |
| | 2nd Cycle | L | H → L | H → L | L → H | n/a | COL | Data-Out, Data-In | |
| HIDDEN REFRESH | READ | L → H → L | L | H | L | ROW | COL | Data-Out | |
| | WRITE | L → H → L | L | L | X | ROW | COL | Data-In | 1 |
| RAS-ONLY REFRESH | | L | H | X | X | ROW | n/a | High-Z | |
| CBR REFRESH | | H → L | L | H | X | X | X | High-Z | |

Notes: 1. EARLY WRITE only.

Absolute Maximum Ratings

| Parameter | Symbol | Value | Unit |
|--|------------------|---------------|------|
| Voltage on any pin relative to V _{SS} | V _T | -0.5 to + 4.6 | V |
| Supply voltage relative to V _{SS} | V _{CC} | -0.5 to + 4.6 | V |
| Short circuit output current | I _{OUT} | 50 | mA |
| Power dissipation | P _D | 1.0 | W |
| Operating temperature | T _{OPT} | 0 to + 70 | °C |
| Storage temperature | T _{STG} | -55 to + 125 | °C |

Recommended DC Operating Conditions

| Parameter/Condition | Symbol | 3.3 Volt Version | | | Unit |
|--------------------------------|-----------------|------------------|-----|-----------------------|------|
| | | Min | Typ | Max | |
| Supply Voltage | V _{CC} | 3.0 | 3.3 | 3.6 | V |
| Input High Voltage, all inputs | V _{IH} | 2.0 | - | V _{CC} + 0.3 | V |
| Input Low Voltage, all inputs | V _{IL} | -0.3 | - | -0.8 | V |

Capacitance

T_a = 25°C, V_{CC} = 3.3V ±10 %, f = 1MHz

| Parameter | Symbol | Typ | Max | Unit | Note |
|---|------------------|-----|-----|------|------|
| Input capacitance (Address) | C _{I1} | - | 5 | pF | 1 |
| Input capacitance ($\overline{\text{RAS}}$, $\overline{\text{CAS}}$, $\overline{\text{OE}}$, $\overline{\text{WE}}$) | C _{I2} | - | 7 | pF | 1 |
| Output capacitance (Data-in, Data-out) | C _{I/O} | - | 7 | pF | 1, 2 |

Note: 1. Capacitance measured with effective capacitance measuring method.

2. RAS, CAS = V_{IH} to disable Dout.

DC Characteristics :

($T_a = 0$ to 70°C , $V_{CC} = + 3.3\text{V} \pm 10\%$, $V_{SS} = 0\text{V}$)

| Parameter | | Symbol | Test Conditions | AD404M42V | | | | Unit | Notes |
|-----------------------------------|------------------------|-----------|---|-----------|------|-----|------|---------------|-------|
| | | | | -5 | | -6 | | | |
| | | | | Min | Max | Min | Max | | |
| Operating current | | I_{CC1} | $\overline{\text{RAS}}$ cycling CAS, cycling $t_{RC} = \text{min}$ | - | 120 | - | 110 | mA | 1, 2 |
| Standby Current | Low power S-version | I_{CC2} | LVTTTL interface RAS, CAS = V_{IH} Dout = High-Z | - | 0.5 | - | 0.5 | mA | |
| | | | CMOS interface $\overline{\text{RAS}}, \overline{\text{CAS}} \geq V_{CC} - 0.2\text{V}$ Dout = High-Z | - | 0.15 | - | 0.15 | mA | |
| | Standard power version | I_{CC2} | LVTTTL interface RAS, CAS = V_{IH} Dout = High-Z | - | 2 | - | 2 | mA | |
| | | | CMOS interface $\overline{\text{RAS}}, \overline{\text{CAS}} \geq V_{CC} - 0.2\text{V}$ Dout = High-Z | - | 0.5 | - | 0.5 | mA | |
| RAS- only refresh current | | I_{CC3} | $\overline{\text{RAS}}$ cycling, $\overline{\text{CAS}} = V_{IH}$ $t_{RC} = \text{min}$ | - | 120 | - | 110 | mA | 1, 2 |
| EDO page mode current | | I_{CC4} | $t_{PC} = \text{min}$ | - | 90 | - | 80 | mA | 1, 3 |
| CAS- before- RAS refresh current | | I_{CC5} | $t_{RC} = \text{min}$ RAS, CAS cycling | - | 120 | - | 110 | mA | 1, 2 |
| Self- refresh current (S-Version) | | I_{CC8} | $t_{RASS} \geq 100\mu\text{s}$ | - | 550 | - | 550 | μA | |

DC Characteristics :(T_a = 0 to 70°C, V_{CC} = +3.3V ±10%, V_{SS} = 0V)

| Parameter | Symbol | Test Conditions | AD404M42V | | | | Unit | Notes |
|------------------------|-----------------|--|-----------|-----|-----|-----|------|-------|
| | | | -5 | | -6 | | | |
| | | | Min | Max | Min | Max | | |
| Input leakage current | I _{LI} | 0V ≤ V _{in} ≤ V _{CC} + 0.3V | -5 | 5 | -5 | 5 | μA | |
| Output leakage current | I _{LO} | 0V ≤ V _{out} ≤ V _{CC} + 0.3V Dout = Disable | -5 | 5 | -5 | 5 | μA | |
| Output high Voltage | V _{OH} | I _{OH} = -2mA | 2.4 | - | 2.4 | - | V | |
| Output low voltage | V _{OL} | I _{OL} = +2mA | - | 0.4 | - | 0.4 | V | |

Notes:

1. I_{CC} is specified as an average current. It depends on output loading condition and cycle rate when the device is selected. I_{CC} max is specified at the output open condition.
2. Address can be changed once or less while $\overline{\text{RAS}} = V_{\text{IL}}$.
3. For I_{CC4}, address can be changed once or less within one EDO page mode cycle time.

AC Characteristics

($T_a = 0$ to $+70^\circ\text{C}$, $V_{CC} = 3.3\text{V} \pm 10\%$, $V_{SS} = 0\text{V}$) *1, *2, *3, *4

Test conditions

- Output load: one TTL Load and 100pF ($V_{CC} = 3.3\text{V} \pm 10\%$)
- Input timing reference levels:
 $V_{IH} = 2.0\text{V}$, $V_{IL} = 0.8\text{V}$ ($V_{CC} = 3.3\text{V} \pm 10\%$)
- Output timing reference levels:
 $V_{OH} = 2.0\text{V}$, $V_{OL} = 0.8\text{V}$

Read, Write, Read- Modify- Write and Refresh Cycles

(Common Parameters)

| Parameter | Symbol | AD404M42V | | | | Unit | Notes |
|---|-----------|-----------|-------|-----|-------|------|-------|
| | | -5 | | -6 | | | |
| | | Min | Max | Min | Max | | |
| Random read or write cycle time | t_{RC} | 84 | - | 104 | - | ns | |
| $\overline{\text{RAS}}$ precharge time | t_{RP} | 30 | - | 40 | - | ns | |
| $\overline{\text{CAS}}$ precharge time in normal mode | t_{CPN} | 10 | - | 10 | - | ns | |
| $\overline{\text{RAS}}$ pulse width | t_{RAS} | 50 | 10000 | 60 | 10000 | ns | 5 |
| $\overline{\text{CAS}}$ pulse width | t_{CAS} | 8 | 10000 | 10 | 10000 | ns | 6 |
| Row address setup time | t_{ASR} | 0 | - | 0 | - | ns | |
| Row address hold time | t_{RAH} | 8 | - | 10 | - | ns | |
| Column address setup time | t_{ASC} | 0 | - | 0 | - | ns | 7 |
| Column address hold time | t_{CAH} | 8 | - | 10 | - | ns | |
| $\overline{\text{RAS}}$ to $\overline{\text{CAS}}$ delay time | t_{RCD} | 12 | 37 | 14 | 45 | ns | 8 |
| $\overline{\text{RAS}}$ to column address delay time | t_{RAD} | 10 | 25 | 12 | 30 | ns | 9 |
| Column address to $\overline{\text{RAS}}$ lead time | t_{RAL} | 25 | - | 30 | - | ns | |
| $\overline{\text{RAS}}$ hold time | t_{RSH} | 8 | - | 10 | - | ns | |
| $\overline{\text{CAS}}$ hold time | t_{CSH} | 38 | - | 40 | - | ns | |
| $\overline{\text{CAS}}$ to $\overline{\text{RAS}}$ precharge time | t_{CRP} | 5 | - | 5 | - | ns | 10 |
| $\overline{\text{OE}}$ to Din delay time | t_{OED} | 12 | - | 15 | - | ns | |
| Transition time (rise and fall) | t_T | 1 | 50 | 1 | 50 | ns | 11 |
| Refresh period | t_{REF} | - | 32 | - | 32 | ms | |
| Refresh period (S- Version) | t_{REF} | - | 128 | - | 128 | ms | |
| $\overline{\text{CAS}}$ to output in Low- Z | t_{CLZ} | 0 | - | 0 | - | ns | |
| $\overline{\text{CAS}}$ delay time from Din | t_{DZC} | 0 | - | 0 | - | ns | |
| $\overline{\text{OE}}$ delay time from Din | t_{DZO} | 0 | - | 0 | - | ns | |

Read Cycle

| Parameter | Symbol | AD404M42V | | | | Unit | Notes |
|---|------------------|-----------|-----|-----|-----|------|--------|
| | | -5 | | -6 | | | |
| | | Min | Max | Min | Max | | |
| Access time from $\overline{\text{RAS}}$ | t_{RAC} | - | 50 | - | 60 | ns | 12 |
| Access time from $\overline{\text{CAS}}$ | t_{CAC} | - | 14 | - | 15 | ns | 13, 14 |
| Access time from column address | t_{AA} | - | 25 | - | 30 | ns | 14, 15 |
| Access time from $\overline{\text{OE}}$ | t_{OEA} | - | 12 | - | 15 | ns | |
| Read command setup time | t_{RCS} | 0 | - | 0 | - | ns | 7 |
| Read command hold time to $\overline{\text{CAS}}$ | t_{RCH} | 0 | - | 0 | - | ns | 10, 16 |
| Read command hold time to $\overline{\text{RAS}}$ | t_{RRH} | 0 | - | 0 | - | ns | 16 |
| Output buffer turn-off time | t_{OFF} | 0 | 12 | 0 | 15 | ns | 17 |
| Output buffer turn-off time from $\overline{\text{OE}}$ | t_{OEZ} | 0 | 12 | 0 | 15 | ns | 17 |

Write Cycle

| Parameter | Symbol | AD404M42V | | | | Unit | Notes |
|--|------------------|-----------|-----|-----|-----|------|-------|
| | | -5 | | -6 | | | |
| | | Min | Max | Min | Max | | |
| Write command setup time | t_{WCS} | 0 | - | 0 | - | ns | 7, 18 |
| Write command hold time | t_{WCH} | 8 | - | 10 | - | ns | |
| Write command pulse width | t_{WP} | 8 | - | 10 | - | ns | |
| Write command to $\overline{\text{RAS}}$ lead time | t_{RWL} | 13 | - | 15 | - | ns | |
| Write command to $\overline{\text{CAS}}$ lead time | t_{CWL} | 8 | - | 10 | - | ns | |
| Data-in setup time | t_{DS} | 0 | - | 0 | - | ns | 19 |
| Data-in hold time | t_{DH} | 8 | - | 10 | - | ns | 19 |
| $\overline{\text{WE}}$ to Data-in delay | t_{WED} | 10 | - | 10 | - | ns | |

Read- Modify- Write Cycle

| Parameter | Symbol | AD404M42V | | | | Unit | Notes |
|--|-----------|-----------|-----|-----|-----|------|-------|
| | | -5 | | -6 | | | |
| | | Min | Max | Min | Max | | |
| Read-modify- write cycle time | t_{RWC} | 108 | - | 133 | - | ns | |
| \overline{RAS} to \overline{WE} delay time | t_{RWD} | 64 | - | 77 | - | ns | 18 |
| \overline{CAS} to \overline{WE} dealy time | t_{CWD} | 26 | - | 32 | - | ns | 18 |
| Column address to \overline{WE} delay time | t_{AWD} | 39 | - | 47 | - | ns | 18 |
| \overline{OE} hold time from \overline{WE} | t_{OEH} | 8 | - | 10 | - | ns | |

Refresh Cycle

| Parameter | Symbol | AD404M42V | | | | Unit | Notes |
|--|------------|-----------|-----|-----|-----|---------|-------|
| | | -5 | | -6 | | | |
| | | Min | Max | Min | Max | | |
| \overline{CAS} setup time (CBR refresh) | t_{CSR} | 5 | - | 5 | - | ns | |
| \overline{CAS} hold time (CBR refresh) | t_{CHR} | 8 | - | 10 | - | ns | 10 |
| \overline{RAS} precharge to \overline{CAS} hold time | t_{RPC} | 5 | - | 5 | - | ns | 7 |
| \overline{RAS} pulse width (self refresh) | t_{RASS} | 100 | - | 100 | - | μs | |
| \overline{RAS} precharge time (self refresh) | t_{RPS} | 90 | - | 110 | - | ns | |
| \overline{CAS} hold time (CBR self refresh) | t_{CHS} | -50 | - | -50 | - | ns | |
| \overline{WE} setup time | t_{WSR} | 0 | - | 0 | - | ns | |
| \overline{WE} hold time | t_{WHR} | 10 | - | 10 | - | ns | |

EDO Page Mode Cycle

| Parameter | Symbol | AD404M42V | | | | Unit | Notes |
|---|------------|-----------|--------|-----|--------|------|--------|
| | | -5 | | -6 | | | |
| | | Min | Max | Min | Max | | |
| EDO page mode cycle time | t_{PC} | 20 | - | 25 | - | ns | |
| EDO page mode \overline{CAS} precharge time | t_{CP} | 10 | - | 10 | - | ns | |
| EDO page mode \overline{RAS} pulse width | t_{RASP} | 50 | 10^5 | 60 | 10^5 | ns | 20 |
| Access time from \overline{CAS} precharge | t_{CPA} | - | 30 | - | 35 | ns | 10, 14 |
| \overline{RAS} hold time from \overline{CAS} precharge | t_{CPRH} | 30 | - | 35 | - | ns | |
| \overline{OE} high hold time from \overline{CAS} high | t_{OEHC} | 5 | - | 5 | - | ns | |
| \overline{OE} high pulse width | t_{OEP} | 10 | - | 10 | - | ns | |
| Data output hold time after \overline{CAS} low | t_{COH} | 5 | - | 5 | - | ns | |
| Output disable delay from \overline{WE} | t_{WHZ} | 3 | 10 | 3 | 10 | ns | |
| \overline{WE} pulse width for output disable when \overline{CAS} high | t_{WPZ} | 7 | - | 7 | - | ns | |

EDO Page Mode Read Modify Write Cycle

| Parameter | Symbol | AD404M42V | | | | Unit | Notes |
|--|------------|-----------|-----|-----|-----|------|-------|
| | | -5 | | -6 | | | |
| | | Min | Max | Min | Max | | |
| EDO page mode read- modify- write cycle \overline{CAS} precharge to \overline{WE} delay time | t_{CPW} | 45 | - | 55 | - | ns | 10 |
| EDO page mode read- modify- write cycle time | t_{PRWC} | 56 | - | 68 | - | ns | |

Notes :

1. AC measurements assume $t_T = 2\text{ns}$.
2. An initial pause of $100\ \mu\text{s}$ is required after power up, and it followed by a minimum of eight initialization cycles ($\overline{\text{RAS}}$ - only refresh cycle or $\overline{\text{CAS}}$ - before - $\overline{\text{RAS}}$ refresh cycle). If the internal refresh counter is used, a minimum of eight $\overline{\text{CAS}}$ - before - $\overline{\text{RAS}}$ refresh cycles are required.
3. In delayed write or read-modify-write cycles, $\overline{\text{OE}}$ must disable output buffer prior to applying data to the device.
4. All the V_{CC} and V_{SS} pins shall be supplied with the same voltages.
5. $t_{\text{RAS}}(\text{min}) = t_{\text{RWD}}(\text{min}) + t_{\text{RWL}}(\text{min}) + t_T$ in read-modify-write cycle.
6. $t_{\text{CAS}}(\text{min}) = t_{\text{CWD}}(\text{min}) + t_{\text{CWL}}(\text{min}) + t_T$ in read-modify-write cycle.
7. $t_{\text{ASC}}(\text{min})$, $t_{\text{RCS}}(\text{min})$, $t_{\text{WCS}}(\text{min})$, and t_{RPC} are determined by the falling edge of $\overline{\text{CAS}}$.
8. $t_{\text{RCD}}(\text{max})$ is specified as a reference point only, and $t_{\text{RAC}}(\text{max})$ can be met with the $t_{\text{RCD}}(\text{max})$ limit. Otherwise, t_{RAC} is controlled exclusively by t_{CAC} if t_{RCD} is greater than the specified $t_{\text{RCD}}(\text{max})$ limit.
9. $t_{\text{RAD}}(\text{max})$ is specified as a reference point only, and $t_{\text{RAC}}(\text{max})$ can be met with the $t_{\text{RAD}}(\text{max})$ limit. Otherwise, t_{RAC} is controlled exclusively by t_{AA} if t_{RAD} is greater than the specified $t_{\text{RAD}}(\text{max})$ limit.
10. t_{CRP} , t_{CHR} , t_{RCH} , t_{CPA} and t_{CPW} are determined by the rising edge of $\overline{\text{CAS}}$.
11. $V_{\text{IH}}(\text{min})$ and $V_{\text{IL}}(\text{max})$ are reference levels for measuring timing or input signals. Therefore, transition time is measured between V_{IH} and V_{IL} .
12. Assumes that $t_{\text{RCD}} \leq t_{\text{RCD}}(\text{max})$ and $t_{\text{RAD}} \leq t_{\text{RAD}}(\text{max})$. If t_{RCD} or t_{RAD} is greater than the maximum recommended value shown in this table, t_{RAC} exceeds the value shown.
13. Assumes that $t_{\text{RCD}} \geq t_{\text{RCD}}(\text{max})$ and $t_{\text{RAD}} \leq t_{\text{RAD}}(\text{max})$.
14. Access time is determined by the maximum of t_{AA} , t_{CAC} , t_{CPA} .
15. Assumes that $t_{\text{RCD}} \leq t_{\text{RCD}}(\text{max})$ and $t_{\text{RAD}} \geq t_{\text{RAD}}(\text{max})$.
16. Either t_{RCH} or t_{RRH} must be satisfied for a read cycle.
17. $t_{\text{OFF}}(\text{max})$ and $t_{\text{OEZ}}(\text{max})$ define the time at which the output achieves the open circuit condition (high impedance). t_{OFF} is determined by the later rising edge of $\overline{\text{RAS}}$ or $\overline{\text{CAS}}$.
18. t_{WCS} , t_{RWD} , t_{CWD} , and t_{AWD} are not restrictive operating parameters. They are included in the data sheet as electrical characteristics only. If $t_{\text{WCS}} \geq t_{\text{WCS}}(\text{min})$, the cycle is an early write cycle and the data out will remain open circuit (high impedance) throughout the entire cycle. If $t_{\text{RWD}} \geq t_{\text{RWD}}(\text{min})$, $t_{\text{CWD}} \geq t_{\text{CWD}}(\text{min})$, $t_{\text{AWD}} \geq t_{\text{AWD}}(\text{min})$ and $t_{\text{CPW}} \geq t_{\text{CPW}}(\text{min})$, the cycle is a read-modify-write and the data output will contain data read from the selected cell. If neither of the above sets of conditions is satisfied, the condition of the data output (at access time) is indeterminate.
19. These parameters are referenced to $\overline{\text{CAS}}$ separately in an early write cycle and to $\overline{\text{WE}}$ edge in a delayed write or a read-modify-write cycle.
20. t_{RASP} defines $\overline{\text{RAS}}$ pulse width in EDO page mode cycles.

Timing Waveforms
• Read Cycle



•Early Write Cycle

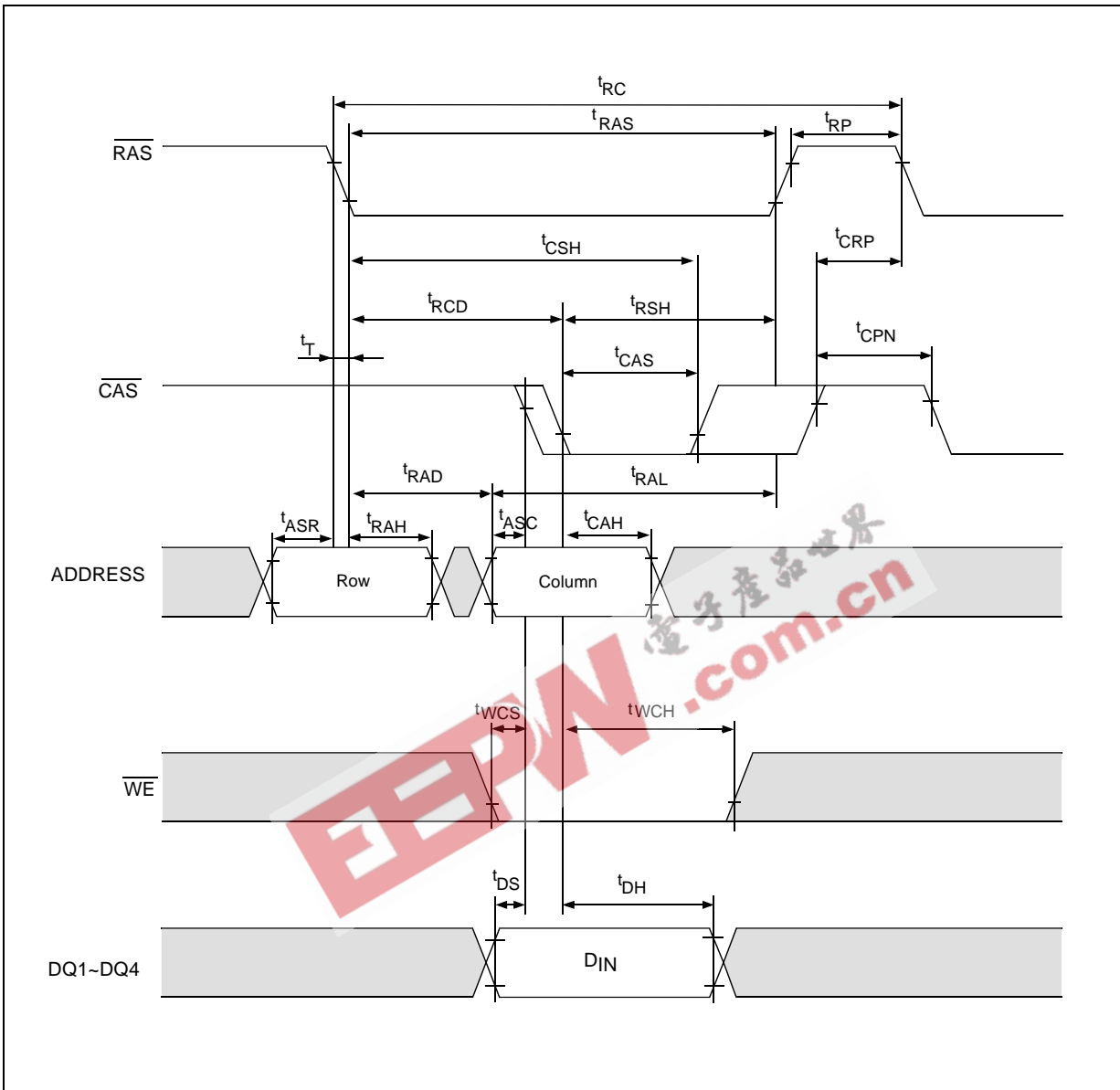

• Delayed Write Cycle



• Read - Modify - Write Cycle



• EDO Page Mode Read Cycle

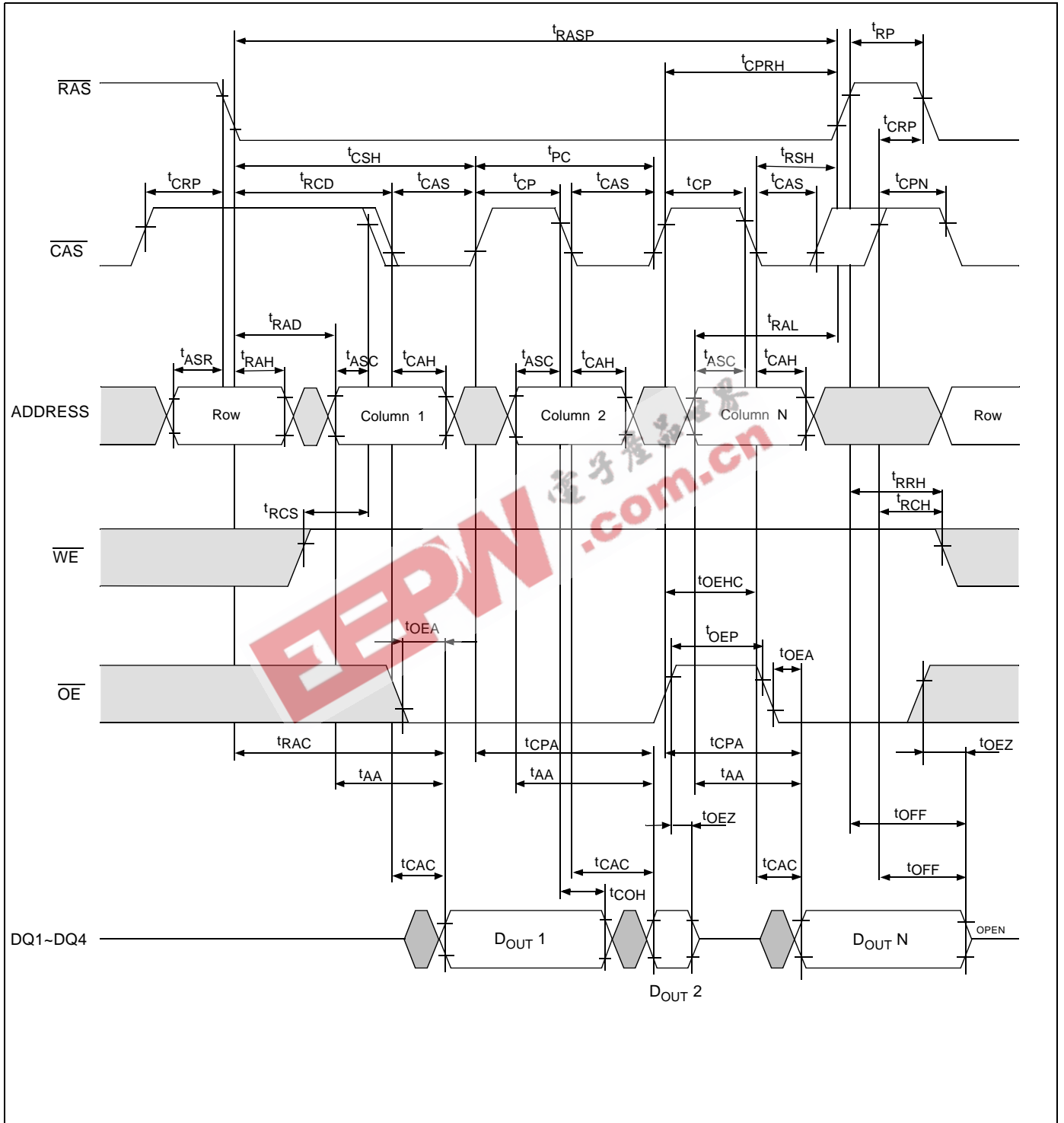

• EDO Page Mode Early Write Cycle



• EDO Page Mode Read-Early-Write Cycle



• EDO Page Mode Read-Modify-Write Cycle



• Read Cycle with \overline{WE} Controlled Disable



RAS-Only Refresh Cycle



CAS-Before-RAS Refresh Cycle



CBR Self-Refresh Cycle



• Hidden Refresh Cycle



Ordering information

| Part Number | Access time | Package |
|---------------|-------------|------------------------|
| AD404M42VSA-5 | 50 ns | 300mil 26/24-Pin |
| AD404M42VSA-6 | 60 ns | |
| AD404M42VTA-5 | 50 ns | Plastic SOJ TSOP II |
| AD404M42VTA-6 | 60 ns | |

AD404M42VSA-5

- AD → • Ascend Memory Product
- 40 → • Device Type
- 4M4 → • Density and Organization
- 2 → • Refresh Rate, 2: 2K Refresh
- V → • T: 5V, V: 3.3V
- S → • Package Type (S : SOJ, T : TSOP II)
- A → • Version
- 5 → • Speed (5: 50 ns, 6: 60 ns)

Packaging information

- 300 mil, 26/24-Pin Plastic SOJ



• 300 mil, 26/24-Pin TSOP II

| DIM | MILLIMETERS | | | INCHES | | |
|-----|-------------|-------|-------|--------------|-------|---------|
| | MIN. | NOM. | MAX. | MIN. | NOM. | MAX. |
| A | --- | --- | 1.20 | --- | --- | 0.047 |
| A1 | 0.05 | --- | 0.15 | 0.002 | --- | 0.006 |
| A2 | 0.95 | 1.00 | 1.05 | 0.037 | 0.039 | 0.041 |
| b | 0.30 | --- | 0.52 | 0.012 | --- | 0.020 |
| b1 | 0.30 | 0.40 | 0.45 | 0.012 | 0.016 | 0.018 |
| c | 0.12 | --- | 0.21 | 0.005 | --- | 0.008 |
| c1 | 0.12 | 0.15 | 0.16 | 0.005 | 0.006 | (0.006) |
| D | 17.01 | 17.14 | 17.27 | 0.670 | 0.675 | 0.680 |
| ZD | 0.95 REF. | | | 0.0374 BASIC | | |
| e | 1.27 BASIC | | | 0.050 BASIC | | |
| E | 9.02 | 9.22 | 9.42 | 0.355 | 0.363 | 0.371 |
| E1 | 7.49 | 7.62 | 7.75 | 0.295 | 0.300 | 0.305 |
| L | 0.40 | 0.50 | 0.60 | 0.016 | 0.020 | 0.024 |
| R | 0.12 | --- | 0.25 | 0.005 | --- | 0.010 |
| R1 | 0.12 | --- | --- | 0.005 | --- | --- |



NOTE:

- CONTROLLING DIMENSION : MILLIMETERS
- DIMENSION D DOES NOT INCLUDE MOLD PROTRUSION.
MOLD PROTRUSION SHALL NOT EXCEED 0.15(0.006") PER SIDE.
DIMENSION E1 DOES NOT INCLUDE INTERLEAD PROTRUSION.
INTERLEAD PROTRUSION SHALL NOT EXCEED 0.25(0.01") PER SIDE.
- DIMENSION b DOES NOT INCLUDE DAMBAR PROTRUSIONS/INTRUSION.
ALLOWABLE DAMBAR PROTRUSION SHALL NOT CAUSE THE LEAD TO BE WIDER THAN THE MAX b DIMENSION BY MORE THAN 0.13mm.
DAMBAR INTRUSION SHALL NOT CAUSE THE LEAD TO BE NARROWER THAN THE MIN b DIMENSION BY MORE THAN 0.07mm.



EPW.com.cn