



Dual Power Supply Controller for Desktop Systems

ADP3156

FEATURES

- Active Voltage Positioning with Gain and Offset Adjustment
- Optimal Compensation for Superior Load Transient Response
- Fixed 1.5 V, 1.8 V and 2.5 V Output Versions
- Dual N-Channel Synchronous Driver
- On-Board Linear Regulator Controller
- Total Output Accuracy $\pm 1\%$ Over Temperature
- High Efficiency, Current-Mode Operation
- Short Circuit Protection
- Overtoltage Protection Crowbar Protects Loads with No Additional External Components
- Power Good Output
- SO-16 Package

APPLICATIONS

- Desktop Computer Supplies
- ACPI-Compliant Power Systems
- General Purpose DC-DC Converters

GENERAL DESCRIPTION

The ADP3156 is a highly efficient synchronous buck switching regulator controller optimized for converting the 3.3 V or 5 V main supply into lower supply voltages required on the motherboards of Pentium® III and other high performance processor systems. The ADP3156 uses a current mode, constant off-time architecture to drive two external N-channel MOSFETs at a programmable switching frequency that can be optimized for size and efficiency. It also uses a unique supplemental regulation technique called active voltage positioning to enhance load transient performance. Active voltage positioning results in a DC/DC converter that provides the best possible transient response using the minimum number of output capacitors and smallest footprint. Unlike voltage-mode and standard current-mode architectures, active voltage positioning adjusts the output voltage as a function of the load current so that it is always optimally positioned for a system transient.

The ADP3156 provides accurate and reliable short circuit protection and adjustable current limiting. It also includes an integrated overvoltage crowbar function to protect the microprocessor from destruction in case the core supply exceeds the nominal programmed voltage by more than 15%.

FUNCTIONAL BLOCK DIAGRAM

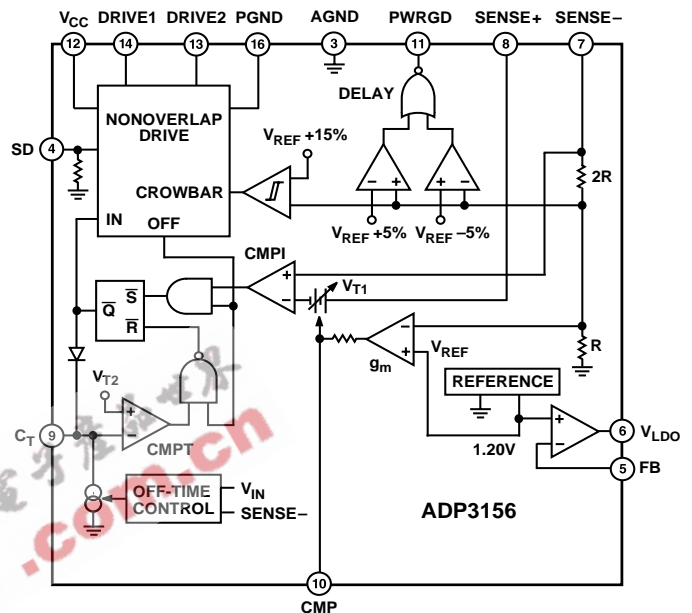

The ADP3156 contains a linear regulator controller that is designed to drive an external N-channel MOSFET. This linear regulator is used to generate the auxiliary voltages (AGP, GTL, etc.) required in most motherboard designs, and has been designed to provide a high bandwidth load-transient response. A pair of external feedback resistors sets the linear regulator output voltage.

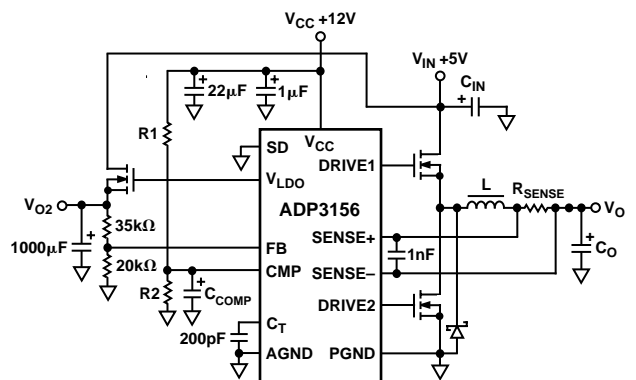

Figure 1. Typical Application

Pentium is a registered trademark of Intel Corporation. All other trademarks are the property of their respective holders.

REV. 0

Information furnished by Analog Devices is believed to be accurate and reliable. However, no responsibility is assumed by Analog Devices for its use, nor for any infringements of patents or other rights of third parties which may result from its use. No license is granted by implication or otherwise under any patent or patent rights of Analog Devices.

ADP3156—SPECIFICATIONS ($0^{\circ}\text{C} \leq T_A \leq +70^{\circ}\text{C}$, $V_{CC} = 12\text{ V}$, $V_{IN} = 5\text{ V}$, unless otherwise noted)¹

Parameter	Symbol	Conditions	Min	Typ	Max	Units
OUTPUT ACCURACY ADP3156-1.5 V ADP3156-1.8 V ADP3156-2.5 V	V_O		1.480 1.777 2.475	1.500 1.800 2.500	1.520 1.823 2.525	V V V
OUTPUT VOLTAGE LINE REGULATION	ΔV_O	$I_{LOAD} = 10\text{ A}$ (Figure 2) $V_{IN} = 4.75\text{ V}$ to 5.25 V		0.05		%
INPUT DC SUPPLY CURRENT ² Normal Mode Shutdown	I_Q	$V_{SD} = 0.6\text{ V}$ $T_A = +25^{\circ}\text{C}$, $V_{SD} = 2.0\text{ V}$		4.1 140	5.5 250	mA μA
CURRENT SENSE THRESHOLD VOLTAGE	$V_{SENSE(TH)}$	V_{SENSE-} Forced to $V_{OUT} - 3\%$	125	145	165	mV
C_T PIN DISCHARGE CURRENT	I_T	$T_A = +25^{\circ}\text{C}$ V_{OUT} in Regulation $V_{OUT} = 0\text{ V}$		65 2	10	μA μA
OFF-TIME	t_{OFF}	$C_T = 150\text{ pF}$	1.8	2.45	3.2	μs
DRIVER OUTPUT TRANSITION TIME	t_R , t_F	$C_L = 7000\text{ pF}$ (DRIVE1, 2) $T_A = +25^{\circ}\text{C}$		120	200	ns
POSITIVE POWER GOOD TRIP POINT ³	V_{PWRGD}	% Above Output Voltage		5	8	%
NEGATIVE POWER GOOD TRIP POINT ³	V_{PWRGD}	% Below Output Voltage	-8	-5		%
POWER GOOD RESPONSE TIME	t_{PWRGD}			500		μs
CROWBAR TRIP POINT	$V_{CROWBAR}$	% Above Output Voltage	9	15	24	%
ERROR AMPLIFIER OUTPUT IMPEDANCE	R_{OERR}			275		k Ω
ERROR AMPLIFIER TRANSCONDUCTANCE	$g_{m(ERR)}$			2.2		mmho
ERROR AMPLIFIER MINIMUM OUTPUT VOLTAGE	V_{CMPMIN}	V_{SENSE-} Forced to $V_{OUT} + 3\%$		0.8		V
ERROR AMPLIFIER MAXIMUM OUTPUT VOLTAGE	V_{CMPMAX}	V_{SENSE-} Forced to $V_{OUT} - 3\%$		2.4		V
ERROR AMPLIFIER BANDWIDTH -3 dB	BW_{ERR}	CMP = Open		500		kHz
LINEAR REGULATOR FEEDBACK CURRENT	I_{FB}			0.35	1	μA
LINEAR REGULATOR OUTPUT VOLTAGE	V_{O2}	Figure 2, $V_{LDOIN} = 1.8\text{ V}$ $R_{PROG} = 5\text{ k}\Omega$, $R_2 = 20\text{ k}\Omega$, $I_{O2} = 1\text{ A}$	1.47	1.5	1.53	V
SHUTDOWN (SD) PIN Low Threshold High Threshold Input Current	SD_L SD_H SD_{IC}	Part Active Part in Shutdown	2.0		0.6	V V μA

NOTES

¹All limits at temperature extremes are guaranteed via correlation using standard Statistical Quality Control (SQC) methods. Specifications subject to change without notice.

²Dynamic supply current is higher due to the gate charge being delivered to the external MOSFETs.

³The trip point is for the output voltage coming into regulation.

Specifications subject to change without notice.

PIN FUNCTION DESCRIPTIONS

Pin	Mnemonic	Function
1, 2, 15	NC	No Connect.
3	AGND	Analog Ground. All internal signals of the ADP3156 are referenced to this ground.
4	SD	Shutdown. A logic high will place the ADP3156 in shutdown and disable both outputs. This pin is internally pulled down.
5	FB	Feedback connection for the linear controller. Connect this pin to the resistor divider network to set the output voltage of the linear regulator.
6	V _{LDO}	Gate Drive for the linear regulator N-channel MOSFET.
7	SENSE-	Connects to the internal resistor divider that senses the output voltage. This pin is also the reference input for the current comparator.
8	SENSE+	(+) input for the current comparator. The output current is sensed as a voltage at this pin with respect to SENSE-.
9	C _T	External Capacitor C _T connection to ground sets the off-time of the device.
10	CMP	Error Amplifier output and compensation point. The voltage at this output programs the output current control level between the SENSE pins.
11	PWRGD	Power Good. An open drain signal indicates the output voltage is within a ±5% regulation band.
12	V _{CC}	Supply Voltage to ADP3156.
13	DRIVE2	Gate Drive for the (bottom) Synchronous Rectifier N-channel MOSFET. The voltage at DRIVE2 swings from ground to V _{CC} .
14	DRIVE1	Gate Drive for the buck switch N-channel MOSFET. The voltage at DRIVE1 swings from ground to V _{CC} .
16	PGND	Power Ground. The drivers turn off the buck and synchronous MOSFETs by discharging their gate capacitances to this pin. PGND should have a low impedance path to the source of the synchronous MOSFET.

ABSOLUTE MAXIMUM RATINGS*

Input Supply Voltage (V _{CC})	−0.3 V to +16 V
Shutdown Input Voltage	−0.3 V to +16 V
Operating Ambient Temperature Range	0°C to +70°C
Junction Temperature Range	0°C to +150°C
θ _{JA}	90°C/W
Storage Temperature Range	−65°C to +150°C
Lead Temperature (Soldering, 10 sec)	+300°C

*This is a stress rating only; operation beyond these limits can cause the device to be permanently damaged.

ORDERING GUIDE

Model	Buck Converter Output Voltage	Package Option
ADP3156JR-1.5	1.5 V	R-16A/SO-16
ADP3156JR-1.8	1.8 V	R-16A/SO-16
ADP3156JR-2.5	2.5 V	R-16A/SO-16

PIN CONFIGURATION

16-Lead SOIC

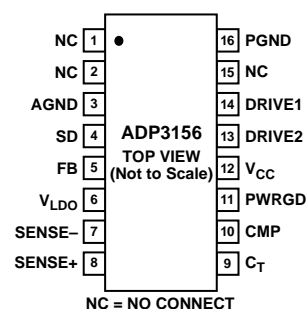

CAUTION

ESD (electrostatic discharge) sensitive device. Electrostatic charges as high as 4000 V readily accumulate on the human body and test equipment and can discharge without detection. Although the ADP3156 features proprietary ESD protection circuitry, permanent damage may occur on devices subjected to high energy electrostatic discharges. Therefore, proper ESD precautions are recommended to avoid performance degradation or loss of functionality.



ADP3156

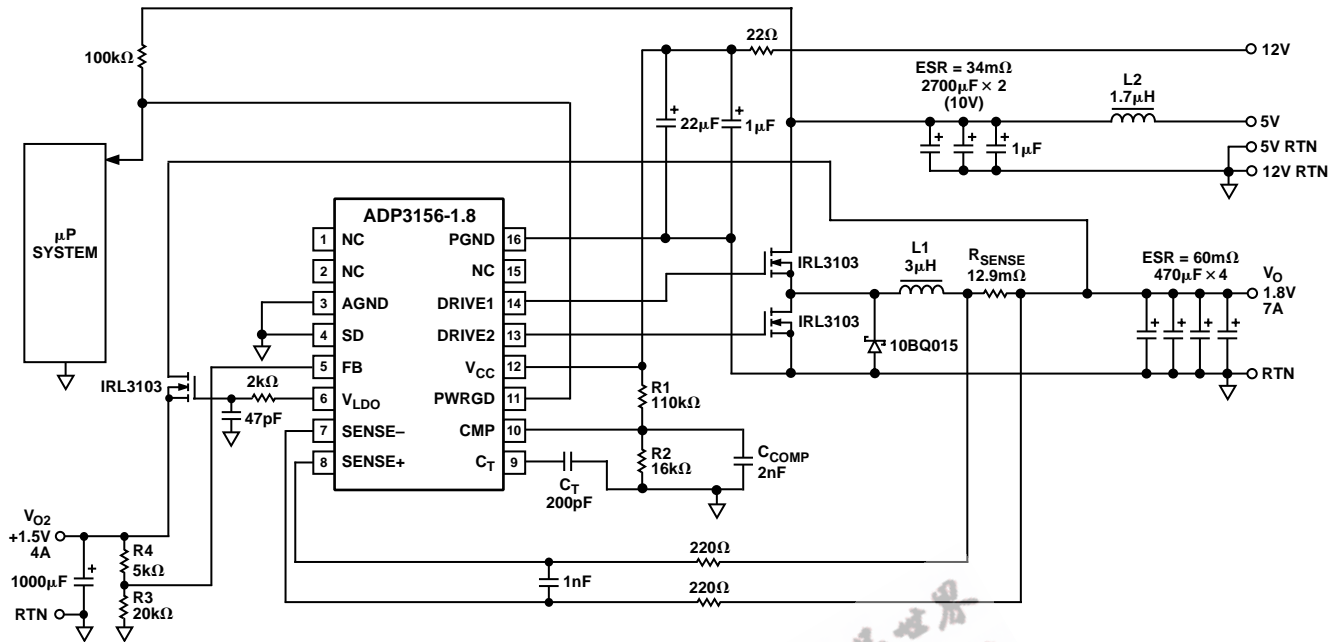

Figure 2. ADP3156 Typical VRM8.4 AGP and GTL Chipset DC/DC Converter Circuit

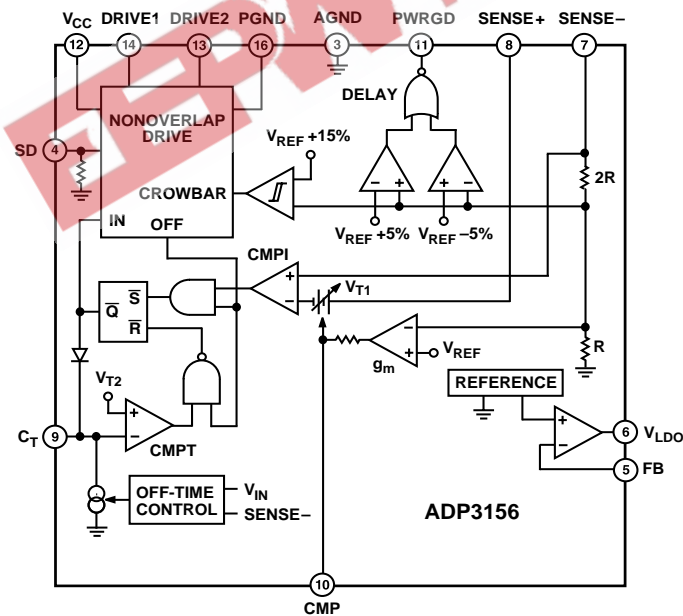

Figure 3. Functional Block Diagram

Typical Performance Characteristics—ADP3156

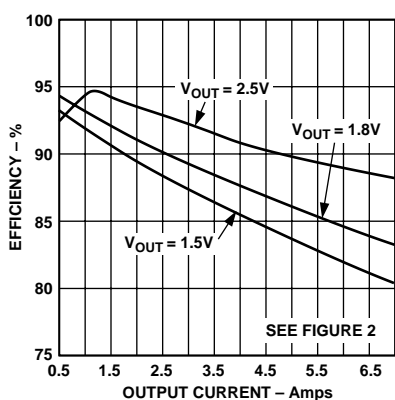

Figure 4. Efficiency vs. Output Current

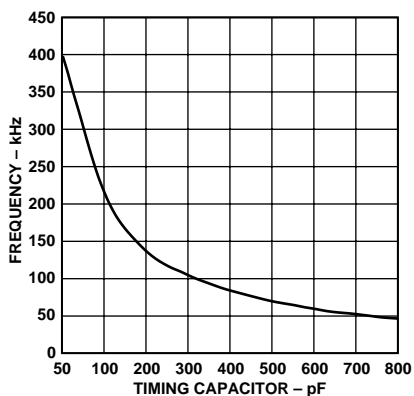

Figure 5. Frequency vs. Timing Capacitor

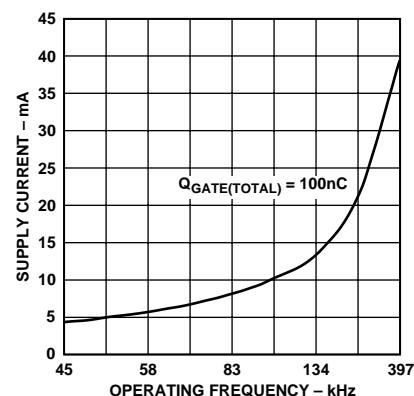

Figure 6. Supply Current vs. Operating Frequency

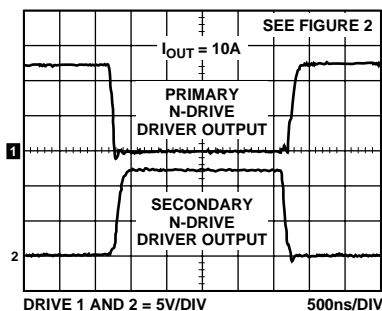

Figure 7. Gate Switching Waveforms

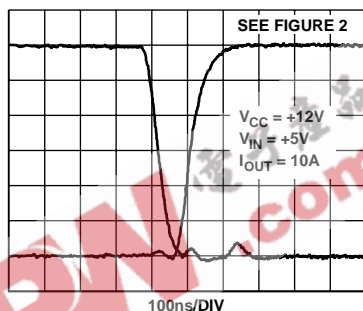

Figure 8. Driver Transition Waveforms

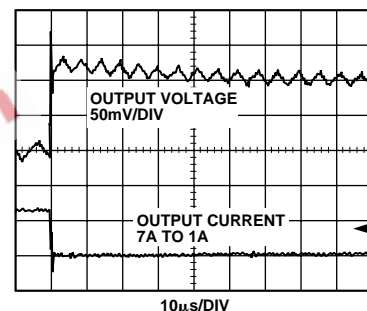

Figure 9. Transient Response, 7 A-1 A of Figure 2 Circuit

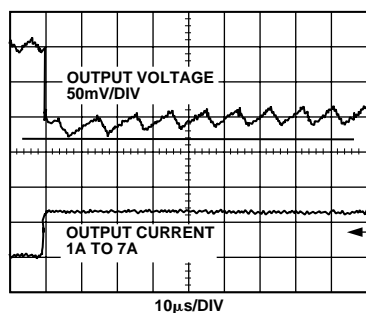

Figure 10. Transient Response, 1 A-7 A of Figure 2 Circuit

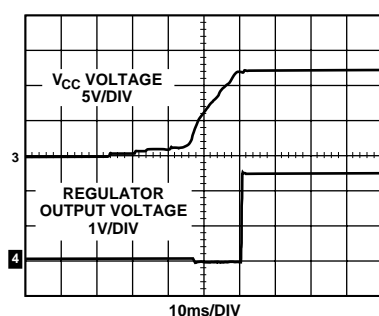

Figure 11. Power-On Start-Up Waveforms

ADP3156

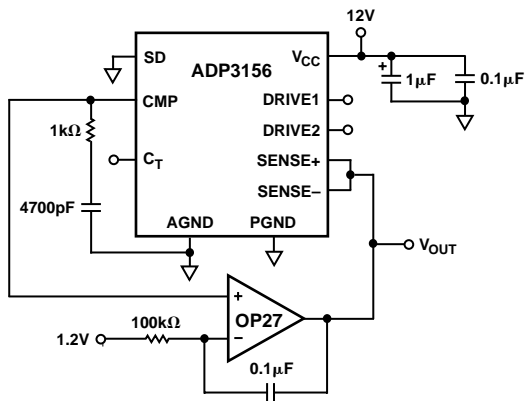

Figure 12. Closed-Loop Test Circuit for Accuracy

THEORY OF OPERATION

The ADP3156 uses a current-mode, constant-off-time control technique to switch a pair of external N-channel MOSFETs in a synchronous buck topology. Constant off-time operation offers several performance advantages, including that no slope compensation is required for stable operation. A unique feature of the constant-off-time control technique is that since the off-time is fixed, the converter's switching frequency is a function of the ratio of input voltage to output voltage. The fixed off-time is programmed by the value of an external capacitor connected to the C_T pin. The on-time varies in such a way that a regulated output voltage is maintained as described below in the cycle-by-cycle operation. Under fixed operating conditions the on-time does not vary, and it varies only slightly as a function of load. This means that switching frequency is fairly constant in standard VRM applications. In order to maintain a ripple current in the inductor, which is independent of the output voltage (which also helps control losses and simplify the inductor design), the off-time is made proportional to the value of the output voltage. Normally, the output voltage is constant and therefore the off-time is constant as well.

Active Voltage Positioning

The output voltage is sensed at the SENSE- pin. SENSE- is connected to an internal voltage divider. The output of the divider is then compared to the internal reference. A unique supplemental regulation technique called active voltage positioning with optimal compensation adjusts the output voltage as a function of the load current so that it is always optimally positioned for a load transient. Standard (passive) voltage positioning, sometimes recommended for use with other architectures, has poor dynamic performance which renders it ineffective under the stringent repetitive transient conditions specified in Intel VRM documents. Consequently, such techniques do not allow the minimum possible number of output capacitors to be used. Optimally compensated active voltage positioning, as used in the ADP3156, provides a bandwidth for transient response that is limited only by parasitic output inductance. This yields an optimal load transient response with the minimum number of output capacitors.

Cycle-by-Cycle Operation

During normal operation (when the output voltage is regulated), the voltage-error amplifier and the current comparator (CMPI) are the main control elements. (See the block diagram of Figure 3). During the on-time of the high side MOSFET, CMPI

monitors the voltage between the SENSE+ and SENSE- pins. When the voltage level between the two pins reaches the threshold level V_{T1} , the high side drive output is switched to ground, which turns off the high side MOSFET. The timing capacitor C_T is then discharged at a rate determined by the off-time controller. While the timing capacitor is discharging, the low side drive output goes high, turning on the low side MOSFET. When the voltage level on the timing capacitor has discharged to the threshold voltage level V_{T2} , comparator CMPT resets the SR flip-flop. The output of the flip-flop forces the low side drive output to go low and the high side drive output to go high. As a result, the low side switch is turned off and the high side switch is turned on. The sequence is then repeated. As the load current increases, the output voltage starts to decrease. This causes an increase in the output of the voltage-error amplifier, which, in turn, leads to an increase in the current comparator threshold V_{T1} , thus tracking the load current. To prevent cross conduction of the external MOSFETs, feedback is incorporated to sense the state of the driver output pins. Before the low side drive output can go high, the high side drive output must be low. Likewise, the high side drive output is unable to go high while the low side drive output is high.

Power Good

The ADP3156 has an internal monitor that senses the output voltage and drives the PWRGD pin of the device. This pin is an open drain output whose high level (when connected to a pull-up resistor) indicates that the output voltage has been within a $\pm 5\%$ regulation band of the targeted value for more than 500 μ s. The PWRGD pin will go low if the output is outside the regulation band for more than 500 μ s.

Output Crowbar

An added feature of using an N-channel MOSFET as the synchronous switch is the ability to crowbar the output with the same MOSFET. If the output voltage is 15% greater than the targeted value, the ADP3156 will turn on the lower MOSFET, which will current-limit the source power supply or blow its fuse, pull down the output voltage, and thus save the microprocessor from destruction. The crowbar function releases at approximately 50% of the nominal output voltage. For example, if the output is programmed to 2.0 V, but is pulled up to 2.3 V or above, the crowbar will turn on the lower MOSFET. If in this case the output is pulled down to less than 1.0 V, the crowbar will release, allowing the output voltage to recover to 2.0 V if the fault condition has been removed.

Shutdown

The ADP3156 has a shutdown (SD) pin that is pulled down by an internal resistor. In this condition the device functions normally. This pin should be pulled high to disable the output drives.

APPLICATION INFORMATION

A number of power conversion requirements must be considered when designing an ACPI compliant system. In normal operating mode, 12 V, 5 V and 3.3 V are available from the main supply. These voltages need to be converted into the appropriate supply voltages for the Northbridge core, the Southbridge core and RAMBUS memory, as well as supplies for GTL and I/O drivers, CMOS memory and clock and graphics (AGP) circuits.

During the standby operating state, the 12 V, 5 V and 3.3 V power supply outputs are disabled, and only a low power 5 V rail (5VSB) is available. The circuits that must remain active in standby must be able to run from 5VSB. To accomplish this, power routing is required to allow switching between normal and standby supplies. Lack of a 12 V rail in standby makes control of linear outputs difficult, and with up to 8 A demand from the 1.5 V and 1.8 V rails, an all-linear solution is inefficient.

Figure 13 shows a typical ACPI-compliant Pentium III / chipset power management system using the ADP3155 and ADP3156. The ADP3155 provides VID switched output and two linear regulators for standby operation. A charge-pump-doubled 5VSB is ORed into the supply rail to supply the linear regulators during standby operation. The VID output collapses when the main 5 V rail collapses, but the N-channel MOSFET linear regulators can continue to supply current from the ~9 V supply. The ADP3156 provides 1.8 V via its main switching regulator, and allows efficient linear regulation of 1.5 V rail by using the 1.8 V output as its source.

The design parameters for an ACPI-compliant Pentium III peripheral system depend on what peripherals are used (e.g., AGP) and what their specifications are. The following is an example where the higher of two low system voltages (1.8 V and 1.5 V) is created directly with the main buck converter, and also used to supply power for the lower output voltage using the ADP3156's linear regulator controller.

Input voltage (power source): $V_{IN} = 5 \text{ V}$

Auxiliary voltage: $V_{CC} = 12 \text{ V}$

Output voltages and tolerances: $V_1 = 1.8 \text{ V} \pm 5\%$, $V_2 = 1.5 \text{ V} \pm 5\%$

Maximum output currents: $I_{1MAX} = 3 \text{ A}$, $I_{2MAX} = 4 \text{ A}$

Slew rate of load current change: $di_1/dt = di_2/dt > 10 \text{ A}/\mu\text{s}$

The absence of an inductor on the 1.5 V linear regulated output allows the output current to respond quickly and the linear regulator MOSFET's resistance to be modulated quickly. This, and some small bypassing capacitors, essentially insulates the 1.5 V output from transient activity on the 1.8 V output. However, this same fast response characteristic means that any 1.5 V transient activity will be passed straight through the linear regulator to the 1.8 V output. This means that the 1.8 V output filter capacitor selection must consider both 1.8 V and 1.5 V load transients.

In this design example, worst case consideration requires that the 1.8 V output be designed for transient current loading of $I_{1MAX} + I_{2MAX} = 7 \text{ A}$. Also, because a practical switching regulator design will have a current slew rate of $< 1 \text{ A}/\mu\text{s}$ due to the inductor, nearly the entire 7 A transient current must be absorbed by the output capacitors.

C_T Selection for Operating Frequency

The ADP3156 uses a constant-off-time architecture with t_{OFF} determined by an external timing capacitor C_T . Each time the high side N-channel MOSFET switch turns on, the voltage across C_T is reset to approximately 3.3 V. During the off-time, C_T is discharged by a constant current of 65 μA . Once C_T reaches 2.3 V, a new on-time cycle is initiated. The value of the off-time is calculated using the continuous-mode operating frequency. Assuming a nominal operating frequency of $f_{NOM} = 200 \text{ kHz}$ at an output voltage of 1.8 V, the corresponding off-time is:

$$t_{OFF} = \left(1 - \frac{V_O}{V_{IN}}\right) \frac{1}{f_{NOM}} = 3.2 \mu\text{s}$$

The timing capacitor can be calculated from the equation:

$$C_T = \frac{t_{OFF} \times 65 \mu\text{A}}{1 \text{ V}} = 208 \text{ pF}$$

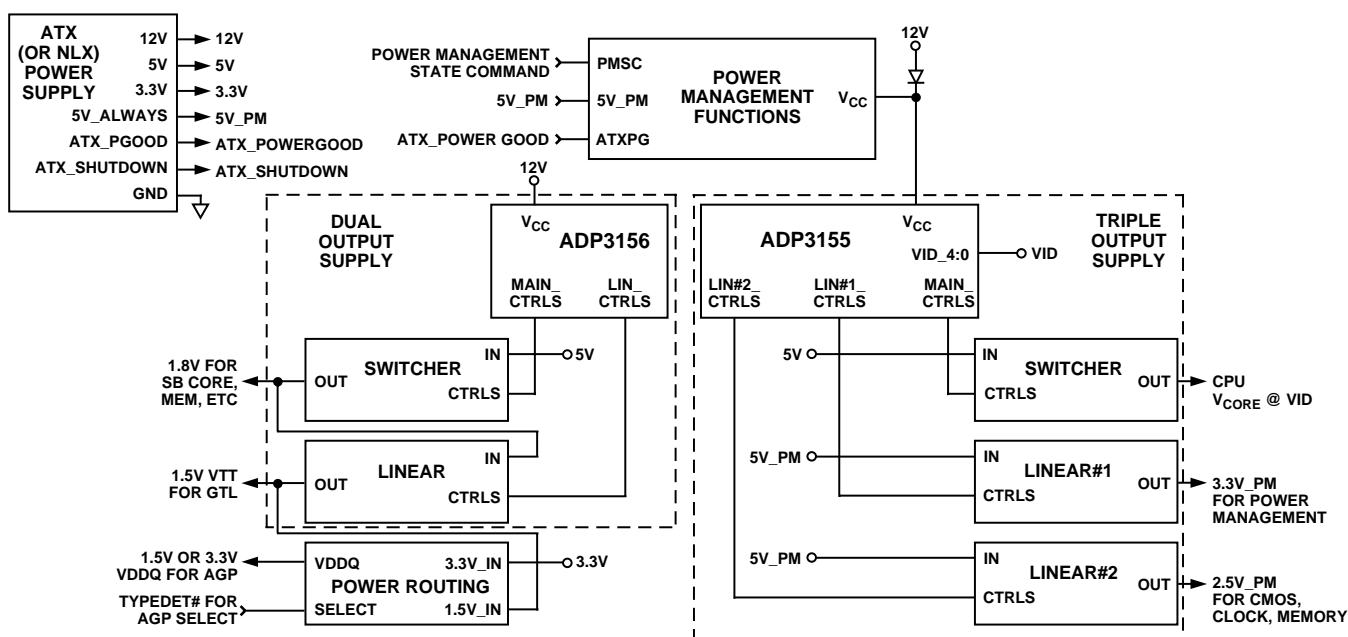

Figure 13. ACPI-Compliant Pentium III System Block Diagram

ADP3156

The converter operates at the nominal operating frequency only at the V_{OUT} specified above, and at light load. At higher load conditions, the operating frequency decreases due to the parasitic voltage drops across the power devices. The actual minimum frequency at $V_{OUT} = 1.8\text{ V}$ is calculated from Equation 1, and is a function of the finite resistances of various components in the power converter.

C_{OUT} Selection—Determining the ESR

The required ESR and capacitance drive the selection of the type and quantity of the output capacitors. The ESR must be small enough that both the resistive voltage deviation due to a step change in the load current and the output ripple voltage stay below the values defined in the specification of the supplied circuitry. The capacitance must be large enough that the output is held up while the inductor current ramps up or down to the value corresponding to the new load current.

Taking into account the $\pm 1\%$ setpoint accuracy of the ADP3156, and assuming a 1% (or 15 mV) peak-to-peak ripple, the allowed static voltage deviation of the output voltage when the load changes between the minimum and maximum values is:

$$(2 \times 5\% \times 1.5\text{ V}) - (2 \times 1\% \times 1.5\text{ V}) - (1\% \times 1.5\text{ V}) = 105\text{ mV}$$

This sets the maximum ESR at $105\text{ mV}/7\text{ A} = 15\text{ m}\Omega$. Four parallel capacitors of $470\text{ }\mu\text{F}$ with a maximum ESR of $60\text{ m}\Omega$ will achieve the $15\text{ m}\Omega$ maximum net ESR. Whether or not the capacitance is sufficient must be determined after the inductor is selected.

Inductor Selection

The minimum inductor value can be calculated from ESR, off-time, dc output voltage and allowed peak-to-peak ripple voltage using the following equation:

$$L_{MIN1} = \frac{V_{OFF} R_{E(MAX)}}{V_{RIPPLE\ p-p}} = \frac{1.5 \times 3.2\text{ }\mu\text{s} \times 7\text{ m}\Omega}{15\text{ mV}} = 2.24\text{ }\mu\text{H}$$

The minimum inductance gives a peak-to-peak ripple current of 2.14 A, or 35% of the maximum dc output current I_{OMAX} . The inductor peak current in normal operation is:

$$I_{LPEAK} = I_{OMAX} + I_{RPP}/2 = 8.07\text{ A}$$

The inductor valley current is:

$$I_{LVALLEY} = I_{LPEAK} - I_{RPP}/2 = 5.93\text{ A}$$

The inductor for this application should have an inductance of not less than $2.24\text{ }\mu\text{H}$ at full load current and should not saturate at the worst-case overload or short circuit current at the maximum specified ambient temperature. For this example, it is assumed the inductance might drop as much as 33% due to load current, so its initial value might be as high as $3.36\text{ }\mu\text{H}$.

Tips for Selecting the Inductor Core

Ferrite designs have very low core loss, so the design should focus on copper loss and on preventing saturation. Molypermalloy, or MPP, is a low loss core material for toroids, and it yields the smallest size inductor, but MPP cores are more expensive than ferrite cores or the Kool M μ ® cores from Magnetics, Inc. The

lowest cost core is made of powdered iron, for example the #52 material from Micrometals, Inc., but yields a larger size inductor.

C_{OUT} Selection—Determining the Capacitance

The minimum capacitance of the output capacitor is determined from the requirement that the output be held up while the inductor current ramps up (or down) to the new value. The minimum capacitance should produce an initial dv/dt which is equal (but opposite in sign) to the dv/dt obtained by multiplying the di/dt in the inductor and the ESR of the capacitor.

$$C_{MIN} = \frac{I_{OMAX} - I_{OMIN}}{R_E(di/dt)}$$

$$C_{MIN} = \frac{7\text{ A} - 0\text{ A}}{15\text{ m}\Omega(1.8\text{ V}/3.36\text{ }\mu\text{H})} = 871\text{ }\mu\text{F}$$

In the above equation the value of di/dt is calculated as the smaller voltage across the inductor (i.e., the smaller of $V_{IN} - V_{OUT}$ and V_{OUT}) divided by the maximum inductance ($3.36\text{ }\mu\text{H}$) of the inductor. The four parallel-connected $470\text{ }\mu\text{F}$ capacitors have a total capacitance of $1880\text{ }\mu\text{F}$, so the minimum capacitance requirement is met with ample margin.

R_{SENSE}

The value of R_{SENSE} is based on the required output current. The current comparator of the ADP3156 has a threshold range that extends from 0 mV to 125 mV (minimum). Note that the full 125 mV range cannot be used for the maximum specified nominal current, as headroom is needed for current ripple and transients.

The current comparator threshold sets the peak of the inductor current yielding a maximum output current I_{OMAX} , which equals the peak value less half of the peak-to-peak ripple current. Solving for R_{SENSE} and allowing a 20% margin for overhead, and using the minimum current sense threshold of 125 mV yields:

$$R_{SENSE} = (125\text{ mV})/[1.2(I_{OMAX} + I_{RPP}/2)] = 12.9\text{ m}\Omega$$

Once R_{SENSE} has been chosen, the peak short-circuit current $I_{SC(PK)}$ can be predicted from the following equation:

$$I_{SC(PK)} = (145\text{ mV})/R_{SENSE} = (145\text{ mV})/(12.9\text{ m}\Omega) = 11.2\text{ A}$$

The actual short-circuit current is less than the above-calculated $I_{SC(PK)}$ value because the off-time rapidly increases when the output voltage drops below 1 V. The relationship between the off-time and the output voltage is:

$$t_{OFF} \approx \frac{C_T \times 1\text{ V}}{\frac{V_O}{360\text{ k}\Omega} + 2\text{ }\mu\text{A}}$$

With a short circuit across the output, the off-time will be about $104\text{ }\mu\text{s}$. During that time the inductor current gradually decays. The amount of decay depends on the L/R time constant in the output circuit. With an inductance of $2.24\text{ }\mu\text{H}$ and total resistance of $40\text{ m}\Omega$ (the inductor's series resistance plus the sense resistor), the time constant will be $56\text{ }\mu\text{s}$. This yields a valley

$$f_{MIN} = \frac{1}{t_{OFF}} \times \frac{V_{IN} - I_{IN}R_{IN} - I_{OMAX}(R_{DS(ON)HSF} + R_{SENSE} + R_L) - V_O}{V_{IN} - I_{IN}R_{IN} - I_{OMAX}(R_{DS(ON)HSF} + R_{SENSE} + R_L - R_{DS(ON)LSF}} \quad (1)$$

current of 1.7 A and an average short-circuit current of about 6.5 A—meaning that there is actually a small degree of short-circuit current foldback. To safely carry the maximum current, the sense resistor must have a power rating of at least $(11.2 \text{ A} - 1.07 \text{ A})^2 \times 12.9 \text{ m}\Omega = 1.3 \text{ W}$.

Current Transformer Option

An alternative to using a low value and high power current sense resistor is to reduce the sensed current by using a low cost current transformer and a diode. The current can then be sensed with a small size, low cost SMT resistor. Using a transformer with one primary and 50 secondary turns reduces the worst-case resistor dissipation to a few mW. Another advantage of using this option is the separation of the current and voltage sensing, which makes the voltage sensing more accurate.

Power MOSFETs

Two external N-channel power MOSFETs must be selected for use with the ADP3156, one for the main switch, and an identical one for the synchronous switch. The main selection parameters for the power MOSFETs are the threshold voltage $V_{GS(TH)}$ and the on resistance $R_{DS(ON)}$. The minimum input voltage dictates whether standard threshold or logic-level threshold MOSFETs must be used. For $V_{IN} > 8 \text{ V}$, standard threshold MOSFETs ($V_{GS(TH)} < 4 \text{ V}$) may be used. If V_{IN} is expected to drop below 8 V, logic-level threshold MOSFETs ($V_{GS(TH)} < 2.5 \text{ V}$) are strongly recommended. Only logic-level MOSFETs with V_{GS} ratings higher than the absolute maximum of V_{CC} should be used.

The maximum output current I_{OMAX} determines the $R_{DS(ON)}$ requirement for the two power MOSFETs. When the ADP3156 is operating in continuous mode, the simplifying assumption can be made that one of the two MOSFETs is always conducting the average load current. For $V_{IN} = 5 \text{ V}$ and $V_{OUT} = 1.8 \text{ V}$, the maximum duty ratio of the high side FET is:

$$D_{MAXHF} = (1 - f_{MIN} \times t_{OFF}) = (1 - 150 \text{ kHz} \times 3.2 \mu\text{s}) = 52\%$$

The duty ratio of the low side (synchronous rectifier) FET under the maximum load condition is:

$$D_{MAXLF} = 1 - D_{MAXHF} = 48\%$$

The maximum rms current of the high side FET is:

$$I_{RMSHS} = [D_{MAXHF} (I_{LVALLEY}^2 + I_{LPEAK}^2 + I_{LVALLEY}I_{LPEAK})/3]^{0.5} = 7.32 \text{ A rms}$$

The maximum rms current of the low side FET is:

$$I_{RMSLS} = [D_{MAXLF} (I_{LVALLEY}^2 + I_{LPEAK}^2 + I_{LVALLEY}I_{LPEAK})/3]^{0.5} = 7.03 \text{ A rms}$$

The $R_{DS(ON)}$ for each FET can be derived from the allowable dissipation. Allowing 8% of the maximum output power for FET dissipation, the total dissipation will be:

$$P_{FETALL} = 0.08 V_O I_{OMAX} = 1.0 \text{ W}$$

Allocating half of the total dissipation for the high side FET and half for the low side FET, the required minimum FET resistances will be:

$$R_{DS(ON)HSF(MIN)} = 1 \text{ W} \times 52\% / (7.32 \text{ A})^2 = 9.7 \text{ m}\Omega$$

$$R_{DS(ON)LSF(MIN)} = 1 \text{ W} \times 48\% / (7.03 \text{ A})^2 = 9.7 \text{ m}\Omega$$

Note that there is a trade-off between converter efficiency and cost. Larger FETs reduce the conduction losses and allow higher efficiency, but increase the system cost. If efficiency is not a major concern, the International Rectifier IRL3103 is an

economical choice for both the high side and low side positions. Those devices have an $R_{DS(ON)}$ of 14 m Ω at $V_{GS} = 10 \text{ V}$ and at +25°C. The low side FET is turned on with at least 10 V. The high side FET, however, is turned on with only 12 V – 5 V = 7 V. Checking the typical output characteristics of the device in the data sheet, shows that for an output current of 10 A, and at a V_{GS} of 7 V, the V_{DS} is 0.15 V. This gives an $R_{DS(ON)}$ only slightly above the one specified at a V_{GS} of 10 V, so the resistance increase due to the reduced gate drive can be neglected. The specified $R_{DS(ON)}$ at the expected highest FET junction temperature of +140°C must be modified by an $R_{DS(ON)}$ multiplier, using the graph in the data sheet. In this case:

$$R_{DS(ON)MULT} = 1.7$$

Using this multiplier, the expected $R_{DS(ON)}$ at +140°C is $1.7 \times 14 = 24 \text{ m}\Omega$.

The high side FET dissipation is:

$$P_{DFETHS} = I_{RMSHS}^2 R_{DS(ON)} + 0.5 V_{IN} I_{LPEAK} Q_G f_{MIN} / I_G \sim 2.54 \text{ W}$$

where the second term represents the turn-off loss of the FET. (In the second term, Q_G is the gate charge to be removed from the gate for turn-off and I_G is the gate current. From the data sheet, Q_G is about 50 nC–70 nC and the gate drive current provided by the ADP3156 is about 1 A.)

The low side FET dissipation is:

$$P_{DFETLS} = I_{RMSLS}^2 R_{DS(ON)} = 0.49 \text{ W}$$

(Note that there are no switching losses in the low side FET.)

To maintain an acceptable MOSFET junction temperature, proper heat sinking should be used. The heat sink and airflow are chosen based on how low the impedance must be reduced in order to keep the MOSFET's junction temperature at an acceptably low level, according to the formula:

$$\theta_{HA} = [(T_{JMAXOP} - T_A) / P_{DFET}] - \theta_{JC} - \theta_{CH}$$

where θ_{HA} is the thermal resistance from the heat sink to ambient air (and depends on airflow), T_{JMAXOP} is the user-determined maximum acceptable operating temperature of the MOSFET, and the last two factors are the thermal resistance from junction-to-case of the device, and case-to-heat sink. Typically, the junction-to-case thermal resistance is 2°C/W, and the case-to-heat sink resistance is 0.5°C/W.

C_{IN} Selection and Input Current di/dt Reduction

In continuous-inductor-current mode, the source current of the high side MOSFET is a square wave with a duty ratio of V_O/V_{IN} . To keep the input ripple voltage at a low value, one or more capacitors with low equivalent series resistance (ESR) and adequate ripple-current rating must be connected across the input terminals. The maximum rms current of the input bypass capacitors is:

$$I_{CINRMS} = I_{OMAX} [D_{MAX} \times (1 - D_{MAX})]^{0.5} = 3.5 \text{ A}$$

For an FA-type capacitor with 2700 mF capacitance and 10 V voltage rating, the ESR is 34 m Ω and the allowed ripple current at 100 kHz (and similar frequencies) is 1.94 A. At +105°C, two such capacitors may be connected in parallel to handle the calculated ripple current.

To further reduce the effect of the ripple voltage on the system supply voltage bus and to reduce the input-current di/dt to below the recommended maximum of 0.1 A/ μs , an additional small inductor should be inserted between the converter and the supply bus (see Figure 2).

ADP3156

Feedback Loop Compensation Design for Active Voltage Positioning

Optimized compensation of the ADP3156 allows the best possible containment of the peak-to-peak output voltage deviation. Any practical switching power converter is inherently limited by the inductor in its output current slew rate to a value much less than the slew rate of the load. Therefore, any sudden change of load current will initially flow through the output capacitors, and this will produce an output voltage deviation equal to the ESR of the output capacitor array times the load current change. To correctly implement active voltage positioning, the low frequency output impedance (i.e., the output resistance) of the converter should be made equal to the maximum ESR of the output capacitor array. This can be achieved by having a single pole roll-off of the voltage gain of the g_m error amplifier, where the pole frequency coincides with the ESR zero of the output capacitor. A gain with single pole roll-off requires that the g_m amplifier output pin be terminated by the parallel combination of a resistor and capacitor. The required resistor value can be calculated from the equation:

$$R_C = \frac{275 \text{ k}\Omega \times R_{tTOTAL}}{275 \text{ k}\Omega - R_{tTOTAL}}$$

where:

$$R_{tTOTAL} = \frac{16.4 \text{ k}\Omega \times R_{CS} \times I_{OMAX}}{V_{HI} - V_{LO}}$$

where the quantities 16.4 k Ω and 275 k Ω are characteristics of the ADP3156, the value of the current sense resistor, R_{CS} , has already been determined as above, and where V_{HI} and V_{LO} are the respective upper and lower limits allowed for regulation. Although a single termination resistor equal to R_C would yield the proper voltage positioning gain, the dc biasing of that resistor would determine how the regulation band is centered (i.e., note that sometimes the specified regulation band is asymmetrical with respect to the nominal VID voltage.) With the ADP3156, the offset is already considered as part of the design procedure—no special provision is required. To accomplish the dc biasing, it is simplest to use two resistors to terminate the g_m output, with the lower resistor tied to ground and the upper resistor to the 12 V supply of the IC. The values of these resistors can be calculated using:

$$R_{UPPER} = R_C \times \frac{V_{DIV}}{V_{OS}}$$

and:

$$R_{LOWER} = R_C \times \frac{V_{OS}}{V_{DIV} - V_{OS}}$$

where V_{DIV} is the resistor divider supply voltage (e.g., the recommended 12 V), and V_{OS} is the offset voltage required on the amplifier to produce the desired offset at the output. V_{OS} is

$$V_{OS} = \frac{R_C}{R_{tTOTAL}} \times \left[0.8 \text{ V} + V_{OUT(OS)} \left(\frac{R_{tTOTAL}}{1.36 \text{ k}\Omega} \right) - 1.7 \text{ V} \left(\frac{R_{tTOTAL}}{275 \text{ k}\Omega} \right) + 6 R_{CS} I_{OMAX} \right] \quad (2)$$

calculated using Equation 2, where $V_{OUT(OS)}$ is the offset from the nominal VID-programmed value to the center of the specified regulation window for the output voltage. (Note this may be either positive or negative.) For clarification, that offset is given by:

$$V_{OUT(OS)} = \frac{1}{2} (V_{HI} + V_{LO}) - VID$$

Finally, the compensating capacitance is determined from the equality of the pole frequency of the error amplifier gain and the zero frequency of the impedance of the output capacitor:

$$C_{COMP} = \frac{C_O \times ESR}{R_{tTOTAL}}$$

Trade-Offs Between DC Load Regulation and AC Load Regulation

Casual observation of the circuit operation—e.g., with a voltmeter—would make it appear that the dc load regulation appears to be rather poor compared to a conventional regulator. This would be especially noticeable under very light or very heavy loads where the voltage is “positioned” near one of the extremes of the regulation window rather than near the nominal center value. It must be noted and understood that this low gain characteristic (i.e., loose dc load regulation) is inherently required to allow improved transient containment (i.e., to achieve tighter ac load regulation). That is, the dc load regulation is intentionally sacrificed (but kept within specification) in order to minimize the number of capacitors required to contain the load transients produced by the CPU.

Linear Regulator

The ADP3156 linear regulator provides a low cost, convenient and versatile solution for generating a lower supply rail in addition to the main output. The maximum output load current is determined by the size and thermal impedance of the external N-channel power MOSFET that is controlled by the ADP3156. The output voltage, V_{O2} in Figure 14, is sensed at the FB pin of the ADP3156 and compared to an internal 1.2 V reference in a negative feedback loop which keeps the output voltage in regulation. If the load is being reduced or increased, the FET drive will also be reduced or increased by the ADP3156 to provide a well regulated $\pm 1\%$ accurate output voltage. The output voltage is programmed by adjusting the value of the external resistor R_{PROG} , shown in Figure 14.

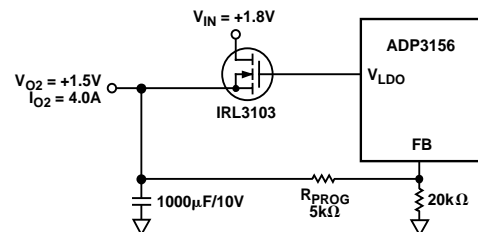

Figure 14. Linear Regulator Configuration

Efficiency of the Linear Regulator

The efficiency and corresponding power dissipation of the linear regulator are not determined by the ADP3156. Rather, these are a function of input and output voltage and load current. Efficiency is approximated by the formula:

$$\eta = 100\% \times (V_{OUT} \div V_{IN})$$

The corresponding power dissipation in the MOSFET, together with any resistance added in series from input to output is given by:

$$P_{LDO} = (V_{IN(LDO)} - V_{OUT(LDO)}) \times I_{OUT(LDO)}$$

Minimum power dissipation and maximum efficiency are accomplished by choosing the lowest available input voltage that exceeds the desired output voltage. However, if the chosen input source is itself generated by a linear regulator, its power dissipation will be increased in proportion to the additional current it must now provide. For most PC systems, the lowest available input source for the linear regulators, which is not itself generated by a linear regulator, is 3.3 V from the main power supply. However, in this case, the main output of the ADP3156 creates a lower voltage that may be used as the source supply for the linear regulator. Assuming that a 1.8 V main output is used to provide power for a 1.5 V linear regulator output, the efficiency will nominally be $1.5 \text{ V} \div 1.8 \text{ V} = 83\%$.

If the 1.5 V output must supply a 4 A maximum load (a total of 6 W), the steady state dissipation in the MOSFET may be as high as:

$$P_{LDO(MAX)} = (V_{IN} - V_{OUT}) \times I_{OUT(MAX)} = (1.8 \text{ V} - 1.5 \text{ V}) \times 4 \text{ A} = 1.2 \text{ W}$$

The minimum acceptable on-resistance of the MOSFET that would deliver the 4 A load with only a 0.3 V difference between input and output is:

$$R_{DS(ON, MAX)} = (V_{OUT} - V_{IN}) \div I_{OUT(MAX)} = (1.8 \text{ V} - 1.5 \text{ V}) \div 4 \text{ A} = 75 \text{ m}\Omega$$

There are many MOSFETs to choose from that can support the maximum power dissipation without need for a heat sink and without exceeding the calculated maximum on-resistance. For simplicity it may be desirable to use the same MOSFET as is used for the main power converter.

The output voltage may be programmed by the R_{PROG} resistor as follows:

$$R_{PROG} = \left(\frac{V_{O2}}{1.2 \text{ V}} - 1 \right) \times 20 \text{ k}\Omega = \left(\frac{1.5}{1.2} - 1 \right) \times 20 \text{ k}\Omega = 5 \text{ k}\Omega$$

The output filter capacitor maximum allowed ESR is:

$$ESR \sim V_{TR2} / I_{OMAX} = 0.036 / 0.5 = 0.072 \text{ }\Omega$$

where V_{TR2} is the maximum allowed transient deviation on the output. This requirement is met using a 1000 $\mu\text{F}/10 \text{ V}$ LXV series capacitor from United Chemicon. For applications requiring higher output current, a heat sink and/or a larger MOSFET should be used to reduce the MOSFET's junction-to-ambient thermal impedance.

LAYOUT AND COMPONENT PLACEMENT GUIDELINES

The following guidelines are recommended for optimal performance of a switching regulator in a PC system:

General Recommendations

1. For best results, a four-layer (minimum) PCB is recommended. This should allow the needed versatility for control circuitry interconnections with optimal placement, a signal ground plane, power planes for both power ground and the input power (e.g., 5 V), and wide interconnection traces in the rest of the power delivery current paths. Each square unit of 1 ounce copper trace has a resistance of $\sim 0.53 \text{ m}\Omega$ at room temperature.
2. Whenever high currents must be routed between PCB layers vias should be used liberally to create several parallel current paths so that the resistance and inductance introduced by these current paths is minimized and the via current rating is not exceeded.
3. The power and ground planes should overlap each other as little as possible. It is generally the easiest (although not necessary) to have the power and signal ground planes on the same PCB layer. The planes should be connected nearest to the first input capacitor where the input ground current flows from the converter back to the power source (e.g., 5 V).
4. If critical signal lines (including the voltage and current sense lines of the ADP3156) must cross through power circuitry, it is best if a signal ground plane can be interposed between those signal lines and the traces of the power circuitry. This serves as a shield to minimize noise injection into the signals at the expense of making signal ground a bit noisier.
5. The PGND pin of the ADP3156 should connect first to a ceramic bypass capacitor (on the V_{CC} pin) and then into the power ground plane using the shortest possible trace. However, the power ground plane should not extend under other signal components, including the ADP3156 itself. If necessary, follow the preceding guideline to use the signal plane as a shield between the power ground plane and the signal circuitry.
6. The AGND pin of the ADP3156 should connect first to the timing capacitor (on the C_T pin), and then into the signal ground plane. In cases where no signal ground plane can be used, short interconnections to other signal ground circuitry in the power converter should be used—the compensation capacitor being the next most critical.
7. The output capacitors of the power converter should be connected to the signal ground plane even though power current flows in the ground of these capacitors. For this reason, it is advised to avoid critical ground connections (e.g., the signal circuitry of the power converter) in the signal ground plane in between the input and output capacitors. It is also advised to keep the planar interconnection path short (i.e., have input and output capacitors close together).
8. The output capacitors should also be connected as closely as possible to the load (or connector) which receives the power (e.g., a microprocessor core). If the load is distributed, the capacitors also should be distributed, and generally in proportion to where the load tends to be more dynamic.

ADP3156

- Absolutely avoid crossing any signal lines over the switching power path loop, described below.

Power Circuitry

- The switching power path should be routed on the PCB to encompass the smallest possible area in order to minimize radiated switching noise energy (i.e., EMI). Failure to take proper precaution often results in EMI problems for the entire PC system as well as noise-related operational problems in the power converter control circuitry. The switching power path is the loop formed by the current path through the input capacitors, the two FETs, and the power Schottky diode if used, including all interconnecting PCB traces and planes. The use of short and wide interconnection traces is especially critical in this path for two reasons: it minimizes the inductance in the switching loop, which can cause high-energy ringing, and it accommodates the high current demand with minimal voltage loss.
- A power Schottky diode (1~2 A dc rating) placed from the lower FET's source (anode) to drain (cathode) will help to minimize switching power dissipation in the upper FET. In the absence of an effective Schottky diode, this dissipation occurs through the following sequence of switching events. The lower FET turns off in advance of the upper FET turning on (necessary to prevent cross-conduction). The circulating current in the power converter, no longer finding a path for current through the channel of the lower FET, draws current through the inherent body-drain diode of the FET. The upper FET turns on, and the reverse recovery characteristic of the lower FET's body-drain diode prevents the drain voltage from being pulled high quickly. The upper FET then conducts very large current while it momentarily has a high voltage forced across it, which translates into added power dissipation in the upper FET. The Schottky diode minimizes this problem by carrying a majority of the circulating current when the lower FET is turned off, and by virtue of its essentially nonexistent reverse recovery time.
- A small ferrite bead inductor placed in series with the drain of the lower FET can also help to reduce this previously described source of switching power loss.
- Whenever a power dissipating component (e.g., a power MOSFET) is soldered to a PCB, the liberal use of vias both directly on the mounting pad and immediately surrounding it is recommended. Two important reasons for this are: improved current rating through the vias (if it is a current path), and improved thermal performance—especially if the vias extended to the opposite side of the PCB where a plane can more readily transfer the heat to the air.
- The output power path, though not as critical as the switching power path, should also be routed to encompass a small area. The output power path is formed by the current path through the inductor, the current sensing resistor, the output capacitors, and back to the input capacitors.

- For best EMI containment, the power ground plane should extend fully under all the power components except the output capacitors. These are: the input capacitors, the power MOSFETs and Schottky diode, the inductor, the current sense resistor, and any snubbing elements that might be added to dampen ringing. Avoid extending the power ground under any other circuitry or signal lines, including the voltage and current sense lines.

Signal Circuitry

- The output voltage is sensed and regulated between the AGND pin (which connects to the signal ground plane) and the SENSE- pin. The output current is sensed (as a voltage) and regulated between the SENSE- pin and the SENSE+ pin. In order to avoid differential mode noise pickup in those sensed signals, their loop areas should be small. Thus the SENSE- trace should be routed atop the signal ground plane, and the SENSE+ and SENSE- traces should be routed as a closely coupled pair (SENSE+ should be over the signal ground plane as well).
- The SENSE+ and SENSE- traces should be Kelvin connected to the current sense resistor so that the additional voltage drop due to current flow on the PCB at the current sense resistor connections does not affect the sensed voltage. It is desirable to both have the ADP3156 close to the output capacitor bank and not in the output power path so that any voltage drop between the output capacitors and the AGND pin is minimized, and voltage regulation is not compromised.

OUTLINE DIMENSIONS

Dimensions shown in inches and (mm).

16-Lead Standard Small Outline Package (SOIC) (R-16A)

