

FEATURES

- Wide input voltage range: 5.5 V to 25 V**
- High conversion efficiency > 96%**
- Integrated current sense—no external resistor required**
- Low shutdown current: 19 μ A (typical)**
- Voltage mode PWM with input feed-forward for fast line transient response**
- Dual synchronous buck controllers**
- Built-in gate drive boost circuit for driving external high-side N-channel MOSFET**
- 2 independently programmable output voltages:**
 - Fixed 3.3 V or adjustable (800 mV to 6.0 V)**
 - Fixed 5 V or adjustable (800 mV to 6.0 V)**
- Programmable PWM frequency**
- Integrated linear regulator controller**
- Extensive circuit protection functions**

APPLICATIONS

- Portable instruments**
- General-purpose dc-to-dc converters**

GENERAL DESCRIPTION

The ADP3025 is a highly efficient, dual synchronous buck switching regulator controller optimized for converting a battery or adapter input into the supply voltage required in portable products and industrial systems. The oscillator frequency can be programmed for 200 kHz or 300 kHz operation, or can be synchronized to an external clock signal of up to 350 kHz.

The ADP3025 provides accurate and reliable short-circuit protection by using an internal current sense circuit that reduces cost and increases overall efficiency. Other protection features include programmable soft start, UVLO, and integrated output undervoltage/overvoltage protection. The ADP3025 contains a linear regulator controller designed to drive an external N-channel MOSFET. The linear regulator output is adjustable and can be used to generate auxiliary supply voltages.

The ADP3025 is specified over the 0°C to 70°C commercial temperature range and is available in a 38-lead TSSOP package.

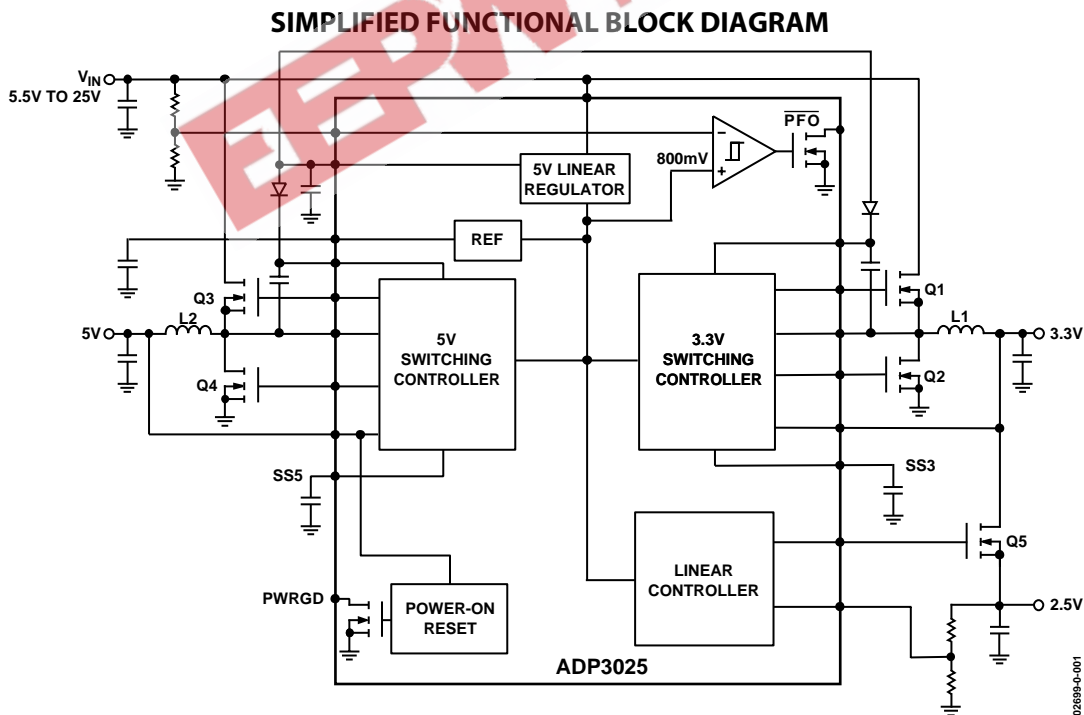

Figure 1.

Rev. A

Information furnished by Analog Devices is believed to be accurate and reliable. However, no responsibility is assumed by Analog Devices for its use, nor for any infringements of patents or other rights of third parties that may result from its use. Specifications subject to change without notice. No license is granted by implication or otherwise under any patent or patent rights of Analog Devices. Trademarks and registered trademarks are the property of their respective owners.

TABLE OF CONTENTS

Specifications.....	3	Output Voltage Adjustment	13
Absolute Maximum Ratings.....	5	Application Information	13
ESD Caution.....	5	Input Voltage Range	13
Pin Configuration and Function Descriptions.....	6	Maximum Output Current and MOSFET Selection	14
Typical Performance Characteristics	9	Nominal Inductor Value.....	15
Theory of Operation	11	Inductor Selection	15
Internal 5 V Supply (INTVCC)	11	C _{IN} and C _{OUT} Selection	16
Reference (REF).....	11	Power MOSFET Selection.....	16
Boosted High-Side Gate Drive Supply (BST)	11	Soft Start	17
Synchronous Rectifier (DRV1)	11	Fixed or Adjustable Output Voltage.....	17
Oscillator Frequency and Synchronization (SYNC).....	11	Efficiency Enhancement.....	17
Shutdown \overline{SD}	11	Transient Response Considerations.....	18
Soft Start and Power-Up Sequencing (SS)	11	Feedback Loop Compensation	18
Current Limiting (CLSET)	12	Compensation Loop Design and Test Method	19
Output Undervoltage Protection.....	12	Recommended Applications.....	19
Output Overvoltage and Reverse Voltage Protection.....	12	Layout Considerations.....	19
Power Good Output (PWRGD)	12	Outline Dimensions	21
Linear Regulator Controller.....	12	Ordering Guide	21

REVISION HISTORY

Revision A

4/04—Data Sheet changed from Rev. 0 to Rev. A

Change	Page
Changes to Features.....	1
Changes to Specifications	3
Changes to Figures 4 and 5.....	9
Changes to Theory of Operation section	11
Changes to Output Voltage Adjustment section	13
Changes to Table 5.....	13
Changes to Table 6.....	15
Changes to Table 8.....	16
Changes to Table 9.....	17

1/04—Revision 0: Initial Version

SPECIFICATIONS¹

Table 1. $T_A = 0^\circ\text{C}$ to 70°C , $V_{IN} = 12\text{ V}$, $SS5 = SS3 = \text{INTVCC}$, $\text{INTVCC Load} = 0\text{ mA}$, $\text{REF Load} = 0\text{ mA}$, $\text{SYNC} = 0\text{ V}$, $\overline{SD} = 5\text{ V}$, unless otherwise noted

Parameter	Symbol	Conditions	Min	Typ	Max	Unit
INTERNAL 5 V REGULATOR	INTVCC					
Input Voltage Range			5.5		25	V
Output Voltage		$T_A = 25^\circ\text{C}$	4.95	5.02	5.15	V
Line Regulation		$5.5\text{ V} \leq V_{IN} \leq 25\text{ V}$		1.0		mV/V
Total Variation		Full V_{IN} and temperature range	4.8		5.2	V
VIN Undervoltage Lockout	V_{UVLO}	INTVCC falling				
Threshold Voltage			4.05	4.25	4.5	V
Hysteresis				270		mV
REFERENCE	REF					
Output Voltage ²		$5.5\text{ V} \leq V_{IN} \leq 25\text{ V}$	784	800	816	mV
SUPPLY	I_Q					
Shutdown Current		$5.5\text{ V} \leq V_{IN} \leq 25\text{ V}$, $\overline{SD} = 0\text{ V}$		19	70	μA
Standby Current		$SS3 = SS5 = \text{COMP2}/\overline{SD2} = 0\text{ V}$, $\overline{SD} = 5\text{ V}$		120	200	μA
Quiescent Current		No loads, $SS3 = SS5 = \text{COMP2}/\overline{SD2} = 4\text{ V}$, $\text{FB5} = 810\text{ mV}$, $\text{FB3} = 810\text{ mV}$, $\text{FB2} = 810\text{ mV}$, $\text{ADJ}/\text{FX5} = \text{ADJ}/\text{FX3} = 5\text{ V}$		1.3	1.9	mA
OSCILLATOR	f_{osc}					
Frequency		$\text{SYNC} = \text{AGND}$, $5.5\text{ V} \leq V_{IN} \leq 25\text{ V}$	175	210	245	kHz
		$\text{SYNC} = \text{INTVCC}$, $5.5\text{ V} \leq V_{IN} \leq 25\text{ V}$	250	300	350	kHz
SYNC Input						
Frequency Range			230		350	kHz
Input Low Voltage ³		$t_f \leq 200\text{ ns}$			0.4	V
Input High Voltage ³		$t_r \leq 200\text{ ns}$	2.8			V
Input Current		$\text{SYNC} = 5\text{ V}$		0.5		μA
POWER GOOD	PWRGD					
Output Voltage in Regulation		10 k Ω pull-up to 5 V	4.8			V
Output Voltage out of Regulation		10 k Ω pull-up to 5 V, $\text{FB5} < 90\%$ of nominal output value			0.4	V
PWRGD Trip Threshold		FB5 rising; with respect to nominal output	-6.0	-3.7	-1.5	%
PWRGD Hysteresis		FB5 falling; with respect to nominal output		4		%
CPOR Pull-Up Current		$\text{CPOR} = 1.2\text{ V}$	-3.0	-1	-0.3	μA
ERROR AMPLIFIER						
DC Gain ³				47		dB
Gain-Bandwidth Product ³	GBW			10		MHz
Input Leakage Current	I_{EAN}	$\text{ADJ}/\overline{\text{FX5}} = \text{ADJ}/\overline{\text{FX3}} = 5\text{ V}$			200	nA

ADP3025

SPECIFICATIONS (continued)

Parameter	Symbol	Conditions	Min	Typ	Max	Unit
MAIN SMPS CONTROLLERS						
Fixed 5 V Output Voltage	FB5	$5.5 \text{ V} \leq \text{VIN} \leq 25 \text{ V}$, $\text{ADJ}/\overline{\text{FX5}} = 0 \text{ V}$	4.90	5.0	5.10	V
Fixed 3.3 V Output Voltage	FB3	$5.5 \text{ V} \leq \text{VIN} \leq 25 \text{ V}$, $\text{ADJ}/\overline{\text{FX3}} = 0 \text{ V}$	3.234	3.3	3.366	V
Adjustable Output Voltage	FB5, FB3	$5.5 \text{ V} \leq \text{VIN} \leq 25 \text{ V}$, $\text{ADJ}/\overline{\text{FX5}} = \text{ADJ}/\overline{\text{FX3}} = 5 \text{ V}$	776	800	824	mV
Output Voltage Adjustment Range ³		$\text{ADJ}/\overline{\text{FX5}} = \text{ADJ}/\overline{\text{FX3}} = 5 \text{ V}$	0.800		6.0	V
Current Limit Threshold						
CLSET5 = CLSET3 = Floating		$5.5 \text{ V} = \text{VIN} = 25 \text{ V}$, $T_A = 25^\circ\text{C}$	54	72	90	mV
CLSET5 = CLSET3 = 0 V		$5.5 \text{ V} \leq \text{VIN} \leq 25 \text{ V}$, $T_A = 25^\circ\text{C}$	240	300	360	mV
Soft Start Current		$\text{SS3} = \text{SS5} = 3 \text{ V}$	0.7	2.1	3.8	μA
Soft Start Turn-On Threshold	SS5, SS3		0.4	0.6	0.8	V
Feedback Input Leakage Current	I_{FB}	$\text{ADJ}/\overline{\text{FX5}} = \text{ADJ}/\overline{\text{FX3}} = 5 \text{ V}$, $\text{FB} = 800 \text{ mV}$			600	nA
Maximum Duty Cycle ³	D_{MAX}	$\text{VIN} = 5.5 \text{ V}$, $\text{SYNC} = \text{AGND}$	94	99		%
Transition Time (DRVL)						
Rise	$t_{\text{r}}(\text{DRVL})$	$C_{\text{LOAD}} = 3000 \text{ pF}$, 10% to 90%		40	70	ns
Fall	$t_{\text{f}}(\text{DRVL})$	$C_{\text{LOAD}} = 3000 \text{ pF}$, 90% to 10%		45	70	ns
Transition Time (DRVH)						
Rise	$t_{\text{r}}(\text{DRVH})$	$C_{\text{LOAD}} = 3000 \text{ pF}$, 10% to 90%		50	100	ns
Fall	$t_{\text{f}}(\text{DRVH})$	$C_{\text{LOAD}} = 3000 \text{ pF}$, 90% to 10%		50	100	ns
Logic Input Voltage						
ADJ/ $\overline{\text{FX3}}$, ADJ/ $\overline{\text{FX5}}$, $\overline{\text{SD}}$						
Logic Low	VIL				0.6	V
Logic High	VIH		2.9			V
LINEAR REGULATOR CONTROLLER						
Feedback Threshold	FB2		776	800	824	mV
COMP2/ $\overline{\text{SD2}}$ Pull-Up Current	COMP2/ $\overline{\text{SD2}}$	COMP2/ $\overline{\text{SD2}} = 0 \text{ V}$		2.8		μA
COMP2/ $\overline{\text{SD2}}$ Threshold			0.5	0.85	1.1	V
DC Gain ³				62		dB
Transconductance g_m ³		COMP2/ $\overline{\text{SD2}} = 3 \text{ V}$		0.3		ms
Gain-Bandwidth Product ³	GBW			20		MHz
FB2 Input Leakage Current	I_{FB2}	FB2 = 800 mV		20		nA
POWER-FAIL COMPARATOR						
PFI Input Threshold	PFI	$\overline{\text{PFO}}$ from high to low	776	800	824	mV
PFI Input Hysteresis				14		mV
PFI Input Current	I_{PFI}				500	nA
PFO High Voltage	$\overline{\text{PFO}}_{\text{H}}$	10 k Ω pull-up to 5 V	4.8			V
PFO Low Voltage	$\overline{\text{PFO}}_{\text{L}}$	10 k Ω pull-up to 5 V			0.4	V
FAULT PROTECTION						
Output Overvoltage Trip Threshold		With respect to nominal output	115	120	125	%
Output Undervoltage Lockout Threshold		With respect to nominal output	70	80	90	%

¹ All limits at temperature extremes are guaranteed via correlation using standard statistical quality control (SQC) methods.

² The reference's line regulation error is insignificant. The reference is not supposed to be loaded externally.

³ Guaranteed by design, not tested in production.

ABSOLUTE MAXIMUM RATINGS

Table 2. ADP3025 Stress Ratings

Parameter	Rating
VIN to AGND	-0.3 V to +27 V
AGND to PGND	±0.3 V
INTVCC	AGND - 0.3 V to +6 V
BST5, BST3 to PGND	-0.3 V to +32 V
BST5 to SW5	-0.3 V to +6 V
BST3 to SW3	-0.3 V to +6 V
CS5, CS3	AGND - 0.3 V to VIN
SW3, SW5 to PGND	-2 V to VIN + 0.3 V
\overline{SD}	AGND - 0.3 V to +27 V
DRVL5/3 to PGND	-0.3 V to INTVCC + 0.3 V
DRVH5/3 to SW5/3	-0.3 V to INTVCC + 0.3 V
All Other Inputs and Outputs	AGND - 0.3 V to INTVCC + 0.3 V
θ_{JA}	98°C/W
Operating Ambient Temperature Range	0°C to 70°C
Junction Temperature Range	0°C to 150°C
Storage Temperature Range	-65°C to +150°C
Lead Temperature Range (Soldering 10 sec)	300°C

Stresses above those listed under Absolute Maximum Ratings may cause permanent damage to the device. This is a stress rating only; functional operation of the device at these or any other conditions above those listed in the operational sections of this specification is not implied. Exposure to absolute maximum rating conditions for extended periods may affect device reliability.

ESD CAUTION

ESD (electrostatic discharge) sensitive device. Electrostatic charges as high as 4000 V readily accumulate on the human body and test equipment and can discharge without detection. Although this product features proprietary ESD protection circuitry, permanent damage may occur on devices subjected to high energy electrostatic discharges. Therefore, proper ESD precautions are recommended to avoid performance degradation or loss of functionality.



PIN CONFIGURATION AND FUNCTION DESCRIPTIONS

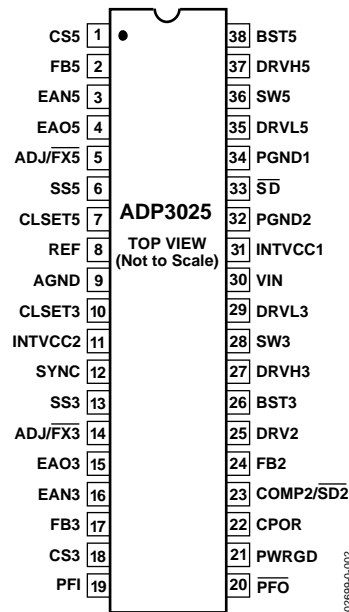

Figure 2. 38-Lead TSSOP Pin Configuration

Table 3. Pin Function Descriptions

Pin No.	Mnemonic	Function
1	CS5	Current Sense Input for the Top N-Channel MOSFET of the 5 V Buck Converter. Connect to the drain of the top N-channel MOSFET.
2	FB5	Feedback Input for the 5 V Buck Converter. Connect to the output sense point in fixed output mode. Connect to an external resistor divider in adjustable output mode.
3	EAN5	Inverting Input of the Error Amplifier of the 5 V Buck Converter. Use for external loop compensation only in fixed output mode. In adjustable output mode, connect to the external resistor divider.
4	EA05	Error Amplifier Output for the 5 V Buck Converter.
5	ADJ/ $\overline{\text{FX5}}$	TTL Logic Input. When ADJ/ $\overline{\text{FX5}}$ = 0 V, fixed output mode, connect FB5 to the output sense point. When ADJ/ $\overline{\text{FX5}}$ = 5 V, adjustable output mode, connect FB5 to the external resistor divider.
6	SS5	Soft Start for the 5 V Buck Converter. Also used as an ON/OFF pin.
7	CLSET5	Current Limit Setting. A resistor can be connected from AGND to CLSET5. A minimum current limit is obtained by leaving it open. A maximum current limit is obtained by connecting it to AGND.
8	REF	800 mV Reference. Bypass it with a capacitor (22 nF typical) to AGND. REF cannot be loaded externally.
9	AGND	Analog Signal Ground.
10	CLSET3	Current Limit Setting. A resistor can be connected from AGND to CLSET3. A minimum current limit is obtained by leaving it open. A maximum current limit is obtained by connecting it to AGND.
11, 31	INTVCC2, 1	Linear Regulator Bypass for the Internal 5 V LDO. Bypass this pin with a 4.7 μ F capacitor to AGND. Pins 11 and 31 must be connected for proper operation.
12	SYNC	Oscillator Synchronization and Frequency Select. $f_{\text{OSC}} = 200$ kHz when SYNC = 0 V; select $f_{\text{OSC}} = 300$ kHz, when SYNC = 5 V. The oscillator can be synchronized with an external source through the SYNC pin.
13	SS3	Soft Start for the 3.3 V Buck Converter. Also used as an ON/OFF pin.
14	ADJ/ $\overline{\text{FX3}}$	TTL Logic Input. When ADJ/ $\overline{\text{FX3}}$ = 0 V, fixed output mode, connect FB3 to the output sense point. When ADJ/ $\overline{\text{FX3}}$ = 5 V, adjustable output mode, connect FB3 to the external resistor divider.
15	EA03	Error Amplifier Output for the 3.3 V Buck Converter.
16	EAN3	Error Amplifier Inverting Input of the 3.3 V Buck Converter. Use for external loop compensation only in fixed output mode. In adjustable output mode, connect to an external resistor divider.
17	FB3	Feedback Input for the 3.3 V Buck Converter. Connect to output sense point in fixed output mode. Connect to an external resistor divider in adjustable output mode.
18	CS3	Current Sense Input for the Top N-Channel MOSFET of the 3.3 V Buck Converter. CS3 should be connected to the drain of the N-channel MOSFET.

Pin No.	Mnemonic	Function
19	PFI	Negative Input of a Comparator that can be Used as a Power-Fail Detector. The positive input is connected to the 800 mV reference. There is a 14 mV hysteresis for this comparator.
20	$\overline{\text{PFO}}$	Power Failure Output, Open Drain Output. This pin sinks current when the PFI pin is lower than 800 mV. Otherwise, $\overline{\text{PFO}}$ is floating.
21	PWRGD	Power Good Output. PWRGD goes low with no delay whenever the 5 V output drops 7% below its nominal value. When the 5 V output is within -3% of its nominal value, PWRGD is released after a time delay determined by the timing capacitor on the CPOR pin.
22	CPOR	Power-On Reset Capacitor. Connect a capacitor between CPOR and AGND to set the delay time for the PWRGD pin. A 1 μA pull-up current is used to charge the capacitor. A manual reset ($\overline{\text{MR}}$) function can also be achieved by pulling this pin low.
23	COMP2/ $\overline{\text{SD2}}$	Compensation Input for the Linear Regulator Controller. Connect an RC network to GND for stable operation. This pin is also used as an ON/OFF pin of the linear regulator controller.
24	FB2	Feedback for the Linear Regulator Controller.
25	DRV2	NMOS Gate Drive Output for the Linear Regulator Controller.
26	BST3	Boost Capacitor Connection for High-Side Driver of the 3.3 V Buck Converter.
27	DRVH3	High-Side Gate Drive for the 3.3 V Buck Converter.
28	SW3	Switching Node (Inductor) Connection of the 3.3 V Buck Converter.
29	DRVL3	Low-Side Gate Drive of the 3.3 V Buck Converter.
30	VIN	Main Supply Input (5.5 V to 25 V).
32, 34	PGND2, 1	Power Ground. Pins 32 and 34 must be connected together for proper operation.
33	$\overline{\text{SD}}$	Shutdown Control Input, Active Low. If $\overline{\text{SD}} = 0\text{ V}$, the chip is in shutdown mode with very low quiescent current. For automatic startup, connect $\overline{\text{SD}}$ to VIN via a resistor.
35	DRVL5	Low-Side Gate Drive for the 5 V Buck Converter.
36	SW5	Switching Node (Inductor) Connection for the 5 V Buck Converter.
37	DRVH5	High-Side Gate Drive for the 5 V Buck Converter.
38	BST5	Boost Capacitor Connection for the High-Side Driver of the 5 V Buck Converter.

ADP3025

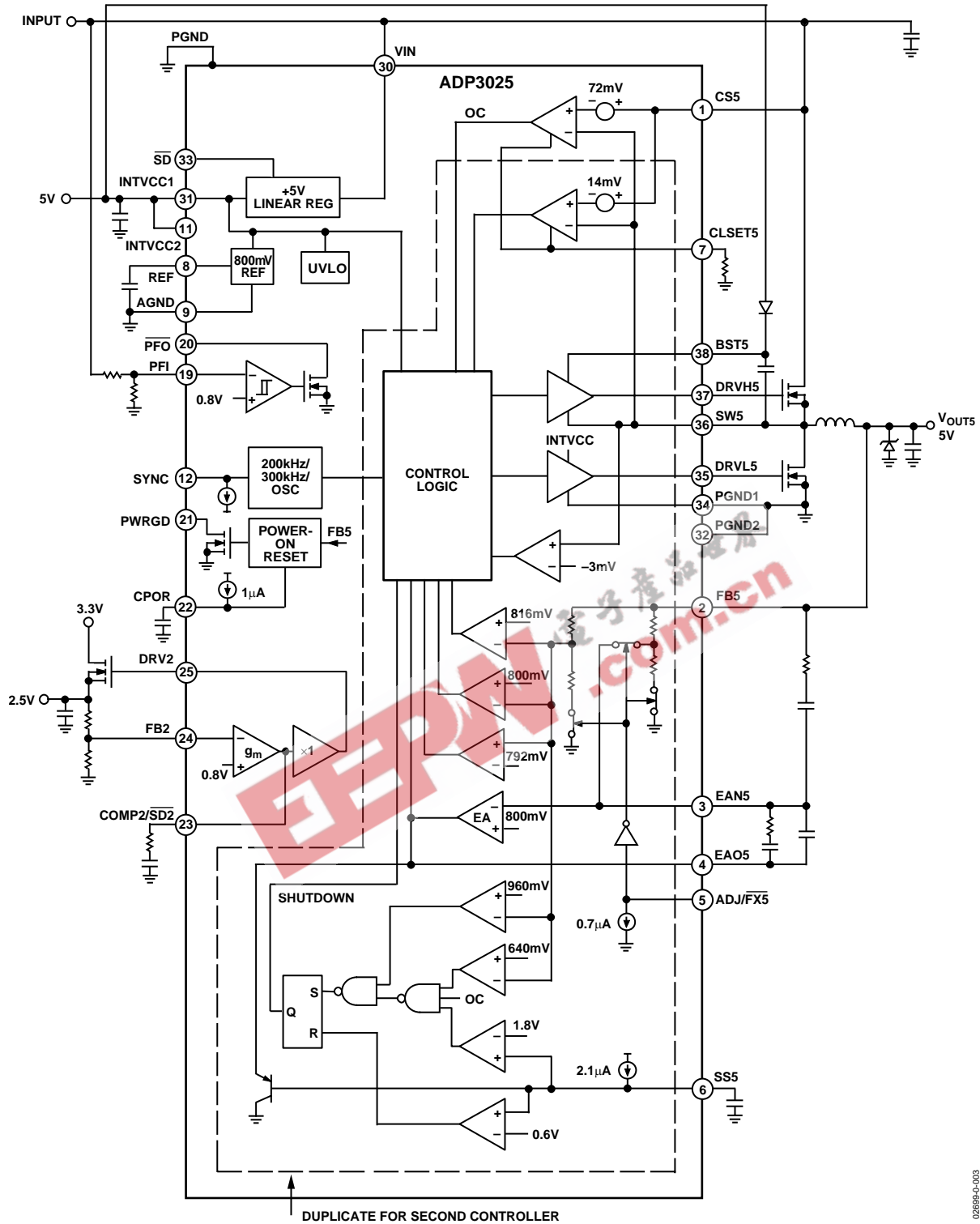

Figure 3. Block Diagram (All Switches and Components Shown for Fixed Output Operation)

02699A-0-003

TYPICAL PERFORMANCE CHARACTERISTICS

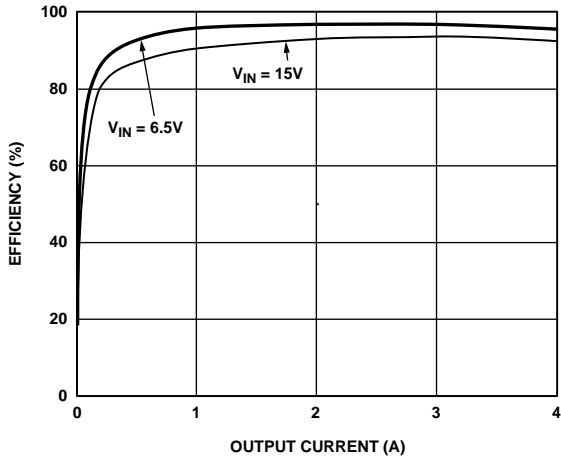

Figure 4. Efficiency vs. 5 V Output Current

026899-0-004

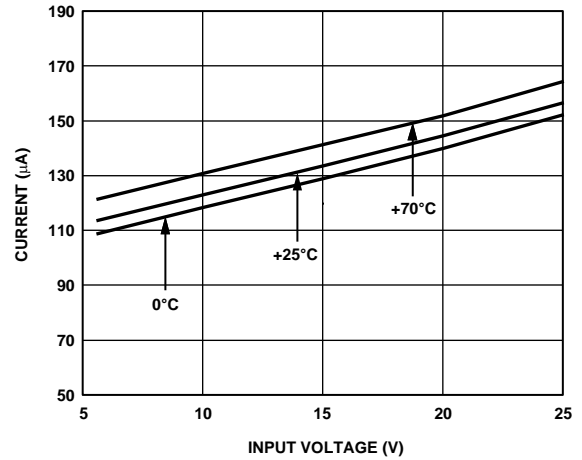

Figure 7. Input Standby Current vs. Input Voltage

026899-0-007

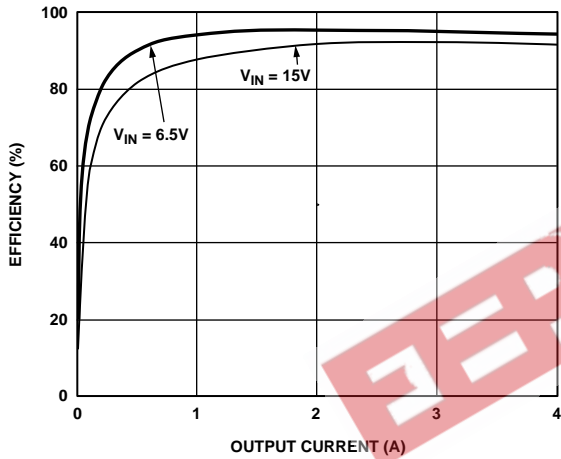

Figure 5. Efficiency vs. 3.3 V Output Current

026899-0-005

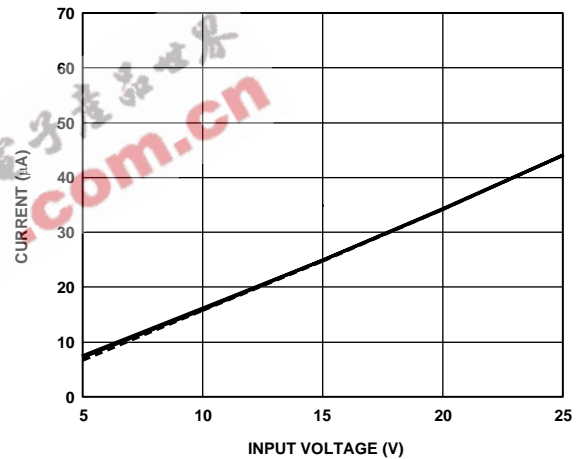

Figure 8. Input Shutdown Current vs. Input Voltage

026899-0-008

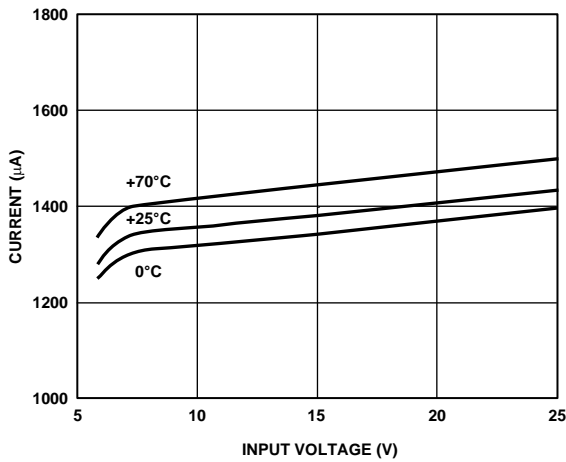

Figure 6. Input Current vs. Input Voltage

026899-0-006

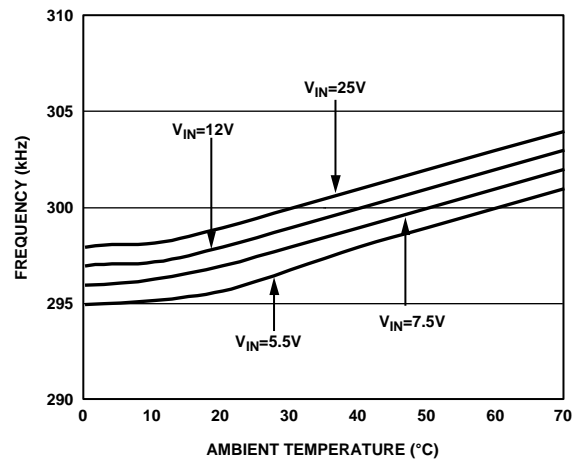

Figure 9. Oscillator Frequency vs. Temperature

026899-0-009

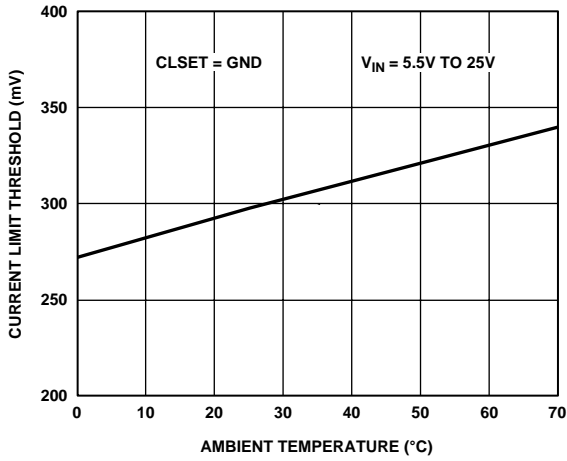

Figure 10. Current Limit Threshold vs. Temperature

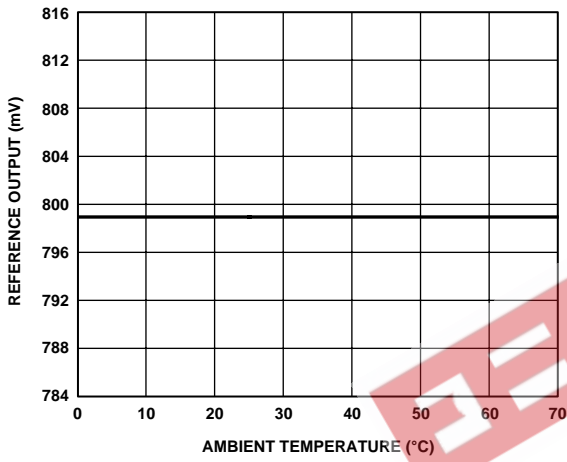

Figure 11. Reference Output vs. Temperature

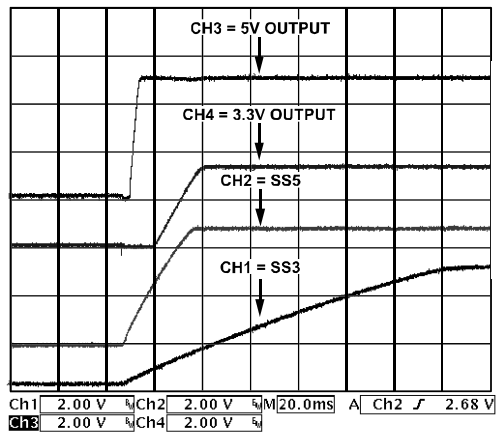

Figure 12. Soft Start Sequencing

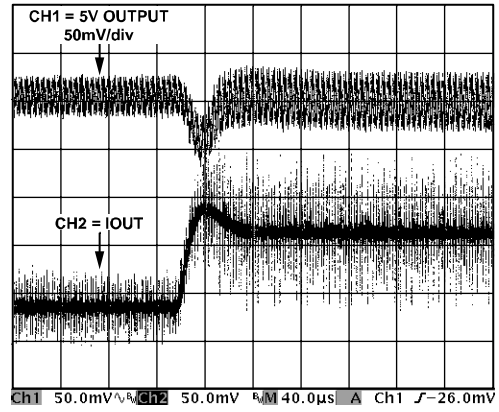

Figure 13. Load Transient Response—1 A to 3 A

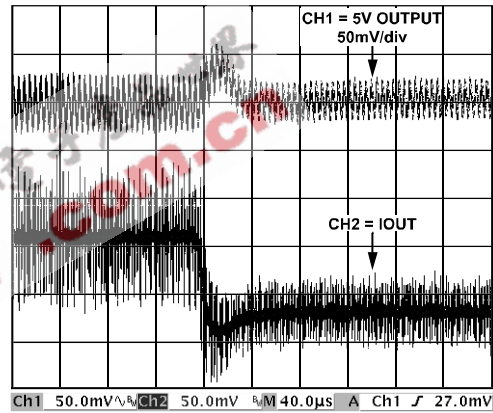

Figure 14. Load Transient Response—3 A to 1 A

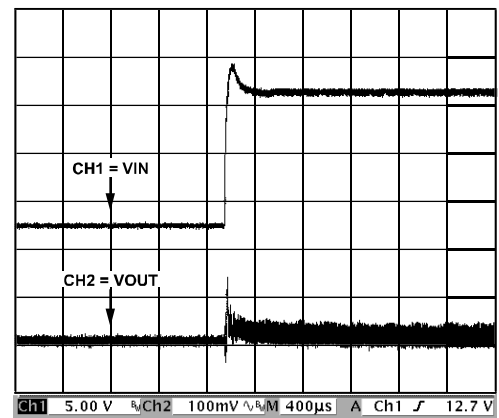

Figure 15. $V_{IN} = 7.5 \text{ V to } 22 \text{ V}$ Transient, 2.5 V Output, CH1—Input Voltage, CH2—Output Voltage

THEORY OF OPERATION

The ADP3025 contains two synchronous step-down buck controllers and a linear regulator controller. The buck controllers in the ADP3025 have the ability to provide either fixed 3.3 V and 5 V outputs or independently adjustable (800 mV to 6.0 V) outputs. Efficiency is improved by eliminating the external current sense resistor, which is the main contributor to loss during high current, low output voltage conditions.

INTERNAL 5 V SUPPLY (INTVCC)

An internal low dropout regulator (LDO) generates a 5 V supply (INTVCC) that powers all the functional blocks within the IC. The total current rating of this LDO is 50 mA. However, this current is used for supplying gate drive power; current should not be drawn from this pin for other purposes. Bypass INTVCC to AGND with a 4.7 μ F capacitor. A UVLO circuit is also included in the regulator. When $INTVCC < 4.05$ V, the two switching regulators and the linear regulator controller are shut down. The UVLO hysteresis voltage is about 300 mV. The internal LDO has a built-in foldback current limit so that it is protected if a short circuit is applied to the 5 V output.

REFERENCE (REF)

The ADP3025 contains a precision 800 mV reference. Bypass REF to AGND with a 22 nF ceramic capacitor. The reference is intended for internal use only.

BOOSTED HIGH-SIDE GATE DRIVE SUPPLY (BST)

The gate drive voltage for the high-side N-channel MOSFET is generated by a flying-capacitor boost circuit. The boost capacitor connected between BST and SW is charged from the INTVCC supply. Use only small-signal diodes for the boost circuit.

SYNCHRONOUS RECTIFIER (DRVL)

Synchronous rectification is used to reduce conduction losses and ensure proper startup of the boost gate driver circuit. Antishoot-through protection has been included to prevent

cross-conduction during switch transitions. The low-side driver must be turned off before the high-side driver is turned on. For typical N-channel MOSFETs, the dead time is approximately 50 ns. On the other edge, a dead time of approximately 50 ns is achieved by an internal delay circuit. In discontinuous conduction mode (DCM), the synchronous rectifier is turned off when the current flowing through the low-side MOSFET falls to zero. In continuous conduction mode (CCM), the current flowing through the low-side MOSFET never reaches zero, so the synchronous rectifier is turned off by the next clock cycle.

OSCILLATOR FREQUENCY AND SYNCHRONIZATION (SYNC)

The SYNC pin controls the oscillator frequency. When $SYNC = 0$ V, $f_{osc} = 200$ kHz; when $SYNC = 5$ V, $f_{osc} = 300$ kHz. 300 kHz operation minimizes external component size and cost; 200 kHz operation provides better efficiency and lower dropout. The SYNC pin can also be used to synchronize the oscillator with an external 5 V clock signal. A low-to-high transition on SYNC initiates a new cycle. The synchronization range is 230 kHz to 350 kHz.

SHUTDOWN \overline{SD}

Holding \overline{SD} low puts the ADP3025 into ultralow current shutdown mode. For automatic startup, \overline{SD} can be tied to VIN via a resistor.

SOFT START AND POWER-UP SEQUENCING (SS)

SS3 and SS5 are soft start pins for the two controllers. A 2 μ A pull-up current is used to charge an external soft start capacitor. Power-up sequencing can easily be done by choosing different capacitance. When $SS3/SS5 < 0.6$ V, the two switching regulators are turned off. When 0.6 V $< SS3/SS5 < 1.8$ V, the regulators start working in soft start mode. When $SS3/SS5 > 1.8$ V, the regulators are in normal operating mode. The minimum soft start time (~ 20 μ s) is set by an internal capacitor. Table 4 shows the ADP3025 operating modes.

Table 4. Operating Modes

\overline{SD}	SS5	SS3	Description
Low			All Circuits Turned Off
High	$SS5 < 0.6$ V	$SS3 < 0.6$ V	5 V and 3.3 V Off; INTVCC = 5 V, REF = 800 mV
High	0.6 V $< SS5 < 1.8$ V		5 V in Soft Start
High	1.8 V $< SS5$		5 V in Normal Operation
High		0.6 V $< SS3 < 1.8$ V	3.3 V in Soft Start
High		1.8 V $< SS3$	3.3 V in Normal Operation

CURRENT LIMITING (CLSET)

A cycle-by-cycle current limiting scheme is used by monitoring current through the top N-channel MOSFET when it is turned on. By measuring the voltage drop across the high-side MOSFET, $V_{DS(ON)}$, the use of an external sense resistor can be omitted. The current limit value can be set by CLSET. When CLSET is floating, the maximum $V_{DS(ON)} = 72$ mV at room temperature; when CLSET = 0 V, the maximum $V_{DS(ON)} = 300$ mV at room temperature. An external resistor can be connected between CLSET and AGND to choose a value between 72 mV and 300 mV. The relationship between the external resistance and the maximum $V_{DS(ON)}$ is

$$V_{DS(ON)MAX} = 72 \text{ mV} \frac{(110 \text{ k}\Omega + R_{EXT})}{(26 \text{ k}\Omega + R_{EXT})} \quad (1)$$

The temperature coefficient of $R_{DS(ON)}$ of the N-channel MOSFET is canceled by the internal current limit circuitry, so an accurate current limit value can be obtained over a wide temperature range.

OUTPUT UNDERVOLTAGE PROTECTION

Each switching controller has an undervoltage protection circuit. When the current flowing through the high-side MOSFET reaches the current limit continuously for eight clock cycles and the output voltage stays below 20% of the nominal output voltage, both controllers are latched off and do not restart until \overline{SD} or SS3/SS5 is toggled, or until V_{IN} is cycled below 4.05 V. This feature is disabled during soft start.

OUTPUT OVERVOLTAGE AND REVERSE VOLTAGE PROTECTION

Both converter outputs are continuously monitored for overvoltage. If either output voltage is higher than the nominal output voltage by more than 20%, both converters' high-side gate drivers (DRVH5/3) are latched off, and the low-side gate drivers are latched on. The chip will not restart until \overline{SD} or SS5/SS3 is toggled, or until V_{IN} is cycled below 4.05 V. The low-side gate driver (DRV1) is kept high when the controller is in the off-state and the output voltage is less than 93% of the nominal output voltage. Discharging the output capacitors through the main inductor and low-side N-channel MOSFET causes the output to ring. This makes the output go below GND momentarily. To prevent damage to the circuit, use a 1 A Schottky diode in parallel with the output capacitors to clamp the negative surge.

POWER GOOD OUTPUT (PWRGD)

The ADP3025 also provides a PWRGD signal output. During startup, the PWRGD pin is held low until the 5 V output is within -3% of its preset voltage. Then, after a time delay determined by an external timing capacitor connected from CPOR to GND, PWRGD is actively pulled up to INTVCC by an external pull-up resistor. This delay can be calculated by

$$t_D = \frac{1.2 \text{ V} \times C_{CPOR}}{1 \mu\text{A}} \quad (2)$$

CPOR can also be used as a manual reset (\overline{MR}) input. When the 5 V output is lower than the preset voltage by more than 7%, PWRGD is immediately pulled low.

LINEAR REGULATOR CONTROLLER

The ADP3025 includes an on-board linear regulator controller. An external NMOS can be used as the pass transistor. The output voltage can be set by a resistor divider. The minimum output voltage of the LDO is 800 mV, while the maximum output voltage cannot exceed a voltage level determined by the IC's INTVCC voltage minus the threshold voltage of the external N-type MOSFET device. Assuming a INTVCC of 5 V, the recommended maximum output voltage is around 2.5 V. To ensure loop stability, a compensation network can be attached to the COMP2/ $\overline{SD2}$ pin, as shown in Figure 17.

Large signal response limits the maximum/minimum load ratio. When the linear regulator is loaded, the MOSFET's gate source voltage is at its threshold level and changes only slightly. The loop response speed depends on the loop transfer function, which is fast enough for most applications. However, when the load is extremely light, the gate source voltage of the MOSFET is much lower than its nominal value. If at this moment the load increases suddenly, the MOSFET's gate source capacitance needs to be charged up, which takes time. To optimize large signal response, not exceeding a maximum-to-minimum load ratio of 100 to 1 is recommended.

OUTPUT VOLTAGE ADJUSTMENT

Fixed output voltages (5 V/3.3 V) are selected when $\overline{ADJ}/\overline{FX5} = \overline{ADJ}/\overline{FX3} = 0$ V. The output voltage of each controller can also be set by an external feedback resistor network when $\overline{ADJ}/\overline{FX5} = \overline{ADJ}/\overline{FX3} = 5$ V, as shown in Figure 16. There should be two external feedback resistor dividers for each controller, one for the voltage feedback loop and one for the output voltage monitor. Both resistor dividers must be identical. The minimum output voltage is 800 mV, and the maximum output voltage is 6.0 V.

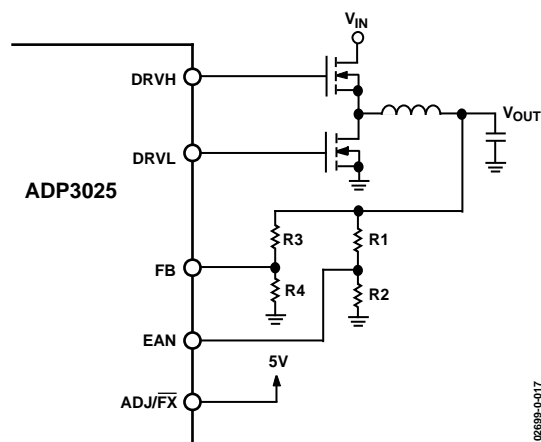

Figure 16. Adjustable Output Mode

The output voltage can be calculated using the following formula:

$$V_{OUT} = 800 \text{ mV} \times \left(1 + \frac{R1}{R2}\right) \quad (3)$$

where $R1/R2 = R3/R4$.

If the loop is carefully compensated, R3 and R4 can be removed and FB and EAN can be tied together.

APPLICATION INFORMATION

A typical application circuit using the ADP3025 is shown in Figure 17. Although the component values given in Figure 17 are based on a 5 V @ 4 A/3.3 V @ 4 A/2.5 V @ 1.5 A design, the ADP3025 output drivers are capable of handling output currents anywhere from <1 A to over 10 A. Throughout this section, design examples and component values are given for three different power levels. For simplicity, these levels are referred to as low power and basic power. Table 5 shows the input/output specifications for these three levels.

Table 5. Typical Power Level Examples

	Low Power	Basic
Input Voltage Range	5.5 V to 25 V	5.5 V to 25 V
Switching Output 1	3.3 V/2 A	3.3 V/4 A
Switching Output 2	5 V/2 A	5 V/4 A
Linear Output	2.5 V/1 A	2.5 V/1.5 A

INPUT VOLTAGE RANGE

The input voltage range of the ADP3025 is 5.5 V to 25 V. The converter design is optimized to deliver the best performance within a 7.5 V to 18 V range, which is the nominal voltage for three to four cell Li-Ion battery stacks. Voltages above 18 V may occur under light loads and when the system is powered from an ac adapter with no battery installed.

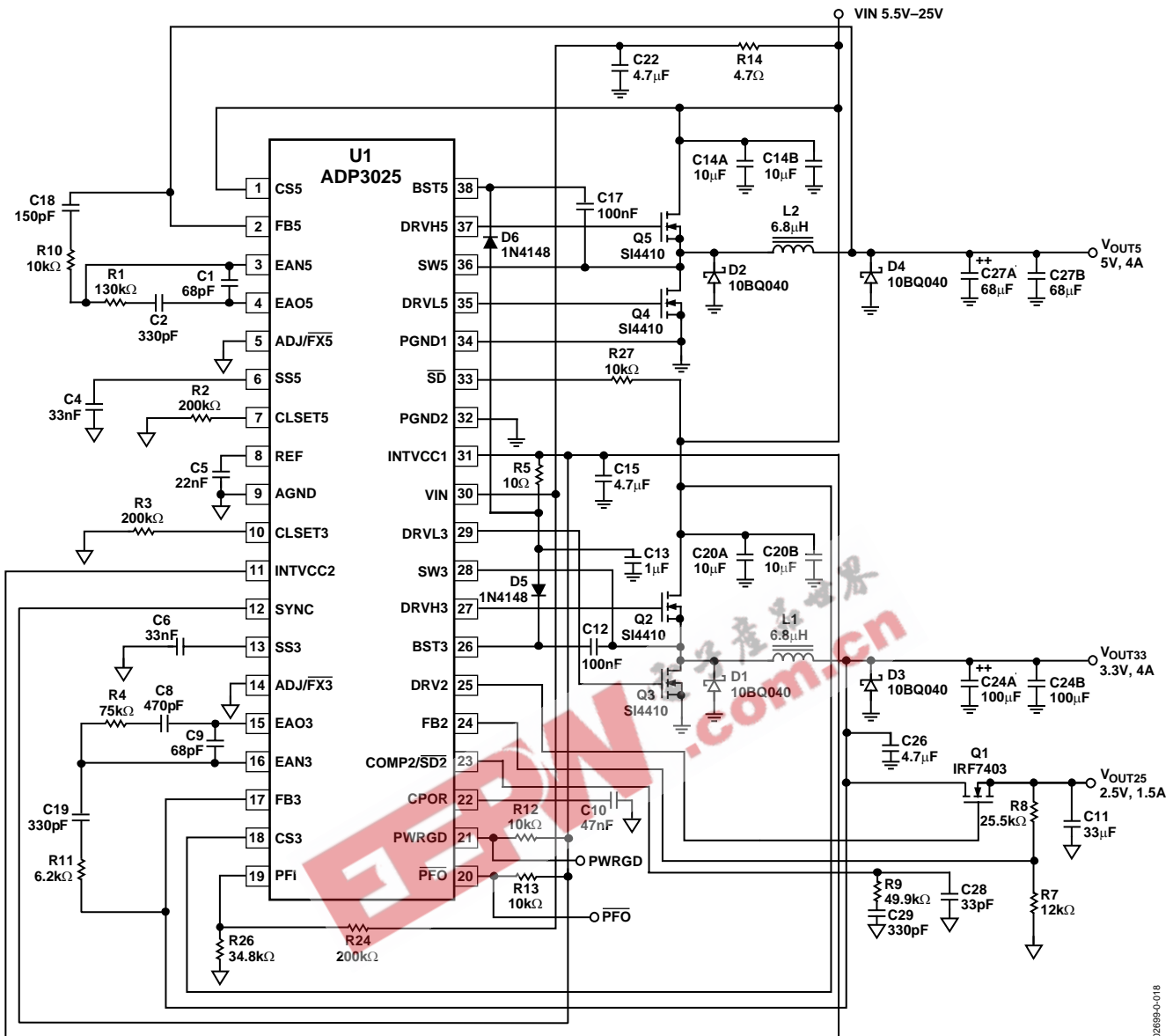

Figure 17. 45 W, Triple Output DC-to-DC Converter

MAXIMUM OUTPUT CURRENT AND MOSFET SELECTION

The maximum output current for each switching regulator is limited by sensing the voltage drop between the drain and source of the high-side MOSFET when it is turned on. A current sense comparator senses voltage drop between CS5 and SW5 for the 5 V converter and between CS3 and SW3 for the 3.3 V converter. The sense comparator threshold is 72 mV when the programming pin CLSET is floating, and 300 mV when CLSET is connected to ground. Current limiting is based on sensing the peak current. Peak current varies with input voltage and depends on the inductor value. The higher the ripple current or input voltage, the lower the converter maximum output current at the set current sense amplifier threshold. The relation between peak and dc output current is given by

$$I_{PEAK} = I_{OUT} + V_{OUT} \times \left(\frac{V_{IN(MAX)} - V_{OUT}}{2 \times f \times L \times V_{IN(MAX)}} \right) \quad (4)$$

At a given current comparator threshold, V_{TH} and MOSFET $R_{DS(ON)}$, the maximum inductor peak current is

$$I_{PEAK} = \frac{V_{TH}}{R_{DS(ON)}} \quad (5)$$

Rearranging Equation 2 to solve for $I_{OUT(MAX)}$ gives

$$I_{OUT(MAX)} = \frac{V_{TH}}{R_{DS(ON)}} - V_{OUT} \times \left(\frac{V_{IN(MAX)} - V_{OUT}}{2 \times f \times L \times V_{IN(MAX)}} \right) \quad (6)$$

V_{TH} can be chosen to accommodate $I_{OUT(MAX)}$.

This current limit circuit is designed to protect against high current or short-circuit conditions only. This protects the IC and MOSFETs long enough to allow the output undervoltage protection circuitry to latch off the supply.

NOMINAL INDUCTOR VALUE

Inductor design is based on the assumption that the inductor ripple current is 30% of the maximum output dc current at a nominal 12 V input voltage. The inductor ripple current and inductance values are not critical, but are important in analyzing the trade-offs between cost, size, efficiency, and volume. The higher the ripple current, the lower the inductor size and volume. However, this leads to higher ac losses in the windings. Conversely, a higher inductor value means lower ripple current and smaller output filter capacitors, as well as slower transient response.

The inductor design should be based on the maximum output current plus 15% (½ of the 30% ripple allowance) at the nominal input voltage:

$$L \geq 3 \times (V_{IN(NOM)} - V_{OUT}) \times \frac{V_{OUT}}{f \times I_{OUT(MAX)} \times V_{IN(NOM)}} \quad (7)$$

Optimum standard inductor values for various output voltage and current levels are shown in Table 6.

Table 6. Standard Inductor Values

Frequency (kHz)	3.3 V/2 A	3.3 V/4 A	5 V/2 A	5 V/4 A
200	20 µH	8.2 µH	22 µH	10 µH
300	12 µH	6.8 µH	15 µH	8.2 µH

INDUCTOR SELECTION

Once the value for the inductor is known, there are two ways to proceed: design the inductor in-house or buy the closest inductor that meets the overall design goals.

Standard Inductors

Buying a standard inductor provides the fastest, easiest solution. Many companies offer suitable power inductor solutions. A list of power inductor manufacturers is given in Table 7.

Table 7. Recommended Inductor Manufacturers

Coilcraft	Coiltronics	Murata Electronics North America, Inc.
Phone: 847/639-6400 Fax: 847/639-1469 Web: www.coilcraft.com SMT Power Inductors, Series 1608, 3308, 3316, 5022, 5022HC, DO3340, Low Cost Solution SMT Shielded Power Inductors Series DS5022, DS3316, DT3316, Best for Low EMI/RFI Power Inductors and Chokes, Series DC1012, PCV-0, PCV-1, PCV-2, PCH-27, PCH-45, Low Cost	Phone: 561/241-7876 Fax: 561/241-9339 Web: www.coiltronics.com SMT Power Inductors, Series UNI-PAC2, UNI-PAC3 and UNI-PAC4, Low Cost Solution SMT Power Inductors, Series, ECONO-PAC, VERSA-PAC, Best for Low Profile or Flexible Design Power Inductors CTX Series, Low EMI/RFI, Low Cost Toroidal Inductors but not Miniature	Phone: 770/436-1300 Fax: 770/436-3030 Web: www.murata.com SMT Power Inductors, Series LQT2535. Best for Low EMI/RFI Chip Inductors LQN6C, LQS66C

C_{IN} AND C_{OUT} SELECTION

In continuous conduction mode, the source current of the upper MOSFET is approximately a square wave of duty cycle V_{OUT}/V_{IN} . To prevent large voltage transients, a low ESR input capacitor sized for the maximum rms current must be used. The maximum rms capacitor current is

$$I_{RMS} = \sqrt{V_{OUT} \times (V_{IN} - V_{OUT})} \times \frac{I_{OUT(MAX)}}{V_{IN}} \quad (8)$$

This formula has a maximum at $V_{IN} = 2 V_{OUT}$, where $I_{RMS} = I_{OUT(MAX)}/2$. Note that the capacitor manufacturer's ripple current ratings are often based on only 2,000 hours of life. Therefore, the user should further derate the capacitor, or choose one rated at a higher temperature than required. Several capacitors may be paralleled to meet size or height requirements in the design. If electrolytic or tantalum capacitors are used, an additional 0.1 μ F to 1 μ F ceramic bypass capacitor should be placed in parallel with C_{IN} .

The selection of C_{OUT} is driven by the required effective series resistance (ESR) and the desired output ripple. A good practice is to limit the ripple voltage to 1% of the nominal output voltage. It is assumed that the total ripple is caused by two factors: 25% comes from the C_{OUT} bulk capacitance value, and 75% comes from the capacitor ESR. The value of C_{OUT} can be determined by

$$C_{OUT} = \frac{I_{RIPPLE}}{2 \times f \times V_{RIPPLE}} \quad (9)$$

where $I_{RIPPLE} = 0.3 I_{OUT}$ and $V_{RIPPLE} = 0.01 V_{OUT}$. The maximum acceptable ESR of C_{OUT} can then be found using

$$ESR \leq 0.75 \times \frac{V_{RIPPLE}}{I_{RIPPLE}} \quad (10)$$

Manufacturers such as Vishay, AVX, Elna, WIMA, and Sanyo provide good high performance capacitors. Sanyo's OSCON semiconductor dielectric capacitors have lower ESR for a given size, at a somewhat higher price. Choosing sufficient capacitors to meet the ESR requirement for C_{OUT} normally exceeds the amount of capacitance needed to meet the ripple current requirement.

In surface-mount applications, multiple capacitors may have to be paralleled to meet the capacitance, ESR, or rms current handling requirements. Aluminum electrolytic and dry tantalum capacitors are available in surface-mount configurations. In the case of tantalum, it is critical that capacitors be surge tested for use in switching power supplies. Recommendations for output capacitors are shown in Table 8.

POWER MOSFET SELECTION

N-channel power MOSFETs must be selected for use with the ADP3025 for the main and synchronous switches. The main selection parameters for the power MOSFETs are the threshold voltage ($V_{GS(TH)}$) and on resistance ($R_{DS(ON)}$). An internal LDO generates a 5 V supply that is boosted above the input voltage by using a bootstrap circuit. This floating 5 V supply is used for the upper MOSFET gate drive. Logic-level threshold MOSFETs must be used for both the main and synchronous switches.

Maximum output current (I_{MAX}) determines the $R_{DS(ON)}$ requirement for the two power MOSFETs. When the ADP3025 is operating in continuous mode, the simplifying assumption can be made that one of the two MOSFETs is always conducting the load current. The duty cycles for the MOSFETs are given by

$$\text{Upper MOSFET DutyCycle} = \frac{V_{OUT}}{V_{IN}} \quad (11)$$

$$\text{Lower MOSFET DutyCycle} = \frac{V_{IN} - V_{OUT}}{V_{IN}} \quad (12)$$

Table 8. Recommended Capacitor Manufacturers

Maximum Output Current	2 A	4 A
Input Capacitors	TOKIN Multilayer Ceramic Caps, 22 μ F/25 V P/N: C55Y5U1E226Z TAIYO YUDEN INC. Ceramic Caps, Y5V Series 10 μ F/25 V P/N: TMK432BJ106KM	TOKIN Multilayer Ceramic Caps, 2 \times 22 μ F/25 V P/N: C55Y5U1E226Z TAIYO YUDEN INC. Ceramic Caps, Y5V Series 2 \times 10 μ F/25 V P/N: TMK432BJ106KM
Output Capacitors 3.3 V Output	SANYO POSCAP TPC Series, 68 μ F/10 V	SANYO POSCAP TPC Series, 2 \times 68 μ F/10 V
Output Capacitors 5 V Output	SANYO POSCAP TPC Series, 68 μ F/10 V	SANYO POSCAP TPC Series, 2 \times 68 μ F/10 V

From the duty cycle, the required minimum $R_{DS(ON)}$ for each MOSFET can be derived by the following equations:

Upper MOSFET:

$$R_{DS(ON)}(UPPER) = \frac{V_{IN} \times P_D}{V_{OUT} \times I_{MAX}^2 \times (1 + \alpha \Delta T)} \quad (13)$$

Lower MOSFET:

$$R_{DS(ON)}(LOWER) = \frac{V_{IN} \times P_D}{(V_{IN} - V_{OUT}) \times I_{MAX}^2 \times (1 + \alpha \Delta T)} \quad (14)$$

where P_D is the allowable power dissipation and α is the temperature dependency of $R_{DS(ON)}$. P_D is determined by efficiency and/or thermal requirements (see the Efficiency Enhancement section). $(1 + \alpha \Delta T)$ is generally given for a MOSFET in the form of a normalized $R_{DS(ON)}$ versus temperature curve, but $\alpha = 0.007/^\circ\text{C}$ can be used as an approximation for low voltage MOSFETs.

Maximum MOSFET power dissipation occurs at maximum output current and can be calculated as follows:

Upper MOSFET:

$$P_D(UPPER) = \frac{V_{OUT}}{V_{IN}} \times I_{MAX}^2 \times R_{DS(ON)} \times (1 + \alpha \Delta T) \quad (15)$$

Lower MOSFET:

$$P_D(LOWER) = \frac{V_{IN} - V_{OUT}}{V_{IN}} \times I_{MAX}^2 \times R_{DS(ON)} \times (1 + \alpha \Delta T) \quad (16)$$

The Schottky diode, D1 in Figure 17, conducts only during the dead time between conduction of the two power MOSFETs. D1's purpose is to prevent the body diode of the lower N-channel MOSFET from turning on and storing charge during the dead time, which could cost as much as 1% in efficiency. D1 should be selected for forward voltage of less than 0.5 V when conducting I_{MAX} . Recommended transistors for upper and lower MOSFETs are given in Table 9.

Table 9. Recommended MOSFETs

Maximum Output	2 A	4 A
Vishay/Siliconix	Si4412DY, 28 mΩ	Si4410DY, 13.5 mΩ
International Rectifier	IRF7805, 11 mΩ	IRF7811, 8.9 mΩ RF7805, 11 mΩ

SOFT START

The soft start time of each of the switching regulators can be programmed by connecting a soft start capacitor to the corresponding soft start pin (SS3 or SS5). The time it takes each regulator to ramp up to its full duty ratio depends proportionally on the values of the soft start capacitors. The charging current is $2.5 \mu\text{A} \pm 20\%$. The capacitor value to set a given soft start time, t_{SS} , is given by

$$C_{SS} \cong 2.5 \mu\text{A} \times \frac{t_{SS}(\mu\text{s})}{1.8 \text{ V}} (\text{pF}) \quad (17)$$

FIXED OR ADJUSTABLE OUTPUT VOLTAGE

Each of the ADP3025's switching controllers can be programmed to operate with a fixed or adjustable output voltage. As shown in Figure 17, putting the ADP3025 into fixed mode gives a nominal output of 3.3 V and 5 V for the two switching buck converters. By using two identical resistor dividers per converter, any output voltage between 800 mV and 6.0 V can be set. The center point of one divider is connected to the feedback pin, FB, and the center point of the other identical divider is connected to EAN. It is important to use 1% resistors. 10 kΩ, 1% is a good value for the lower leg resistors. In this case, the upper leg resistors for a given output voltage is determined by

$$R_{UPPER} = \frac{V_{OUT} - 0.8 \text{ V}}{0.08} (\text{k}\Omega) \quad (18)$$

Table 10 shows the resistor values for the most common output voltages.

Table 10. Typical Feedback Resistor Values

V _{out}	1.5 V	1.8 V	2.5 V
R _{UPPER}	9.1 kΩ	13 kΩ	22 kΩ
R _{LOWER}	10 kΩ	10 kΩ	10 kΩ

EFFICIENCY ENHANCEMENT

The efficiency of each switching regulator is inversely proportional to the losses during the switching conversion. The main factors to consider when attempting to maximize efficiency are

1. Resistive losses, which include the $R_{DS(ON)}$ of upper and lower MOSFETs, trace resistances, and output choke wire resistance.

These losses contribute a major part of the overall power loss in low voltage battery-powered applications. However, trying to reduce these resistive losses by using multiple MOSFETs and thick traces may lead to lower efficiency and higher price. This is due to the trade-off between reduced resistive loss and increased gate drive loss that must be considered when optimizing efficiency.

COMPENSATION LOOP DESIGN AND TEST METHOD

1. Choose the gain ($R2/R1$) for the desired bandwidth.
2. Place f_{z1} 20% to 30% below f_{LC} .
3. Place f_{z2} 20% to 30% above f_{LC} .
4. Place f_{p1} at f_{ESR} . Check the output capacitor for worst-case ESR tolerances.
5. Place f_{p2} at 40% to 60% of the oscillator frequency.
6. Estimate phase margins in full frequency range (zero frequency to zero gain crossing frequency).
7. Apply the designed compensation and test the transient response under a moderate step load change (30% to 60%) and various input voltages. Monitor the output voltage via an oscilloscope. The voltage overshoot or undershoot should be within 1% to 3% of the nominal output, without ringing and abnormal oscillation.

RECOMMENDED APPLICATIONS

1. ADP3025's switching channels are recommended to generate output current no greater than 5 A each. The maximum current output capability is subject to the limitation of ADP3025's gate driving capability and its maximum voltage rating.
2. For a system with input voltage up to 20 V, the ADP3025 can be used to generate 5 V/3.3 V system power rails at 200 kHz. Switching frequency of 300 kHz is not recommended because the worst-case on time of the top MOSFET is too narrow (~500 ns), leaving no room for current sensing.
3. For applications that use the silver box's 12 V rail as the input source, the ADP3025 can be configured to generate 5 V/3.3 V rails at both 200 kHz and 300 kHz.

LAYOUT CONSIDERATIONS

The following guidelines are recommended for optimal performance of a switching regulator in a portable PC system:

General Recommendations

1. For best results, a (minimum) 4-layer PCB is recommended. This should allow the needed versatility for control circuitry interconnections with optimal placement, a signal ground plane, power planes for both power ground and the input power, and wide interconnection traces in the rest of the power delivery current paths. Each square unit of 1 oz. copper trace has a resistance of ~0.53 m Ω at room temperature.
2. Whenever high currents must be routed between PCB layers, vias should be used liberally to create several parallel current paths so that the resistance and inductance introduced by these current paths is minimized and the via current rating is not exceeded.
3. The power and ground planes should overlap each other as little as possible. It is generally easiest (although not necessary) to have the power and signal ground planes on the same PCB layer. The planes should be connected nearest to the first input capacitor where the input ground current flows from the converter back to the battery.
4. If critical signal lines (including the voltage and current sense lines of the ADP3025) must cross through power circuitry, it is best if a signal ground plane can be interposed between those signal lines and the traces of the power circuitry. This serves as a shield to minimize noise injection into the signals at the expense of making signal ground a bit noisier.
5. The PGND1 and PGND2 pins of the ADP3025 should connect first to a ceramic bypass capacitor on the VIN pin and then to the power ground plane, using the shortest possible trace. However, the power ground plane should not extend under other signal components, including the ADP3025 itself. If necessary, follow the preceding guideline to use the signal plane as a shield between the power ground plane and the signal circuitry.
6. The AGND pin of the ADP3025 should connect first to the REF capacitor, and then to the signal ground plane. In cases where no signal ground plane can be used, short interconnections to other signal ground circuitry in the power converter should be used.
7. The output capacitors of the power converter should be connected to the signal ground plane even though power current flows in the ground of these capacitors. For this reason, it is advisable to avoid critical ground connections (e.g., the signal circuitry of the power converter) in the signal ground plane between the input and output capacitors. It is also advisable to keep the planar interconnection path short (i.e., have input and output capacitors close together).
8. The output capacitors should also be connected as close as possible to the load (or connector) that receives the power. If the load is distributed, the capacitors should also be distributed, generally in proportion to where the load tends to be more dynamic.
9. Absolutely avoid crossing any signal lines over the switching power path loop, described in the Power Circuitry section.

Power Circuitry

10. The switching power path should be routed on the PCB to encompass the smallest possible area in order to minimize radiated switching noise energy (i.e., EMI). Failure to take proper precautions often results in EMI problems for the entire PC system as well as noise-related operational problems in the power converter control circuitry. The switching power path is the loop formed by the current path through the input capacitors, the two FETs (and the power Schottky diode, if used), including all interconnecting PCB traces and planes. The use of short and wide interconnection traces is especially critical in this path for two reasons: it minimizes the inductance in the switching loop, which can cause high energy ringing, and it accommodates high current demand with minimal voltage loss.
11. A power Schottky diode (1 A ~ 2 A dc rating) placed from the lower FET's source (anode) to drain (cathode) helps to minimize switching power dissipation in the upper FET. In the absence of an effective Schottky diode, this dissipation occurs through the following sequence of switching events. The lower FET turns off in advance of the upper FET turning on (necessary to prevent cross-conduction). The circulating current in the power converter, no longer finding a path for current through the channel of the lower FET, draws current through the inherent body drain diode of the FET. The upper FET turns on, and the reverse recovery characteristic of the lower FET's body drain diode prevents the drain voltage from being pulled high quickly.

The upper FET then conducts very large current while it momentarily has a high voltage forced across it, which translates into added power dissipation in the upper FET. The Schottky diode minimizes this problem by carrying a majority of the circulating current when the lower FET is turned off, and by virtue of its essentially nonexistent reverse recovery time.

12. Whenever a power dissipating component (e.g., a power MOSFET) is soldered to a PCB, the liberal use of vias, both directly on the mounting pad and immediately surrounding it, is recommended. Two important reasons for this are: improved current rating through the vias (if it is a current path) and improved thermal performance, especially if the vias are extended to the opposite side of the PCB where a plane can more readily transfer the heat to the air.
13. The output power path, though not as critical as the switching power path, should also be routed to encompass a small area. The output power path is formed by the current path through the inductor, the output capacitors, and back to the input capacitors.
14. For best EMI containment, the power ground plane should extend fully under all the power components except the output capacitors. These are the input capacitors, the power MOSFETs and Schottky diode, the inductor, and any snubbing elements that might be added to dampen ringing. Avoid extending the power ground under any other circuitry or signal lines, including the voltage and current sense lines.

Signal Circuitry

15. The CS and SW traces should be Kelvin-connected to the upper MOSFET drain and source so that the additional voltage drop due to current flow on the PCB at the current sense comparator connections does not affect the sensed voltage. It is desirable to have the ADP3025 close to the output capacitor bank and not in the output power path so that any voltage drop between the output capacitors and the AGND pin is minimized and voltage regulation is not compromised.

OUTLINE DIMENSIONS

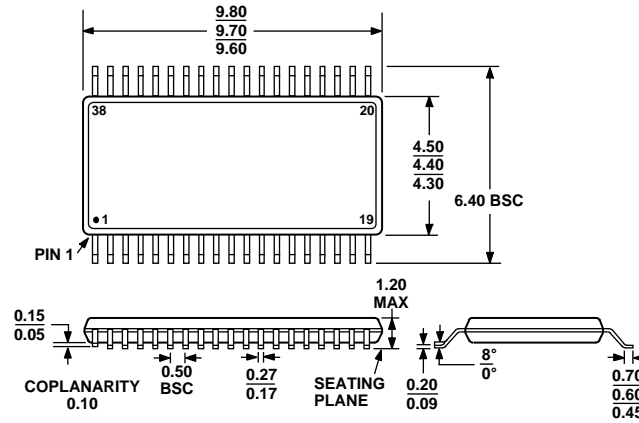

COMPLIANT TO JEDEC STANDARDS MO-153BD-1

Figure 19. 38-Lead Thin Shrink Small Outline Package [TSSOP] (RU-38)
Dimensions shown in millimeters

ORDERING GUIDE

Model	Temperature Range	Package Description	Package Option
ADP3025JRU-REEL	0°C to 70°C	Thin Shrink Small Outline (TSSOP)	RU-38

NOTES



NOTES



ADP3025

NOTES

EEPW 电子产品世界
.com.cn