

### FEATURES

- Complete single-chip JPEG 2000 compression and decompression solution for video and still images identical in pinout and footprint to the ADV202 and supports all the functionality of the ADV202**
- Power reduction of at least 30% compared with ADV202**
- JTAG/boundary scan support**
- Patented SURF<sup>®</sup> (spatial ultraefficient recursive filtering) technology enables low power, low cost wavelet-based compression**
- Supports both 9/7 and 5/3 wavelet transforms with up to 6 levels of transform**
- Video interface directly supporting ITU-R BT.656, SMPTE 125M PAL/NTSC, SMPTE 274M, SMPTE 293M (525p), and ITU-R BT.1358 (625p), or any video format with a maximum input rate of 65 MSPS for irreversible mode or 40 MSPS for reversible mode**
- Programmable tile/image size with widths up to 4096 pixels in single-component mode; maximum tile/image height: 4096 pixels**
- 2 or more ADV212s can be combined to support full-frame SMPTE 274M HDTV (1080i) or SMPTE 296M (720p)**
- Flexible, asynchronous SRAM-style host interface allows glueless connection to most 16-/32-bit microcontrollers and ASICs**
- 2.5 V or 3.3 V input/output and 1.5 V core supply**
- 12 mm × 12 mm, 121-ball CSPBGA with a speed grade of 115 MHz, or 13 mm × 13 mm, 144-ball CSPBGA with a speed grade of 150 MHz**

### APPLICATIONS

- Networked video and image distribution systems
- Wireless video and image distribution
- Image archival/retrieval
- Digital CCTV and surveillance systems
- Digital cinema systems
- Professional video editing and recording
- Digital still cameras
- Digital camcorders

### GENERAL DESCRIPTION

The ADV212 is a single-chip JPEG 2000 codec targeted for video and high bandwidth image compression applications that can benefit from the enhanced quality and features provided by the JPEG 2000 (J2K)—ISO/IEC15444-1 image compression standard. The part implements the computationally intensive operations of the JPEG 2000 image compression standard and provides fully compliant code-stream generation for most applications.

The dedicated video port of the ADV212 provides glueless connection to common digital video standards such as ITU-R BT.656, SMPTE 125M, SMPTE 293M (525p), ITU-R BT.1358 (625p), SMPTE 274M (1080i), or SMPTE 296M (720p). A variety of other high speed, synchronous pixel and video formats can also be supported by using the programmable framing and validation signals.

The ADV212 is an upgrade version of the ADV202 that is identical in pinout and footprint. It supports all the functionality of the ADV202 and has the following additional options:

- JTAG/boundary scan support
- Power reduction of at least 30% compared with the ADV202

### FUNCTIONAL BLOCK DIAGRAM

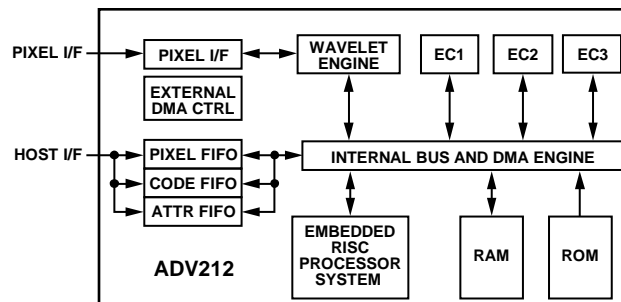

Figure 1.

#### Rev. 0

Information furnished by Analog Devices is believed to be accurate and reliable. However, no responsibility is assumed by Analog Devices for its use, nor for any infringements of patents or other rights of third parties that may result from its use. Specifications subject to change without notice. No license is granted by implication or otherwise under any patent or patent rights of Analog Devices. Trademarks and registered trademarks are the property of their respective owners.

# ADV212

## TABLE OF CONTENTS

Features .....	1	Memory System.....	25
Applications.....	1	Internal DMA Engine.....	25
General Description.....	1	ADV212 Interface.....	26
Revision History.....	2	Video Interface (VDATA Bus).....	26
JPEG 2000 Feature Support.....	3	Host Interface (HDATA Bus).....	26
Specifications.....	4	Direct and Indirect Registers.....	26
Supply Voltages and Current.....	4	Control Access Registers.....	27
Input/Output Specifications.....	4	Pin Configuration and Bus Sizes/Modes.....	27
Clock and RESET Specifications.....	5	Stage Register.....	27
Normal Host Mode—Write Operation.....	6	JDATA Mode.....	27
Normal Host Mode—Read Operation.....	7	External DMA Engine.....	27
DREQ/DACK DMA Mode—Single FIFO Write Operation..	8	Internal Registers.....	28
DREQ/DACK DMA Mode—Single FIFO Read Operation .	10	Direct Registers.....	28
External DMA Mode—FIFO Write, Burst Mode.....	12	Indirect Registers.....	29
External DMA Mode—FIFO Read, Burst Mode.....	13	PLL.....	30
Streaming Mode (JDATA)—FIFO Read/Write.....	14	Hardware Boot.....	31
VDATA Mode Timing.....	15	Video Input Formats.....	32
Raw Pixel Mode Timing.....	17	Applications.....	34
JTAG Timing.....	18	Encode—Multichip Mode.....	34
Absolute Maximum Ratings.....	19	Decode—Multichip Master/Slave.....	35
Thermal Resistance.....	19	Digital Still Camera/Camcorder.....	36
ESD Caution.....	19	Encode/Decode SDTV Video Application.....	37
Pin Configurations and Function Descriptions.....	20	32-Bit Host Application.....	38
Theory of Operation.....	25	HIPI (Host Interface—Pixel Interface).....	39
Wavelet Engine.....	25	JDATA Interface.....	40
Entropy Codecs.....	25	Outline Dimensions.....	41
Embedded Processor System.....	25	Ordering Guide.....	42

## REVISION HISTORY

10/06—Revision 0: Initial Version

The ADV212 can process images at a rate of 40 MSPS in reversible mode and at higher rates when used in irreversible mode. The ADV212 contains a dedicated wavelet transform engine, three entropy codecs, an on-board memory system, and an embedded reduced instruction set computer (RISC) processor that can provide a complete JPEG 2000 compression/decompression solution.

The wavelet processor supports the 9/7 irreversible wavelet transform and the 5/3 wavelet transform in reversible and irreversible modes. The entropy codecs support all features in the JPEG 2000 Part 1 specification, except maximum shift region of interest (ROI).

The ADV212 operates on a rectangular array of pixel samples called a tile. A tile can contain a complete image, up to the maximum supported size, or some portion of an image. The maximum horizontal tile size supported depends on the wavelet transform selected and the number of samples in the tile. Images larger than the ADV212's maximum tile size can be broken into individual tiles and then sent sequentially to the chip while maintaining a single, fully compliant JPEG 2000 code stream for the entire image.

## JPEG 2000 FEATURE SUPPORT

The ADV212 supports a broad set of features that are included in Part 1 of the JPEG 2000 standard (ISO/IEC 15444). See [ADV212 User's Guide](#) for information on the JPEG 2000 features that the ADV212 currently supports.

Depending on the particular application requirements, the ADV212 can provide varying levels of JPEG 2000 compression support. It can provide raw code block and attribute data output, which allows the host software to have complete control over the generation of the JPEG 2000 code stream and other aspects of the compression process such as bit-rate control. Otherwise, the ADV212 can create a complete, fully compliant JPEG 2000 code stream (J2C) and enhanced file formats such as JP2.

EEPW 电子产品世界  
.com.cn

# ADV212

## SPECIFICATIONS

Specifications apply to IOVDD = 2.5 V or 3.3 V over operating temperature range, unless otherwise specified.

### SUPPLY VOLTAGES AND CURRENT

Table 1.

Parameter	Mnemonic	Min	Typ	Max	Unit
DC Supply Voltage, Core	VDD	1.425	1.5	1.575	V
DC Supply Voltage, Input/Output	IOVDD	2.375	2.5	2.625	V
DC Supply Voltage, Input/Output	IOVDD	3.135	3.3	3.465	V
Input Range	V <sub>IN</sub>	-0.3		V <sub>DDI/O</sub> + 0.3	V
Operating Ambient Temperature Range in Free Air	T	-40	+25	+85	°C
Static Current <sup>1</sup>	I <sub>DD</sub>		15	30	mA
Dynamic Current, Core (JCLK Frequency = 150 MHz) <sup>2</sup>			380	440	mA
Dynamic Current, Core (JCLK Frequency = 108 MHz)			280	320	mA
Dynamic Current, Core (JCLK Frequency = 81 MHz)			210	290	mA
Dynamic Current, Input/Output			40	50	mA

<sup>1</sup> No clock or input/output activity.

<sup>2</sup> ADV212-150 only.

### INPUT/OUTPUT SPECIFICATIONS

Table 2.

Parameter	Mnemonic	Min	Typ	Max	Unit	Test Conditions
High Level Input Voltage	V <sub>IH</sub> (3.3 V)	2.2			V	VDD = maximum
High Level Input Voltage	V <sub>IH</sub> (2.5 V)	1.9			V	VDD = maximum
Low Level Input Voltage	V <sub>IL</sub> (3.3 V, 2.5 V)			0.6	V	VDD = minimum
High Level Output Voltage	V <sub>OH</sub> (3.3 V)	2.4			V	VDD = minimum, I <sub>OH</sub> = -0.5 mA
High Level Output Voltage	V <sub>OH</sub> (2.5 V)	2.0			V	VDD = minimum, I <sub>OH</sub> = -0.5 mA
Low Level Output Voltage	V <sub>OL</sub> (3.3 V, 2.5 V)			0.4	V	VDD = minimum, I <sub>OL</sub> = +2 mA
High Level Input Current	I <sub>IH</sub>			1.0	μA	VDD = maximum, V <sub>IN</sub> = VDD
Low Level Input Current	I <sub>IL</sub>			1.0	μA	VDD = maximum, V <sub>IN</sub> = 0 V
High Level Three-State Leakage Current	I <sub>OZH</sub>			1.0	μA	VDD = maximum, V <sub>IN</sub> = VDD
Low Level Three-State Leakage Current	I <sub>OZL</sub>			1.0	μA	VDD = maximum, V <sub>IN</sub> = 0 V
Input Pin Capacitance	C <sub>I</sub>			8	pF	
Output Pin Capacitance	C <sub>O</sub>			8	pF	

**CLOCK AND RESET SPECIFICATIONS**

Table 3.

Parameter	Mnemonic	Min	Typ	Max	Unit
MCLK Period	$t_{MCLK}$	13.3		100	ns
MCLK Frequency	$f_{MCLK}$	10		75.18	MHz
MCLK Width Low	$t_{MCLKL}$	6			ns
MCLK Width High	$t_{MCLKH}$	6			ns
VCLK Period	$t_{VCLK}$	13.4		50	ns
VCLK Frequency	$f_{VCLK}$	20		74.60	MHz
VCLK Width Low	$t_{VCLKL}$	5			ns
VCLK Width High	$t_{VCLKH}$	5			ns
RESET Width Low	$t_{RESET}$	5			MCLK cycles <sup>1</sup>

<sup>1</sup> For a definition of MCLK, see Figure 32.

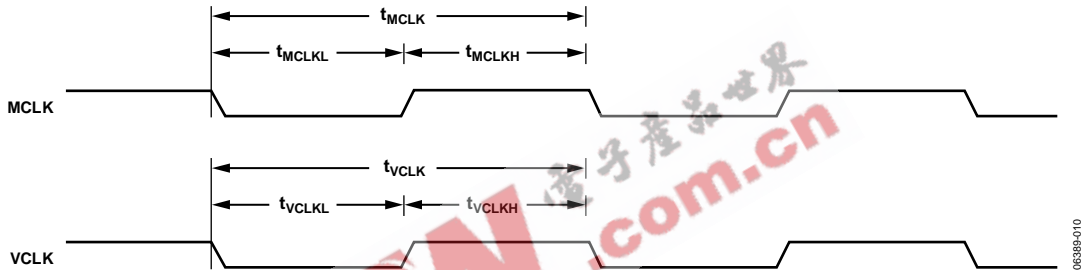

Figure 2. Input Clock

06388010

# ADV212

## NORMAL HOST MODE—WRITE OPERATION

Table 4.

Parameter	Mnemonic	Min	Typ	Max	Unit
$\overline{WE}$ to $\overline{ACK}$ , Direct Registers and FIFO Accesses	$t_{\overline{ACK}}$ (direct)	5		$1.5 \times JCLK + 7.0$	ns
$\overline{WE}$ to $\overline{ACK}$ , Indirect Registers	$t_{\overline{ACK}}$ (indirect)	5		$2.5 \times JCLK + 7.0$	ns
Data Setup	$t_{SD}$	3.0			ns
Data Hold	$t_{HD}$	1.5			ns
Address Setup	$t_{SA}$	2			ns
Address Hold	$t_{HA}$	2			ns
$\overline{CS}$ to $\overline{WE}$ Setup	$t_{SC}$	0			ns
$\overline{CS}$ Hold	$t_{HC}$	0			ns
Write Inactive Pulse Width (Minimum Time Until Next $\overline{WE}$ Pulse)	$t_{WH}$	$2.5 JCLK^1$			ns
Write Active Pulse Width	$t_{WL}$	$2.5 JCLK$			ns
Write Cycle Time	$t_{WCYC}$	$5 JCLK$			ns

<sup>1</sup> For a definition of JCLK, see Figure 32.

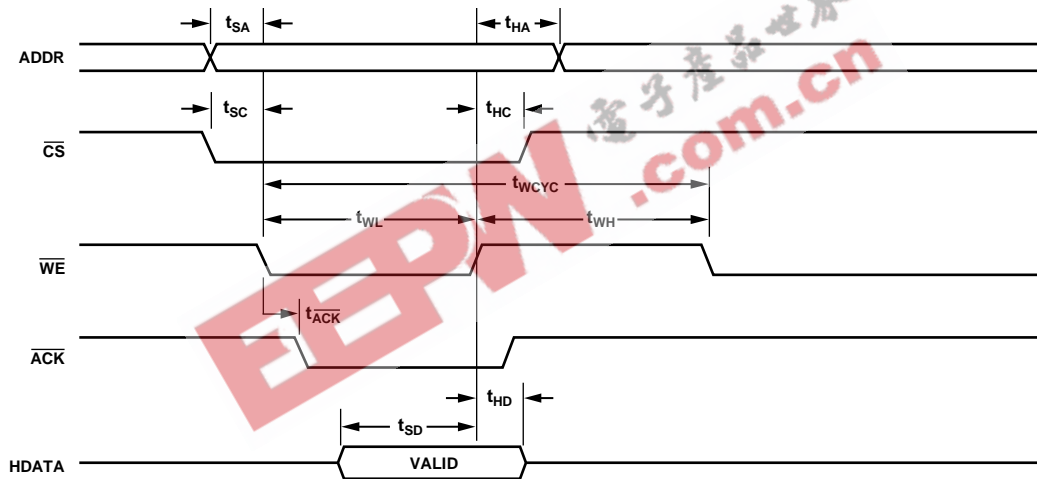

Figure 3. Normal Host Mode—Write Operation

**NORMAL HOST MODE—READ OPERATION**

**Table 5.**

Parameter	Mnemonic	Min	Typ	Max	Unit
$\overline{RD}$ to $\overline{ACK}$ , Direct Registers and FIFO Accesses	$t_{\overline{ACK}}^{\text{(direct)}}$ <sup>1</sup>	5		$1.5 \times \text{JCLK} + 7.0$	ns
$\overline{RD}$ to $\overline{ACK}$ , Indirect Registers	$t_{\overline{ACK}}^{\text{(indirect)}}$ <sup>1</sup>	$10.5 \times \text{JCLK}$		$15.5 \times \text{JCLK} + 7.0$	ns
Read Access Time, Direct Registers	$t_{\text{DRD}}^{\text{(direct)}}$	5		$1.5 \times \text{JCLK} + 7.0$	ns
Read Access Time, Indirect Registers	$t_{\text{DRD}}^{\text{(indirect)}}$	$10.5 \times \text{JCLK}$		$15.5 \times \text{JCLK} + 7.0$	ns
Data Hold	$t_{\text{HZRD}}$	2		8.5	ns
$\overline{CS}$ to $\overline{RD}$ Setup	$t_{\text{SC}}$	0			ns
Address Setup	$t_{\text{SA}}$	2			ns
$\overline{CS}$ Hold	$t_{\text{HC}}$	0			ns
Address Hold	$t_{\text{HA}}$	2			ns
Read Inactive Pulse Width	$t_{\text{RH}}$	$2.5 \text{ JCLK}^2$			ns
Read Active Pulse Width	$t_{\text{RL}}$	$2.5 \text{ JCLK}$			ns
Read Cycle Time, Direct Registers	$t_{\text{RCYC}}$	$5.0 \text{ JCLK}$			ns

<sup>1</sup> Timing relationship between  $\overline{ACK}$  falling transition and HDATA valid is not guaranteed. HDATA valid hold time is guaranteed with respect to  $\overline{RD}$  rising transition. A minimum of three JCLK cycles is recommended between  $\overline{ACK}$  assert and  $\overline{RD}$  deassert.

<sup>2</sup> For a definition of JCLK, see Figure 32.

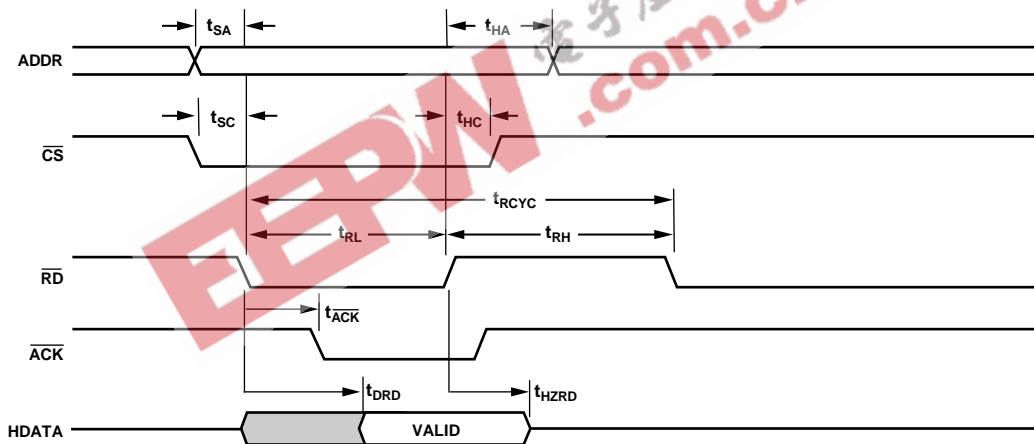

Figure 4. Normal Host Mode—Read Operation

06389-011

# ADV212

## DREQ/DACK DMA MODE—SINGLE FIFO WRITE OPERATION

Table 6.

Parameter	Mnemonic	Min	Typ	Max	Unit
DREQ Pulse Width	$\overline{\text{DREQ}}_{\text{PULSE}}$	1 JCLK <sup>1</sup>		15 JCLK	ns
DACK Assert to Subsequent DREQ Delay	$t_{\overline{\text{DREQ}}}$	2.5 JCLK		$3.5 \times \text{JCLK} + 8.5$	ns
WE to DACK Setup	$t_{\overline{\text{WE}}_{\text{SU}}}$	0			ns
Data to DACK Deassert Setup	$t_{\text{SU}}$	2			ns
Data to DACK Deassert Hold	$t_{\text{HD}}$	2			ns
DACK Assert Pulse Width	$\overline{\text{DACK}}_{\text{LO}}$	2 JCLK			ns
DACK Deassert Pulse Width	$\overline{\text{DACK}}_{\text{HI}}$	2 JCLK			ns
WE Hold After DACK Deassert	$t_{\overline{\text{WE}}_{\text{HD}}}$	0			ns
WE Assert to FSRQ Deassert (FIFO Full)	$\overline{\text{WFSRQ}}$	1.5 JCLK		$2.5 \times \text{JCLK} + 7.5$	ns
DACK to DREQ Deassert ( $\text{DR} \times \text{PULS} = 0$ )	$t_{\overline{\text{DREQ}}_{\text{RTN}}}$	2.5 JCLK		$3.5 \times \text{JCLK} + 9.0$	ns

<sup>1</sup> For a definition of JCLK, see Figure 32.

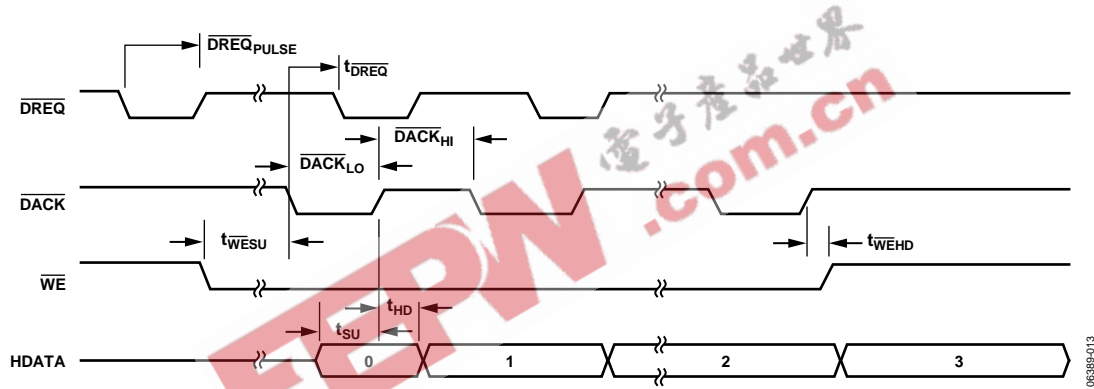

Figure 5. Single Write for DREQ/DACK DMA Mode for Assigned DMA Channel (EDMOD0/EDMOD1 <14:11> Not Programmed to a Value of 0000)

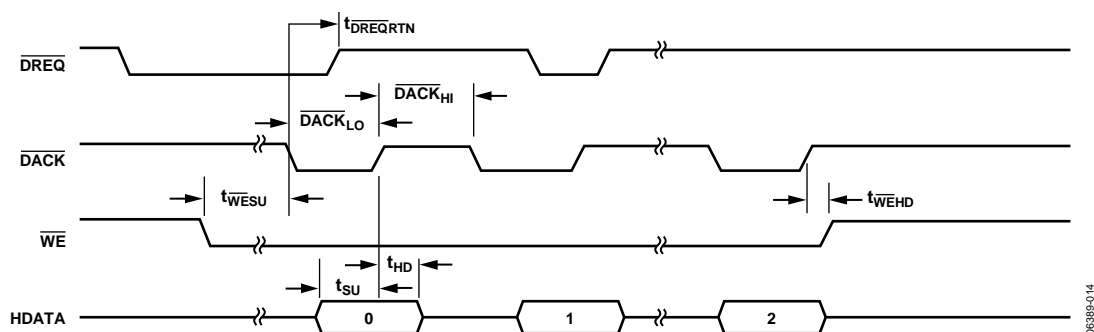

Figure 6. Single Write for DREQ/DACK DMA Mode for Assigned DMA Channel (EDMOD0/EDMOD1 <14:11> Programmed to a Value of 0000)



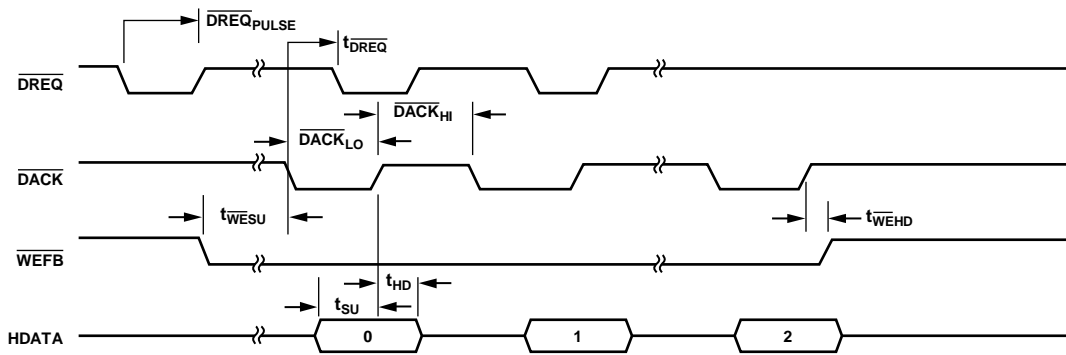

Figure 7. Single Write Cycle for Fly-By DMA Mode (DREQ Pulse Width Is Programmable)

063989-015

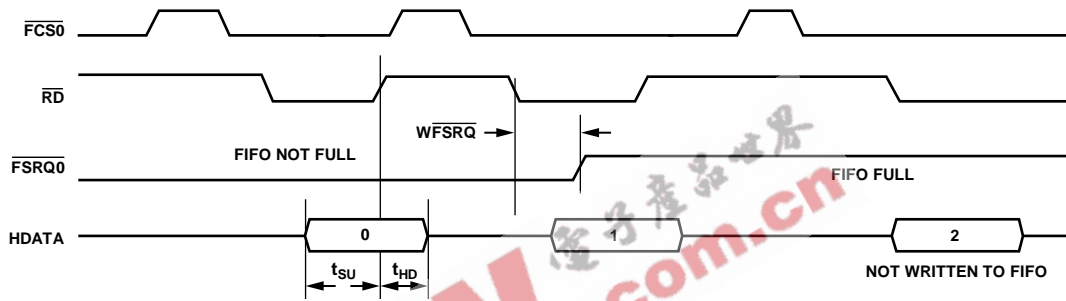

Figure 8. Single Write Access for DCS DMA Mode

063989-021

# ADV212

## DREQ/DACK DMA MODE—SINGLE FIFO READ OPERATION

Table 7.

Parameter	Mnemonic	Min	Typ	Max	Unit
DREQ Pulse Width	DREQ <sub>PULSE</sub>	1 JCLK <sup>1</sup>		15 JCLK	ns
DACK Assert to Subsequent DREQ Delay	t <sub>DREQ</sub>	2.5 JCLK		3.5 × JCLK + 9.0	ns
RD to DACK Setup	t <sub>RD<sub>SU</sub></sub>	0			ns
DACK to Data Valid	t <sub>RD</sub>	2.5		11	ns
Data Hold	t <sub>HD</sub>	1.5			ns
DACK Assert Pulse Width	DACK <sub>LO</sub>	2 JCLK			ns
DACK Deassert Pulse Width	DACK <sub>HI</sub>	2 JCLK			ns
RD Hold after DACK Deassert	t <sub>RD<sub>HD</sub></sub>	0			ns
RD Assert to FSRQ Deassert (FIFO Empty)	RDFSQ	1.5 JCLK		2.5 × JCLK + 9.0	ns
DACK to DREQ Deassert (DR × PULS = 0)	t <sub>DREQ<sub>RTN</sub></sub>	2.5 JCLK		3.5 × JCLK + 9.0	ns

<sup>1</sup> For a definition of JCLK, see Figure 32.

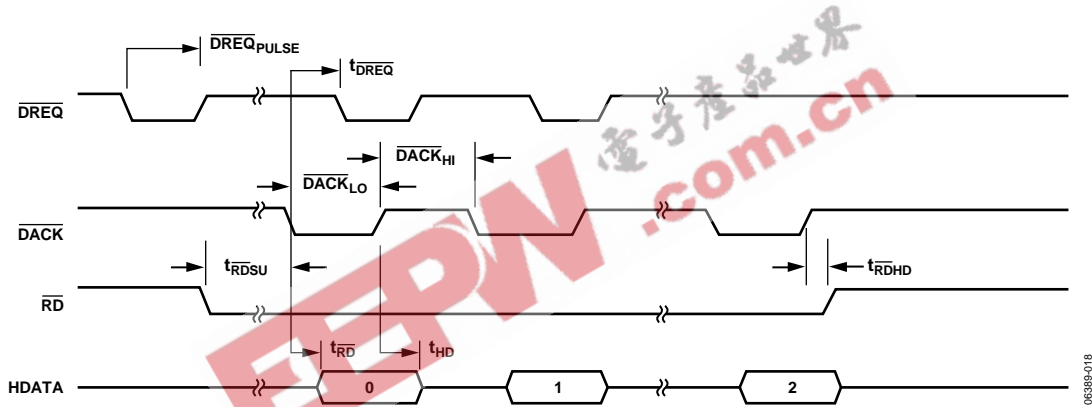

Figure 9. Single Read for DREQ/DACK DMA Mode for Assigned DMA Channel (EDMOD0/EDMOD1 <14:11> Not Programmed to a Value of 0000)

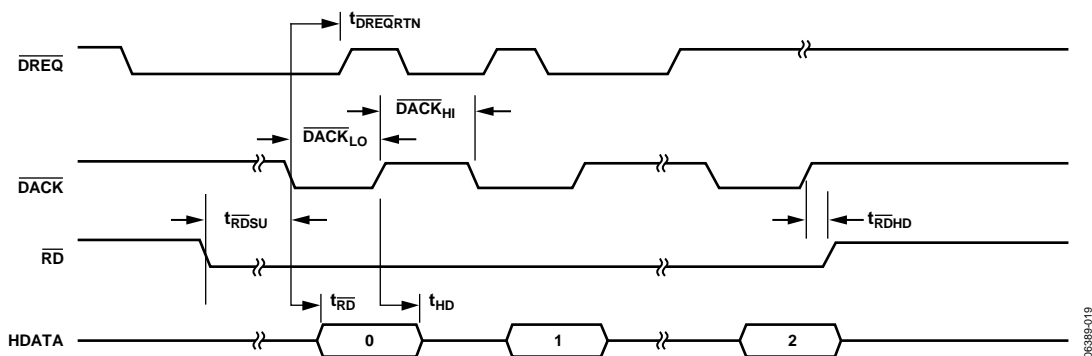

Figure 10. Single Read for DREQ/DACK DMA Mode for Assigned DMA Channel (EDMOD0/EDMOD1 <14:11> Programmed to a Value of 0000)

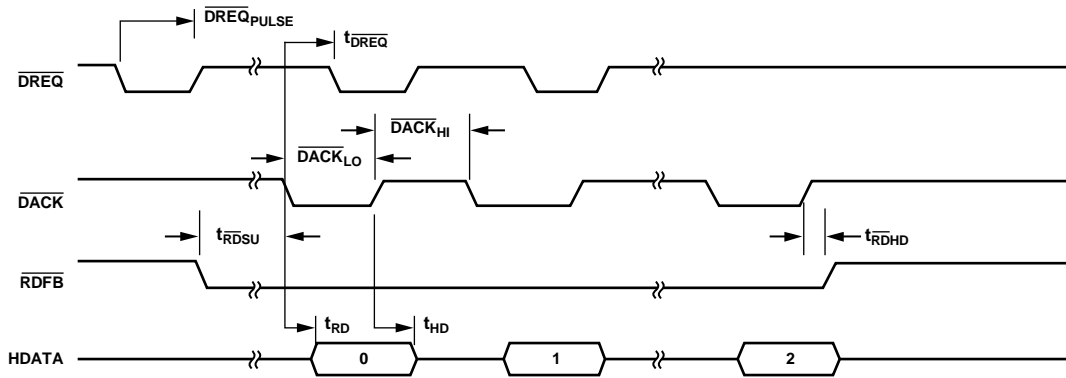

Figure 11. Single Read Cycle for Fly-By DMA Mode  
(DREQ Pulse Width Is Programmable)

06389-020

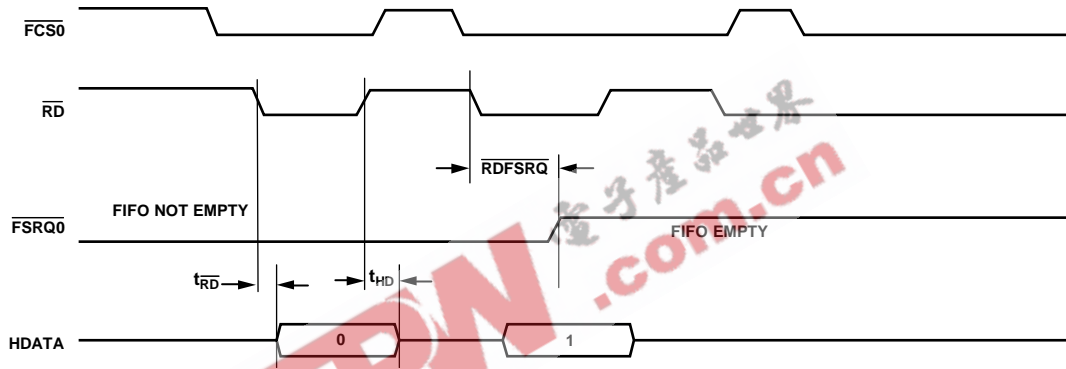

Figure 12. Single Read Access for DCS DMA Mode

06389-090

# ADV212

## EXTERNAL DMA MODE—FIFO WRITE, BURST MODE

Table 8.

Parameter	Mnemonic	Min	Typ	Max	Unit
DREQ Pulse Width <sup>1</sup>	$\overline{\text{DREQ}}_{\text{PULSE}}$	1 JCLK <sup>2</sup>		15 JCLK	ns
$\overline{\text{WE}}$ to $\overline{\text{DREQ}}$ Deassert ( $\text{DR} \times \text{PULS} = 0$ )	$t_{\overline{\text{DREQRTN}}}$	2.5 JCLK		$3.5 \times \text{JCLK} + 7.5$	ns
$\overline{\text{DACK}}$ to $\overline{\text{WE}}$ Setup	$t_{\overline{\text{DACKSU}}}$	0			ns
Data Setup	$t_{\text{SU}}$	2.5			ns
Data Hold	$t_{\text{HD}}$	2			ns
$\overline{\text{WE}}$ Assert Pulse Width	$\overline{\text{WE}}_{\text{LO}}$	1.5 JCLK			ns
$\overline{\text{WE}}$ Deassert Pulse Width	$\overline{\text{WE}}_{\text{HI}}$	1.5 JCLK			ns
$\overline{\text{WE}}$ Deassert to Next $\overline{\text{DREQ}}$	$t_{\overline{\text{DREQWAIT}}}$	2.5 JCLK		$4.5 \times \text{JCLK} + 9.0$	ns
$\overline{\text{WE}}$ Deassert to $\overline{\text{DACK}}$ Deassert	$t_{\overline{\text{WE\_DACK}}}$	0			ns

<sup>1</sup> Applies to assigned DMA channel, if EDMOD0 or EDMOD1 <14:11> is programmed to a nonzero value.

<sup>2</sup> For a definition of JCLK, see Figure 32.

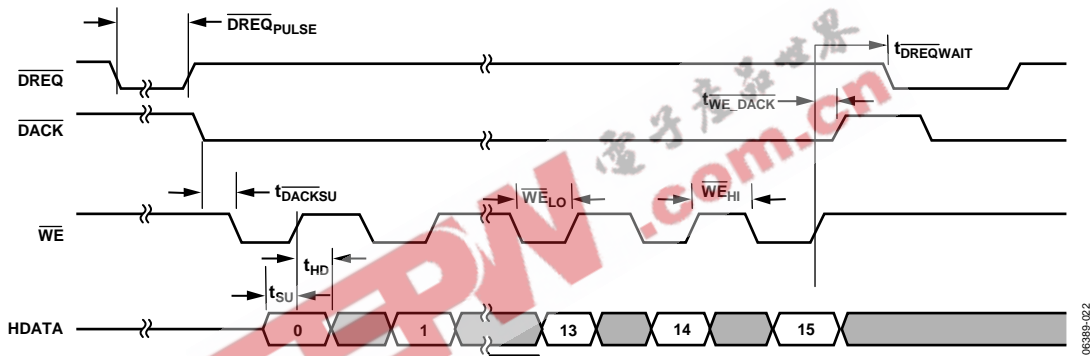

Figure 13. Burst Write Cycle for DREQ/DMA Mode for Assigned DMA Channel (EDMOD0/EDMOD1 <14:11> Not Programmed to a Value of 0000)

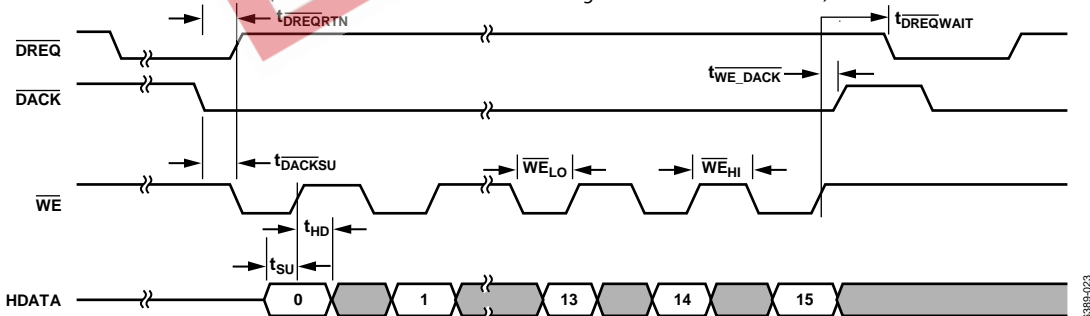

Figure 14. Burst Write Cycle for DREQ/DMA Mode for Assigned DMA Channel (EDMOD0/EDMOD1 <14:11> Programmed to a Value of 0000)

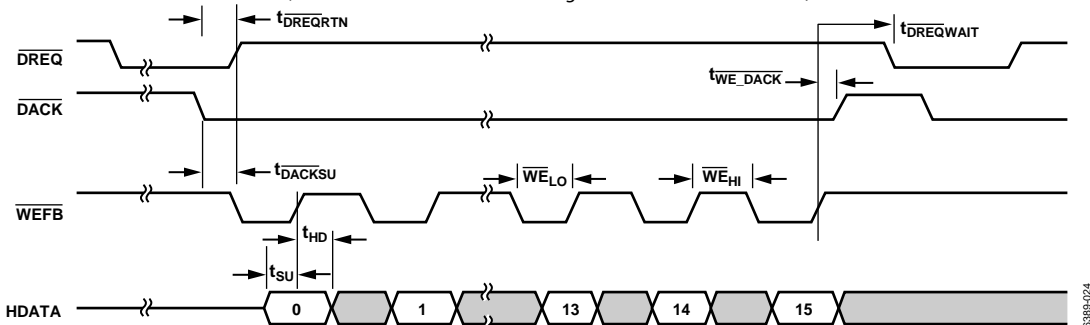

Figure 15. Burst Write Cycle for Fly-By DMA Mode

**EXTERNAL DMA MODE—FIFO READ, BURST MODE**

**Table 9.**

Parameter	Mnemonic	Min	Typ	Max	Unit
DREQ Pulse Width <sup>1</sup>	DREQ <sub>PULSE</sub>	1 JCLK <sup>2</sup>		15 JCLK	ns
RD to DREQ Deassert (DR × PULS = 0)	t <sub>DREQRTN</sub>	2.5 JCLK		3.5 × JCLK + 7.5	ns
DACK to RD Setup	t <sub>DACKSU</sub>	0			ns
RD to Data Valid	t <sub>RD</sub>	2.5		9.7	ns
Data Hold	t <sub>HD</sub>	2.5			ns
RD Assert Pulse Width	RD <sub>LO</sub>	1.5 JCLK			ns
RD Deassert Pulse Width	RD <sub>HI</sub>	1.5 JCLK			ns
RD Deassert to Next DREQ	t <sub>DREQWAIT</sub>	2.5 JCLK		3.5 × JCLK + 7.5	ns
RD Deassert to DACK Deassert	t <sub>RD_DACK</sub>	0			ns

<sup>1</sup> Applies to assigned DMA channel if EDMOD0 or EDMOD1 <14:11> is programmed to a nonzero value.

<sup>2</sup> For a definition of JCLK, see Figure 32.

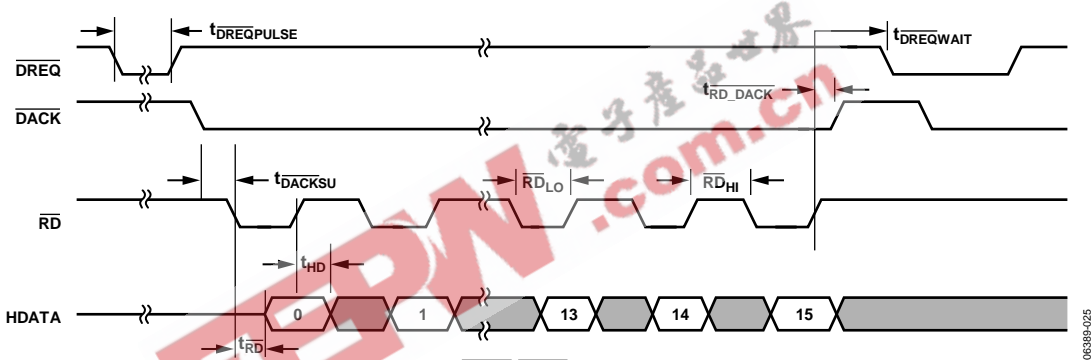

Figure 16. Burst Read Cycle for DREQ/DACK DMA Mode for Assigned DMA Channel (EMOD0/EDMOD1 <14:11> Not Programmed to a Value of 0)

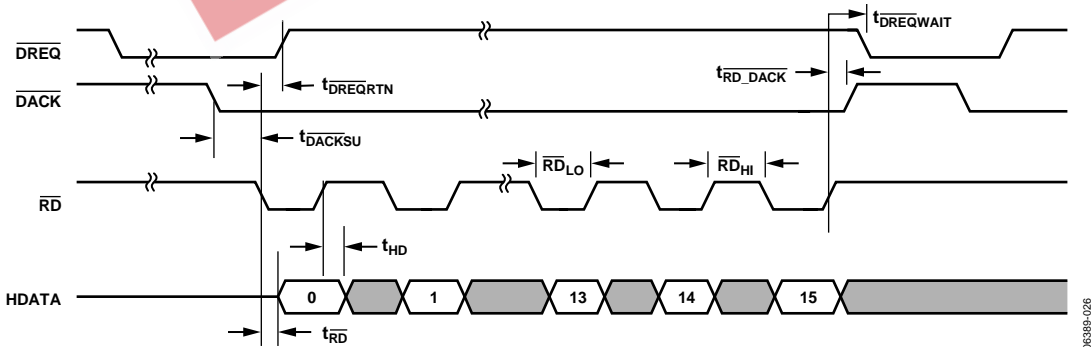

Figure 17. Burst Read Cycle for DREQ/DACK DMA Mode for Assigned DMA Channel (EMOD0/EDMOD1 <14:11> Programmed to a Value of 0000)

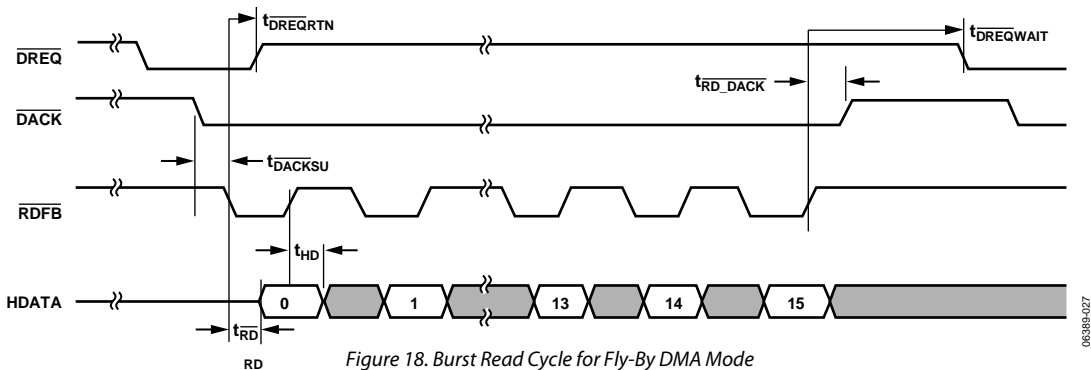

Figure 18. Burst Read Cycle for Fly-By DMA Mode

# ADV212

## STREAMING MODE (JDATA)—FIFO READ/WRITE

Table 10.

Parameter	Mnemonic	Min	Typ	Max	Unit
MCLK to JDATA Valid	JDATA <sub>TD</sub>	1.5 JCLK <sup>1</sup>		2.5 × JCLK + 9.5	ns
MCLK to VALID Assert/Deassert	VALID <sub>TD</sub>	1.5 JCLK		2.5 × JCLK + 8.0	ns
HOLD Setup to Rising MCLK	HOLD <sub>SU</sub>	3			ns
HOLD Hold from Rising MCLK	HOLD <sub>HD</sub>	3			ns
JDATA Setup to Rising MCLK	JDATA <sub>SU</sub>	3			ns
JDATA Hold from Rising MCLK	JDATA <sub>HD</sub>	3			ns

<sup>1</sup> For a definition of JCLK, see Figure 32.

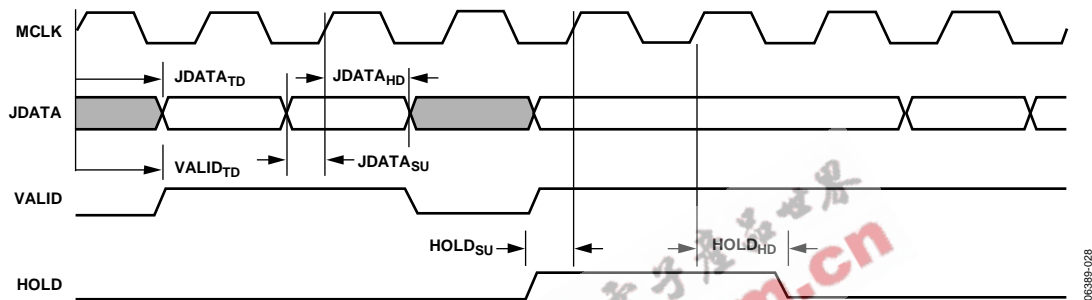

Figure 19. Streaming Mode Timing—Encode Mode JDATA Output

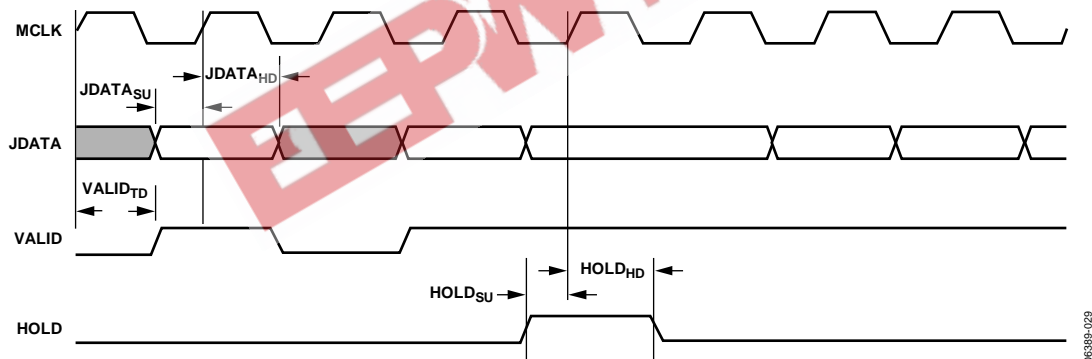

Figure 20. Streaming Mode Timing—Decode Mode JDATA Input

**VDATA MODE TIMING**

**Table 11.**

Parameter	Mnemonic	Min	Typ	Max	Unit
VCLK to VDATA Valid Delay (VDATA Output)	VDATA <sub>TD</sub>			12	ns
VDATA Setup to Rising VCLK (VDATA Input)	VDATA <sub>SU</sub>	4			ns
VDATA Hold from Rising VCLK (VDATA Input)	VDATA <sub>HD</sub>	4			ns
HSYNC Setup to Rising VCLK	HSYNC <sub>SU</sub>	3			ns
HSYNC Hold from Rising VCLK	HSYNC <sub>HD</sub>	4			ns
VCLK to HSYNC Valid Delay	HSYNC <sub>TD</sub>			12	ns
VSYNC Setup to Rising VCLK	VSYNC <sub>SU</sub>	3			ns
VSYNC Hold from Rising VCLK	VSYNC <sub>HD</sub>	4			ns
VCLK to VSYNC Valid Delay	VSYNC <sub>TD</sub>			12	ns
FIELD Setup to Rising VCLK	FIELD <sub>SU</sub>	4			ns
FIELD Hold from Rising VCLK	FIELD <sub>HD</sub>	3			ns
VCLK to FIELD Valid	FIELD <sub>TD</sub>			12	ns
Decode Slave Data Sync Delay (HSYNC Low to First 0xFF of EAV/SAV Code)	SYNC DELAY		8 <sup>1</sup>		VCLK cycles
Decode Slave Data Sync Delay (HSYNC Low to First Data for HVF Mode)			10 <sup>1</sup>		VCLK cycles

<sup>1</sup> The sync delay value varies according to the application. Refer to the [ADV212 User Guide](#) for more information.



Figure 21. Encode Video Mode Timing—CCIR 656 Mode

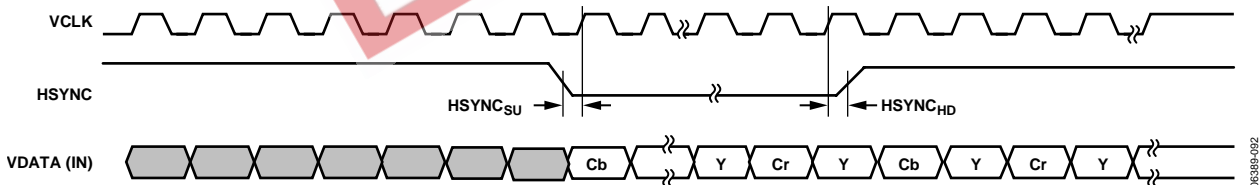

Figure 22. Encode Video Mode Timing—HVF Mode (HSYNC Timing)  
(HSYNC Programmed for Negative Polarity)

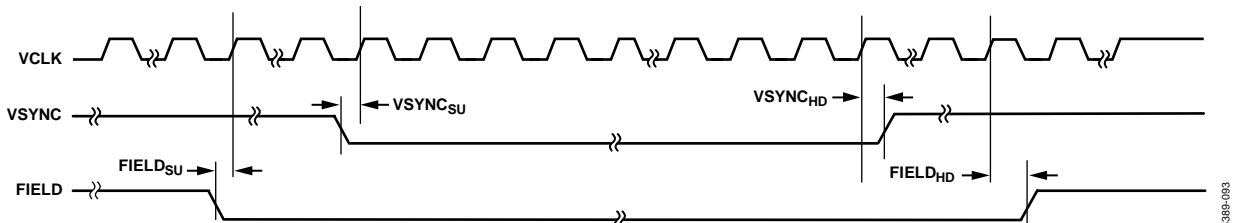

Figure 23. Encode Video Mode Timing—HVF Mode (VSYNC and FIELD Timing)  
(VSYNC and FIELD Programmed for Negative Polarity)

# ADV212

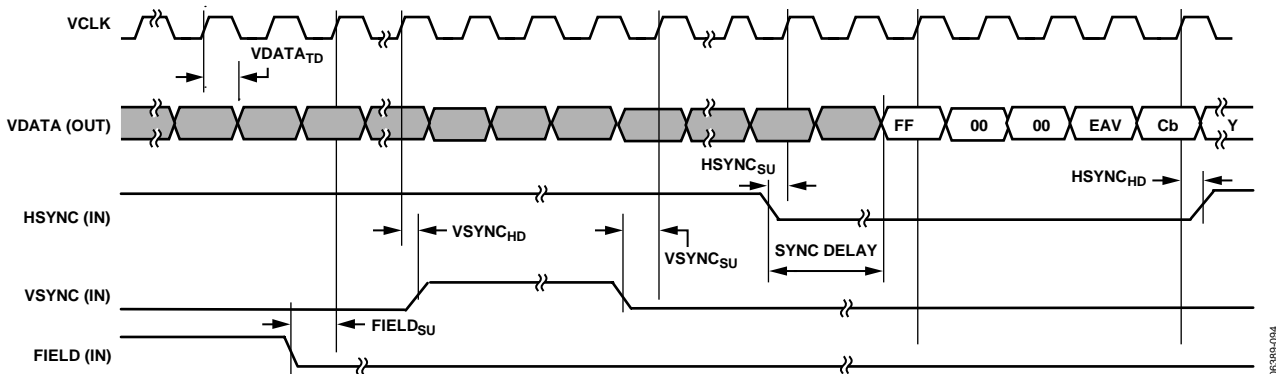

Figure 24. Decode Video Mode Timing—CCIR 656 Mode, Decode Slave (HSYNC, VSYNC, and FIELD Programmed to Negative Polarity)

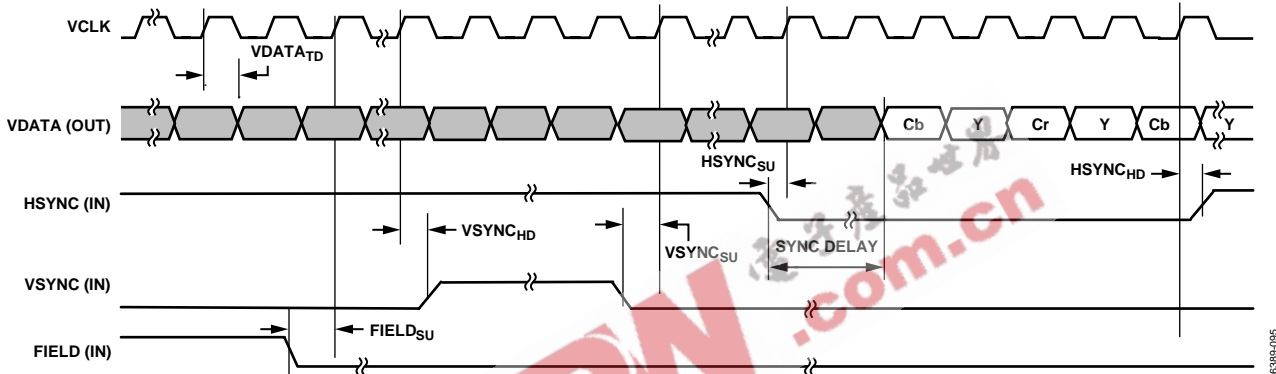

Figure 25. Decode Video Mode Timing—HVF Mode, Decode Slave (HSYNC, VSYNC, and FIELD Programmed to Negative Polarity)

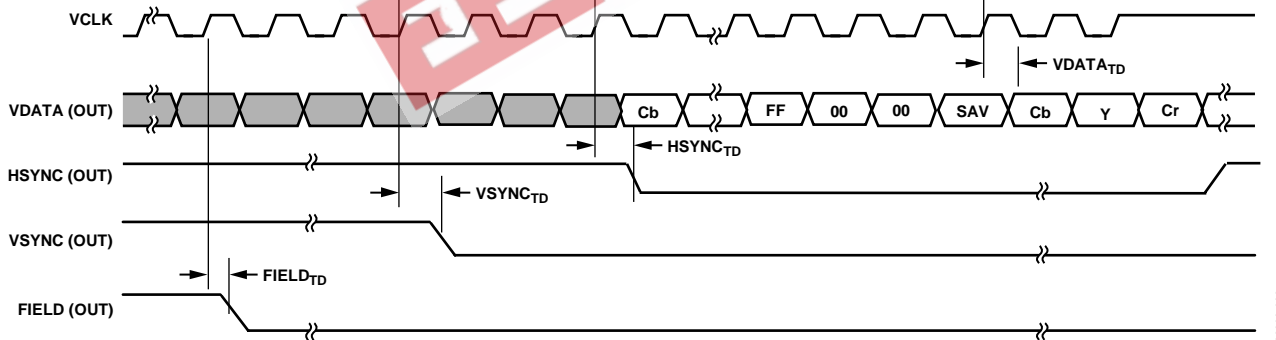

Figure 26. Decode Video Mode Timing—CCIR 656 Mode, Decode Master (HSYNC, VSYNC, and FIELD Programmed to Negative Polarity)

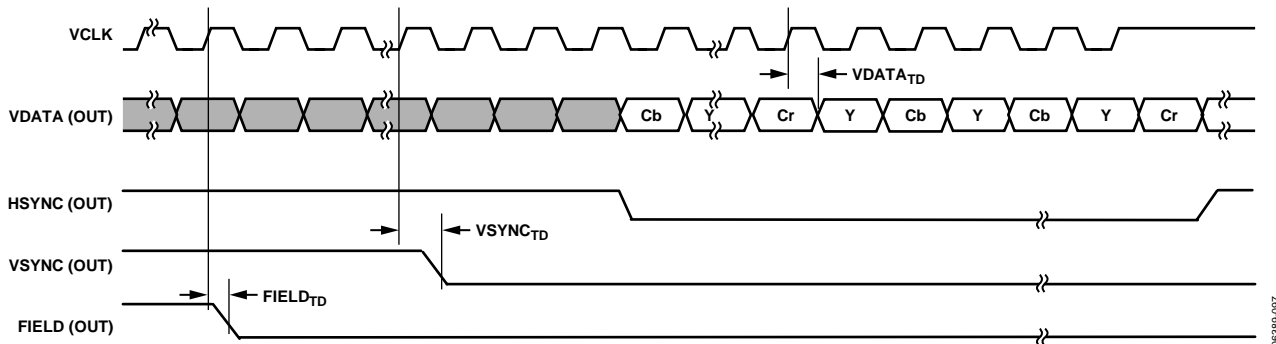

Figure 27. Decode Video Mode Timing—HVF Mode, Decode Master (HSYNC, VSYNC, and FIELD Programmed to Negative Polarity)



**RAW PIXEL MODE TIMING**

Table 12.

Parameter	Mnemonic	Min	Typ	Max	Unit
VCLK to PIXELDATA Valid Delay (PIXELDATA Output)	VDATA <sub>TD</sub>			12	ns
PIXELDATA Setup to Rising VCLK (PIXELDATA Input)	VDATA <sub>SU</sub>	4			ns
PIXELDATA Hold from Rising VCLK (PIXELDATA Input)	VDATA <sub>HD</sub>	4			ns
VCLK to VRDY Valid Delay	VRDY <sub>TD</sub>			12	ns
VFRM Setup to Rising VCLK (VFRAME Input)	VFRM <sub>SU</sub>	3			ns
VFRM Hold from Rising VCLK (VFRAME Input)	VFRM <sub>HD</sub>	4			ns
VCLK to VFRM Valid Delay (VFRAME Output)	VFRM <sub>TD</sub>			12	ns
VSTRB Setup to Rising VCLK	VSTRB <sub>SU</sub>	4			ns
VSTRB Hold from Rising VCLK	VSTRB <sub>HD</sub>	3			ns

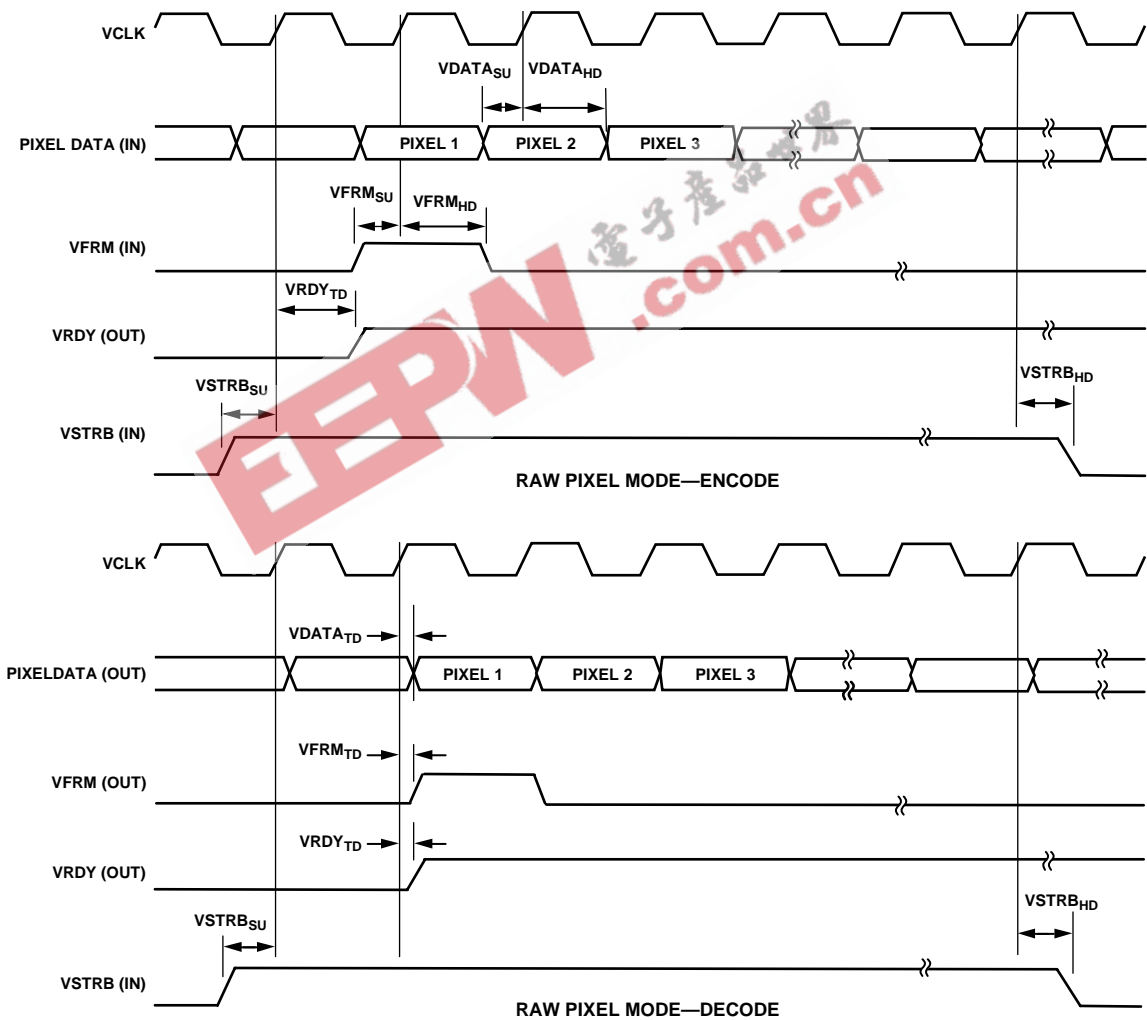

Figure 28. Raw Pixel Modes

06386-031

# ADV212

## JTAG TIMING

Table 13.

Parameter	Mnemonic	Min	Typ	Max	Unit
TCK Period	TCK	134			ns
TDI or TMS Setup Time	TDI <sub>SU</sub>	4.0			ns
TDI or TMS Hold Time	TDI <sub>HD</sub>	4.0			ns
TDO Hold Time	TDO <sub>HD</sub>	0.0			ns
TDO Valid	TDO <sub>VALID</sub>			10.0	ns
TRST Hold Time	TRST <sub>HD</sub>	4.0			ns
TRST Setup Time	TRST <sub>SU</sub>	4.0			ns
TRST Pulse Width Low	TRST <sub>LO</sub>	4			TCK cycles

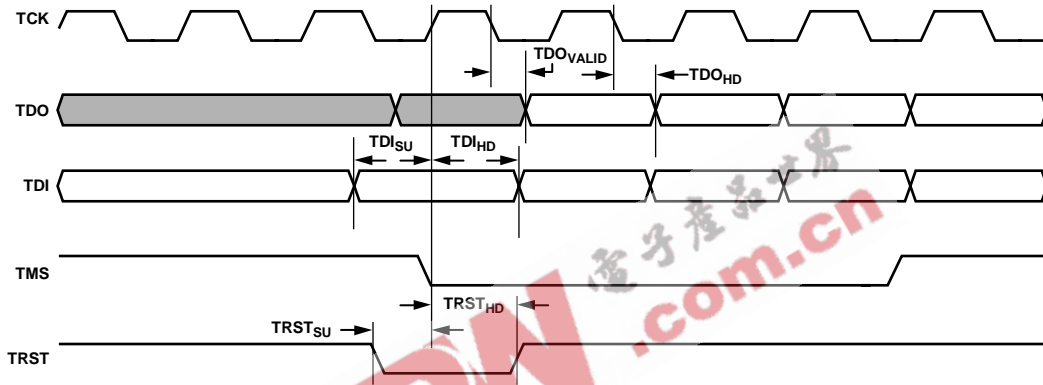

Figure 29. JTAG Timing

06389-032

## ABSOLUTE MAXIMUM RATINGS

Table 14.

Parameter	Rating
VDD – Supply Voltage, Core	–0.3 V to +1.65 V
IOVDD – Supply Voltage, Input/Output	–0.3 V to 3.63 V
Storage Temperature [T <sub>S</sub> ]	–65°C to +150°C
Reflow Soldering	
Pb-Free, 121-Ball	260°C [20 sec to 40 sec]
Pb-Free, 144-Ball	260°C [20 sec to 40 sec]

Stresses above those listed under Absolute Maximum Ratings may cause permanent damage to the device. This is a stress rating only; functional operation of the device at these or any other conditions above those indicated in the operational section of this specification is not implied. Exposure to absolute maximum rating conditions for extended periods may affect device reliability.

## THERMAL RESISTANCE

$\theta_{JA}$  is specified for the worst-case conditions, that is, a device soldered in a circuit board for surface-mount packages.

Table 15. Thermal Resistance

Package Type	$\theta_{JA}$	$\theta_{JC}$	Unit
144-Ball ADV212BBCZ	22.5	3.8	°C/W
121-Ball ADV212BBCZ	32.8	7.92	°C/W

## ESD CAUTION



**ESD (electrostatic discharge) sensitive device.** Charged devices and circuit boards can discharge without detection. Although this product features patented or proprietary protection circuitry, damage may occur on devices subjected to high energy ESD. Therefore, proper ESD precautions should be taken to avoid performance degradation or loss of functionality.

EEPW.com.cn 电子产品世界

# ADV212

## PIN CONFIGURATIONS AND FUNCTION DESCRIPTIONS

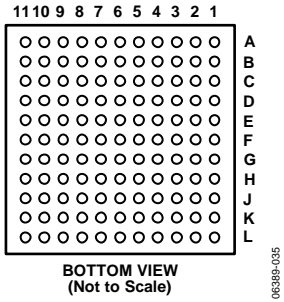

Figure 30.121-Ball Pin Configuration

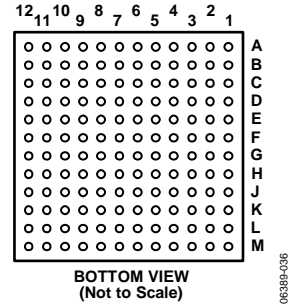

Figure 31. 144-Ball Pin Configuration

**ECPW** 电子产品世界  
.com.cn

Table 16. Pin Function Descriptions

121-Ball Package		144-Ball Package		Mnemonic	Pins Used	Type	Description
Pin No.	Location	Pin No.	Location				
119	L9	132	L12	MCLK	1	I	System Input Clock. See the PLL section.
117	L7	131	L11	$\overline{\text{RESET}}$	1	I	Reset. Causes the ADV212 to immediately reset. $\overline{\text{CS}}$ , $\overline{\text{RD}}$ , $\overline{\text{WE}}$ , $\overline{\text{DACK0}}$ , $\overline{\text{DACK1}}$ , $\overline{\text{DREQ0}}$ , and $\overline{\text{DREQ1}}$ must be held high when a RESET is applied.
37 to 34, 27 to 25, 16, 15, 24, 14 to 12, 2, 6, 5	D4 to D1, C5 to C3, B5, B4, C2, B3 to B1, A2, A6, A5	64, 49 to 51, 37 to 39, 25 to 27, 13 to 15, 2 to 4	F4, E1 to E3, D1 to D3, C1 to C3, B1 to B3, A2 to A4	HDATA [15:0]	16	I/O	Host Data Bus. With HDATA [23:16], HDATA [27:24], and HDATA [31:28], these pins make up the 32-bit wide host data bus. The async host interface is interfaced together with ADDR[3:0], $\overline{\text{CS}}$ , $\overline{\text{WE}}$ , $\overline{\text{RD}}$ , and $\overline{\text{ACK}}$ . Unused HDATA pins should be pulled down via a 10 k $\Omega$ resistor.
88, 107, 87, 97 96	H11, K8, H10, J9 J8	108 to 106, 96 95	J12, J11, J10, H12 H11	ADDR [3:0]	4	I	Address Bus for the Host Interface.
95	J7	94	H10	$\overline{\text{CS}}$	1	I	Chip Select. This signal is used to qualify addressed read and write access to the ADV212 using the host interface.
86	H9	84	G12	$\overline{\text{WE}}^1$ $\overline{\text{RDFB}}^2$	1	I	Write Enable Used with the Host Interface. Read Enable When Fly-By DMA Is Enabled. Simultaneous assertion of $\overline{\text{WE}}$ and $\overline{\text{DACK}}$ low activates the HDATA bus, even if the DMA channels are disabled.
85	H8	83	G11	$\overline{\text{RD}}^1$ $\overline{\text{WEFB}}^3$	1	I	Read Enable Used with the Host Interface. Write Enable When Fly-By DMA Is Enabled. Simultaneous assertion of $\overline{\text{RD}}$ and $\overline{\text{DACK}}$ low activates the HDATA bus, even if the DMA channels are disabled.
76	G10	82	G10	$\overline{\text{ACK}}$	1	O	Acknowledge. Used for direct register accesses. This signal indicates that the last register access was successful. Due to synchronization issues, control and status register accesses might incur an additional delay; therefore, the host software should wait for acknowledgment from the ADV212 before attempting another register access. Accesses to the FIFOs (external DMA modes), on the other hand, are guaranteed to occur immediately, provided that space is available; therefore, the host software does not need to wait for $\overline{\text{ACK}}$ before attempting another register access, provided that the timing constraints are observed. If $\overline{\text{ACK}}$ is shared with more than one device, $\overline{\text{ACK}}$ should be connected to a pull-up resistor (10 k $\Omega$ ) and the PLL_HI register, Bit 4, must be set to 1.
				$\overline{\text{IRQ}}$	1	O	Interrupt. This pin indicates that the ADV212 requires the attention of the host processor. This pin can be programmed to indicate the status of the internal interrupt conditions within the ADV212. The interrupt sources are enabled via the bits in register EIRQIE.

# ADV212

121-Ball Package		144-Ball Package		Mnemonic	Pins Used	Type	Description
Pin No.	Location	Pin No.	Location				
63	F8	72	F12	DREQ0	1	O	Data Request for External DMA Interface. Indicates that the ADV212 is ready to send/receive data to/from the FIFO assigned to DMA Channel 0.
				$\overline{\text{FSRQ0}}$		O	FIFO Service Request. Used in DCS-DMA Mode. Service request from the FIFO assigned to Channel 0 (asynchronous mode).
				$\overline{\text{VALID}}$		O	Valid Indication for JDATA Input/Output Stream. Polarity of this pin is programmable in the EDMOD0 register. VALID is always an output.
				CFG1		I	Boot Mode Configuration. This pin is read on reset to determine the boot configuration of the on-board processor. The pin should be tied to IOVDD or DGND through a 10 kΩ resistor.
64	F9	71	F11	$\overline{\text{DACK0}}$	1	I	Data Acknowledge for External DMA Interface. Signal from the host CPU, which indicates that the data transfer request (DREQ0) has been acknowledged and that the data transfer can proceed. This pin must be held high at all times if the DMA interface is not used, even if the DMA channels are disabled.
				$\overline{\text{HOLD}}$		I	External Hold Indication for JDATA Input/Output Stream. Polarity is programmable in the EDMOD0 register. This pin is always an input.
				$\overline{\text{FCS0}}$		I	FIFO Chip Select. Used in DCS-DMA Mode. Chip select for the FIFO assigned to Channel 0 (asynchronous mode).
65	F10	70	F10	$\overline{\text{DREQ1}}$	1	O	Data Request for External DMA Interface. Indicates that the ADV212 is ready to send/receive data to/from the FIFO assigned to DMA Channel 1.
				$\overline{\text{FSRQ1}}$		O	FIFO Service Request. Used in DCS-DMA Mode. Service request from the FIFO assigned to Channel 1 (asynchronous mode).
				CFG2		I	Boot Mode Configuration. This pin is read on reset to determine the boot configuration of the on-board processor. The pin should be tied to IOVDD or DGND through a 10 kΩ resistor.
75	G9	69	F9	$\overline{\text{DACK1}}$	1	I	Data Acknowledge for External DMA Interface. Signal from the host CPU, which indicates that the data transfer request (DREQ1) has been acknowledged and data transfer can proceed. This pin must be held high at all times unless a DMA or JDATA access is occurring. This pin must be held high at all times if the DMA interface is not used, even if the DMA channels are disabled.
				$\overline{\text{FCS1}}$		I	FIFO Chip Select. Used in DCS-DMA Mode. Chip select for the FIFO assigned to Channel 1 (asynchronous mode).
90 to 92, 78	J2 to J4, H1	111, 97 to 99	K3, J1 to J3	HDATA [31:28] JDATA [7:4]	4	I/O	Host Expansion Bus.
79 to 81, 70	H2 to H4, G4	100, 85 to 87	J4, H1 to H3	HDATA [27:24]	4	I/O	JDATA Bus (JDATA Mode).
				JDATA [3:0]		I/O	Host Expansion Bus.

121-Ball Package		144-Ball Package		Mnemonic	Pins Used	Type	Description
Pin No.	Location	Pin No.	Location				
69, 68, 59, 58	G3, G2, F4, F3	88,73 to 75	H4, G1 to G3	HDATA [23:20]	4	I/O	Host Expansion Bus.
57, 46 to 48	F2, E2, E3, E4	76, 61 to 63	G4, F1 to F3	HDATA [19:16] VDATA [15:12]	4	I/O	Host Expansion Bus.  Video Data. Only used for raw pixel video mode. Unused pins should be pulled down via a 10 kΩ resistor.
112	L2	134	M2	SCOMM7	8	I/O	Serial Communication. For internal use only. This pin should be tied low via a 10 kΩ resistor.
113	L3	135	M3	SCOMM6		I/O	Serial Communication. For internal use only. This pin should be tied low via a 10 kΩ resistor.
114	L4	136	M4	SCOMM5		I/O	Serial Communication. This pin must be used in multiple chip mode to align the outputs of two or more ADV212s. For details, see the Applications section and the <a href="#">AN-796 Application Note</a> . When not used, this pin should be tied low via a 10 kΩ resistor.
100	K1	121	L1	SCOMM4		O	LCODE Output in Encode Mode. When LCODE is enabled, the output on this pin indicates on a high transition that the last data-word for a field has been read from the FIFO. For an 8-bit interface, such as JDATA, LCODE is asserted for four consecutive bytes and is enabled by default.
101	K2	122	L2	SCOMM3		I	Serial Communication. For internal use only. This pin should be tied low via a 10 kΩ resistor.
115	L5	123	L3	SCOMM2		O	Serial Communication. For internal use only. This pin should be tied low via a 10 kΩ resistor.
103	K4	109	K1	SCOMM1		I	Serial Communication. For internal use only. This pin should be tied low via a 10 kΩ resistor.
102	K3	110	K2	SCOMM0		O	Serial Communication. This pin should be tied low via a 10 kΩ resistor.
53	E9	60	E12	VCLK	1	I	Video Data Clock. This pin must be supplied if video data is input/output on the VDATA bus.
44, 43, 29, 31, 32, 18 to 20, 22, 21, 7, 10	D11, D10, C7, C9, C10, B7, B8, B9, B11, B10, A7, A10	46 to 48, 34 to 36, 22 to 24, 9 to 11	D10 to D12, C10 to C12, B10 to B12, A9 to A11	VDATA [11:0]	12	I/O	Video Data. Unused pins should be pulled down via a 10 kΩ resistor.
41	D8	58	E10	VSYNC VFRM	1	I/O	Vertical Sync for Video Mode. Raw Pixel Mode Framing Signal. When this pin is asserted high, it indicates the first sample of a tile.
42	D9	59	E11	HSYNC VRDY	1	I/O O	Horizontal Sync for Video Mode. Raw Pixel Mode Ready Signal.
54	E10	57	E9	FIELD VSTRB	1	I/O I	Field Sync for Video Mode. Raw Pixel Mode Transfer Strobe.
94	J6	120	K12	TCK	1	I	JTAG Clock. If not used, this pin should be connected to ground via a pull-down resistor.
108	K9	119	K11	TRS	1	I	JTAG Reset. If the JTAG is used, this pin must be toggled low to high. If JTAG is not used, this pin must be held low.

# ADV212

121-Ball Package		144-Ball Package		Mnemonic	Pins Used	Type	Description
Pin No.	Location	Pin No.	Location				
98	J10	118	K10	TMS	1	I	JTAG Mode Select. If JTAG is used, connect 10 kΩ pull-up resistor to this pin. If not used, this pin should be connected to ground via a pull-down resistor.
116	L6	141	M9	TDI	1	I	JTAG Serial Data Input. If JTAG is used, connect a 10 kΩ pull-up resistor to this pin. If JTAG is not used, this pin should be connected to ground via a pull-down resistor.
109	K10	130	L10	TDO	1	O	JTAG Serial Data Output. If this pin is not used, do not connect it.
3, 8, 40, 84, 120	A3, A8, D7, H7, L10	18, 19, 30, 31, 42, 43, 102, 103, 114, 115, 126, 127, 142	B6, B7, C6, C7, D6, D7, J6, J7, K6, K7, L6, L7, M10	VDD		V	Positive Supply for Core.
1, 4, 9, 11, 23, 33, 39, 45, 49 to 51, 55, 56, 60 to 62, 66, 67, 71 to 73, 77, 83, 89, 99, 110, 111, 118, 121	A1, A4, A9, A11, C1, C11, D6, E1, E5 to E7, E11, F1, F5 to F7, F11, G1, G5 to G7, G11, H6, J1, J11, K11, L1, L8, L11	1, 5 to 8, 12, 17, 20, 29, 32, 41, 44, 52 to 56, 65 to 68, 77 to 81, 89 to 93, 101, 104, 105, 113, 116, 125, 128, 133, 137 to 140, 143, 144	A1, A5 to A8, A12, B5, B8, C5, C8, D5, D8, E4 to E8, F5 to F8, G5 to G9, H5 to H9, J5, J8, J9, K5, K8, L5, L8, M1, M5 to M8, M11, M12	DGND		GND	Ground.
17, 28, 30, 38, 52, 74, 82, 93, 104 to 106	B6, C6, C8, D5, E8, G8, H5, J5, K5 to K7	16, 21, 28, 33, 40, 45, 112, 117, 124, 129	B4, B9, C4, C9, D4, D9, K4, K9, L4, L9	IOVDD		V	Positive Supply for Input/Output.

<sup>1</sup> In fly-by mode DMA, the function of the  $\overline{RD}$  and  $\overline{WE}$  signals (for DMA only) are reversed. This allows a host to move data between an external device and the ADV212 with the use of a single strobe.

<sup>2</sup> In encode mode with fly-by DMA, the host can use the  $\overline{RDFB}$  signal ( $\overline{WE}$  pin) to simultaneously read from the ADV212 and write to an external device like memory.

<sup>3</sup> In decode mode with fly-by DMA, the host can use the  $\overline{WEFB}$  signal ( $\overline{RD}$  pin) to simultaneously read from the external device and write to the ADV212.



## THEORY OF OPERATION

The input video or pixel data is passed on to the ADV212's pixel interface, and samples are deinterleaved and passed on to the wavelet engine, which decomposes each tile or frame into subbands using the 5/3 or 9/7 filters. The resultant wavelet coefficients are then written to the internal memory. The entropy codecs code the image data so that it conforms to the JPEG 2000 standard. An internal DMA provides high bandwidth memory-to-memory transfers, as well as high performance transfers between functional blocks and memory.

### WAVELET ENGINE

The ADV212 provides a dedicated wavelet transform processor based on the Analog Devices proven and patented SURF technology. This processor can perform up to six wavelet decomposition levels on a tile. In encode mode, the wavelet transform processor takes in uncompressed samples, performs the wavelet transform and quantization, and writes the wavelet coefficients in all frequency subbands to the internal memory. Each of these subbands is further broken down into code blocks. The code-block dimensions can be user defined and are used by the wavelet transform processor to organize the wavelet coefficients into code blocks when writing to the internal memory. Each completed code block is then entropy coded by one of the entropy codecs.

In decode mode, wavelet coefficients are read from internal memory and recomposed into uncompressed samples.

### ENTROPY CODECS

The entropy codec block performs context modeling and arithmetic coding on a code block of the wavelet coefficients. Additionally, this block also performs the distortion metric calculations during compression that are required for optimal rate and distortion performance. Because the entropy coding process is the most computationally intensive operation in the JPEG 2000 compression process, three dedicated hardware entropy codecs are provided on the ADV212.

### EMBEDDED PROCESSOR SYSTEM

The ADV212 incorporates an embedded 32-bit RISC processor. This processor is used for configuration, control, and management of the dedicated hardware functions, as well as for parsing and generation of the JPEG 2000 code stream. The processor system includes memory for both the program and data memory, the interrupt controller, the standard bus interfaces, and other hardware functions such as timers and counters.

### MEMORY SYSTEM

The main function of the memory system is to manage wavelet coefficient data, interim code-block attribute data, and temporary workspace for creating, parsing, and storing the JPEG 2000 code stream. The memory system can also be used for the program and data memory for the embedded processor.

### INTERNAL DMA ENGINE

The internal DMA engine provides high bandwidth memory-to-memory transfers, as well as high performance transfers between memory and functional blocks. This function is critical for high speed generation and parsing of the code stream.

# ADV212

## ADV212 INTERFACE

There are several possible modes to interface to the ADV212 using the VDATA bus and the HDATA bus or the HDATA bus alone.

### VIDEO INTERFACE (VDATA BUS)

The video interface can be used in applications in which uncompressed pixel data is on a separate bus from compressed data. For example, it is possible to use the VDATA bus to input uncompressed video while using the HDATA bus to output the compressed data. This interface is ideal for applications requiring very high throughput, such as live video capture.

Optionally, the ADV212 interlaces ITU-R BT.656 resolution video on the fly prior to wavelet processing, which yields significantly better compression performance for temporally coherent frame-based video sources. Additionally, high definition digital video such as SMPTE 274M (1080i) is supported using two or more ADV212 devices.

The video interface can support video data or still image data input/output in 8-/10-/12-bit formats, in YCbCr format, or in single input mode. YCbCr data must be in 4:2:2 format.

Video data can be input/output in several different modes on the VDATA bus, as described in Table 17. In all these modes, the pixel clock must be input on the VCLK pin.

Table 17. Video Input/Output Modes

Mode	Description
EAV/SAV	Accepts video with embedded EAV/SAV codes, where the YCbCr data is interleaved onto a single bus.
HVF	Accepts video data accompanied with separate H, V, and F signals, where YCbCr data is interleaved onto a single bus.
Raw Video	Used for still picture data and nonstandard video. VFRM, VSTRB, and VRDY are used to program the dimensions of the image.

### HOST INTERFACE (HDATA BUS)

The ADV212 can connect directly to a wide variety of host processors and ASICs using an asynchronous SRAM-style interface, DMA accesses, or streaming mode (JDATA) interface. The ADV212 supports 16- and 32-bit buses for control and 8-/16-/32-bit buses for data transfer.

The control and data channel bus widths can be specified independently, which allows the ADV212 to support applications that require control and data buses of different widths.

The host interface is used for configuration, control, and status functions, as well as for transferring compressed data streams. It can be used for uncompressed data transfers in certain modes. The host interface can be shared by as many as three concurrent data streams in addition to control and status communications. The data streams are

- Uncompressed tile data (for example, still image data)
- Fully encoded JPEG 2000 code stream (or unpackaged code blocks)
- Code-block attributes

The ADV212 uses big endian byte alignment for 16- and 32-bit transfers. All data is left-justified (MSB).

### Pixel Input on the Host Interface

Pixel input on the host interface supports 8-/10-/12-/14-/16-bit raw pixel data formats. It can be used for pixel (still image) input/output or compressed video output. Because there are no timing codes or sync signals associated with the input data on the host interface, dimension registers and internal counters are used and must be programmed to indicate the start and end of the frame. Refer to the [ADV202 in HIPI Mode technical note](#) for information about using the ADV212 in this mode.

### Host Bus Configuration

For maximum flexibility, the host interface provides several configurations to meet particular system requirements. The default bus mode uses the same pins to transfer control, status, and data to and from the ADV212. In this mode, the ADV212 can support 16- and 32-bit control transfers and 8-/16-/32-bit data transfers. The size of these buses can be selected independently, allowing, for example, a 16-bit microcontroller to configure and control the ADV212 while still providing 32-bit data transfers to an ASIC or external memory system.

### DIRECT AND INDIRECT REGISTERS

To minimize pin count and cost, the number of address pins is limited to four, which yields a total direct address space of 16 locations. These locations are most commonly used by the external controller and are, therefore, accessible directly. All other registers in the ADV212 can be accessed indirectly through the IADDR and IDATA registers.

## CONTROL ACCESS REGISTERS

With the exception of the indirect address and data registers (IADDR and IDATA), all control/status registers in the ADV212 are 16 bits wide and are half-word (16-bit) addressable only. When 32-bit host mode is enabled, the upper 16 bits of the HDATA bus are ignored on writes and return all zeros on reads of 16-bit registers.

## PIN CONFIGURATION AND BUS SIZES/MODES

The ADV212 provides a wide variety of control and data configurations, which allows it to be used in many applications with little or no glue logic. The modes described in this section are configured using the BUSMODE register. In this section, *host* refers to normal addressed accesses ( $\overline{CS}/\overline{RD}/\overline{WE}/\overline{ADDR}$ ) and *data* refers to external DMA accesses ( $\overline{DREQ}/\overline{DACK}$ ).

### 32-Bit Host/32-Bit Data

In this mode, the HDATA<31:0> pins provide full 32-bit wide data access to PIXEL, CODE, ATTR FIFOs.

### 16-Bit Host/32-Bit Data

This mode allows a 16-bit host to configure and communicate with the ADV212 while allowing 32-bit accesses to the PIXEL, CODE, ATTR FIFOs using the external DMA capability.

All addressed host accesses are 16 bits and, therefore, use only the HDATA<15:0> pins. The HDATA<31:16> pins provide the additional 16 bits necessary to support the 32-bit external DMA transfers to and from the FIFOs only.

### 16-Bit Host/16-Bit Data

This mode uses 16-bit transfers if used for host or external DMA data transfers.

### 16-Bit Host/8-Bit Data (JDATA Bus Mode)

This mode provides separate data input/output and host control interface pins. Host control accesses are 16 bits and use HDATA<15:0>, whereas the dedicated data bus uses JDATA<7:0>.

JDATA uses a valid/hold synchronous transfer protocol. The direction of the JDATA bus is determined by the mode of the ADV212. If the ADV212 is encoding (compression), JDATA<7:0> is an output. If the ADV212 is decoding (decompression), JDATA<7:0> is an input. Host control accesses remain asynchronous. See also JDATA section below.

## STAGE REGISTER

Because the ADV212 contains both 16-bit and 32-bit registers and its internal memory is mapped as 32-bit data, a mechanism

has been provided to allow 16-bit hosts to access these registers and memory locations using the stage register (STAGE). STAGE is accessed as a 16-bit register using HDATA [15:0]. Prior to writing to the desired register, the stage register must be written with the upper (most significant) half-word.

When the host subsequently writes the lower half-word to the desired control register, HDATA is combined with the previously staged value to create the required 32-bit value that is written. When a register is read, the upper (most significant) half-word is returned immediately on HDATA and the lower half-word can be retrieved by reading the stage register on a subsequent access. For details on using the stage register, see the [ADV212 User's Guide](#).

Note that the stage register does not apply to the three data channels (PIXEL, CODE, ATTR). These channels are always accessed at the specified data width and do not require the use of the stage register.

## JDATA MODE

JDATA mode is typically used only when the dedicated video interface (VDATA) is also enabled. This mode allows code stream data (compressed data compliant with JPEG 2000) to be input or output on a single dedicated 8-bit bus (JDATA<7:0>). The bus is always an output during compression operations, and is an input during decompression.

A 2-pin handshake is used to transfer data over this synchronous interface. VALID is used to indicate that the ADV212 is ready to provide or accept data and is always an output. HOLD is always an input and is asserted by the host if it cannot accept/provide data. For example, JDATA mode allows real-time applications, in which pixel data is input over the VDATA bus while the compressed data stream is output over the JDATA bus.

## EXTERNAL DMA ENGINE

The external DMA interface is provided to enable high bandwidth data input/output between an external DMA controller and the ADV212 data FIFOs. Two independent DMA channels can each be assigned to any one of the three data stream FIFOs (PIXEL, CODE, ATTR).

The controller supports asynchronous DMA using a data-request/data-acknowledge ( $\overline{DREQ}/\overline{DACK}$ ) protocol in either single or burst access modes. Additional functionality is provided for single address compatibility (fly-by) and dedicated chip select (DCS) modes.

# ADV212

## INTERNAL REGISTERS

This section describes the internal registers of the ADV212.

### DIRECT REGISTERS

The ADV212 has 16 direct registers, as listed in Table 18. The direct registers are accessed over the ADDR [3:0], HDATA [31:0],  $\overline{\text{CS}}$ ,  $\overline{\text{RD}}$ ,  $\overline{\text{WE}}$ , and  $\overline{\text{ACK}}$  pins.

The host must first initialize the direct registers before any application-specific operation can be implemented.

For additional information on accessing and configuring these registers, see the [ADV212 User's Guide](#).

Table 18. Direct Registers

Address	Name	Description
0x00	PIXEL	Pixel FIFO access register
0x01	CODE	Compressed code stream access register
0x02	ATTR	Attribute FIFO access register
0x03	Reserved	Reserved
0x04	CMDSTA	Command stack
0x05	EIRQIE	External interrupt enabled
0x06	EIRQFLG	External interrupt flags
0x07	SWFLAG	Software flag register
0x08	BUSMODE	Bus mode configuration register
0x09	MMODE	Miscellaneous mode register
0x0A	STAGE	Staging register
0x0B	IADDR	Indirect address register
0x0C	IDATA	Indirect data register
0x0D	BOOT	Boot mode register
0x0E	PLL_HI	PLL control register—high byte
0x0F	PLL_LO	PLL control register—low byte

**INDIRECT REGISTERS**

In certain modes, such as custom-specific input format or HIPI mode, indirect registers must be accessed by the user through the use of the IADDR and IDATA registers. The indirect register address space starts at Internal Address 0xFFFF0000.

Both 32-bit and 16-bit hosts can access the indirect registers. 32-bit hosts use the IADDR and IDATA registers, and the 16-bit hosts use the IADDR, the IDATA, and the stage register.

For additional information on accessing and configuring these registers, see the *ADV212 User's Guide*.

**Table 19. Indirect Registers**

Address	Name	Description
0xFFFF0400	PMODE1	Pixel/video format
0xFFFF0404	COMP_CNT_STATUS	Horizontal count
0xFFFF0408	LINE_CNT_STATUS	Vertical count
0xFFFF040C	XTOT	Total samples per line
0xFFFF0410	YTOT	Total lines per frame
0xFFFF0414	F0_START	Start line of Field 0 [F0]
0xFFFF0418	F1_START	Start line of Field 1 [F1]
0xFFFF041C	V0_START	Start of active video Field 0 [F0]
0xFFFF0420	V1_START	Start of active video Field 1 [F1]
0xFFFF0424	V0_END	End of active video Field 0 [F0]
0xFFFF0428	V1_END	End of active video Field 1 [F1]
0xFFFF042C	PIXEL_START	Horizontal start of active video
0xFFFF0430	PIXEL_END	Horizontal end of active video
0xFFFF0440	MS_CNT_DEL	Master/slave delay
0xFFFF0444	Reserved	Reserved
0xFFFF0448	PMODE2	Pixel Mode 2
0xFFFF044C	VMODE	Video mode
0xFFFF1408	EDMOD0	External DMA Mode Register 0
0xFFFF140C	EDMOD1	External DMA Mode Register 1
0xFFFF1410	FFTHRP	FIFO threshold for pixel FIFO
0xFFFF1414	Reserved	Reserved
0xFFFF1418	Reserved	Reserved
0xFFFF141C	FFTHRC	FIFO threshold for code FIFO
0xFFFF1420	FFTHRA	FIFO threshold for ATTR FIFO
0xFFFF1424 to 0xFFFF14FC	Reserved	Reserved



**HARDWARE BOOT**

The boot mode can be configured via hardware using the CFG pins or via software. The first boot mode after power-up is set by the CFG pins.

**Table 22. Hardware Boot Modes**

<b>Boot Mode</b>	<b>Settings</b>	<b>Description</b>
Hardware Boot Mode 2	CFG<1> tied high, CFG<2> tied low	No boot host mode. ADV212 does not boot, but all internal registers and memory are accessible through normal host input/output operations.
Hardware Boot Mode 4	CFG<1> tied low, CFG<2> tied high	Reserved.
Hardware Boot Mode 6	CFG<1> and CFG<2> tied high	Reserved.

EEPW 电子產品世界  
.com.cn



# ADV212

## VIDEO INPUT FORMATS

The ADV212 supports a wide variety of formats for uncompressed video and still image data. The actual interface and bus modes selected for transferring uncompressed data dictates the allowed size of the input data and the number of samples transferred with each access.

The host interface can support 8-/10-/12-/14-/16-bit data formats. The video interface can support video data or still image data input/output. Supported formats are 8-/10-/12-bit

YCbCr formats or single component format. See the [ADV212 User's Guide](#) for details. All formats can support less precision than provided by specifying the actual data width/precision in the PMODE register.

The maximum allowable data input rate is limited by using irreversible or reversible compression modes and the data width (or precision) of the input samples. Refer to Table 23 and Table 25 to determine the maximum data input rate.

**Table 23. Maximum Pixel Data Input Rates (144-Ball Package)**

Interface	Compression Mode	Input Format	Input Rate Limit Active Resolution (MSPS) <sup>1</sup>	Approx Min Output Rate, Compressed Data <sup>2</sup> (Mbps)	Approx Max Output Rate, Compressed Data <sup>3</sup> (Mbps)
HDATA	Irreversible	8-bit data	45	130	200
	Irreversible	10-bit data	45	130	200
	Irreversible	12-bit data	45	130	200
	Irreversible	16-bit data	45	130	200
	Reversible	8-bit data	40	130	200
	Reversible	10-bit data	32	130	200
	Reversible	12-bit data	27	130	200
	Reversible	14-bit data	23	130	200
VDATA	Irreversible	8-bit data	65	130	200
	Irreversible	10-bit data	65	130	200
	Irreversible	12-bit data	65	130	200
	Reversible	8-bit data	40	130	200
	Reversible	10-bit data	32	130	200
	Reversible	12-bit data	27	130	200

<sup>1</sup> Input rate limits for HDATA might be less for certain applications depending on input picture size and content, host interface settings, and DMA transfer settings.

<sup>2</sup> Minimum guaranteed sustained output rate or minimum sustainable compression rate [input rate/minimum peak output rate].

<sup>3</sup> Maximum peak output rate; an output rate above this value is not possible.

**Table 24. Maximum Pixel Data Input Rates (121-Ball Package)**

Interface	Compression Mode	Input Format	Input Rate Limit Active Resolution (MSPS) <sup>1</sup>	Approx Min Output Rate, Compressed Data <sup>2</sup> (Mbps)	Approx Max Output Rate, Compressed Data <sup>3</sup> (Mbps)
HDATA	Irreversible	8-bit data	34	98	150
	Irreversible	10-bit data	34	98	150
	Irreversible	12-bit data	34	98	150
	Irreversible	16-bit data	34	98	150
	Reversible	8-bit data	30	98	150
	Reversible	10-bit data	24	98	150
	Reversible	12-bit data	20	98	150
	Reversible	14-bit data	17	98	150
VDATA	Irreversible	8-bit data	48	98	150
	Irreversible	10-bit data	48	98	150
	Irreversible	12-bit data	48	98	150
	Reversible	8-bit data	30	98	150
	Reversible	10-bit data	24	98	150
	Reversible	12-bit data	20	98	150

<sup>1</sup> Input rate limits for HDATA might be less for certain applications depending on input picture size and content, host interface settings, and DMA transfer settings.

<sup>2</sup> Minimum guaranteed sustained output rate or minimum sustainable compression rate [input rate/minimum peak output rate].

<sup>3</sup> Maximum peak output rate; an output rate above this value is not possible.



Table 25. Maximum Supported Tile Width for Data Input on HDATA and VDATA Buses

Compression Mode	Input Format	Tile/Precinct Maximum Width
9/7i	Single-component	2048
9/7i	Two-component	1024 each
9/7i	Three-component	1024 (Y)
5/3i	Single-component	4096
5/3i	Two-component	2048 (each)
5/3i	Three-component	2048 (Y)
5/3r	Single-component	4096
5/3r	Two-component	2048
5/3r	Three-component	1024

EEPW 电子产品世界  
.com.cn

# ADV212

## APPLICATIONS

This section describes typical video applications for the ADV212 JPEG 2000 video processor.

### ENCODE—MULTICHIP MODE

Due to the data input rate limitation (see Table 23), an 1080i application requires at least two ADV212s to encode or decode full-resolution 1080i video. In encode mode, the ADV212 accepts Y and CbCr data on separate buses. An encode example is shown in Figure 33.

In decode mode, a master/slave configuration (as shown in Figure 34) or a slave/slave configuration can be used to synchronize the outputs of the two ADV212s. See the [AN-796 Application Note](#) for details on how to configure the ADV212s in a multichip application.

Applications that have two separate VDATA outputs sent to an FPGA or buffer before they are sent to an encoder do not require synchronization at the ADV212 outputs.

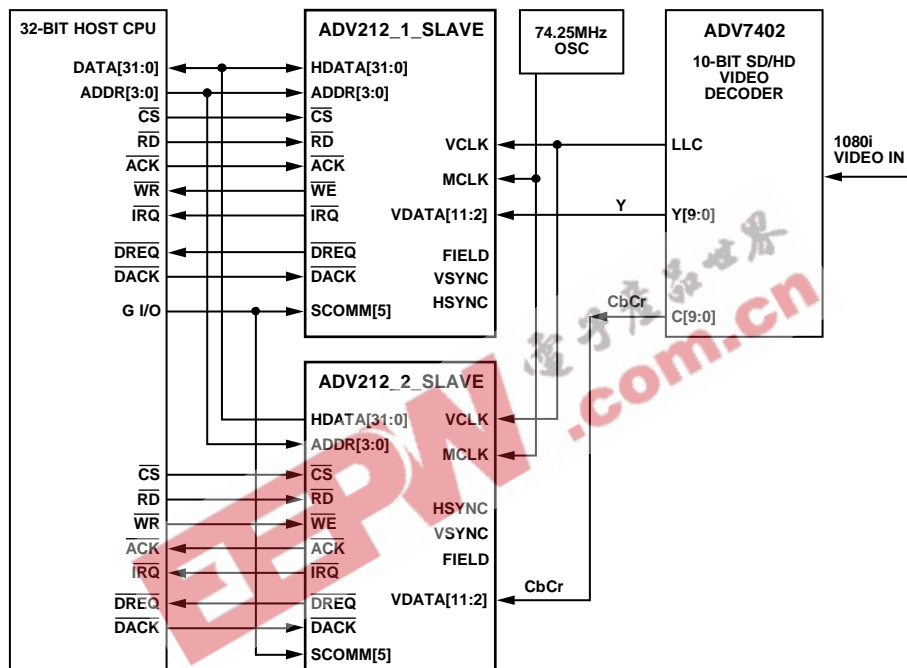

Figure 33. Encode—Multichip Application

06389-002

**DECODE—MULTICHIP MASTER/SLAVE**

In a master/slave configuration, it is expected that the master HVF outputs are connected to the slave HVF inputs and that each SCOMM[5] pin is connected to the same GPIO on the host.

In a slave/slave configuration, the common HVF for both ADV212s is generated by an external house sync and each SCOMM[5] is connected to the same GPIO output on the host. SWIRQ1, Software Interrupt 1 in the EIRQIE register, must be unmasked on both devices to enable multichip mode.

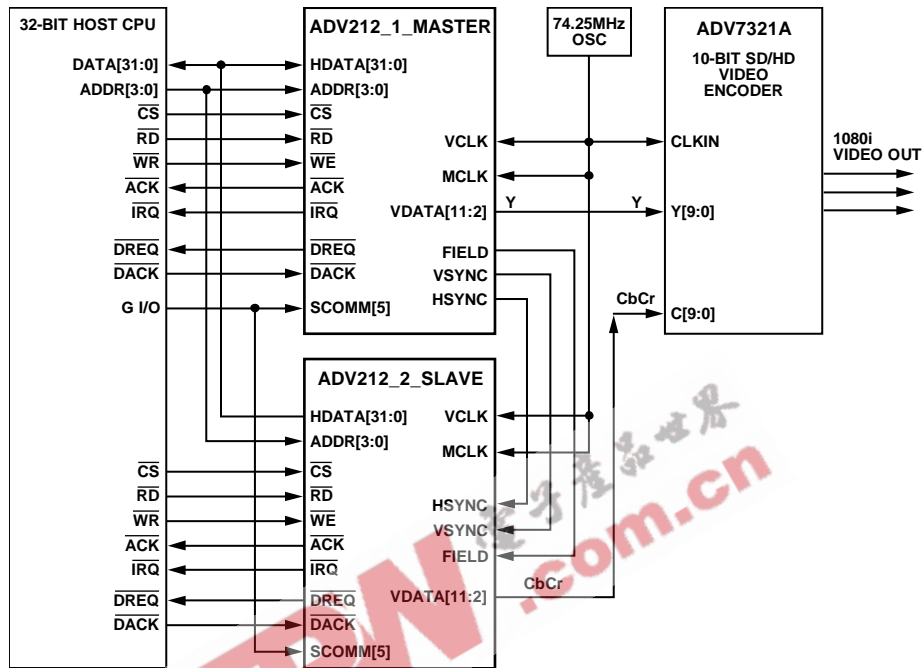

Figure 34. Decode—Multichip Master/Slave Application

063389-0/03

# ADV212

## DIGITAL STILL CAMERA/CAMCORDER

Figure 35 is a typical configuration for a digital camera or camcorder.

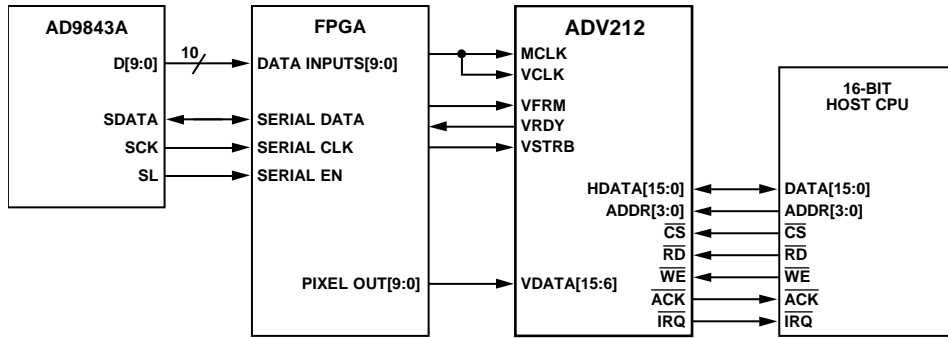

Figure 35. Digital Still Camera/Camcorder Encode Application for 10-Bit Pixel Data Using Raw Pixel Mode

06385-004

EEPW.com.cn 电子产品世界

**ENCODE/DECODE SDTV VIDEO APPLICATION**

Figure 36 shows two ADV212 chips using a 10-bit CCIR 656 in normal host mode.

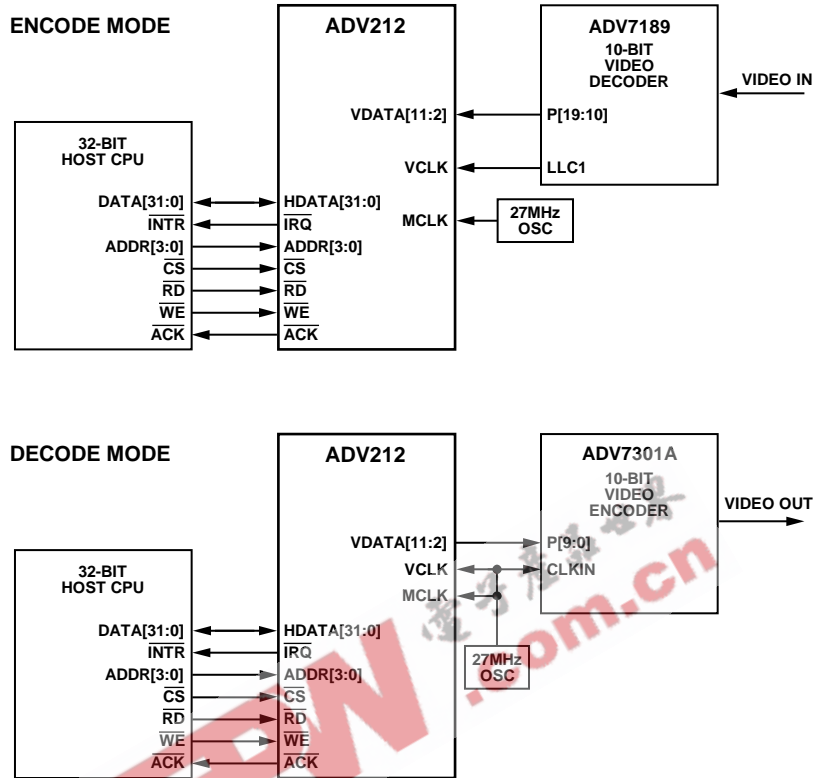

Figure 36. Encode/Decode—SDTV Video Application

06389-005

# ADV212

## 32-BIT HOST APPLICATION

Figure 37 shows two ADV212 chips using a 10-bit CCIR 656 in normal host mode.

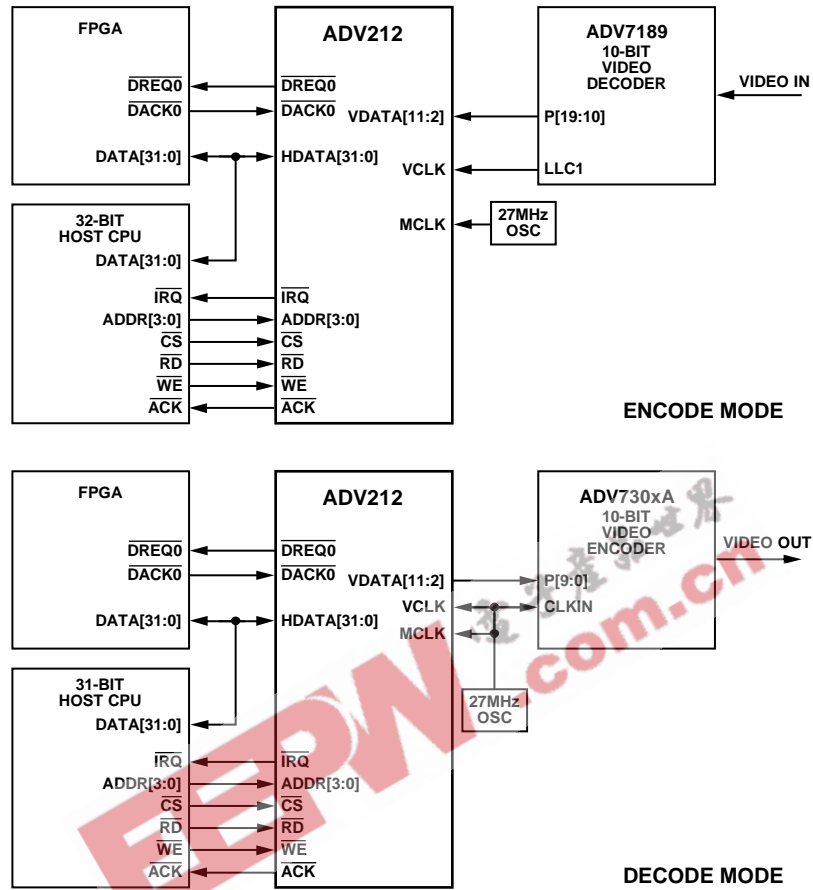

Figure 37. Encode/Decode 32-Bit Host Application

063389-006

**HIPI (HOST INTERFACE—PIXEL INTERFACE)**

Figure 38 is a typical configuration using HIPI mode.

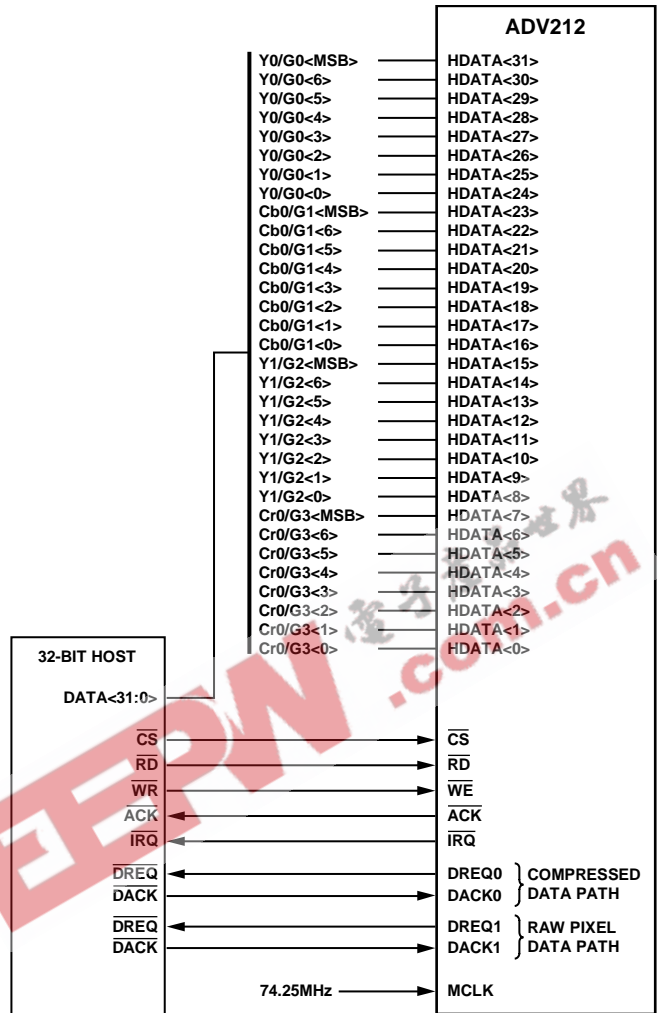

Figure 38. Host Interface—Pixel Interface Mode

# ADV212

## JDATA INTERFACE

Figure 39 shows a typical configuration using JDATA with a dedicated JDATA output, 16-bit host, and 10-bit CCIR 656.

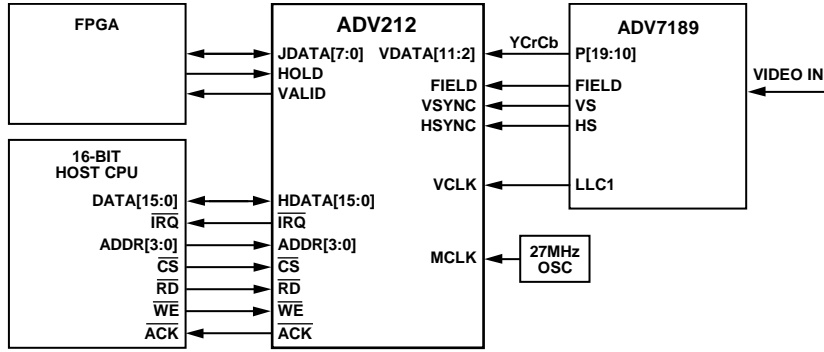

Figure 39. JDATA Application

06319-0/0

EEPW.com.cn 电子产品世界



OUTLINE DIMENSIONS

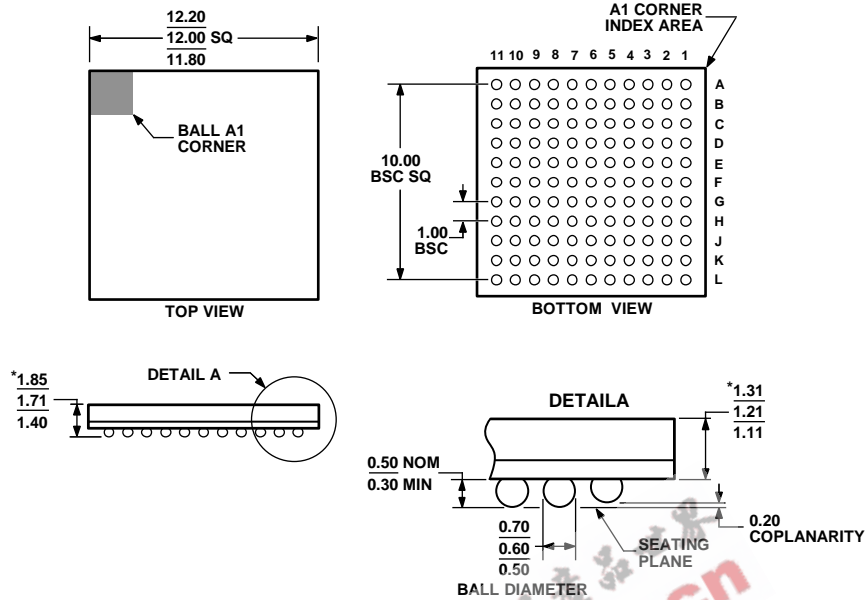

\*COMPLIANT WITH JEDEC STANDARDS MO-192-ABD-1 WITH EXCEPTION TO PACKAGE HEIGHT AND THICKNESS.

Figure 40. 121-Ball Chip Scale Package Ball Grid Array [CSP\_BGA] (BC-121-1)

Dimensions shown in millimeters

082406-A

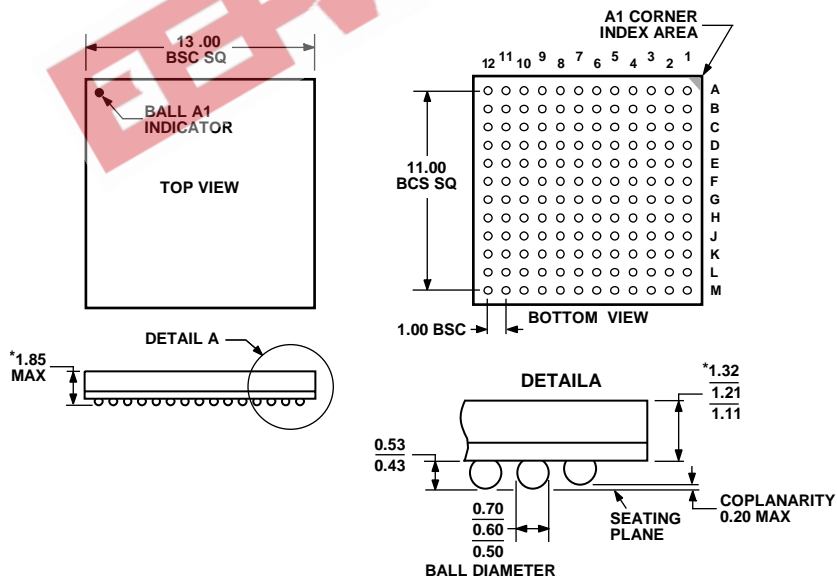

\*COMPLIANT WITH JEDEC STANDARDS MO-192-AAD-1 WITH EXCEPTION TO PACKAGE HEIGHT AND THICKNESS.

Figure 41. 144-Ball Chip Scale Package Ball Grid Array [CSP\_BGA] (BC-144-3)

Dimensions shown in millimeters

021506-A

# ADV212

## ORDERING GUIDE

Model	Temperature Range	Speed Grade	Operating Voltage	Package Description	Package Option
ADV212BBCZ-115 <sup>1</sup>	-40°C to +85°C	115 MHz	1.5 V Internal, 2.5 V or 3.3 V I/O	121-Ball Chip Scale Package Ball Grid Array [CSP_BGA]	BC-121-1
ADV212BBCZRL-115 <sup>1</sup>	-40°C to +85°C	115 MHz	1.5 V Internal, 2.5 V or 3.3 V I/O	121-Ball Chip Scale Package Ball Grid Array [CSP_BGA]	BC-121-1
ADV212BBCZ-150 <sup>1</sup>	-40°C to +85°C	150 MHz	1.5 V Internal, 2.5 V or 3.3 V I/O	144-Ball Chip Scale Package Ball Grid Array [CSP_BGA]	BC-144-3
ADV212BBCZRL-150 <sup>1</sup>	-40°C to +85°C	150 MHz	1.5 V Internal, 2.5 V or 3.3 V I/O	144-Ball Chip Scale Package Ball Grid Array [CSP_BGA]	BC-144-3

<sup>1</sup> Z = Pb-free part.

EEPW 电子产品世界  
.com.cn

NOTES



ADV212

NOTES

EEPW 电子产品世界  
.com.cn