



T-58-07
10V + 5V References

ADREF01/ADREF02

FEATURES

- Replacement for Industry Standard REF01/REF02
- Laser Trimmed to High Accuracy:
 - 10.000V \pm 30mV (REF01)
 - 5.000V \pm 15mV (REF02)
 - (A and E Grades)
- Trimmed Temperature Coefficient: 8.5ppm/ $^{\circ}$ C max (A and E Grades)
- Low Noise: 4 μ V p-p Typical
- Output Trim Capability
- Temperature Output Pin (REF02)
- Machine Insertable Hermetic Cerdip Package

ADREF01 FUNCTIONAL BLOCK DIAGRAM

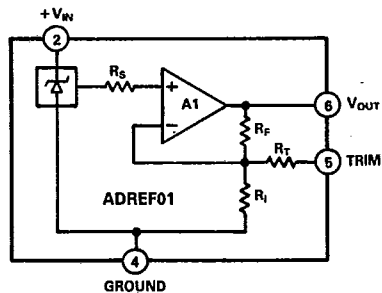

NOTE: MAKE NO CONNECTIONS TO PINS 1, 3, 7 AND 8.

ADREF02 FUNCTIONAL BLOCK DIAGRAM

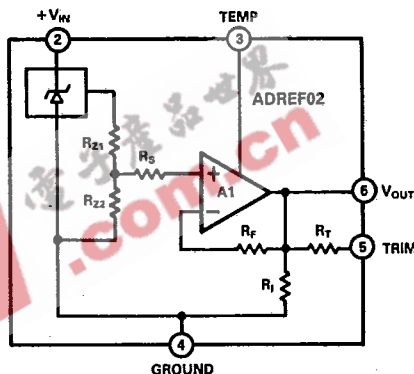

NOTE: PINS 1, 7 & 8 ARE INTERNAL TEST POINTS. MAKE NO CONNECTIONS TO THESE POINTS.

PRODUCT DESCRIPTION

The ADREF01 and ADREF02 are a 10V and 5V reference, respectively, that utilize a buried Zener diode for minimal noise and drift over temperature. The Zener diode provides a precise 10.0V (5.0V for REF02) output from an unregulated input voltage of 13.5V (10.8V for REF02) to 36V. Laser Wafer Trimming (LWT) is used to trim both the initial error at +25 $^{\circ}$ C as well as the temperature coefficient.

The +10V output can be adjusted over a +3%, -1% range with minimal effect on device characteristics. The +5V output can also be adjusted over a +6%, -2% range with minimal effect on device characteristics. The ADREF01 and ADREF02 offer good drift characteristics, low power consumption, and good accuracy for applications requiring a low-cost reference.

These devices are recommended as references for 8-, 10- and 12-bit D/A converters that require an external reference. They are also ideal for all types of A/D converters with up to 12-bit accuracy.

The ADREF01E/ADREF02E and ADREF01H/ADREF02H are specified for operation from 0 to +70 $^{\circ}$ C, and the ADREF01/ADREF02 and ADREF01A/ADREF02A are specified for operation between -55 $^{\circ}$ C and +125 $^{\circ}$ C. All grades are packaged in a hermetic 8-pin cerdip package.

PRODUCT HIGHLIGHTS

1. The ADREF01 is a second source equivalent to the industry standard REF01.
2. The ADREF01 provides a stable 10.000V output for input voltages between 13.5V and 36V.
3. Laser Wafer Trimming reduces ADREF01 initial offset error to 30mV (A and E grades).
4. The ADREF02 is a second source equivalent to the industry standard REF02.

5. The ADREF02 provides a stable 5.000V output for input voltages between 10.8V and 36V.
6. Laser Wafer Trimming reduces ADREF02 initial offset error to 15mV (A and E grades).
7. Temperature out pin enables the ADREF02 to be configured as a temperature transducer.
8. The buried Zener diode reference on both devices reduces noise to 4 μ V p-p and improves temperature stability to 8.5ppm/ $^{\circ}$ C max (A and E grades).
9. Cerdip packaging provides hermeticity and machine insertability at a low price for the devices.

SPECIFICATIONS ($T_A = +25^\circ\text{C}$, $V_{IN} = +15\text{V}$ unless otherwise specified)

T-58-07

Model	ADREF01H			ADREF01E			ADREF01			ADREF01A			Units
	Min	Typ	Max	Min	Typ	Max	Min	Typ	Max	Min	Typ	Max	
Output Voltage	9.950 10.050			9.970 10.030			9.950 10.050			9.970 10.030			V
Output Voltage Drift 0 to +70°C -55°C to +125°C	10 25			3 8.5			10 25			3 8.5			± ppm/°C
Gain Adjustment	-1 +3			-1 +3			-1 +3			-1 +3			%
Line Regulation (T_{min} to T_{max}) 13.5V ≤ V_{IN} ≤ 36V	100			100			100			100			± μV/V
Load Regulation Sourcing $0 < I_{OUT} < 10\text{mA}$ T_{min} to T_{max} Sinking $-10 < I_{OUT} < 0\text{mA}$ T_{min} to T_{max}	100			100			100			100			± μV/mA
Quiescent Current	2 4			2 4			2 4			2 4			mA
Power Dissipation	30			30			30			30			mW
Output Noise 0.1Hz to 10Hz Spectral Density, 100Hz	4 100			4 100			4 100			4 100			μV p-p nV/√Hz
Long-Term Stability	15			15			15			15			ppm/1000Hr
Short-Circuit Current-to-Ground	30 50			30 50			30 50			30 50			mA
Short-Circuit Current-to- V_{IN}	30 50			30 50			30 50			30 50			mA
Turn-On Settling Time to 0.01% FS	60			60			60			60			μs
Temperature Range Specified Performance	0 +70			0 +70			-55 +125			-55 +125			°C

NOTE

Specifications subject to change without notice.

Specifications in boldface are tested on all production units at final electrical test. Results from those tests are used to calculate outgoing quality levels. All min and max specifications are guaranteed, although only those shown in boldface are tested on all production units.

ABSOLUTE MAXIMUM RATINGS* (ADREF01 and ADREF02)

- V_{IN} to Ground 36V
- Power Dissipation (25°C) 500mW
- Storage Temperature -65°C to +150°C
- Lead Temp (Soldering, 10sec) 300°C
- Package Thermal Resistance
- θ_{JC} 22°C/W
- θ_{JA} 110°C/W

Output Protection: Output safe for indefinite short to ground and momentary short to V_{IN} .

*Stresses above those listed under "Absolute Maximum Ratings" may cause permanent damage to the device. This is a stress rating only and functional operation of the device at these or any other conditions above those indicated in the operational sections of this specification is not implied. Exposure to absolute maximum rating conditions for extended periods may affect device reliability.

PIN CONFIGURATIONS

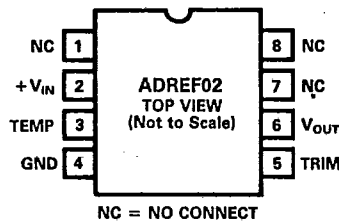
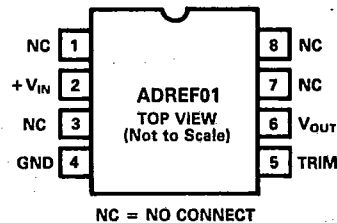

SPECIFICATIONS ($T_A = +25^\circ\text{C}$, $V_M = +15\text{V}$ unless otherwise specified)

ADREF01/ADREF02

T-58-07

Model	ADREF02H			ADREF02E			ADREF02			ADREF02A			Units
	Min	Typ	Max	Min	Typ	Max	Min	Typ	Max	Min	Typ	Max	
Output Voltage	4.975		5.025	4.985		5.015	4.975		5.025	4.985		5.015	V
Output Voltage Drift 0 to +70°C -55°C to +125°C		10	25		3	8.5		10	25		3	8.5	ppm/°C
Gain Adjustment	-2 +6			-2 +6			-2 +6			-2 +6			% %
Line Regulation (T_{\min} to T_{\max}) 10.8V < V_{IN} < 36V 11.4V < V_{IN} < 36V			100			100			150			150	$\pm \mu\text{V/V}$
Load Regulation Sourcing $0 < I_{\text{OUT}} < 10\text{mA}$ +25°C T_{\min} to T_{\max} Sinking $-10 < I_{\text{OUT}} < 0\text{mA}$ +25°C			100 100 400			100 100 400			100 150 400			100 150 400	$\mu\text{V/mA}$
Quiescent Current	2	3		2	3		2	3		2	3		mA
Power Dissipation	30			30			30			30			mW
Output Noise 0.1Hz to 10Hz Spectral Density, 100Hz	4 100			4 100			4 100			4 100			$\mu\text{V p-p}$ nV/ $\sqrt{\text{Hz}}$
Long-Term Stability	15			15			15			15			ppm/1000Hr
Short-Circuit Current-to-Ground	30	50		30	50		30	50		30	50		mA
Turn-On Settling Time to 0.01% FS	60			60			60			60			μs
Temperature Voltage Output	630			630			630			630			mV
Temperature Voltage Output Temperature Coefficient	2.1			2.1			2.1			2.1			mV/°C
Temperature Range Specified Performance	0		+70	0		+70	-55		+125	-55		+125	°C

NOTE

Specifications subject to change without notice.

Specifications in boldface are tested on all production units at final electrical test. Results from those tests are used to calculate outgoing quality levels. All min and max specifications are guaranteed, although only those shown in boldface are tested on all production units.

ORDERING GUIDE

Model	Initial Error mV	Temp. Coefficient ppm/°C	Temp. Range °C	Package Option*
ADREF01HQ/ADREF02HQ	50/25	25	0 to +70	Cerdip (Q-8)
ADREF01EQ/ADREF02EQ	30/15	8.5	0 to +70	Cerdip (Q-8)
ADREF01Q/ADREF02Q	50/25	25	-55 to +125	Cerdip (Q-8)
ADREF01AQ/ADREF02AQ	30/15	8.5	-55 to +125	Cerdip (Q-8)

*See Section 14 for package outline information.

THEORY OF OPERATION

The ADREF01 and ADREF02 consist of a proprietary buried Zener diode reference, an output buffer amplifier, and several high stability thin-film resistors. This design provides an accurate 10V reference with initial offset of 30mV or less, or an accurate 5V reference with initial offset of 15mV or less, and a temperature coefficient of 8.5ppm/°C (A and E grades).

LOAD REGULATION

The ADREF01 and ADREF02 have excellent load regulation characteristics. Figure 1 shows that varying the load several mA changes the output by only a few μV. The ADREF02 has somewhat better load regulation performance sourcing current than sinking current.

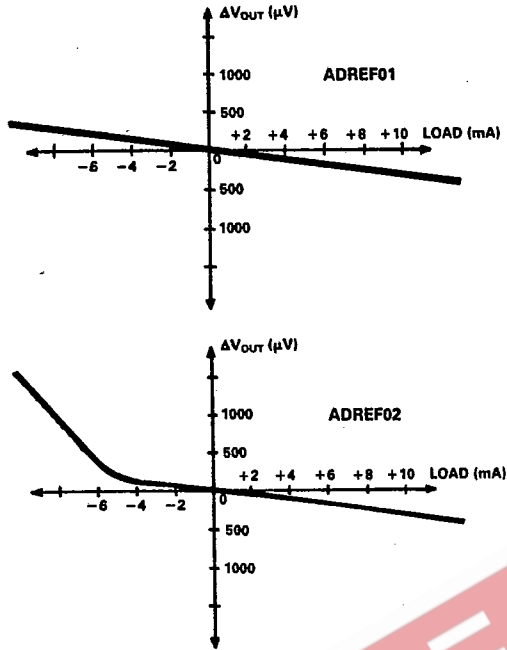

Figure 1. Typical Load Regulation Characteristics

TEMPERATURE PERFORMANCE

The ADREF01 and ADREF02 are designed for reference applications where good temperature performance is needed. Temperature testing ensures that the device's high level of performance is maintained over the operating temperature range.

Some confusion exists in the area of defining and specifying reference voltage error over temperature. Historically, references have been characterized using a maximum deviation per degree Centigrade; i.e., ppm/°C. However, because of nonlinearities in temperature characteristics which originated in standard Zener references (such as "S" type characteristics), most manufacturers have begun to use a maximum limit error band approach to specify devices. This technique involves the measurement of the output at three or more different temperatures to specify an output voltage error band.

Figure 2 shows the typical output voltage drift for the ADREF01E and ADREF02E and illustrates the test methodology. The box in Figure 2 is bounded on the sides by the operating temperature extremes, and on the top and the bottom by the maximum and minimum output voltages measured over the operating temperature range. The slope of the diagonal drawn from the lower left to the upper right corner of the box determines the performance grade of the device.

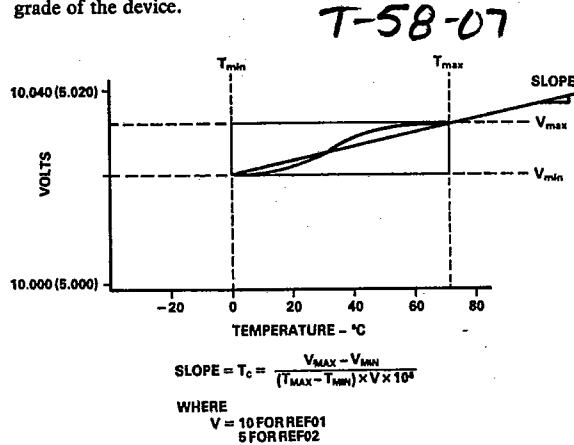

Figure 2. Typical ADREF01E/ADREF02E Temperature Drift

Each E and H grade unit is tested at 0, +25°C and +70°C. Each ADREF01/ADREF02 & A grade unit is tested at -55°C, +25°C and +125°C. This approach ensures that the variations of output voltage that occur as the temperature changes within the specified range will be contained within a box whose diagonal has a slope equal to the maximum specified drift. The position of the box on the vertical scale will change from device to device as initial error and the shape of the curve vary. The maximum height of the box for the appropriate temperature range and device grade is shown in Figure 3. Duplication of these results requires a combination of high accuracy and stable temperature control in a test system. Evaluation of the ADREF01 or ADREF02 will produce a curve similar to that in Figure 3, but output readings may vary depending on the test methods and equipment utilized.

DEVICE GRADE	MAXIMUM OUTPUT CHANGE (mV)	
	0 TO +70°C	-55°C TO +125°C
ADREF01H/02H	67.5/8.75	
ADREF01E/02E	36/2.98	
ADREF01/02		95/22.50
ADREF01A/02A		45.3/7.65

Figure 3. Maximum Output Change in mV

ADREF01/ADREF02

APPLYING THE ADREF01 AND ADREF02

The ADREF01 is simple to use in virtually all reference applications. When power is applied to Pin 2 and Pin 4 is grounded, Pin 6 provides a 10V output. No external components are required; the degree of desired absolute accuracy is achieved simply by selecting the required device grade. The ADREF01 requires less than 4mA quiescent current from an operating supply of +15V. The ADREF02 requires less than 3mA quiescent current from an operating supply of +12V or +15V.

An external fine trim may be desired to set the output level to exactly 10.000V or 5.000V when using ADREF02 (calibrated to a main system reference). System calibration may also require a reference voltage that is slightly different from 10.000V, for example, 10.24V for binary applications in the REF01 or 5.12V in the REF02. In either case, the optional trim circuit shown in Figure 4 can offset the output by as much as 300mV, if desired, with minimal effect on other device characteristics.

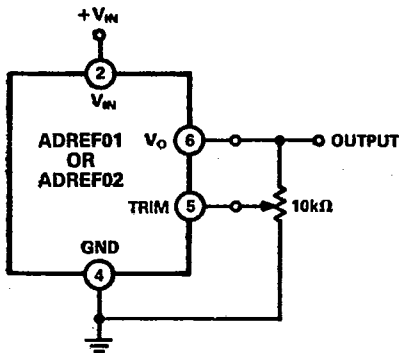

Figure 4. Optional Fine Trim Configuration

NEGATIVE REFERENCE VOLTAGE FROM AN ADREF01

The ADREF01 can be used to provide a -10.000V output as shown in Figure 5. The V_{IN} pin is tied to at least a +3.5V supply, the output pin is grounded, and the ADREF01 ground pin is connected through a resistor, R_S , to a -15V supply. The -10V output is now taken from the ground pin (Pin 4) instead of V_{OUT} . It is essential to arrange the output load and the supply resistor R_S so that the net current through the ADREF01 is between 2.5mA and 10mA. The temperature characteristics and long-term stability of the device will be essentially the same as that of a unit used in the standard +10V output configuration.

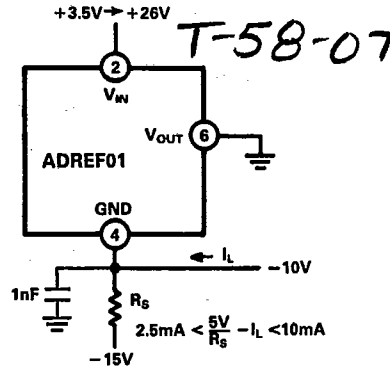

Figure 5. Negative 10V Reference

NEGATIVE REFERENCE VOLTAGE FROM AN ADREF02

The ADREF02 can be used to provide a -5.000V output as shown in Figure 6. The V_{IN} pin is tied to at least a +6V supply, the output pin is grounded, and the ADREF02 ground pin is connected through a 4kΩ resistor to a -15V supply. The -5V output is now taken from the ground pin (Pin 4) instead of V_{OUT} . It is essential to arrange the output load and the supply resistor R_S so that the net current through the ADREF02 is less than 5mA. The temperature characteristics and long-term stability of the device will be essentially the same as that of a unit used in the standard +5V output configuration.

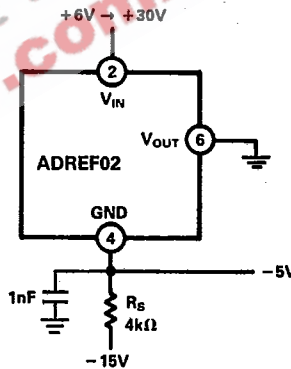

Figure 6. Negative 5V Reference

5V OR 10V REFERENCE WITH MULTIPLYING CMOS D/A OR A/D CONVERTERS

The ADREF02 is ideal for applications with 10- and 12-bit multiplying CMOS D/A converters. In the standard hook-up, as shown in Figure 7, the ADREF02 is paired with the AD7533 10-bit multiplying DAC and the AD711 high-speed BiFET op amp. The amplifier/DAC configuration produces a unipolar 0 to -5V output range. Bipolar output applications and other operating details can be found on the AD7533 data sheet. The ADREF01 can also be used in this configuration to produce a unipolar 0 to -10V output range.

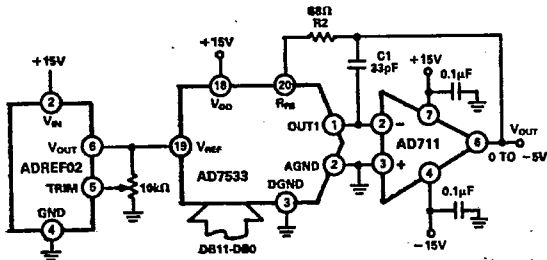

Figure 7. Low-Cost 10-Bit CMOS DAC Application

CURRENT SOURCE

The design of the ADREF01 allows it to be easily configured as a current source. The voltage drop from Pin 2 to Pin 4 in Figure 8 must remain between 13.5V and 36V. There will be a constant 10V drop across R_C . By choosing control resistor R_C you can vary the load current from the quiescent current (2mA typically) to approximately 10mA.

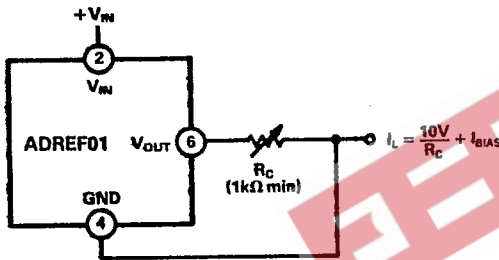

Figure 8. Current Source

In the case of the ADREF02, the voltage drop across Pin 2 to Pin 4 from Figure 8 must remain between 8V and 36V. There will be a constant 5V drop across R_C (500Ω minimum)

$$I_L = \frac{5V}{R_C} + I_Q$$

TEMPERATURE TRANSDUCER 7-58-07

The temperature out pin of the ADREF02 allows it to be used as a temperature transducer. The output of Pin 3 (TEMP) is a voltage that varies linearly with temperature. V_{TEMP} at 25°C is 630mV, and the temperature coefficient is 2.1mV/°C. In the configuration shown in Figure 9, V_{OUT} from Pin 6 of the ADREF02 provides a stable reference voltage for the AD OP-07 op amp. The temperature dependent voltage from the TEMP pin of the ADREF02 is amplified by the AD OP-07 to provide a wider full-scale range and more current sourcing capability.

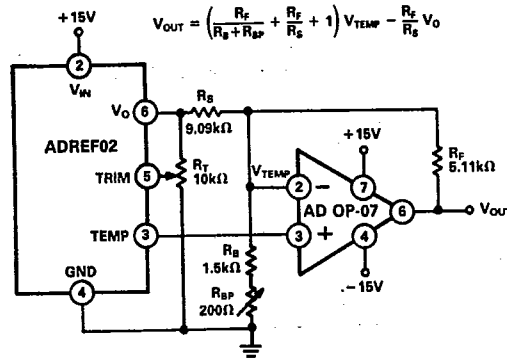

TEMPERATURE	V _{OUT}
-55°C	-0.55V
0°C	0V
+125°C	+1.25V

Figure 9. Temperature Transducer

The resistor values in Figure 9 produce an output (V_{OUT}) that varies 10mV/°C from -0.55V to +1.25V over the military temperature range. The potentiometer R_T controls the offset of the transfer function, and the potentiometer R_{BP} controls its slope. The equation in Figure 9 can be used to set resistor values for other output ranges.