

Am26LS29

Am26LS29

Quad Three-State Single Ended RS-423 Line Driver

DISTINCTIVE CHARACTERISTICS

- Four single ended line drivers in one package for maximum package density
- Output short-circuit protection
- Individual rise time control for each output
- High capacitive load drive capability
- Low ICC and IEE power consumption (26mW/driver typ.)
- Meets all requirements of RS-423
- Three-state outputs for bus oriented systems
- Outputs do not clamp line with power off or in hi-impedance state over entire transmission line voltage range of RS-423
- Low current PNP inputs compatible with TTL, MOS and CMOS
- Available in military and commercial temperature range
- Advanced low power Schottky processing

GENERAL DESCRIPTION

The Am26LS29 is a quad single ended line driver, designed for digital data transmission. The Am26LS29 meets all the requirements of EIA Standard RS-423 and Federal STD 1030. It features four buffered outputs with high source and sink current, and output short circuit protection.

A slew rate control pin allows the use of an external capacitor to control slew rate for suppression of near end cross talk to receivers in the cable.

The Am26LS29 has three-state outputs for bus oriented systems. The outputs in the hi-impedance state will not clamp the line over the transmission line voltage of RS-423. A typical full duplex system would use the Am26LS29 line driver and up to twelve Am26LS32 line receivers or an Am26LS32 line receiver and up to thirty-two Am26LS29 line drivers with only one enabled at a time and all others in the three-state mode.

The Am26LS29 is constructed using advanced low-power Schottky processing.

BLOCK DIAGRAM

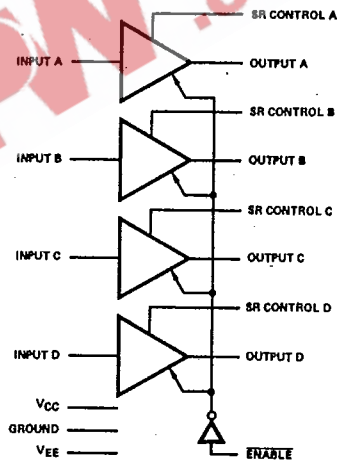

RELATED PRODUCTS

Part No.	Description
26LS30	Dual Differential RS-422 Party Line/Quad Single Ended RS-423 Line Driver
26LS32	Quad Differential Line Receiver
26LS33	Quad Differential Line Receiver

04599A

Am26LS29

**CONNECTION DIAGRAM
Top View**

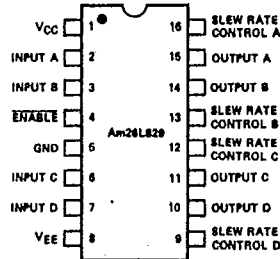

CD002060

Note: Pin 1 is marked for orientation

METALLIZATION AND PAD LAYOUT

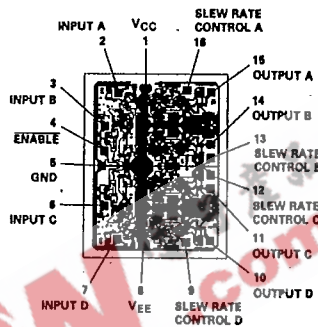

DIE SIZE 0.070" x 0.094"

ORDERING INFORMATION

AMD products are available in several packages and operating ranges. The order number is formed by a combination of the following: Device number, speed option (if applicable), package type, operating range and screening option (if desired).

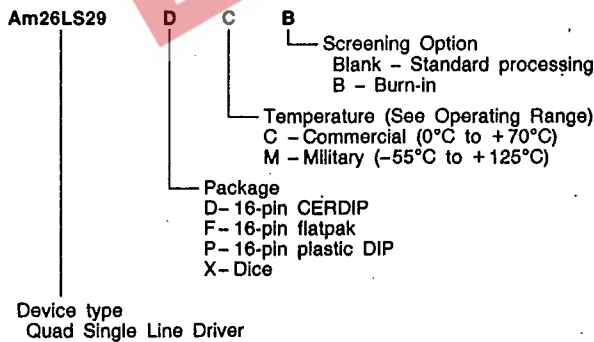

Valid Combinations	
Am26LS29	PC DC, DM FM XC, XM

Valid Combinations
Consult the AMD sales office in your area to determine if a device is currently available in the combination you wish.

10

Am26LS29

TYPICAL APPLICATION

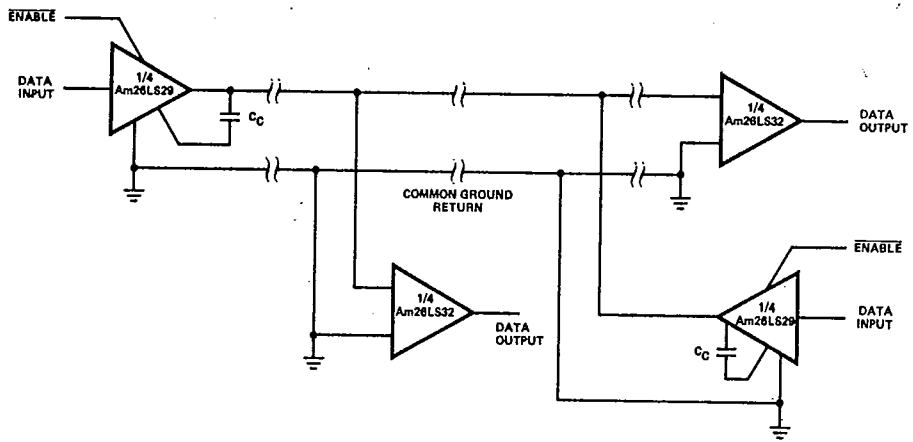

AF001260

EEPW 电子产品世界 .com.cn

Am26LS29

ABSOLUTE MAXIMUM RATINGS

Storage Temperature -65°C to +150°C
 Supply Voltage
 V+ 7.0V
 V- -7.0V
 Power Dissipation 600mW
 Input Voltage -0.5 to +15.0V
 Output Voltage (Power Off) ±15V
 Lead Soldering Temperature (10 seconds) 300°C

Stresses above those listed under ABSOLUTE MAXIMUM RATINGS may cause permanent device failure. Functionality at or above these limits is not implied. Exposure to absolute maximum ratings for extended periods may affect device reliability.

OPERATING RANGES

Commercial (C) Devices
 Temperature 0°C to +70°C
 Supply Voltage (V_{CC}) +4.75V to +5.25V
 (V_{EE}) -4.75V to -5.25V
 Military (M) Devices
 Temperature -55°C to +125°C
 Supply Voltage (V_{CC}) +4.5V to +5.5V
 (V_{EE}) -4.75 to -5.5V

Operating ranges define those limits over which the functionality of the device is guaranteed.

DC CHARACTERISTICS over operating range unless otherwise specified

Parameters	Description	Test Conditions	Min	Typ (Note 1)	Max	Units
V _O V _O	Output Voltage	R _L = ∞(Note 3) V _{IN} = 2.4V V _{IN} = 0.4V	4.0 -4.0	4.4 -4.4	6.0 -6.0	Volts
V _T V _T	Output Voltage	R _L = 450Ω V _{IN} = 2.4V V _{IN} = 0.4V	3.6 -3.6	4.1 -4.1		Volts
V _{T+} - V _{T-}	Output Unbalance	V _{CC} = V _{EE} , R _L = 450Ω		0.02	0.4	Volts
I _{X+} I _{X-}	Output Leakage Power Off	V _{CC} = V _{EE} = 0V V _O = 10V V _O = -10V		2.0 -2.0	100 -100	μA
I _{S+} I _{S-}	Output Short Circuit Current	V _O = 0V V _{IN} = 2.4V V _{IN} = 0.4V		-70 60	-150 150	mA
I _{SLEW}	Slew Control Current	V _{SLEW} = V _{EE} + 0.9V		±110		μA
I _{CC}	Positive Supply Current	V _{IN} = 0.4V, R _L = ∞		18	30	mA
I _{EE}	Negative Supply Current	V _{IN} = 0.4V, R _L = ∞		-10	-22	mA
I _O	Off State (High Impedance) Output Current	V _{CC} = MAX V _O = 10V V _O = -10V		2.0 -2.0	100 -100	μA
V _{IH}	High Level Input Voltage		2.0			Volts
V _{IL}	Low Level Input Voltage				0.8	Volts
I _{IH}	High Level Input Current	V _{IN} = 2.4V V _{IN} < 15V		1.0 10	40 100	μA
I _{IL}	Low Level Input Current	V _{IN} = 0.4V		-30	-200	μA
V _I	Input Clamp Voltage	I _{IN} = -12mA			-1.5	Volts

- Notes: 1. Typical limits are at V_{CC} = 5.0V, V_{EE} = -5.0V, 25°C ambient and maximum loading.
 2. Symbols and definitions correspond to EIA RS-423 where applicable.
 3. Output voltage is +3.9V minimum and -3.9V minimum at -55°C.

TYPICAL PERFORMANCE CURVES

Slew Rate (Rise or Fall Time) Versus External Capacitor

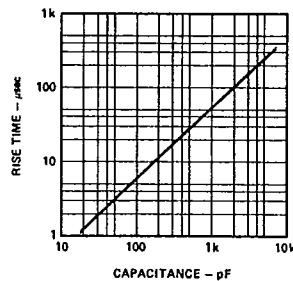

OP001290

10

Am26LS29

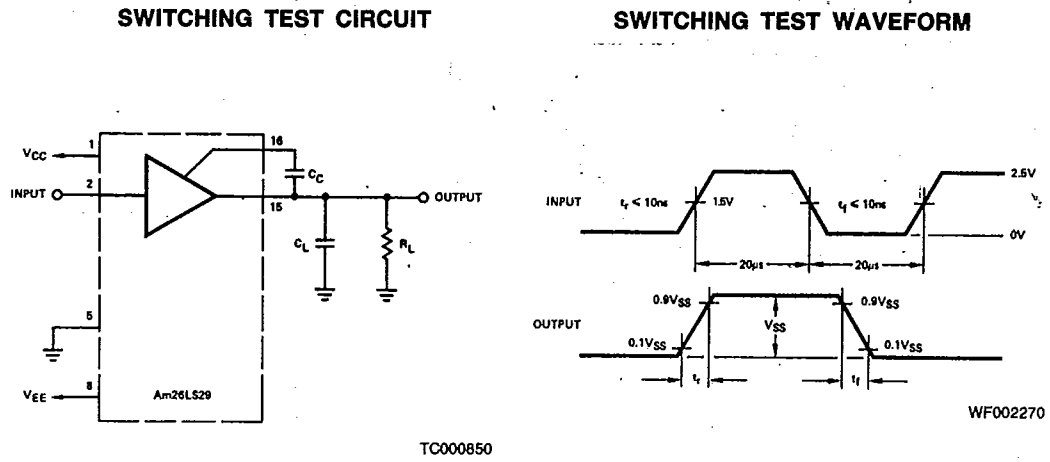

Figure 1. Rise Time Control.

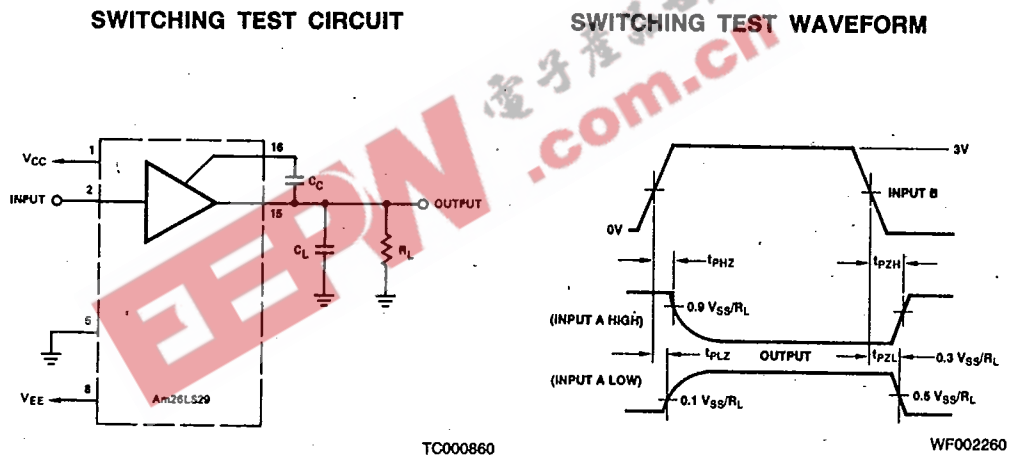
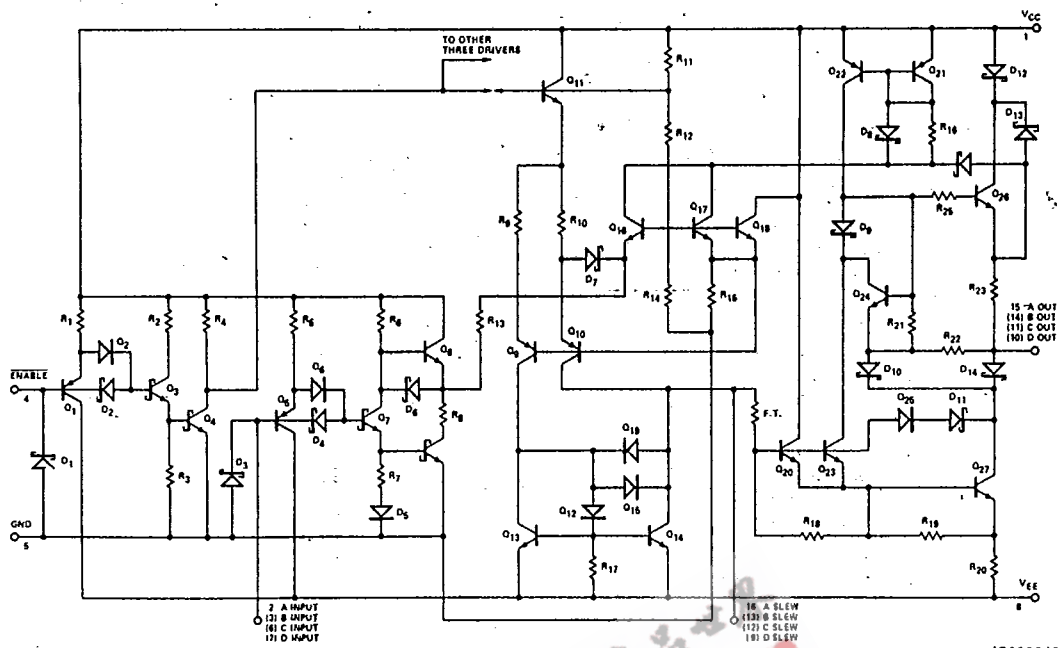

Figure 2. Three State Delays

SWITCHING CHARACTERISTICS (TA = +25°C, VCC = 5.0V, VEE = -5.0V)

Parameters	Description	Test Conditions	Min	Typ	Max	Units	
tr	Rise Time	RL = 450 Ω, CL = 500 pF, Fig. 1	CC = 50 pF		3.0		μs
			CC = 0 pF		120	300	ns
tf	Fall Time	RL = 450 Ω, CL = 500 pF, Fig. 1	CC = 50 pF		3.0		μs
			CC = 0 pF		120	300	ns
Src	Slow Rate Coefficient	RL = 450 Ω, CL = 500 pF, Fig. 1		.06		μs/pF	
tLZ	Output Enable to Output	RL = 450 Ω, CL = 500 pF, CC = 0 pF, Fig. 2		180	300	ns	
tHZ				250	350		
tZL				250	350		
tZH				180	300		

Am26LS29EQUIVALENT CIRCUIT



Am26LS29

EPW.com.cn 电子產品

IC000240